



(12) **EUROPEAN PATENT APPLICATION**

(43) Date of publication:
31.03.2010 Bulletin 2010/13

(51) Int Cl.:
F24F 13/00^(2006.01)

(21) Application number: **09012331.6**

(22) Date of filing: **29.09.2009**

(84) Designated Contracting States:
AT BE BG CH CY CZ DE DK EE ES FI FR GB GR HR HU IE IS IT LI LT LU LV MC MK MT NL NO PL PT RO SE SI SK SM TR
Designated Extension States:
AL BA RS

- **Kato, Fumihito**
Shizuoka-shi,
Shizuoka, (JP)
- **Sasaki, Hajime**
Shizuoka-shi,
Shizuoka, (JP)
- **Seki, Kenji**
Shizuoka-shi,
Shizuoka, (JP)
- **Muramatsu, Naoki**
Shizuoka-shi,
Shizuoka, (JP)
- **Maeda, Kensaku**
Shizuoka-shi,
Shizuoka, (JP)

(30) Priority: **30.09.2008 JP 2008253824**
30.09.2008 JP 2008253832

(71) Applicant: **Hitachi Appliances, Inc.**
Minato-ku
Tokyo (JP)

(72) Inventors:
• **Yamada, Emi**
Shizuoka-shi,
Shizuoka, (JP)
• **Nakayama, Satoshi**
Shizuoka-shi,
Shizuoka, (JP)

(74) Representative: **Beetz & Partner**
Patentanwälte
Steinsdorfstrasse 10
80538 München (DE)

(54) **Air conditioner**

(57) In an air conditioner, for preventing blown air from directly rushing to a position below the air conditioner and suppressing a ceiling surface (32) from being smudged due to a Coanda effect, in order to provide a simple structure of a wind direction control louver (42) provided in a air outlet (41), there is provided an air conditioner including: an air conditioner body (1); a panel (6) which is provided in the body; an air inlet (3) which is provided at about a center of the panel; an air outlet (4) which is provided in the periphery of the air inlet and blows air into a room; and a wind direction control louver (2) which is provided in the air outlet, wherein one end of the louver (2) is provided in the panel (6) on the side of the air inlet so as to be rotatable through a shaft (5), and the other end thereof is formed as an opening edge, and wherein the opening edge exists on more outer side than a portion where blown air descending from the outermost side of the air outlet (4) contacts with the louver (2) when the louver (2) is opened at a maximum louver opening degree θ_{max} .

FIG. 1

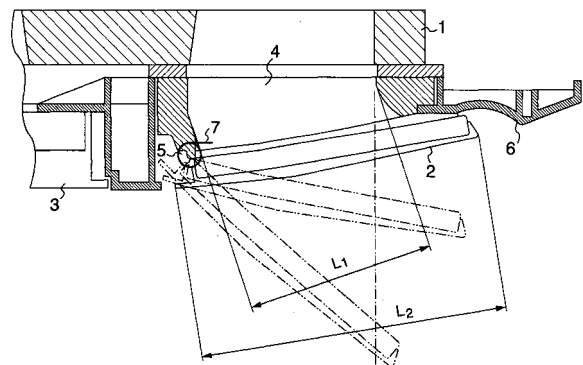

Description

Field of The Invention

[0001] The present invention relates to an air conditioner in which an indoor unit is disposed in a ceiling, and particularly, to a structure of a wind direction control louver.

Description of Related Art

[0002] In general, in an in-the-ceiling type air conditioner, an air conditioner body is accommodated inside a ceiling, and a panel portion, which is provided with an air inlet for sucking air from the room and an air outlet for blowing a cold or warm wind set to an adjusted temperature, is installed in a ceiling surface so as to be exposed thereto. The air conditioner body provided inside the ceiling accommodates components such as a box having control electric components therein, a heat exchanger for adjusting an air temperature, a fan, and a driving motor for circulating the air in the room. Meanwhile, the panel portion accommodates a wind direction control plate for adjusting a blowing angle of the cold or warm wind set to an adjusted temperature and a driving device thereof or the like.

[0003] As a known technology in a structure of a wind direction control plate, for example, JP-A-2007-322114 discloses a structure in which one edge of the wind direction control plate in the longitudinal direction (a direction of a shaft of the wind direction control plate) is formed in a linear shape and the other edge thereof is formed in a shape in which the curve degree of the center portion is lower than those of both side portions. According to this structure, the wind directions of the blown air-conditioning air are the same and the wind speed distribution is substantially uniform. Accordingly, it is possible to prevent a Coanda effect in which the stream direction changes along an object disposed in a stream of the air. As a result, it is possible to prevent the air stream from directly blowing to the ceiling surface and to suppress the ceiling surface from being smudged.

[0004] In addition, as a known technology for preventing the air stream sent out from the air conditioner from directly contacting with a human body while suppressing the smudging of the ceiling surface, for example, JP-A-2006-336961 discloses a technology based on a structure related to a wind direction control plate and an indoor air outlet. According to this technology, there are provided a wind direction deflection plate which deflects the blown air stream in the vertical direction, a first air outlet of a panel, and a second air outlet which blows a wind along a surface of the ceiling. By the operation of closing the wind direction deflection plate, the wind is blown from the second air outlet along the surface of the ceiling.

[0005] However, in the technology disclosed in JP-A-2007-322114, a length of the air-conditioning air in the stream direction perpendicular to the longitudinal direc-

tion of the wind direction control plate is not sufficient, and an air passageway is formed so as to blow the air-conditioning air from the inside and the outside of the wind direction control plate. In this technology, a countermeasure for preventing the cold or warm wind from directly contacting with a human body located below the air conditioner is not sufficiently considered.

[0006] Further, in the technology disclosed in JP-A-2006-336961, upon selecting an air stream along the ceiling surface when the temperature and humidity in the air-conditioning space are stable and the cooling load is reduced, the outer peripheral portion of the panel is moved in the vertical direction. At this time, since it is necessary to change the direction of the air outlet for moving down the outer peripheral portion of the panel, the air conditioner is required to have a complicated structure and has to perform a complicated operation. In this technology, a countermeasure for performing the operation with a simpler structure is not sufficiently considered.

Brief Summary of The Invention

[0007] An object of the invention is to provide an air conditioner capable of preventing blown air from directly blowing to a position below an air conditioner and suppressing a ceiling surface from being smudged due to a Coanda effect by a simple structure of a wind direction control louver provided in an air outlet.

[0008] In order to achieve the above-described object, the invention adopts the following configuration.

[0009] According to an aspect of the invention, there is provided an in-the-ceiling type air conditioner including: an air conditioner body which is disposed in a ceiling; a panel which is provided on a bottom surface of the body; an air inlet which is provided at about the center of the panel and sucks air from a room into the body; an air outlet which is provided in the periphery of the air inlet and blows air into a room; and, a wind direction control louver which is provided in the air outlet, wherein one end of the louver is provided in the panel on a side of the air inlet so as to be rotatable through a shaft, and the other end thereof is formed as an opening edge, and wherein the opening edge exists on the far outside of a portion where blown air descending from the outermost side of the air outlet contacts with the louver when the louver is opened at a maximum louver opening degree θ_{max} .

[0010] According to another aspect of the invention, there is provided an in-the-ceiling type air conditioner including: an air conditioner body which is disposed in a ceiling; a panel which is provided on a bottom surface of the body; an air inlet which is provided at about the center of the panel and sucks air from a room into the body; an air outlet which is provided in the periphery of the air inlet and blows air into a room; and, a wind direction control louver which is provided in the air outlet, wherein one end of the louver is provided in the panel on the side of the air inlet so as to be rotatable through a shaft, and the

other end thereof is formed as an opening edge, and wherein a relationship between a length L1 of the air outlet in a direction perpendicular to the shaft and a length L2 of the louver in a direction perpendicular to the shaft is $L2 > L1$, and a ratio $L2/L1$ is 1.4 to 1.8.

[0011] According to still another aspect of the invention, there is provided an in-the-ceiling type air conditioner including: an air conditioner body which is disposed in a ceiling; a panel which is provided on a bottom surface of the body; an air inlet which is provided at about the center of the panel and sucks air from a room into the body; an air outlet which is provided in the periphery of the air inlet and blows air into a room; and, a louver for wind direction control which is provided in the air outlet, wherein the louver is formed in a cantilever structure in which one end of the louver is provided in the panel on the side of the air inlet so as to be rotatable through a shaft and the other end thereof is formed as an opening end, and wherein the louver has a slope shape, in which a protruding portion is provided at about the center in a transverse direction which is a direction of the shaft and is lowered in the transverse direction, and distributes a blow air stream descending via the air outlet in the transverse direction.

[0012] In the in-the-ceiling type air conditioner, the louver may include a louver body and a thermal insulator which is fitted onto the louver body; and the louver body may be provided with a rib having a height forming the protruding portion at about the center in the transverse direction of the louver body and with ribs intermittently formed so as to be lowered toward the ends of the louver body in the transverse direction. In the in-the-ceiling type air conditioner, the left and right ends of the louver body may be respectively provided with stoppers to which the thermal insulator is fitted, and the thermal insulator may be detachably fitted onto the louver body via a gap between the louver body and the stoppers.

[0013] In the in-the-ceiling type air conditioner, one end of the shaft provided in the one end of the louver may be connected to a motor, and the other end of the shaft may be provided with a spring which urges the louver in a direction in which the louver is closed. The louver may be formed in a slope shape, in which a protruding portion is formed at about the center in the transverse direction which is the axial direction of the shaft, and which is lowered in the transverse direction, so as to distribute a blown air stream descending via the air outlet in the transverse direction.

[0014] According to the invention, one end of the louver provided in the air outlet is provided in the panel on the side of the air inlet so as to be rotatable through a shaft, and the other end thereof is formed as an opening end. In addition, the length L2 of the louver in the width direction (a direction perpendicular to the shaft of the louver) is specified. Accordingly, it is possible to suppress the air-conditioning air from being blown to a position below the air conditioner.

[0015] In addition, since it is possible to ensure a dis-

tance in which the height position of the opening end of the louver is distant from the ceiling surface at a minimum blowing angle of the louver by increasing the length of the louver in the width direction, it is possible to suppress the ceiling surface from being smudged due to the Coanda effect with a simple structure.

Brief Description of Several Views of Drawing

10 **[0016]**

Fig. 1 is a diagram showing a configuration of a louver for wind direction control at an air outlet of an air conditioner according to the embodiment of the invention.

15

Fig. 2 is a diagram showing a configuration of the louver for wind direction control having a thermal insulator according to the embodiment.

20

Fig. 3 is a diagram showing a general configuration of an in-the-ceiling type air conditioner according to the embodiment.

25

Fig. 4 is a diagram showing a structure of a louver body for wind direction control according to the embodiment.

Detailed Description of The Invention

30

[0017] An in-the-ceiling type air conditioner according to the embodiment of the invention will be described below in detail with reference to Figs. 1 to 4. Fig. 1 is a diagram showing a configuration of a louver for wind direction control of an air outlet of an air conditioner according to the embodiment of the invention. Fig. 2 is a diagram showing a configuration of the louver for wind direction control having a thermal insulator according to the embodiment. Fig. 3 is a diagram showing a general configuration of an in-the-ceiling type air conditioner according to the embodiment. Fig. 4 is a diagram showing a structure of a louver body for wind direction control according to the embodiment.

35

40

[0018] First, the general configuration of the air conditioner according to the embodiment of the invention will be schematically described with reference to Fig. 3. The reference numeral 31 denotes a beam of a building. The reference numeral 32 denotes a ceiling board. The reference numeral 33 denotes a body of the air conditioner which is provided between the beam 31 and the ceiling board 32. The reference numeral 34 denotes an anchor bolt fixed to the beam. The reference numeral 35 denotes a panel which shields an opening of the ceiling board 32 and a lower opening end of the body 33 of the air conditioner.

45

50

[0019] An air inlet 37 having a filter 36 is provided at the center of the panel 35. An air outlet 41 having louvers for wind direction control (wind direction plates) 42 arranged in four directions in the periphery of the air inlet is provided. A fan motor 38, a fan 39, and a heat exchanger 40 are installed in the passageway connecting the air

55

inlet 37 to the air outlet 41. The air sucked from the room to the fan 39 via the air inlet 37 is subjected to a heat exchange operation using the heat exchanger 40, and is sent from the air outlet 41 into a room via the louvers for wind direction control (wind direction plates) 42.

[0020] In Figs. 1 and 2, the air conditioner according to the embodiment includes an air conditioner body 1 (hereinafter, referred to as a body) which is embedded in a ceiling; a panel 6 which is provided on a bottom surface of the body 1; an air inlet 3 which is provided at about the center of the panel 6 so as to suck the air from the room into the body 1; air outlets 4 which are provided in four peripheral edges of the air inlet 3 so as to blow air to a room; louvers 2 for wind direction control (hereinafter, referred to as louvers) which are provided in the air outlets; a shaft 5 which is provided in one rotary end of each louver 2; a spring 7 which urges the shaft in a direction in which the louver is closed; and a motor 10 which drives the shaft 5.

[0021] Here, in the air outlets 4 provided on the outside of the four peripheral edges of the air inlet 3, the air outlets are not provided at the corners where the four edges intersect each other. Accordingly, in the case of the known technology, the cold or warm wind does not reach four positions of the room facing the four corners. On the contrary, in the embodiment of the invention, the cold or warm wind can reach the four positions of the room facing the four corners by means of the structure of the louver shown in Fig. 2, and the detail thereof will be described later.

[0022] The louver 2 is provided to be rotatable by the means of the shaft 5 in a support portion of the panel 6 provided on the inside of the air outlet 4 (on the side close to the air inlet 3) so as to prevent the cold or warm wind generated by the body of the air conditioner from passing into the room from the inside of the shaft 5 (the side close to the air inlet 3), that is, the rear surface side of the louver. In addition, the general air conditioner shown in Fig. 3 includes a space which is provided on the inside (the rear surface side) and the outside (the side close to the outer periphery of the panel 35, that is, the pressure surface side of the louver) of the louver 42 so as to allow the cold or warm wind to pass therethrough. The louver 2 according to the embodiment is formed in a so-called cantilever structure through the shaft 5 at the support portion of the panel 6. Due to this structure, in the louver 2, the louver length (in the example shown in Fig. 1, a length from the left end of the louver 2 to the right end thereof or a length of the louver 2 in a direction perpendicular to the shaft 5) from the inside of the air outlet 4 to the outside thereof is formed to be larger than that shown in Fig. 3.

[0023] In addition, the another reason why the length of the louver 2 is formed to be long is to blow the cold or warm wind into the room at a predetermined flow rate at which flow rate the cold or warm wind descending along the body 1 collides with the louver 2 and further flows along the louver shape when an opening degree of the

louver 2 is maximum (an angle of 35° to 55° relative to the horizontal position of the ceiling board and desirably an angle of 40° to 50° relative thereto) (in the example shown in Fig. 1, the lowermost two-dot dashed line), and to prevent the cold or warm wind from flowing in a direction right below the air outlet 4. When the stream of the cold or warm wind flowing in a direction right below the air outlet 4 is directly guided to the air inlet 3 so as to enter therein, a short circuit is formed. For this reason, in order to prevent the short circuit, the length of the louver 2 is formed to be long. In addition, when the blown air flows in a direction right below the air outlet 4, the cold or warm wind directly blows to a human body located at the position where the blown air flows, and hence the cold or warm wind has a bad influence on the human body. For this reason, in order to prevent the bad influence, the length of the louver 2 is formed to be long.

[0024] Referring to Fig. 1, a length L1 is a length of the air outlet 4 in a direction perpendicular to the shaft 5, and a length L2 is a length of the louver 2 in the direction perpendicular to the shaft 5. The louver 2 rotates about the shaft 5 serving as a support point, and the other end thereof is adapted to be opened to a position of the maximum louver angle θ_{\max} (for example, the louver opening degree at the lowermost level shown in Fig. 1) from a position where the air outlet is closed (a position horizontal to the ceiling surface). That is, during the operation of the air conditioner, the other end thereof is adapted to be rotatable between the minimum louver opening degree θ_{\min} (for example, the louver opening degree at the middle level shown in Fig. 1) and the maximum louver opening degree θ_{\max} , thereby controlling the opening degree. The minimum louver opening degree θ_{\min} is formed to be equal to an opening degree capable of suppressing the ceiling surface from being smudged due to the Coanda effect caused by the blown air even when the louver opening degree is the minimum louver opening degree θ_{\min} . In detail, in the louver opening degree, the θ_{\min} is set to the range of 15° to 35° , and is desirably set to the range of 20° to 30° . The θ_{\max} is set to the range of 30° to 55° , and is desirably set to the range of 40° to 50° .

[0025] One of the characteristics of the embodiment is the louver length in which the blown air descending from the outermost side of the air outlet of the body 1 collides with the louver 2 having the maximum louver opening degree θ_{\max} and further flows along the surface of the louver 2. That is, as shown in Fig. 1, the length is set so that the perpendicular line depicted by the one-dot chain line from the outermost side of the air outlet of the body 1 intersects the inside of the opening edge (front end) of the louver 2 at the maximum louver opening degree θ_{\max} depicted by the two-dot chain line. The extending degree of the length of the louver 2 from the intersection point is set to a dimension in which the short circuit to the air inlet 3 is not formed and is desirably set to a length in which the louver front end exists on the side sufficiently outer than the outermost side of the air outlet

(for example, the outside of the outer surface of the body 1) at the minimum louver opening degree θ_{\min} . Likewise, when the louver length is set to be large, it is possible to uniformly distribute the air blown from the air outlet to a far position along the louver, and thus to suppress the generation of the non-uniform temperature. Particularly, since it is possible to blow the air blown from the air outlet to a far position in a substantially horizontal direction along the louver at the minimum louver opening degree θ_{\min} , it is possible to reliably prevent the cold or warm wind from directly rushing to the human body located below the air outlet, and thus to prevent the uncomfortable feeling caused by the exposure to the wind.

[0026] In addition, it is desirable that the minimum louver opening degree θ_{\min} is set to an angle capable of suppressing the ceiling surface from being smudged due to the Coanda effect. Here, the smudging of the ceiling surface due to the Coanda effect indicates a phenomenon in which the air flowing out along the surface of the louver 2 passes through a position close to the ceiling, and a negative pressure is generated between the passing air and the ceiling so that a smudging component in the air is adhered to the ceiling. Since the louver is formed to be longer than the intersection point where the louver intersects the perpendicular line depicted by the one-dot dashed line shown in Fig. 1 even in the case of the maximum louver opening degree θ_{\max} , a gap between the ceiling surface and the opening edge of the louver 2 at the θ_{\min} becomes large, thereby further exhibiting the smudging suppression effect. In addition, the uppermost level of the louver opening degree shown in Fig. 1 corresponds to the case where the louver 2 is closed when the air conditioner is in a stop state. A concave portion is formed in a portion of the panel located at about the center between the outermost portion of the panel 6 and the outermost side of the air outlet 4. By allowing the front end of the louver to be located at the concave portion of the panel 6 when the louver 2 is in a closed state, it is possible to prevent the louver from protruding from the panel. That is, when the louver is in a closed state, the rear surface of the louver is substantially located at the same level as that of the surface of the panel, and hence the entire shape of the panel 6 smoothly changes. Accordingly, it is possible to improve the design of the panel.

[0027] In other words, when the angle of the louver 2 is set to a predetermined angle relative to the horizontal position of the ceiling surface, if the louver length in a direction (width direction) perpendicular to the shaft is short as in the known example (as compared with the long louver according to the embodiment), the possibility of the short circuit effect in which the blown air is guided to the air inlet 3 increases. If the rotary angle is set to be small in order to prevent the short circuit effect, the Coanda effect may be easily generated. On the contrary, in the embodiment, since the louver length is set so that the short circuit effect is not generated at the louver opening degree (θ_{\max}) of the lowermost level shown in Fig. 1, a distance between the ceiling surface and the louver

opening edge at the louver opening degree (θ_{\min}) of the middle level shown in Fig. 1 becomes large, and hence the Coanda effect is hardly generated.

[0028] In addition, as shown in Fig. 1, from the viewpoint of the length L1 of the air outlet 4 (the length of the air outlet 4 in the direction perpendicular to the shaft 5) and the length L2 of the louver 2 (the length of the louver 2 in the direction perpendicular to the shaft 5), as the detailed example of the dimensions (a detailed structure example in which the above-described short circuit effect is not generated and the Coanda effect is hardly generated), the length L1 is 66.5 mm and the length L2 is 106 mm, where the ratio L2/L1 is 1.59. From the results of various experiments, it is proved that the ratio L2/L1 of 1.6 is optimal and the ratio L2/L1 of 1.4 to 1.8 is satisfactory.

[0029] In the louver 2, when the motor shaft is rotated by the control input signal applied to the motor 10, the shaft 5 is rotated by the rotation of the motor shaft, thereby adjusting the opening degree of the louver 2. The reason why the rotary support point of the louver 2 is located at the innermost side of the air outlet 4 and the cold or warm wind does not pass through a position on the inside of the rotary support point (on the side of the louver rear surface) is to prevent the cold or warm wind from rushing to the lower side of the air conditioner. It is not desirable that the strong cold or warm wind directly rushes from the air conditioner to a person located on the lower side of the air conditioner, but it is desirable that the cold or warm wind is indirectly sent to the person from the periphery thereof. In addition, when the cold or warm wind is blown to the lower side of the air conditioner, the blown cold or warm wind is directly guided to the air inlet 3, which deteriorates the air-conditioning effect. The invention prevents the deterioration in the air-conditioning effect.

[0030] In Figs. 2 and 4, the louver 2 includes a louver body 12 and a thermal insulator 8 which is separably mounted to the louver body 12. As shown in Fig. 4, in the louver body 12, one end thereof is set to the shaft 5, and the other end thereof (in the example shown in Fig. 4, the lower end) is set to an opening end. The cold or warm wind is guided from the opening end so as to enter the room. In addition, the thermal insulator 8 is formed to be spongiose, where the thermal insulation effect is exhibited by bubbles provided inside the sponge and a resin foam is an example of the material thereof, that is, the thermal insulator 8 may be formed of a material which is more or less deformable. The thermal insulator 8 formed in a flat shape (rectangular cube shape) is provided in the louver body 12 indicated in Fig. 4 so as to be fitted to a gap between the louver body 12 and stoppers 9 (left and right ends), and hence the thermal insulator 8 is incorporated into the louver body 12.

[0031] Since the louver 2 according to the embodiment is formed in a cantilever structure which is rotatable about the shaft 5 and the blown air does not pass through a position on the inside of the shaft (the side of the louver

rear surface), when the cold wind used for a cooling operation contacts with the louver rear surface (the side of the louver close to the air conditioner body), droplets of condensation may be formed on the louver surface (the side of the louver close to the room). In order to prevent the dew drops, the thermal insulator 8 is provided on the front surface side (pressure surface side) of the louver 2.

[0032] Fig. 2 shows an incorporated structure in which the thermal insulator 8 is mounted to the louver body 12. Since the left and right ends of the louver body 12 are provided with the stoppers 9 to which the thermal insulator 8 is fitted, it is possible to easily to mount the thermal insulator 8 to the louver body 12 by fitting it even if not using a bonding agent or a gluing agent, and thus to facilitate the exchange operation of the thermal insulator 8.

[0033] In Fig. 2 showing the entire structure of the louver, the stream of the cold or warm wind is depicted by the arrow. The cold or warm wind descending from the air conditioner body comes into contact with the louver 2 and the stream thereof changes. In the known louver, the cold or warm wind flows in parallel to the length direction of the louver. However, in the embodiment according to the invention, the stream of the cold or warm wind includes a cold or warm wind stream component (a stream component in the length direction of the louver 2) parallel to the length direction of the louver 2, and a cold or warm wind stream component (a stream component in the width direction of the louver 2) perpendicular to the length direction and toward the motor 10 or the spring 11. The latter cold or warm wind stream component is used as a stream in which the cold or warm wind reaches the positions of the room facing the corners of the air outlets 4 provided on the four peripheral edges of the air inlet 3.

[0034] In the embodiment, the cold or warm wind stream includes the stream component in the width direction of the louver 2 (in the transverse direction in the example shown in Fig. 2, that is, the direction of the shaft 5) because of a shape in which the center of the thermal insulator 8 in the louver width direction with which the cold or warm wind directly collides protrudes and the protruding portion is inclined along the left and right directions to be lowered. That is, as shown in Fig. 2, it is possible to obtain the advantage in which the stream of the blown air is distributed in the transverse direction by means of the protruding shape protruding the center of the louver 2 and the slope shape lowering from the protruding portion in the transverse direction so as to widen the transverse blowing range in the horizontal direction.

[0035] As the detailed example of forming the protruding shape of the center portion and the lowering slope shape in the transverse direction of the louver 2, ribs 50 are intermittently formed upright on the louver body 12 in the width direction thereof, the height of the rib 50 at the center of the louver body 12 in the width direction is set to be the highest, and then the heights of the other ribs 50 are gradually decreased toward the left and right

ends of the louver body 12. The thermal insulator 8 formed in a flat rectangular cube shape is fitted to the louver body 12 having such the ribs 50, thereby forming the louver 2. In the ribs 50, the heights of the ribs are sequentially decreased toward the left and right ends of the louver body, and hence the stream of the blown air is guided to the left and right ends of the louver body. As described above, since the heights of the ribs are gradually decreased in the width direction, the ribs 50 are used to blow the air in a direction facing four corners of the air outlets 4. In addition, since the louver 2 is formed in a cantilever structure and the louver length is increased, the louver 2 may be vibrated by the blown air. For this reason, the ribs 50 are used to reinforce the louver body 12 so as to prevent the vibration.

[0036] In addition, the invention is not limited to a configuration in which the ribs 50 having different heights are provided in the louver body 12. For example, the louver 2 may be formed in such a manner that the thermal insulator 8, having a shape in which the center portion protrudes and the left and right positions thereof are sequentially lowered in the width direction (the transverse direction), is fitted to the louver body 12 without the ribs 50. Further, regardless of the existence of the thermal insulator 8, the center portion of the structure of the louver 2 may protrude and the left and right positions thereof may be sequentially lowered in the transverse direction.

[0037] In the ribs 50 provided on the louver body 12, the heights thereof are gradually decreased in a direction from the center of the louver body to the left and right ends thereof, and the heights thereof are gradually decreased in a direction from the shaft 5 to the opening end. By means of the structure in which the heights of the ribs are gradually decreased, it is possible to allow the air blown from the air conditioner body to smoothly flow to the room.

[0038] The rotation force in the clockwise direction of the louver 2 in Fig. 1 is increased by the wind pressure of the cold or warm wind blown out from the air conditioner body due to the extended length (the length from the shaft to the opening end) of the louver 2. The spring 7 wound around the shaft 5 of the louver body 12 shown in Fig. 2 is used to resist the rotation force. Although the louver 2 is maintained to have a predetermined opening degree by the motor 10, when the wind pressure of the cold or warm wind is applied to the louver 2 so as to open the louver at the portion applied with the wind pressure, the opening force of the louver 2 is applied to the motor 10 and the opposite shaft 5. At this time, the spring 7 is used to resist the opening force.

[0039] In other words, during the operation of the air conditioner, when the louver 2 is rotated from a down blow mode to a horizontal blow mode (in a direction where the louver is closed toward the body 1) about the shaft 5 serving as a support point, all the blown air is received by the upper surface of the louver, and thus the force of the blown air is applied thereto. At this time, since the spring 7 is provided so as to assist the rotation torque, it

is advantageous in that the rotation driving torque upon closing the louver 2 is reduced. In addition, at the time when the louver 2 is closed toward the body 1 so as to be accommodated therein upon stopping the air conditioner, it is possible to reliably maintain the closed state by means of the force of the spring 7 acting in a direction where the louver 2 is closed.

[0040] Further, in the above-described embodiment, the air conditioner adopts a four-direction indoor unit, but the invention is not limited thereto. For example, the invention may be applied to a two-direction indoor unit or the like.

Claims

1. An in-the-ceiling type air conditioner comprising:

an air conditioner body (33) which is disposed in a ceiling (32);

a panel (35) which is provided on a bottom surface of said body (33);

an air inlet (37) which is provided at about a center of said panel (35) and sucks air from a room into said body (33);

an air outlet (41) which is provided in a periphery of said air inlet (37) and blows air to an inside of the room; and

a wind direction control louver (42) which is provided in said air outlet (41),

wherein one end of said louver (42) is provided in said panel (35) on a side of said air inlet (37) so as to be rotatable through a shaft (5), and the other end thereof is formed as an opening edge, and

wherein said opening edge exists on a more outer position than a portion of said louver (42) where blown air descending from an outermost side of said air outlet (41) contacts with said louver (42) when said louver (42) is opened at a maximum louver opening degree θ_{max} .

2. An in-the-ceiling type air conditioner comprising:

an air conditioner body (33) which is disposed in a ceiling (32);

a panel (35) which is provided on a bottom surface of said body (33);

an air inlet (37) which is provided at about a center of said panel (35) and sucks air from a room into said body (33);

an air outlet (41) which is provided in a periphery of said air inlet (37) and blows air to an inside of the room; and

a wind direction control louver (42) which is provided in said air outlet (41),

wherein one end of said louver (42) is provided in said panel (35) on a side of said air inlet (37)

so as to be rotatable through a shaft (5), and the other end thereof is formed as an opening edge, and

wherein a relationship between a length L1 of said air outlet in a direction perpendicular to said shaft (5) and a length L2 of said louver (42) in a direction perpendicular to said shaft (5) is $L2 > L1$, and a ratio $L2/L1$ is in a range of 1.4 to 1.8.

3. The in-the-ceiling type air conditioner according to claim 1 or 2,

wherein one end of said shaft (5) provided in the one end of said louver (42) is connected to a motor (10), and the other end of said shaft (5) is provided with a spring (7) which urges said louver (42) in a direction in which the louver (42) is closed.

4. The in-the-ceiling type air conditioner according to any one of claims 1 to 3,

wherein said louver (42) has a protruding portion provided at about a center in the transverse direction as a direction of said shaft (5) and a slope shape which is lowered in the transverse direction, and distributes a blown air stream descending via said air outlet (41) in the transverse direction.

5. An air conditioner comprising:

a body (33);

a panel (35) which is provided on a lower surface of said body (33) and includes an air inlet (37) and an air outlet (41); and

a wind direction control louver (42) which is provided in the air outlet (41) of the panel (35) so as to control a blow direction of blown air,

wherein one end of said louver (42) is rotatably provided in said air outlet (41) on a side of said air inlet (37) of said panel (35), and the other end thereof is adapted to be opened to a maximum louver opening degree θ_{max} from a position where said air outlet (41) is blocked by said louver (42),

wherein a front end of said louver (42) exists on a more outer side than a portion where blown air descending from an outermost side of said air outlet (41) contacts with said louver (42) when said louver (42) is opened at the maximum louver opening degree θ_{max} ,

wherein said louver (42) is rotatable to have an opening degree from a minimum louver opening degree θ_{min} to the maximum louver opening degree θ_{max} during an operation of said air conditioner, and

wherein said minimum louver opening degree θ_{min} is set to an opening degree capable of suppressing a ceiling surface (32) from being smudged due to a Coanda effect caused by the

- blown air even at the minimum louver opening degree θ_{\min} .
6. The air conditioner according to claim 5, wherein said minimum louver opening degree θ_{\min} is set so that an opening degree relative to a horizontal line is in a range of 15° to 35° , and wherein said maximum louver opening degree θ_{\max} is set so that an opening degree relative to the horizontal line is in a range of 35° to 55° .
7. The air conditioner according to claim 6, wherein said minimum louver opening degree θ_{\min} is set so that an opening degree relative to the horizontal line is in a range of 20° to 30° , and wherein said maximum louver opening degree θ_{\max} is set so that an opening degree relative to the horizontal line is in a range of 40° to 50° .
8. An air conditioner comprising:
- a body (33);
 - a panel (35) which is provided on a lower surface of said body (33) and includes an air inlet (37) and an air outlet (41); and
 - a wind direction control louver (42) which is provided in said air outlet (41) of said panel (35) so as to control a blow direction of blown air, wherein one end of said louver (42) is rotatably provided in said air outlet (41) on a side of said air inlet (37) of said panel (35), and the other end thereof is adapted to be opened to a maximum louver opening degree θ_{\max} from a position where said air outlet (41) is blocked by said louver (42), wherein by using a configuration in which a front end of said louver (42) exists on more outer side than a portion where blown air descending from an outermost side of said air outlet (41) contacts with said louver (42) when said louver (42) is opened at the maximum louver opening degree θ_{\max} , the front end of said louver (42) exists on a sufficiently far outside of the outermost side of said air outlet (41) at a minimum louver opening degree θ_{\min} during an operation of the air conditioner, so that air is prevented from being blown from a rear surface of said louver (42) and a non-uniform temperature and an uncomfortable feeling caused by a contact with a wind are prevented by uniformly distributing the air blown from said air outlet (41) to a far position along said louver (42) in the substantially horizontal direction.
9. An in-the-ceiling type air conditioner comprising:
- an air conditioner body (33) which is disposed in a ceiling (32);
 - a panel (35) which is provided on a bottom surface of said body (33);
 - an air inlet (37) which is provided at about a center of said panel (35) and sucks air from a room into said body (33);
 - an air outlet (41) which is provided in the periphery of the air inlet (37) and blows air to an inside of the room; and
 - a wind direction control louver (42) which is provided in said air outlet (41), wherein said louver (42) is formed in a cantilever structure in which one end of said louver (42) is provided in said panel (35) on a side of said air inlet (37) so as to be rotatable through a shaft (5) and the other end thereof is formed as an opening end, and wherein said louver (42) has a protruding portion provided at about the center in a transverse direction as the direction of said shaft (5) and a slope shape lowered in the transverse direction, and distributes a blown air stream descending via said air outlet (41) in the transverse direction.
10. The in-the-ceiling type air conditioner according to claim 9, wherein said louver (42) includes a louver body (12) and a thermal insulator (8) which is fitted onto said louver body (12), and wherein a rib (50) having a height forming a protruding portion is formed at about the center in the transverse direction of said louver body (12) and other ribs (50) are intermittently formed therein so as to be lowered toward the left and right ends of said louver body (12) in the transverse direction.
11. The in-the-ceiling type air conditioner according to claim 10, wherein the left and right ends of said louver body are respectively provided with stoppers (9) to which said thermal insulator (8) is fitted, and wherein said thermal insulator (8) is separably fitted onto said louver body (12) via a gap between said louver body (12) and said stoppers (9).
12. The in-the-ceiling type air conditioner according to claim 9, wherein said louver (42) includes a louver body (12) which is flat in the transverse direction and a thermal insulator (8) which is fitted onto said louver body (12), and wherein said thermal insulator (8) is formed in a protruding portion formed at about a center in the transverse direction and a slope shape lowered toward the left and right ends of said thermal insulator (8) in the transverse direction.
13. The in-the-ceiling type air conditioner according to any one of claims 9 to 12,

wherein one end of said shaft (5) provided in the one end of said louver (42) is connected to a motor (10), and the other end of said shaft (5) is provided with a spring (7) which urges said louver (42) in a direction in which said louver (42) is closed. 5

14. An air conditioner comprising:

a body (33);
 a panel (35) which is provided on a lower surface of said body (33) and includes an air inlet (37) and an air outlet (41); and 10
 a wind direction control louver (42) which is provided in said air outlet (41) of said panel (35) so as to control a blow direction of blown air, wherein said louver (42) is formed in a cantilever structure in which one end of said louver (42) is provided in said panel (35) on a side of said air inlet (37) so as to be rotatable through a shaft (5) and the other end thereof is formed as an opening end, and 15
 wherein said louver (42) is formed in a protruding portion formed at about a center in the transverse direction as a direction of said shaft (5) and a slope shape lowered in the transverse direction, and allows a blown air stream descending via said air outlet (41) to flow along said louver (42) and to be distributed in the transverse direction. 20
 25

15. The air conditioner according to claim 14, wherein a concave portion is formed in a portion of said panel (35) located at about the center between an outermost portion of said panel (35) and the outermost side of said air outlet (41), and 30
 wherein when said louver (42) is in a closed state, a front end of said louver (42) is located at said concave portion so that a rear surface of said louver (42) is substantially located at the same level as that of a front surface of said panel (35). 35
 40

45

50

55

FIG. 1

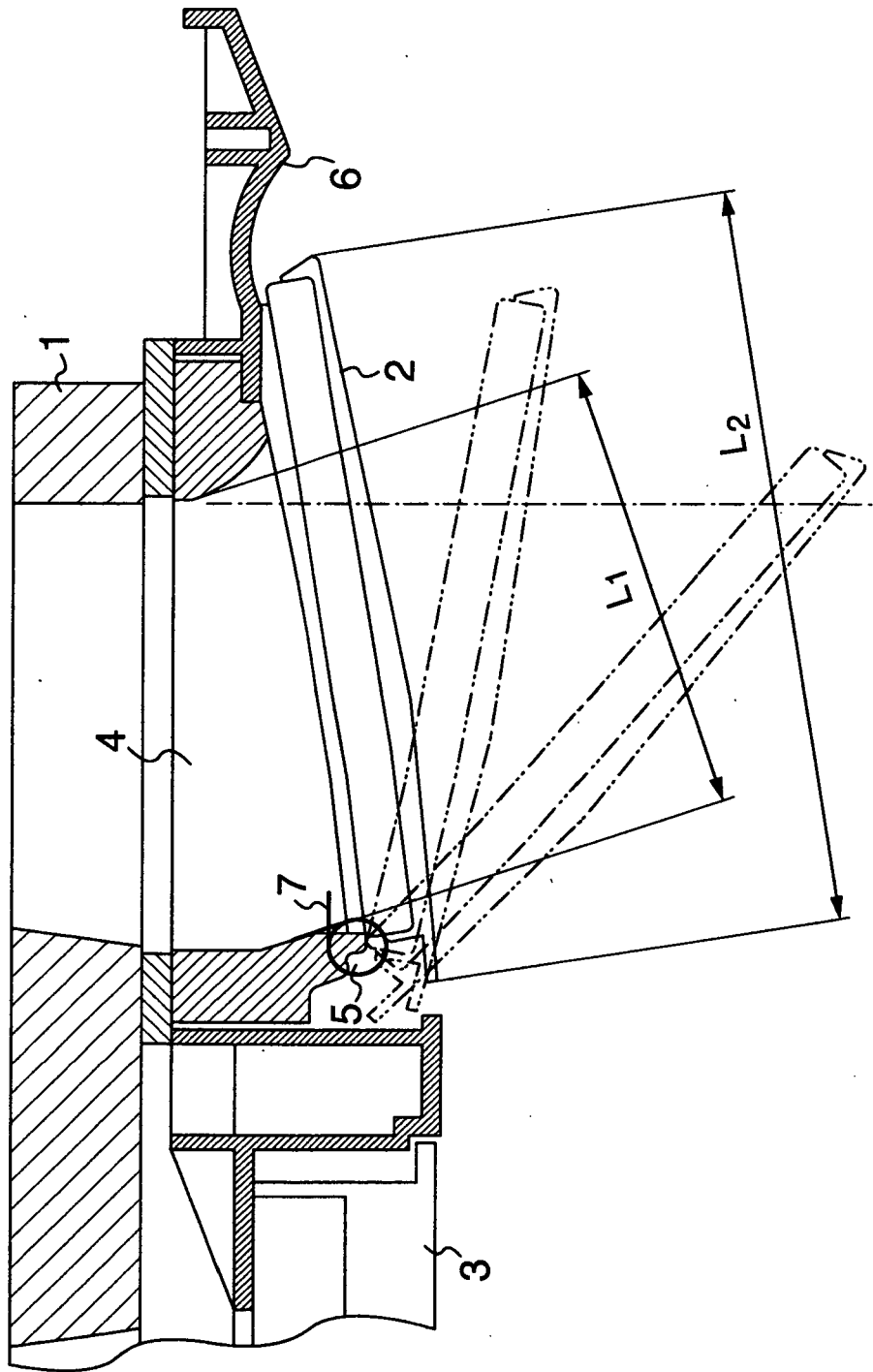

FIG. 2

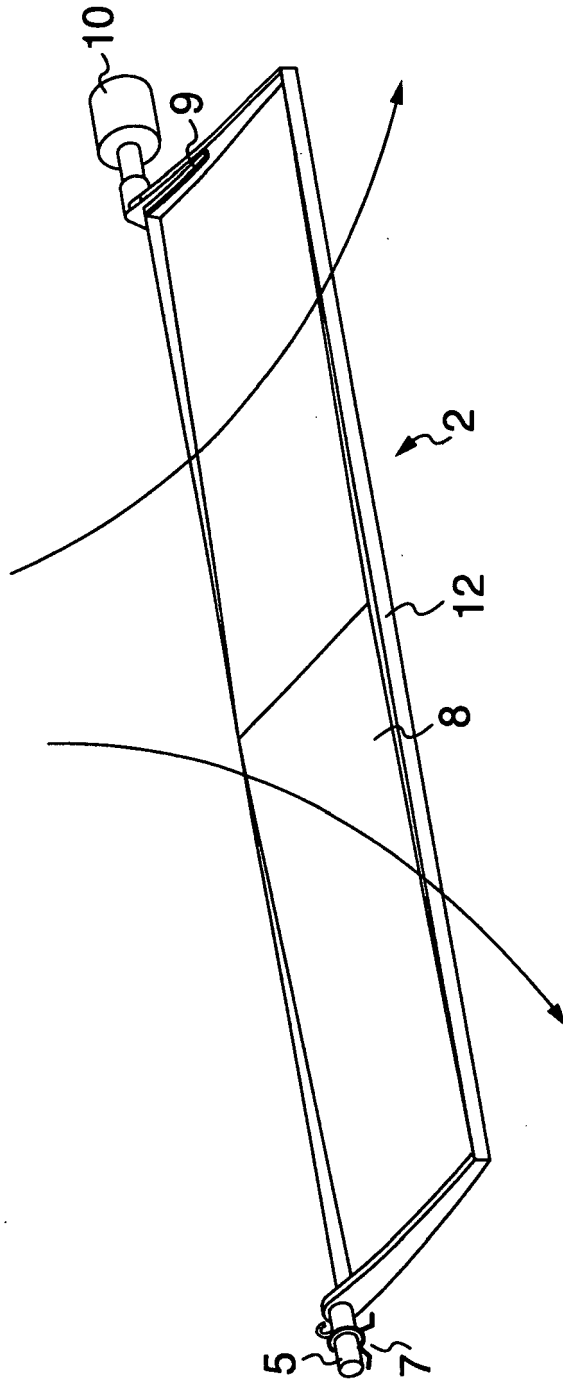

FIG. 3

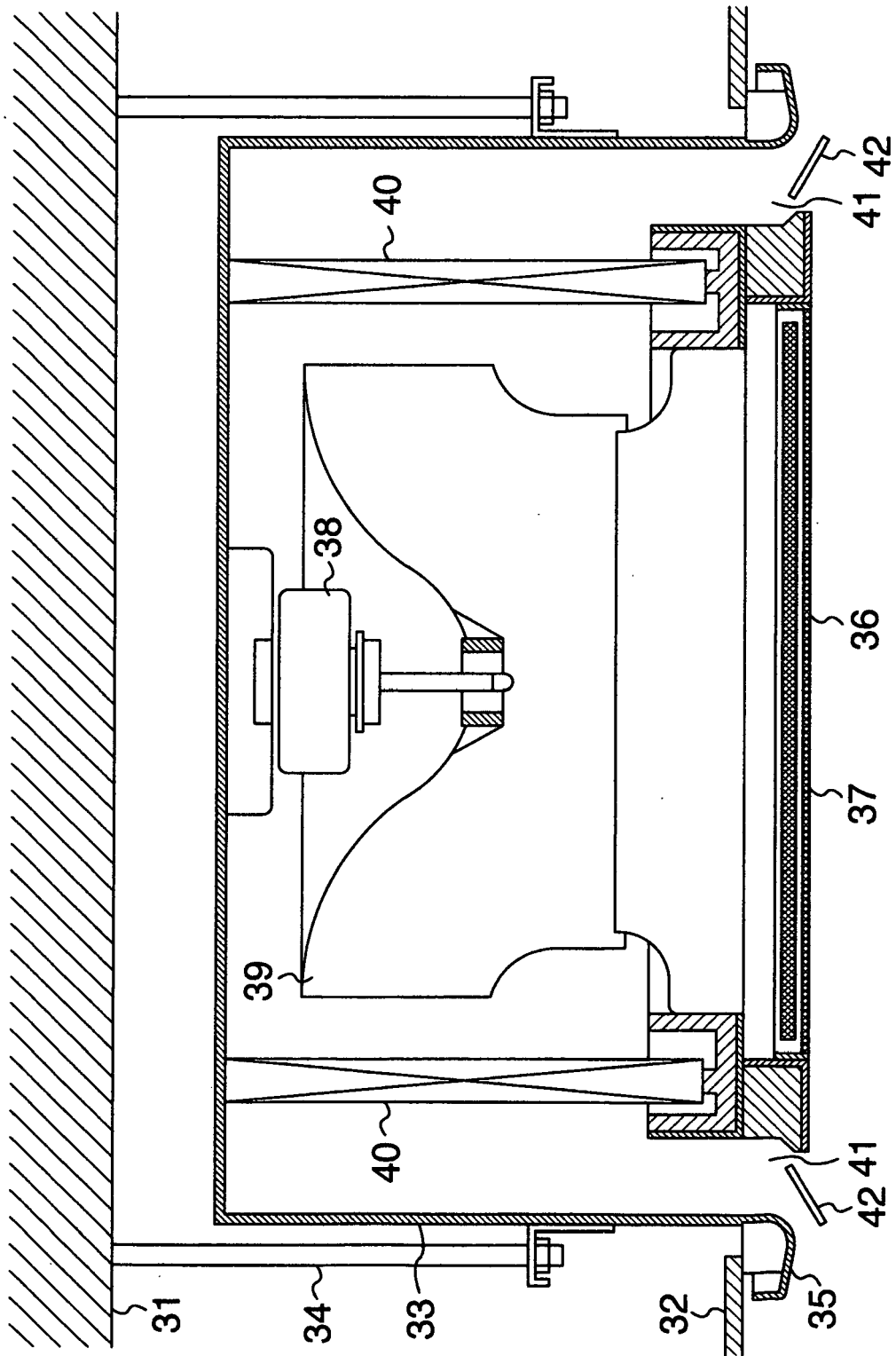
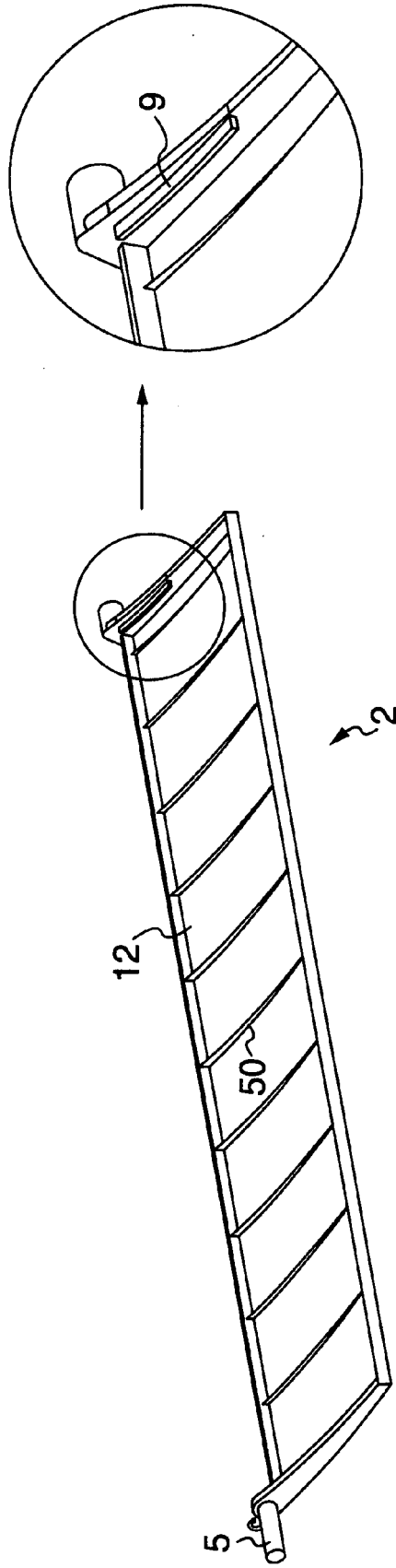

FIG. 4



REFERENCES CITED IN THE DESCRIPTION

This list of references cited by the applicant is for the reader's convenience only. It does not form part of the European patent document. Even though great care has been taken in compiling the references, errors or omissions cannot be excluded and the EPO disclaims all liability in this regard.

Patent documents cited in the description

- JP 2007322114 A [0003] [0005]
- JP 2006336961 A [0004] [0006]