

[54] BRUSH UNIT AND REPLACEMENT BRUSH THEREFOR

[76] Inventor: James S. Smith, Sr., 2443 Armstrong Cir., Gastonia, N.C. 28052

[22] Filed: Jan. 23, 1973

[21] Appl. No.: 326,021

[52] U.S. Cl. 15/179, 15/181

[51] Int. Cl. A46b 1/00, A46b 13/02

[58] Field of Search 15/179, 180, 181, 182, 15/183, 198, 200

[56] References Cited

UNITED STATES PATENTS

1,838,416	12/1931	Lecker.....	15/179
3,038,189	6/1962	Harr.....	15/181

FOREIGN PATENTS OR APPLICATIONS

656,972	2/1938	Germany	15/179
786,788	11/1957	Great Britain	15/181

Primary Examiner—Peter Feldman
Attorney, Agent, or Firm—Wellington M. Manning, Jr.

[57] ABSTRACT

A brush unit is disclosed where a central hub is employed having a mounting opening for receiving a drive shaft therethrough and a plurality of T shaped slots around the outer periphery thereof. A ring brush is receivable around the hub and has a plurality of projections around the inner periphery of a brush body, the projections being receivable in the T-shaped slots for holding the ring brush on the hub. The projections pass into the slots through a leg of the T and move to either end of the cross of the T upon rotary motion of the hub, the particular end being determined by the direction of the rotary motion. The projections are held thereat so long as the driving relationship exists. Once the rotary motion of the hub ceases, the brush may be moved back to the leg area of the T where the projections may be removed to remove the brush from the hub. A plurality of bristles are provided around the brush body on the outer periphery thereof. The replacement brush per se is also claimed.

13 Claims, 6 Drawing Figures

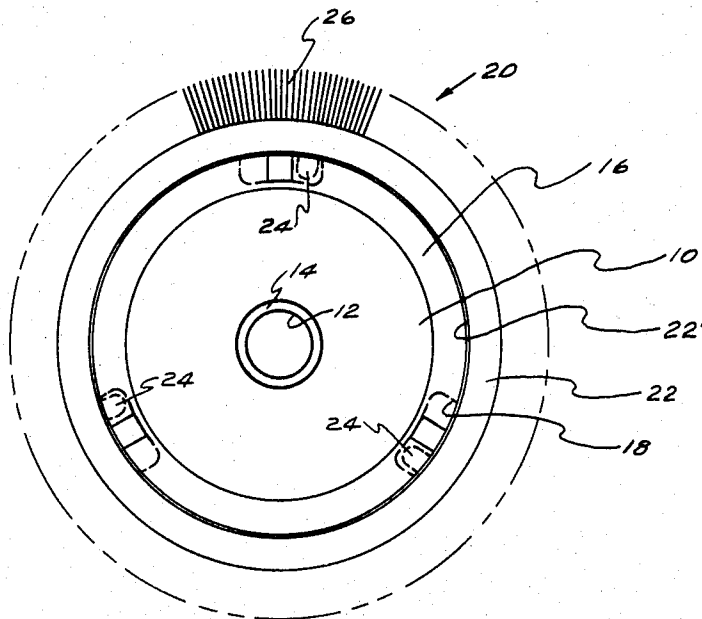

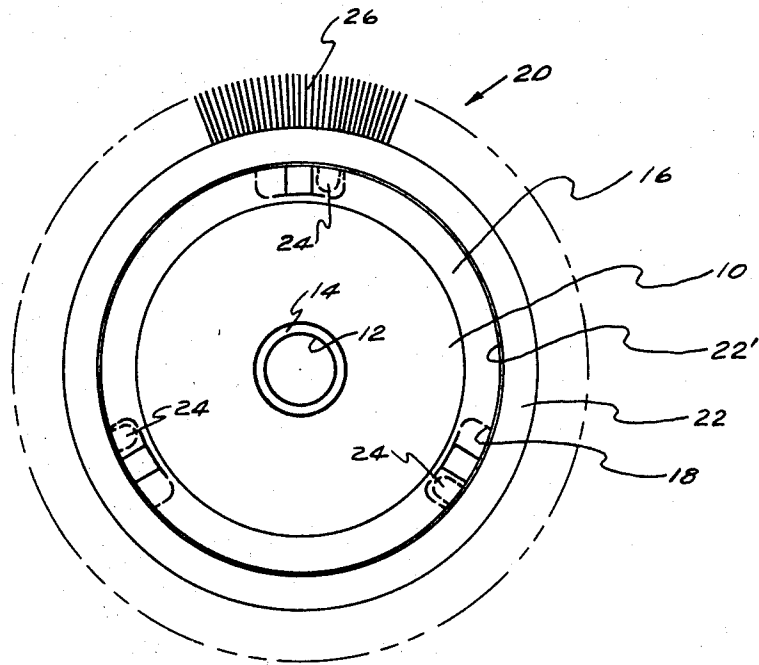

FIG. 1

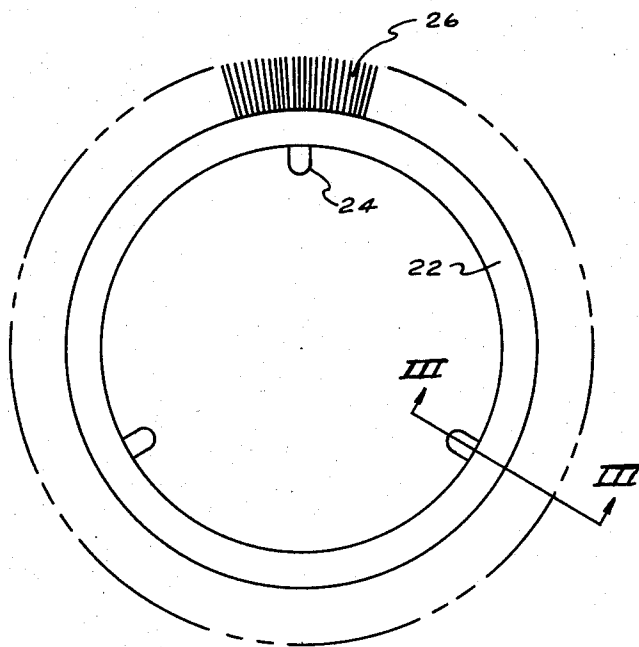

FIG. 2

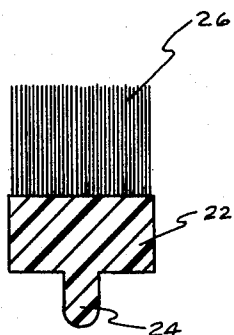

FIG. 3

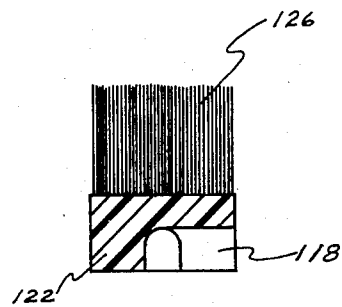

FIG. 3-A

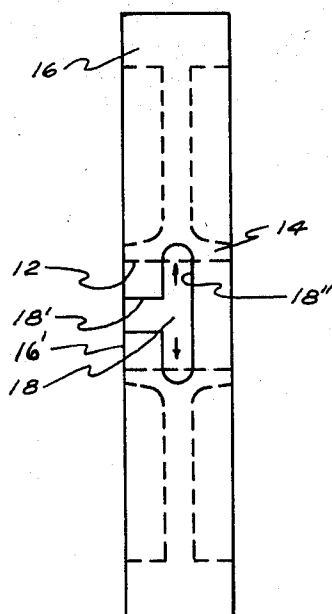

FIG. 4

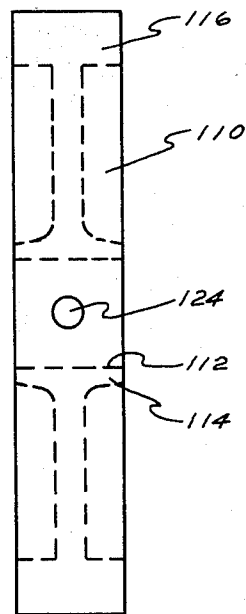

FIG. 4-A

BRUSH UNIT AND REPLACEMENT BRUSH THEREFOR

BACKGROUND OF THE INVENTION

Brushes of the general type described herein along with other devices have heretofore been used in tenter frames to engage a textile fabric being fed into the frame and force the fabric onto pins that hold the fabric at open width during passage through the frame. Normally the brushes so employed are of integral construction whereby it becomes necessary to disrupt operation of the tenter frame during removal of worn out or damaged brushes and replacement of new or rebuilt brushes therefor. Stopping the tenter frame, of course, reduces the production output of same and is a costly maneuver for the finishing plant, not to mention the cost of new or rebuilt prior art brushes.

Brushes of the general type described herein likewise are suitable for other various uses where prior art brushes of integral construction have heretofore been employed. In fact, the brushes of the present invention could replace many integral units where wearing or damage to the unit is probable. As such, the instant brush units may be employed in numerous cleaning, brushing and other operations.

The brush of the present invention represents a vast improvement over prior art tenter frame brushes, in that, the separate removable or replacement brush may be slipped onto the core or hub while the tenter frame is in operation, thus providing an easy means for insuring good quality tenter frame brushes at all times. Moreover, the economics of manufacture of the replacement brush is such that the system of the present invention is much more economical than new or rebuilt integral brushes.

The prior art, while fairly voluminous in this general technological area, is devoid of any teaching or suggestion of the brush of the present invention. Exemplary of the prior art are U.S. Pat. Nos. 909,204 to Nielson; 1,383,511 to Baral; 1,561,280 to Radinse; 1,637,823 to Herold; 2,324,272 to Anderson; 2,534,892 to Wilhide; 2,609,559 to Peterson; 3,121,245 to Tilgner; 3,253,291 to Nelson; and 3,289,234 to Nelson.

SUMMARY OF THE INVENTION

It is an object of the present invention to provide an improved brush unit utilizing a replaceable brush element.

Another object of the present invention is to provide an improved brush unit for a tenter frame.

Still another object of the present invention is to provide a novel replacement ring brush for a brush unit.

Generally speaking, the brush unit of the present invention comprises a hub, said hub having a mounting opening therein, said hub further having brush connector means positioned around the outer periphery thereof, and a brush element removably secureable around said hub, said brush element having a body with an inside periphery substantially conforming to the outer periphery of said hub, said inside periphery of said body having connector means thereon, said connector means on said body mating with connector means on said hub to removably secure said brush to said hub, said body further having bristles secured thereto around the outer periphery thereof.

More specifically, the brush unit of the present invention provides a core or hub that may be permanently secured to a rotary shaft or the like after which ring brushes may be removably secured thereto as desired.

The hub is thus provided with connector means as is the ring brush, with the connector means of the two elements being mateable to removably secure the ring brush to the hub. In a preferred embodiment, slots are provided in the outer periphery of the hub so as to receive projections located on the inner periphery of the ring brush, the projections loosely residing in the slots and being held therein during rotational movement of the hub in either a clockwise or counterclockwise direction.

Most preferably, the hub is circular in form and has a thickened flange around the outer periphery thereof with the slots extending down into the thickened flange. The most preferred form of the slots is T-shaped with a leg of the T extending through the sidewall of the flange and permitting direct access for the projections located on the inner periphery of the ring brush body. The projections thus extend long the leg of the T to approximately the center of the flange where the cross member of the T-shaped slots is present. When the projections are aligned with the cross member of the slots, the hub may rotate with respect to the brush until the end of the slots engage the projections. Thereafter, rotary motion of the hub is transmitted to the brush through the projections. During this driving engagement, the sidewalls of the slots preclude any substantial transverse movement of the projections and thus hold the brush on the hub.

Slots according to the present invention thus have an access area where the projections may move into and out of the slots and a driving area where the ends or other portions of the slots engage the projections and transmit a driving force to the brush. In this regard, while a T-shaped slot is greatly preferred, the shape of the slot may take other forms.

A construction according to the teachings of the present invention thus permits the hub to be permanently secured to a shaft or axel and be driven thereby. Likewise, a ring brush may be slipped onto the hub when the projections or the like are in alignment with the access areas of the slots. Once the projections extend to the driving area of the slots, the hub or brush may be rotated in a clockwise or counterclockwise direction to temporarily unite the brush to the hub. When removal of the brush is desired, a simple turning of the brush in the direction opposite the previous direction of rotation to again align the projections with the access area of the slots will permit the brush to be slipped off the hub and discarded or the like. Thereafter, a new brush may be placed on the hub in a manner of seconds, even while the machine is operating in most situations.

Economics plays a large part in the selection of materials for manufacture of the brush of the present invention. As such, it is preferable to mold by injection molding or other techniques both the hub and the ring brush body. The connector means for both the hub and the body may thus be made integral with their respective parts during molding or may be later provided as desired. Furthermore, though the hub has been described having the slots therein, the slots may likewise be presented in the ring body with the projections being located on the hub.

BRIEF DESCRIPTION OF THE DRAWINGS

FIG. 1 is a side view of an assembled brush unit according to the teachings of the present invention.

FIG. 2 is a side view of a ring brush according to the teachings of the present invention.

FIG. 3 is a cross sectional view of a ring brush as shown in FIG. 2 taken along lines III—III.

FIG. 3A is a cross-sectional view of a ring brush showing a further embodiment thereof according to the teachings of the present invention.

FIG. 4 is an end view of a hub according to the teachings of the present invention.

FIG. 4A is an end view of a hub according to the teachings of the present invention illustrating a further embodiment thereof.

DESCRIPTION OF THE PREFERRED EMBODIMENTS

Referring to the Figures, preferred embodiments of the present invention will now be described in detail. In FIGS. 1, 2, 3 and 4 a brush unit according to the teachings of the present invention is illustrated. A core or hub 10 is provided having a centrally located mounting hole 12 through which a drive element such as a mandrel, axel, shaft or the like may pass and be secured to hub 10. Preferably, mounting opening 12 has a flange 14 surrounding same and extending outwardly in opposite directions from hub 10. Hub 10 further has a thickened flange 16 surrounding the outer periphery thereof with connector means located therearound. Preferably, the connector means are a plurality of slots 18 illustrated as having a T-shaped configuration. A ring brush generally indicated as 20 is received around hub 10 and comprises a body 22 having an inner periphery that conforms to the outer periphery of hub 10 and is sized to loosely reside therearound. Body 22 further has connector means received around the inner periphery thereof to mate with connector means located in hub 10. The brush connector means are preferably a plurality of projections 24 that are adapted to mate with slots 18 on hub 10 so as to removably secure brush 20 to hub 10. Body 22 further has a plurality of bristles 26 provided around the outer periphery thereof.

Hub 10 is best illustrated in FIGS. 1, 4 and 4A, and is preferably circular as shown. Mounting opening 12 and flange 14 receive a shaft or the like and is secured therearound by any suitable means. Hub 10 further has connector means received in flange 16 therearound. Preferably the connector means are a plurality of T shaped slots 18 equidistantly spaced around the periphery of hub 10, slots 18 having an access area or leg 18' and a cross member or driving section 18''. Access areas 18' extend completely through the sidewall 16' of flange 16 to receive brush connector means 24 therein. As shown in FIG. 4A, however, hub 110 may be provided with a series of projections 124 around the periphery of flange 116 in lieu of slots. For either embodiment, a complementary connector means is located on the inner periphery 22' of brush 20 to removably secure the brush to the hub.

Brush 20 is best illustrated in FIGS. 2, 3 and 3A. A preferred form of body 22 is annular to reside around a circular hub 10 with the inner circumference 22' conforming in shape to the outer circumference 11 of hub 10 and being slightly larger than hub 10. A plurality of projections 24, illustrative of connector means, are

equidistantly spaced around inner circumference 22' and extend inwardly therefrom, said projections being in alignment for receipt in slots 18 of hub 10 and being the same in number. As illustrated in FIG. 3A, however, body 22 of the brush may have a plurality of slots 118 spaced therearound in lieu of projections 24 of FIG. 3. In any event, the particular connector means should be receivable by the connector means on hub 10 to removably secure brush 20 thereto. Body 22 further has a plurality of bristles 26 secured thereto in suitable fashion.

Body 22 and hub 10 are preferably designed to have substantially the same width at the widest points thereof with the connector means being centrally located along each part. As such, the assembled brush unit has a good appearance and brush 20 is evenly supported by hub 10 across the width thereof.

Making reference to FIGS. 1, 2, 3 and 4, hub 10 would be mounted for rotation at opening 12. A brush 20 would then be brought adjacent hub 10 where projections 24 are aligned with access areas 18' of T shaped slots 18. Brush 20 is then forced against hub 10 whereby projections 24 move along access areas 18' until in communication with cross members 18'', at the approximate mid point of hub 10. Projections 24 are of a dimension to reside loosely within slots 18 and are of a length slightly longer than the depth of slots 18. Rotary motion imparted to hub 10 permits free rotary motion of hub 10 with respect to brush 20 until the ends of slots 18 engage projections 24. At this point, access areas 18' of slots 18 have moved out of alignment with projections 24 and removal of brush 20 is precluded. Likewise, continued rotational movement of hub 10 is imparted to brush 20 through projections 24 and hub 10 and brush 20 thus move as a unit. T-shaped slots 18 have a cross member on both sides of access areas 18'. Hence the above described procedure occurs regardless of the direction of rotary movement. Furthermore, should the connector means be reversed, i.e., the projections be located on hub 10 and slots on brush 20, the same principles would apply.

After using the brush unit of the present invention and it becomes necessary to replace brush 20, brush 20 can be rotated in a direction opposite the last direction of rotation of hub 10 until projections 24 are in alignment with access areas 18' of slots 18. Brush 20 can then be slipped off hub 10 and a replacement brush 20 placed thereon.

Preferably, the component parts of the present invention are produced by injection molding techniques from a plastic composition. As such, the connector means for the hub and ring brush are integral with their respective parts. Furthermore, while any type bristles may be employed around the outer periphery of ring brush 20, natural bristles and polyamide filaments are preferred.

Having described the present invention in detail, it is obvious that one skilled in the art will be able to make variations and modifications thereto without departing from the scope of the invention. Accordingly, the scope of the present invention should be determined only by the claims appended hereto.

What is claimed is:

1. A brush unit comprising a hub, said hub having a mounting opening therethrough, and a brush removably secureable around said hub, said brush having a body with an inside periphery substantially conforming

5

6

in shape to an outside periphery of said hub, one of said hub and said brush having a plurality of elongated slots extending circumferentially therearound and having a side opening intermediate the length thereof and the other of said hub and said brush having a plurality of projections thereon, said projections being passable through said intermediate openings into said slots and drivingly connecting said brush and said hub away from said openings.

2. A brush unit as defined in claim 1 wherein the slots and opening define a T.

3. A brush unit comprising:

a. a circular hub said hub having a centrally located mounting opening therethrough, said hub further having a thickened flange around an outer periphery thereof, said flange having a plurality of elongated slots circumferentially therearound, each of said slots having a side opening intermediate the length thereof; and

b. a brush removably secureable to said hub, said brush comprising a ring having an inner periphery of a size to loosely reside around said outer periphery of said hub, said ring having a plurality of projections around the inner periphery thereof, said projections being receivable in said elongated slots, and said brush having a plurality of bristles around the outer periphery thereof.

4. A brush unit as defined in claim 1 wherein said hub is circular in shape and has a flange around the outer periphery thereof, said connector means being located at said flange.

5. A brush unit as defined in claim 4 wherein said body is annular in shape.

6. A brush unit as defined in claim 1 wherein said slots are provided on said hub.

7. A brush unit as defined in claim 1 wherein said slots are provided on said body.

8. A brush unit as defined in claim 1 wherein said hub and said body are molded.

9. A brush unit as defined in claim 1 wherein said bristle elements comprise polyamide filaments.

10. A brush unit as defined in claim 3 wherein the hub and the ring are molded of a plastic composition.

11. A brush unit as defined in claim 10 wherein the bristles are polyamide filaments.

12. A brush unit as defined in claim 11 wherein said slots are T-shaped.

13. A brush unit as defined in claim 12 wherein three slots and three projections are provided, each equidistantly spaced around the periphery of its respective part.

* * * * *

30

35

40

45

50

55

60

65