

(No Model.)

W. F. KRAMER & C. F. WEINMAN.  
FIFTH WHEEL.

No. 526,494.

Patented Sept. 25, 1894.

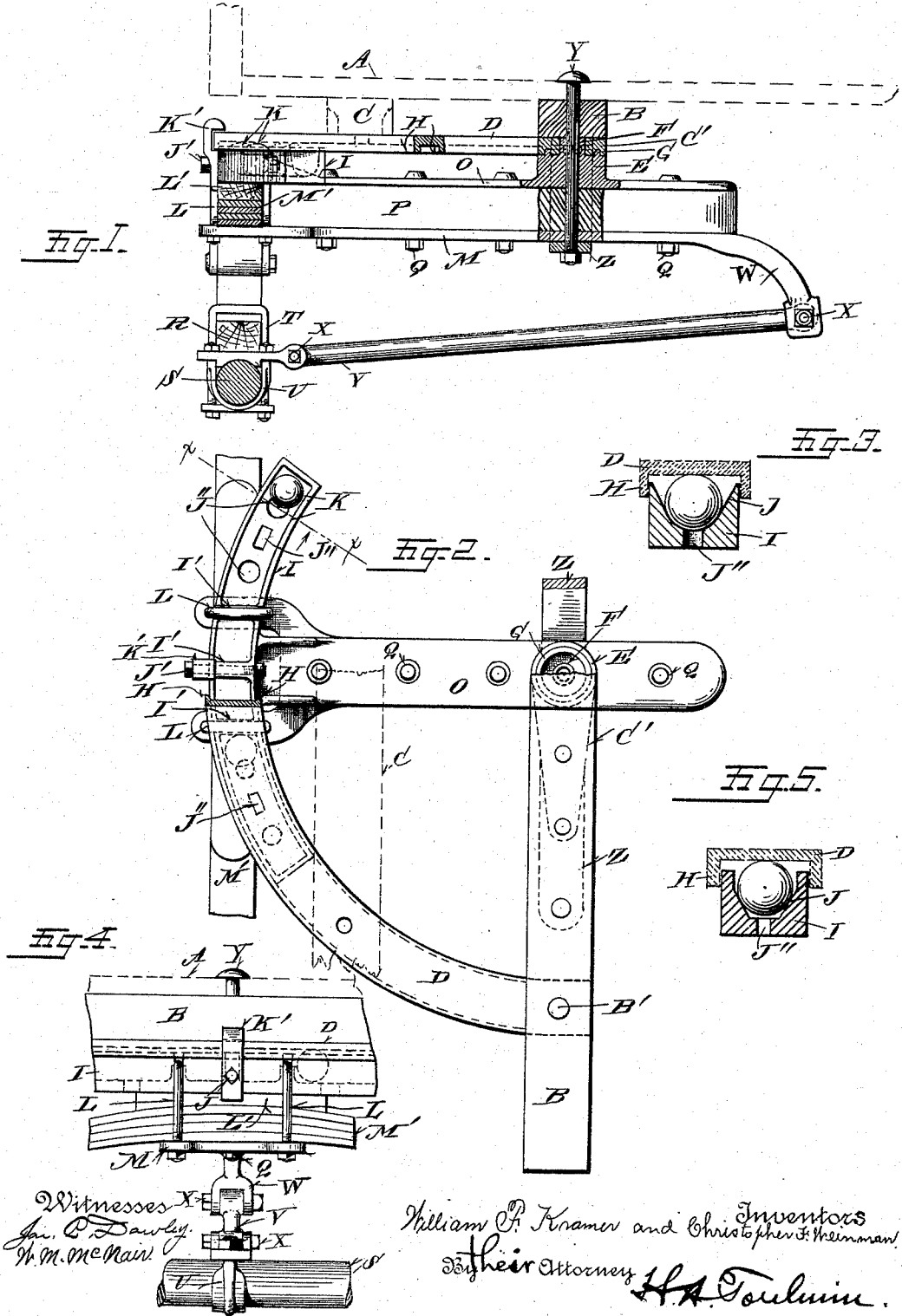

Witnesses  
J. P. Dawley  
W. M. McMain

William F. Kramer and Christopher Weinman  
Inventors  
By their Attorneys  
H. A. Pauline.

# UNITED STATES PATENT OFFICE.

WILLIAM F. KRAMER AND CHRISTOPHER FREDERICK WEINMAN, OF DAYTON, OHIO, ASSIGNORS TO KRAMER, WEINMAN & CO., OF SAME PLACE.

## FIFTH-WHEEL.

SPECIFICATION forming part of Letters Patent No. 526,494, dated September 25, 1894.

Application filed May 10, 1894. Serial No. 510,701. (No model.)

*To all whom it may concern:*

Be it known that we, WILLIAM F. KRAMER and CHRISTOPHER FREDERICK WEINMAN, citizens of the United States, residing at Dayton, in the county of Montgomery and State of Ohio, have invented certain new and useful Improvements in Fifth-Wheels, of which the following is a specification, reference being had therein to the accompanying drawings.

This invention relates to certain new and useful improvements in running gears and it has reference to that part of the gear constituted of the fifth wheel.

The general object of the invention is to provide a fifth wheel which shall be attached to the body or body bolster at one end and shall be supported by the vehicle spring at the other end, whereby the usual perch or reach pole shall be eliminated, whereby the rear end of the fifth wheel which is attached to the body may rise and fall or vibrate vertically with the forward end which is subject to such vibration by reason of being supported upon the spring, and whereby, incidentally, the vehicle may be turned around in a short space by the rear location of the king-bolt and yet the bearing be extended from such rear location to a forward position over the spring. This object is carried into operation by the means hereinafter fully described, and the peculiarities of which are pointed out in the claims.

In the accompanying drawings on which like letters of reference indicate corresponding parts: Figure 1, represents a partial side elevation and sectional view of our fifth wheel; Fig. 2, a plan view thereof; Fig. 3, a transverse sectional view on the line *xx* of Fig. 2; Fig. 4, a front elevation showing a part of the fifth wheel and the connection with the spring; Fig. 5, a transverse sectional view showing a slightly modified form of lower fifth wheel plate.

In Fig. 1 a wagon body or a portion of one is designated by the letter A, and this body is provided with cross-pieces or bolsters B and C. The upper plate D of the fifth wheel is secured strongly to the bolster C and is secured at its rear end to the bolster B. (See Fig. 2 at B'.) A plate C' is also fastened to the bolster B and is pivoted upon a block E

having a neck F and a circular bead G. The plate C' is bored to fit the neck F and grooved to fit the bead G. The plate D is also provided with flanges H which fit against the sides of the lower plate I of the wheel to prevent dislocation of the upper plate from the lower or to assist in keeping them together and also to exclude dust and other foreign matter. The plate I is grooved, as shown at J, and has a series of holes or slots J' to allow whatever grit or dust may work in past the flanges H, if any, to pass out. Within this groove or channel are placed a number of antifriction balls or bearings K upon which the top plate D rests so as to afford a ball bearing between the two plates.

The plate I is fastened by means of clips L to a longitudinal iron M and cast or formed with another longitudinal iron O. These irons are secured to a wooden bar P by bolts Q. It is upon the upper iron that the block E is formed. The plate I, preferably, has partitions I' through the middle one of which a bolt J' passes to hold a hook or retainer K', which extends over the upper plate D. As seen in Fig. 4 the lower plate I is notched where the clips L pass across it so as to bring the clips below the upper surface of the plate I. The block of wood L' is placed between the spring M' and the lower plate I to afford a flat surface for the plate. The clips L also embrace the spring. One or more antifriction balls K are placed between the partitions themselves, and the outer partitions and the ends of the plate. The partitions I' are not indispensable but they give rigidity to the plate I.

The usual capping R is applied to the axle S and held by the usual clips T. The clip U on the axle is connected by a rod V to an extension W of the iron M by bolts or pivots X to permit of the vibratory motions which take place. The king-bolt Y passes through the vehicle body, the bolster B and block E and the beam P and iron M.

Thus it will be seen that the rear of our fifth wheel is attached to the body and rides up and down with it, while the forward end is supported by the spring, and with the spring and with the body vibrates up and down. Thus also the reach-pole is eliminated

while the strength of the structure is not im-  
paired and while the vehicle may turn in a  
shorter space. The remarks here made are  
based upon practical experience with the de-  
5 vice, since it has been made, applied and  
tested in a regular practical way. A brace Z  
receives the lower end of the king-bolt and  
extends up and is attached to the bolster B.

10 Having thus fully described our invention,  
what we claim as new, and desire to secure by  
Letters Patent, is—

1. In a fifth wheel, the combination with a  
flanged upper plate D, a grooved lower plate  
I overlapped by the flanges H of the upper  
15 plate, antifriction balls in the grooved plate  
and supporting the flanged plate, a hook or  
catch secured to one of the plates and extend-  
ing over the other, a body having bolsters C  
and B, to both of which said upper plate is  
20 fastened, a plate O connected to the lower plate I  
and having a block E upon which rests the  
plate C', a plate M also secured to the plate  
D, a king-bolt passing through the wheel bol-

ster, the plate C', the block E and the plate 25  
M, a forward axle, a spring carried thereby,  
and clips connecting the plate D and plate M  
to the spring, and a brace Y connecting the  
axle and the rear end of the plate M.

2. In a fifth wheel, the combination with 30  
the spring, of a lower grooved plate I having  
partitions, clips securing said plate to the  
spring, said clips being over said partitions  
and let into the upper surface of the plate so  
as to be substantially flush therewith, an up- 35  
per plate D fitting over the lower plate, a  
hook secured to one plate and engaging the  
other to prevent their separation, and anti-  
friction balls within the lower plate and sup-  
porting the upper plate. 40

In testimony whereof we affix our signatures  
in presence of two witnesses.

WILLIAM F. KRAMER.  
CHRISTOPHER FREDERICK WEINMAN.

Witnesses:

GEO. W. FRANK,  
JOHN L. H. FRANK.