

J. J. JOHNSTON.

METHOD OF MAKING BLANKS FOR SHOVELS, &c.

No. 385,809.

Patented July 10, 1888.

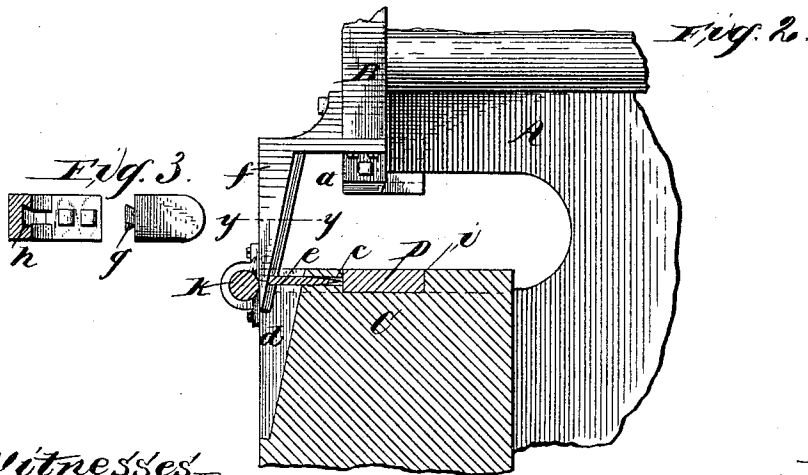
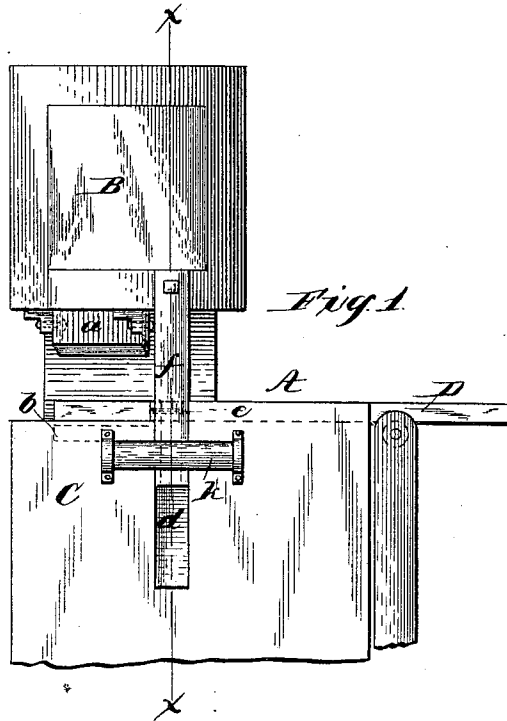

Witnesses
 Wm. H. Scott.
 Wm. E. Dyer.

Inventor.
 J. J. Johnston.
 By Johnston, Reinold & Dyer,
 his Attorneys.

J. J. JOHNSTON.

METHOD OF MAKING BLANKS FOR SHOVELS, &c.

No. 385,809.

Patented July 10, 1888.

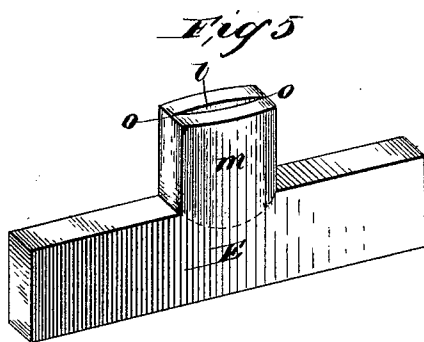
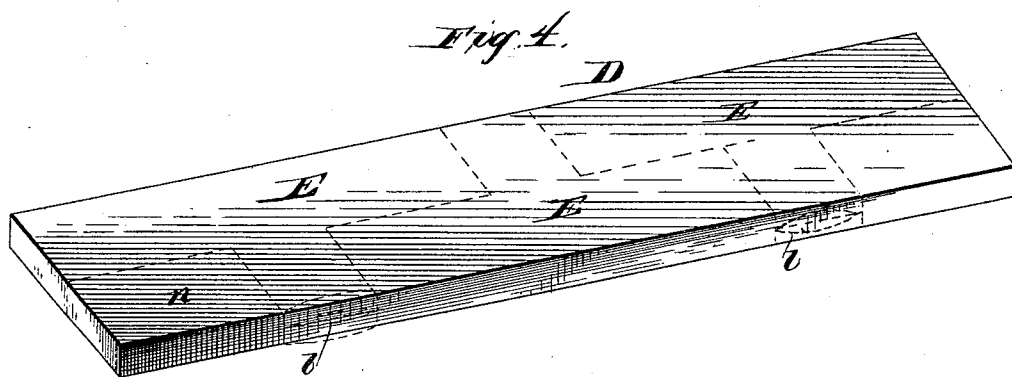

Witnesses—
 Wm. H. Scott.
 Wm. E. Dyer.

Inventor,
 J. J. Johnston.
 By Johnston, Reinhardt & Co.
 his Attorneys.

UNITED STATES PATENT OFFICE.

JAMES J. JOHNSTON, OF COLUMBIANA, OHIO, ASSIGNOR TO HENRY M. MYERS, OF BEAVER FALLS, PENNSYLVANIA.

METHOD OF MAKING BLANKS FOR SHOVELS, &c.

SPECIFICATION forming part of Letters Patent No. 385,809, dated July 10, 1888.

Application filed March 26, 1888. Serial No. 268,521. (No model.)

To all whom it may concern:

Be it known that I, JAMES J. JOHNSTON, a citizen of the United States, residing at Columbiana, in the county of Columbiana and State of Ohio, have invented certain new and useful Improvements in Methods of Manufacturing Blanks with Split Tangs; and I do hereby declare the following to be a full, clear, and exact description of the invention, such as will enable others skilled in the art to which it appertains to make and use the same.

My invention relates to the art of shovel-making; and it consists in a method of manufacturing blanks for shovels and other articles with a split tang.

The invention will be hereinafter described, and particularly pointed out in the claim.

In the accompanying drawings, which form a part of this specification, Figure 1 represents a front elevation; Fig. 2, a vertical section on the line *x x*, Fig. 1. Fig. 3 is a plan in detail on line *y y*, Fig. 2; Fig. 4, an enlarged perspective of a bar, showing blanks in dotted lines; and Fig. 5, a similar view of a blank cut from a bar.

Reference being had to the drawings and the letters marked thereon, A represents an ordinary cutting or punching machine, provided with a stop-motion (not shown) and with a reciprocating head, B, to which is detachably secured a knife, *a*, and in the lower part or anvil, C, of the machine is also detachably secured a corresponding die, *b*. In the anvil is formed a horizontal transverse slot, *c*, and a vertical angular slot, *d*—the former to receive a knife, *e*, and the latter to receive a wedge, *f*, attached to the head of the machine. The outer end of the knife *e* is provided with a dovetailed head, *g*, which engages with a groove, *h*, in the inner surface of the wedge. By this construction the knife *e* is forced into the edge of the bar D, while lying in the longitudinal groove or slot *i* in the upper surface of the anvil, by the downstroke of the head B and withdrawn by the upstroke.

Other means may be employed for operating the horizontal knife without departing from the spirit of my invention.

To the front surface of the anvil is secured a roller, *k*, against which the outer surface of

the wedge *f* bears to hold it to its work while forcing the knife *e* into the edge of the bar.

In the operation of making blanks by my improved machine a bar of a predetermined width and thickness is heated and placed in the slot *i* of the anvil. The downstroke of the head B causes the wedge *f* to force the knife *e* into the edge of the bar D; and forms an incision, *l*, in that portion of the bar which afterward becomes the tang *m* of the blank E when severed from the bar. While this operation is being performed the knife *a* and the die *b* cut out the rectangular corner *n* (shown in dotted lines in Fig. 4) at the end of the bar.

The upstroke of the head B withdraws the knife *e* and leaves an opening in the bar. The bar is then turned and moved along in the slot *i*, when the next downstroke of the head B will drive the knife *e* into the bar on the side opposite to that in which the incision *l* was made by the former stroke, and simultaneously therewith the knife *a* and the die *b* will cut a complete shovel-blank from the bar, with its tang split and the socket for the handle formed. Each successive stroke of the machine after the first on each bar severs a complete blank ready for the reducing-rolls—a result hitherto never obtained. The bar is reversed after each operation.

By reference to Fig. 5 it will be seen that the incision *l* in the tang *m* does not extend quite to the side edges of the tang, but leaves a small uncut portion, *o o*, on each side. By this construction the blank can be rolled longitudinally in one direction without spreading or crossing the handle-straps formed by the tang. After the blank has been severed from the bar a little cinder is thrown into the incision *l*, to prevent the severed parts from adhering to each other in rolling the blank, and after the blank has been rolled out to its full dimensions the handle-straps are released by trimming the uncut portions from the blank. A clamping plate or bar (not shown) may be used across the upper surface of the anvil to hold the bar down in the groove *i*.

Other blanks than those used for making shovels can be manufactured in this manner with equal facility and dispatch, and instead of laying the bar on its side to make the in-

cision in its edges alternately the bar may be placed on one edge and the incision made in the opposite edge by a vertical knife, and the corner-pieces *n* may be cut out and the blank
5 severed from the bar by horizontal knives or cutters.

The machine herein described is claimed in my application Serial No. 268,523, and the blank as a new article of manufacture is claimed
10 in my application Serial No. 268,522.

Having thus fully described my invention, what I claim is—

The method of manufacturing blanks with split tangs, which consists in heating a bar of metal of a predetermined width and thickness, 15 forming incisions in the edge of the bar, and severing sections from the bar in the form of blanks, substantially as shown and described.

In testimony whereof I affix my signature in presence of two witnesses.

JAMES J. JOHNSTON.

Witnesses:

D. C. REINOHL,
D. P. COWL.