

(19)



(11)

EP 1 995 753 B1

(12)

EUROPEAN PATENT SPECIFICATION

(45) Date of publication and mention of the grant of the patent:
02.04.2014 Bulletin 2014/14

(51) Int Cl.:
H01H 25/06 (2006.01)

(21) Application number: **07010436.9**

(22) Date of filing: **25.05.2007**

(54) **Switching element for an appliance, especially for a domestic appliance**

Schaltelement für ein Gerät, insbesondere für ein Haushaltsgerät

Élément de commutation pour appareil, spécialement pour un appareil domestique

(84) Designated Contracting States:
AT BE BG CH CY CZ DE DK EE ES FI FR GB GR HU IE IS IT LI LT LU LV MC MT NL PL PT RO SE SI SK TR

(43) Date of publication of application:
26.11.2008 Bulletin 2008/48

(73) Proprietor: **Electrolux Home Products Corporation N.V.**
1130 Brussel (BE)

(72) Inventors:
• **Winkelmann, Klaus**
63688 Gedern (DE)

• **Meinberger, Thomas**
97262 Hausen (DE)

(74) Representative: **Baumgartl, Gerhard Willi et al**
Electrolux Dienstleistungs GmbH
Group Intellectual Property
90327 Nürnberg (DE)

(56) References cited:
EP-A1- 1 017 077 US-A1- 2004 154 910
US-A1- 2006 096 845

EP 1 995 753 B1

Note: Within nine months of the publication of the mention of the grant of the European patent in the European Patent Bulletin, any person may give notice to the European Patent Office of opposition to that patent, in accordance with the Implementing Regulations. Notice of opposition shall not be deemed to have been filed until the opposition fee has been paid. (Art. 99(1) European Patent Convention).

Description

[0001] The invention relates to a switching element for an appliance, especially for a domestic appliance, having in combination an adjustment element for adjusting an operation parameter of the appliance by rotating a disc around an axis of rotation and a switching element for switching an operation parameter of the appliance by pressing a pushbutton in the direction of the axis of rotation, wherein the pushbutton has a circular perimeter, wherein the pushbutton is arranged in a corresponding circular concentric reception in the adjustment element and wherein means are provided for preventing a rotational movement of the pushbutton relatively to the switching element around the axis of rotation.

[0002] Especially domestic appliances need often a switching element of the kind mentioned above. For example the temperature or intensity of a heating element of a domestic oven can be selected or adjusted by turning a disc to a definite angular position. After the respective position is reached a pushbutton can be pressed to e. g. activate the power supply. In many cases the pushbutton has an inscription which should not vary its position so that it is always legible without problems. So, it is desired that the pushbutton remains in a defined angular position even when the disc is turned.

[0003] On the other hand a good guidance is desired for the disc as well as for the pushbutton.

[0004] A switching element according to the kind mentioned above is known from US 2004/0154910 A1. Other solutions are known from US 2006/0096845 A1 and from EP 1 017 077 A1.

[0005] It is an object of the invention to improve a switching element of the kind mentioned above so that the referred advantages can be obtained. I. e. the pushbutton should always remain in a defined angular position. Furthermore, the pushbutton as well as the disc should be well guided when used. This should become possible in a cheap way and by using standard elements which are usually employed for appliances, especially for domestic appliances.

[0006] The solution of this object according to the invention is characterized in that the switching element has two concentric sleeves, wherein one sleeve is stationary and fixed to a carrier element of the switching element and one sleeve is rotatable and fixed with the disk, wherein the means for preventing a rotational movement of the pushbutton are at least one groove-like reception in the stationary sleeve and at least one protrusion at the switching element which extends into the groove-like reception or wherein the means for preventing a rotational movement of the pushbutton are at least one protrusion at the stationary sleeve and at least one groove-like reception in the switching element, wherein the protrusion extends into the groove-like reception, wherein the at least one groove-like reception and the at least one protrusion extends along the axis of rotation at or in the parts.

[0007] Preferably a plurality of groove-like receptions

and protrusions are arranged around the circumference of the parts.

[0008] The adjustment element can be connected to the rotatable sleeve by means of at least one protrusion and at least one groove-like reception in which the at least one protrusion extends.

[0009] The two concentric sleeves can be parts of an encoder.

[0010] The carrier element can be connected by connection means to a switch panel of the appliance. The disk can be connected with the adjustment element by means of a snap-on connection. Also, the pushbutton can be connected with the switching element by means of a snap-on connection.

[0011] The pushbutton can be held resiliently in an axial end position by means of a spring element; preferably, the spring element is a coil spring.

[0012] The switching element can be connected with a switch at the axial end being remote from the pushbutton.

[0013] In the drawings an embodiment of the invention is depicted.

FIG 1 shows a cross sectional side view through a switching element of a domestic oven and

FIG 2 shows the sectional view A-B according to FIG 1.

[0014] In the figures a switching element 1 of a domestic oven is shown by which an operation parameter of the domestic appliance can be adjusted and activated. For adjusting the parameter an adjustment element 2 is employed. The adjustment element 2 has a disk 3 which can be rotated around an axis of rotation 4. By doing so, the parameter is adjusted to a desired value, e. g. the intensity or power of a heating element of the domestic oven. On the other hand an operational parameter can be switched on and off by a switching element 5 which has a pushbutton 6.

[0015] As can be seen in the synopsis of FIG 1 and FIG 2 the pushbutton 6 has a circular perimeter. It is arranged in a corresponding circular concentric reception 7 in the adjustment element 2.

[0016] The switching element 5 is connected to a switch panel 14 of a control unit which is part of the appliance. More specifically, the switch panel 14 bears a carrier element 12 which is connected with the switch panel 14 by suitable means. In the embodiment according to FIG 1 connection means 13 are employed which function as spacers which not only fix the carrier element 12 to the switch panel 14 but also hold it in a fixed relative position to it. Also a screw connection can be employed as connection means.

[0017] The carrier element 12 bears a switch 16 and other electronic elements necessary to fulfil the desired function (which is not relevant for the invention in question). The switching element 5 is connected with the

switch 16 (no permanent connection). I. e. if the push-button 6 is pressed the switch 16 is activated. The push-button 6 is hold resiliently in an axial end position by means of a coil spring 15, i. e. the pushbutton 6 is pressed against the force of the coil spring 15.

[0018] The carrier element 12 also bears a pair of concentric sleeves 10 and 11, more specifically an inner stationary sleeve 10 and an outer rotatable sleeve 11. Both sleeves form a part of an encoder.

[0019] Provision is made that the disc 3 and the adjustment element 2 respectively are torque proof connected with the outer sleeve 11, so that a rotation of the disc 3 actuates the adjustment of an operation parameter. Also, provision is made that the pushbutton 6 and the switching element 5 respectively can be moved axially in the direction of the axis 4 but remains stationary with respect to the angular position.

[0020] For this the inner sleeve 10 has a plurality of groove-like receptions 8 (see FIG 2) and the switching element 5 has the same number of protrusions 9. The receptions 8 and the protrusions 9 are formed congruently so that the protrusions 9 extend fittingly into the receptions 8. The receptions 8 as well as the protrusions 9 extend in axial direction of the axis 4. Consequently, the switching element 5 can be moved in axial direction without the possibility that a rotational movement occurs between the switching element 5 and the sleeve 10. As the sleeve 10 is stationary a rotational movement of the pushbutton 6 is prevented. In general, the receptions 8 and the protrusions 9 form means for preventing a rotational movement between the parts.

[0021] On the other hand, also the outer sleeve 11 has a plurality of groove-like receptions and the adjusting element 2 has the same number of protrusions, which are formed congruently. The receptions as well as the protrusions extend also here in axial direction of the axis 4. Consequently, a torque-proof connection exists between the adjustment element 2 and the sleeve 11.

[0022] The invention proposal guarantees that a good guidance of the pushbutton 6 and the switching element 5 respectively is established. The pushbutton 6 is secured against a rotational movement. Also standard parts can be used for the suggested switching element.

[0023] On the switch panel 14 not only the switch 16 is arranged but also other relevant and necessary parts of the unit, especially the encoder formed by the sleeves 10 and 11 and other controller elements.

[0024] Preferably snap-on connections can be used where parts have to be connected. The arrangement can be covered by a glass panel 17. As the pushbutton 6 does not rotate it is easily possible to place an inscription on it which remains legible under all circumstances.

Reference Numerals

[0025]

1 Switching element

2	Adjustment element
3	Disc
4	Axis of rotation
5	Switching element
5	6 Pushbutton
7	Reception
8, 9	Means for preventing a rotational movement
8	Groove-like reception
9	Protrusion
10	10 Inner sleeve (stationary)
11	11 Outer sleeve (rotatable)
12	12 Carrier element
13	13 Connection means
14	14 Switch panel (sheet metal carrier element)
15	15 Spring element
16	16 Switch
17	17 Glass panel

20 Claims

1. Switching element (1) for an appliance, especially for a domestic appliance, having in combination an adjustment element (2) for adjusting an operation parameter of the appliance by rotating a disc (3) around an axis (4) of rotation and a switching element (5) for switching an operation parameter of the appliance by pressing a pushbutton (6) in the direction of the axis (4) of rotation, wherein the pushbutton (6) has a circular perimeter, wherein the pushbutton (6) is arranged in a corresponding circular concentric reception (7) in the adjustment element (2) and wherein means (8, 9) are provided for preventing a rotational movement of the pushbutton (6) relatively to the switching element (1) around the axis (4) of rotation,

characterized in that

the switching element has two concentric sleeves (10, 11), wherein one sleeve (10) is stationary and fixed to a carrier element (12) of the switching element (1) and one sleeve (11) is rotatable and fixed with the disk (3),

wherein the means for preventing a rotational movement of the pushbutton (6) are at least one groove-like reception (8) in the stationary sleeve (10) and at least one protrusion (9) at the switching element (5) which extends into the groove-like reception (8) or wherein the means for preventing a rotational movement of the pushbutton (6) are at least one protrusion at the stationary sleeve (10) and at least one groove-like reception in the switching element (5), wherein the protrusion extends into the groove-like reception, wherein the at least one groove-like reception (8) and the at least one protrusion (9) extend along the axis (4) of rotation at or in the parts (6, 10).

2. Switching element according to claim 1, **characterized in that** a plurality of groove-like receptions (8)

and protrusions (9) are arranged around the circumference of the parts (6, 10).

3. Switching element according to claims 1 or 2, **characterized in that** the adjustment element (2) is connected to the rotatable sleeve (11) by means of at least one protrusion and at least one groove-like reception in which the at least one protrusion extends.
4. Switching element according to at least one of claims 1 to 3, **characterized in that** the two concentric sleeves (10, 11) are parts of an encoder.
5. Switching element according to at least one of claims 1 to 4, **characterized in that** the carrier element (12) is connected by connection means (13) to a switch panel (14) of the appliance.
6. Switching element according to at least one of claims 1 to 5, **characterized in that** the disk (3) is connected with the adjustment element (2) by means of a snap-on connection.
7. Switching element according to at least one of claims 1 to 6, **characterized in that** the pushbutton (6) is connected with the switching element (5) by means of a snap-on connection.
8. Switching element according to at least one of claims 1 to 7, **characterized in that** the pushbutton (6) is held resiliently in an axial end position by means of a spring element (15).
9. Switching element according to claim 8, **characterized in that** the spring element (15) is a coil spring.
10. Switching element according to at least one of claims 1 to 9, **characterized in that** the switching element (5) is connected with a switch (16) at the axial end being remote from the pushbutton (6).

Patentansprüche

1. Schaltelement (1) für ein Gerät, insbesondere für ein Haushaltsgerät, das in Kombination ein Einstellelement (2) zum Einstellen eines Betriebsparameters des Geräts durch Drehen einer Scheibe (3) um eine Drehachse (4) und ein Schaltelement (5) zum Schalten eines Betriebsparameters des Geräts durch Drücken eines Druckknopfes (6) in Richtung der Drehachse (4) umfasst, wobei der Druckknopf (6) einen kreisförmigen Außenumfang aufweist, wobei der Druckknopf (6) in einer entsprechenden kreisförmigen, konzentrischen Vertiefung (7) im Einstellelement (2) angeordnet ist und wobei Mittel (8, 9) vor-

gesehen sind, um eine Drehbewegung des Druckknopfes (6) in Relation zum Schaltelement (1) um die Drehachse (4) zu vermeiden,

dadurch gekennzeichnet, dass

das Schaltelement zwei konzentrische Hülsen (10, 11) aufweist, wobei eine Hülse (10) stationär und an einem Trägerelement (12) des Schaltelements (1) befestigt ist und eine Hülse (11) drehbar und an der Scheibe (3) befestigt ist.

wobei die Mittel zum Verhindern einer Drehbewegung des Druckknopfes (6) wenigstens eine nutartige Vertiefung (8) in der stationären Hülse (10) und wenigstens ein Vorsprung (9) am Schaltelement (5), der sich in die nutartige Vertiefung (8) erstreckt, sind oder wobei die Mittel zum Verhindern einer Drehbewegung des Druckknopfes (6) mindestens ein Vorsprung an der stationären Hülse (10) und mindestens eine nutartige Vertiefung im Schaltelement (5) sind, wobei sich der Vorsprung in die nutartige Vertiefung erstreckt,

wobei sich die wenigstens eine nutartige Vertiefung (8) und der wenigstens eine Vorsprung (9) entlang der Drehachse (4) oder in den Teilen (6, 10) erstrecken.

2. Schaltelement gemäß Anspruch 1, **dadurch gekennzeichnet, dass** eine Mehrzahl nutartiger Vertiefungen (8) und Vorsprünge (9) um den Außenumfang der Teile (6, 10) angeordnet sind.
3. Schaltelement gemäß Anspruch 1 oder 2, **dadurch gekennzeichnet, dass** das Einstellelement (2) mit der drehbaren Hülse (11) durch wenigstens einen Vorsprung und wenigstens eine nutartige Vertiefung, in die sich wenigstens ein Vorsprung erstreckt, verbunden ist.
4. Schaltelement gemäß wenigstens einem der Ansprüche 1 bis 3, **dadurch gekennzeichnet, dass** die zwei konzentrischen Hülsen (10, 11) Teile einer Codiereinrichtung sind.
5. Schaltelement gemäß wenigstens einem der Ansprüche 1 bis 4, **dadurch gekennzeichnet, dass** das Trägerelement (12) durch Verbindungsmittel (13) mit einer Schalttafel (14) des Geräts verbunden ist.
6. Schaltelement gemäß wenigstens einem der Ansprüche 1 bis 5, **dadurch gekennzeichnet, dass** die Scheibe (3) mit dem Einstellelement (2) durch eine Schnappverbindung verbunden ist.
7. Schaltelement gemäß wenigstens einem der Ansprüche 1 bis 6, **dadurch gekennzeichnet, dass** der Druckknopf (6) mit dem Schaltelement (5) durch eine Aufschnappverbindung verbunden ist.

8. Schaltelement gemäß wenigstens einem der Ansprüche 1 bis 7, **dadurch gekennzeichnet, dass** der Druckknopf (6) durch ein Federelement (15) elastisch in einer axialen Endposition gehalten wird.
9. Schaltelement gemäß Anspruch 8, **dadurch gekennzeichnet, dass** das Federelement (15) eine Schraubenfeder ist.
10. Schaltelement gemäß wenigstens einem der Ansprüche 1 bis 9, **dadurch gekennzeichnet, dass** das Schaltelement (5) mit einem Schalter (16) an dem axialen Ende, das sich entfernt vom Druckknopf (6) befindet, verbunden ist.

Revendications

1. Élément de commutation (1) pour un appareil, spécialement pour un appareil domestique, ayant en combinaison un élément d'ajustement (2) pour ajuster un paramètre d'opération de l'appareil en faisant tourner un disque (3) autour d'un axe (4) de rotation et un élément de commutation (5) pour la commutation d'un paramètre d'opération de l'appareil en appuyant sur un bouton-poussoir (6) dans la direction de l'axe (4) de rotation, où le bouton-poussoir (6) a un périmètre circulaire, où le bouton poussoir (6) est agencé dans un logement de réception concentrique circulaire correspondant (7) dans l'élément d'ajustement (2), et où des moyens (8, 9) sont prévus pour prévenir un mouvement de rotation du bouton poussoir (6) relativement à l'élément de commutation (1) autour de l'axe (4) de rotation, **caractérisé en ce que** l'élément de commutation possède deux manchons concentriques (10, 11), où un manchon (10) est stationnaire et fixé à un élément porteur (12) de l'élément de commutation (1) et un manchon (11) est apte à tourner et est fixé avec le disque (3), où les moyens pour prévenir un mouvement de rotation du bouton poussoir (6) sont au moins un logement de réception semblable à une rainure (8) dans le manchon stationnaire (10) et au moins une saillie (9) à l'élément de commutation (5) qui s'étend dans le logement de réception semblable à une rainure (8), ou bien où les moyens pour prévenir un mouvement de rotation du bouton-poussoir (6) sont au moins une saillie au manchon stationnaire (10) et au moins un logement de réception semblable à une rainure dans l'élément de commutation (5), où la saillie s'étend dans le logement de réception semblable à une rainure, où le au moins un logement de réception semblable à une rainure (8) et au moins une saillie (9) précitée s'étendent le long de l'axe (4) de rotation à ou dans les parties (6, 10).
2. Élément de commutation selon la revendication 1, **caractérisé en ce qu'**une pluralité de logements de réception semblable à une rainure (8) et saillies (9) sont agencés autour de la circonférence des parties (6, 10).
3. Élément de commutation selon les revendications 1 ou 2, **caractérisé en ce que** l'élément d'ajustement (2) est connecté au manchon de rotation (11) par au moins une saillie et au moins un logement de réception semblable à une rainure dans lequel au moins une saillie précitée s'étend.
4. Élément de commutation selon au moins une des revendications 1 à 3, **caractérisé en ce que** les deux manchons concentriques (10, 11) sont des parties d'un codeur.
5. Élément de commutation selon au moins une des revendications 1 à 4, **caractérisé en ce que** l'élément porteur (12) est connecté par des moyens de connexion (13) à un tableau de commutation (14) de l'appareil.
6. Élément de commutation selon au moins une des revendications 1 à 5, **caractérisé en ce que** le disque (3) est connecté à l'élément d'ajustement (2) par une connexion à enclenchement.
7. Élément de commutation selon au moins une des revendications 1 à 6, **caractérisé en ce que** le bouton poussoir (6) est connecté à l'élément de commutation (5) au moyen d'une connexion à enclenchement.
8. Élément de commutation selon au moins une des revendications 1 à 7, **caractérisé en ce que** le bouton-poussoir (6) est maintenu avec résilience dans une position d'extrémité axiale au moyen d'un élément de ressort (15).
9. Élément de commutation selon la revendication 8, **caractérisé en ce que** l'élément de ressort (15) est un ressort hélicoïdal.
10. Élément de commutation selon au moins une des revendications 1 à 9, **caractérisé en ce que** l'élément de commutation (5) est connecté à un commutateur (16) à l'extrémité axiale éloignée du bouton-poussoir (6).

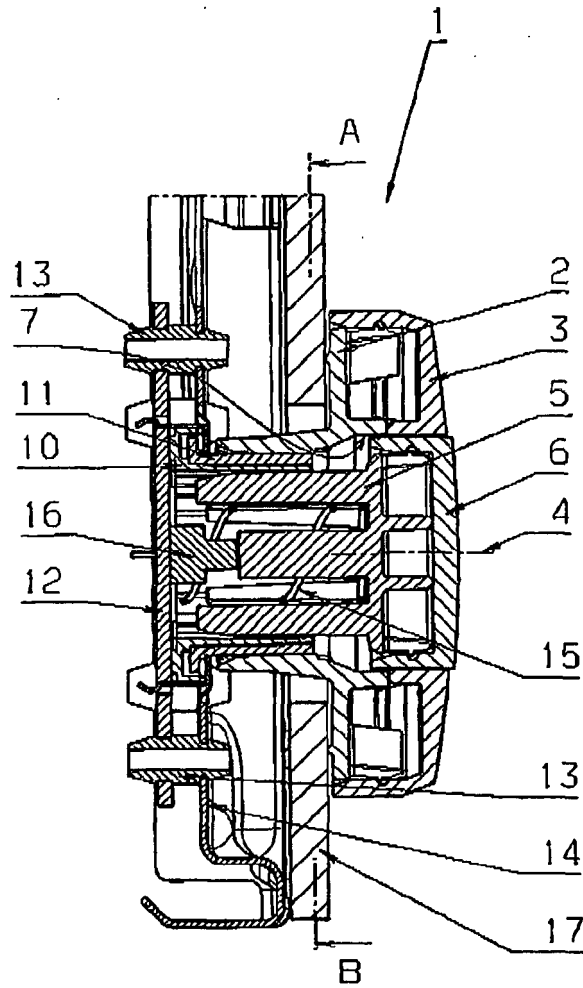

Fig. 1

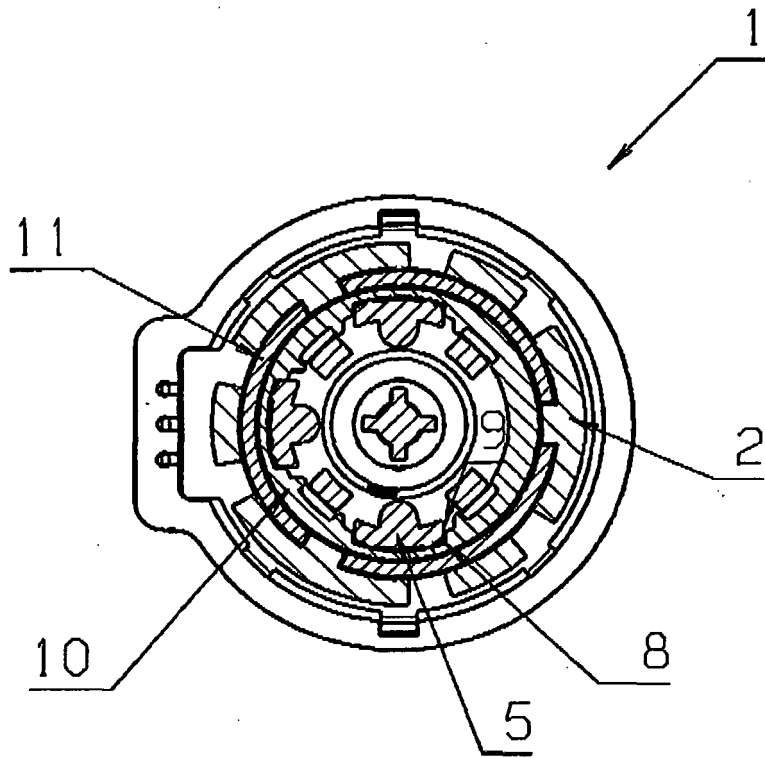

Fig. 2

REFERENCES CITED IN THE DESCRIPTION

This list of references cited by the applicant is for the reader's convenience only. It does not form part of the European patent document. Even though great care has been taken in compiling the references, errors or omissions cannot be excluded and the EPO disclaims all liability in this regard.

Patent documents cited in the description

- US 20040154910 A1 [0004]
- US 20060096845 A1 [0004]
- EP 1017077 A1 [0004]