

J. A. Millholland,

Brick Machine.

No. 111,076

Patented Jan. 17, 1871.

Fig. 3.

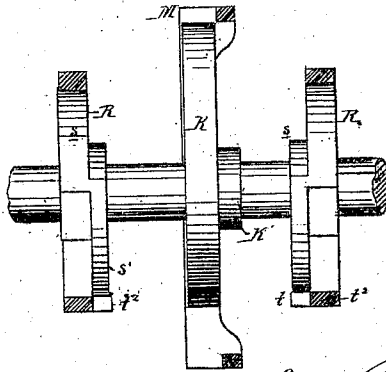
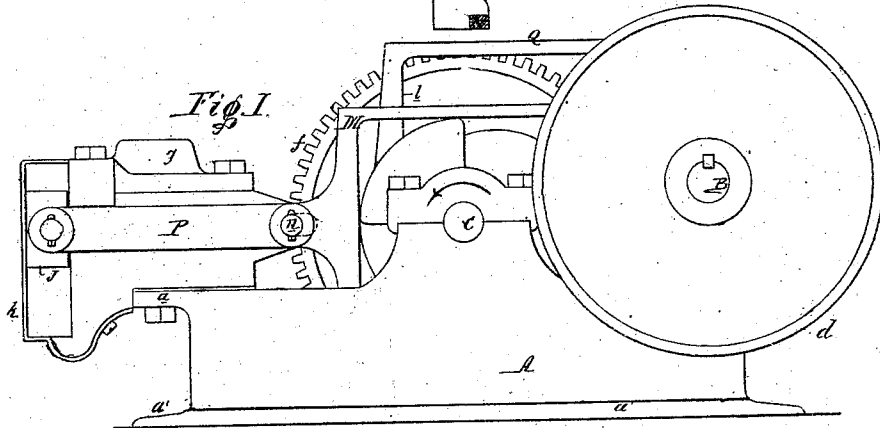
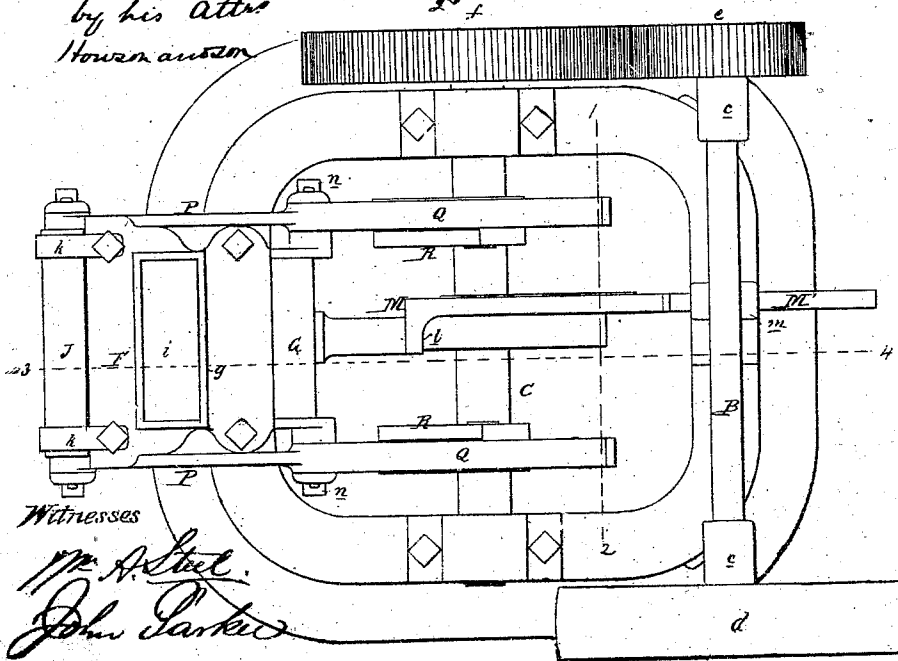

Fig. 1.



James A. Millholland
by his Attor
Hazen Anderson

Fig. 2.



Witnesses

Wm. A. Steel.
John Parker

J. A. Millholland,

Truck Machine.

No. 111,076.

Patented Jan. 17, 1871.

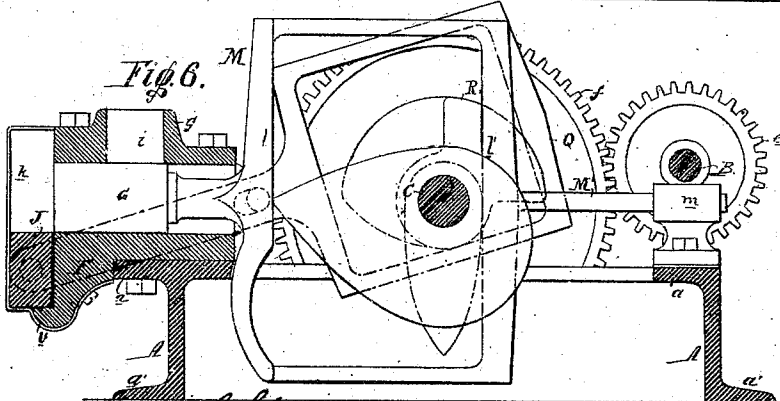
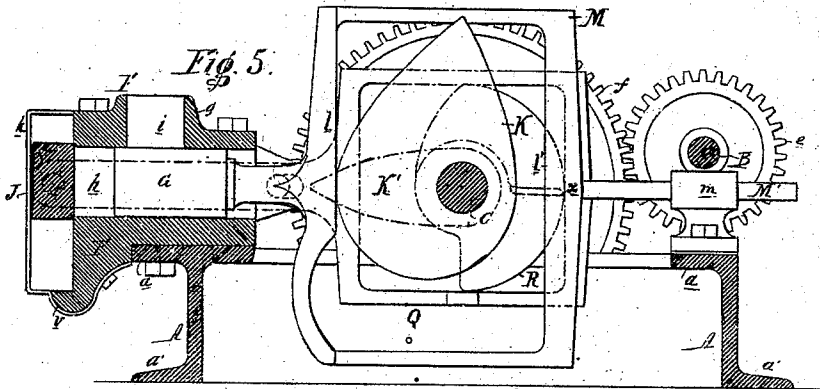
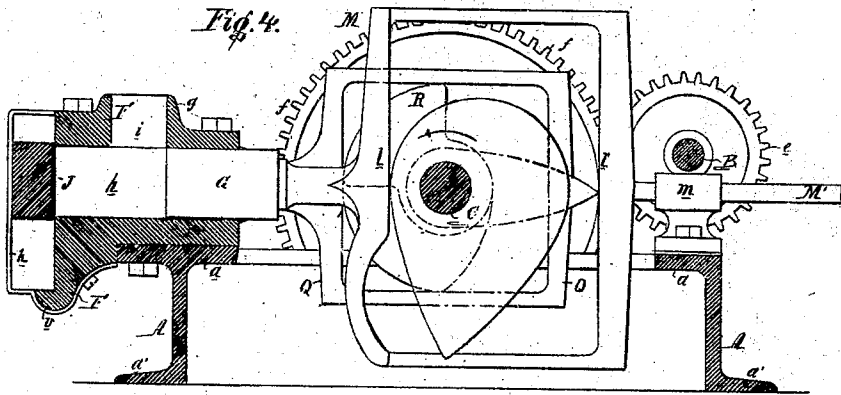

Witnesses
John Parker

James A. Millholland
 by his att^y *Horace Austin*

United States Patent Office.

JAMES ALLAIRE MILLHOLLAND, OF MOUNT SAVAGE, MARYLAND.

Letters Patent No. 111,076, dated January 17, 1871.

IMPROVEMENT IN BRICK-PRESSES.

The Schedule referred to in these Letters Patent and making part of the same.

I, JAMES ALLAIRE MILLHOLLAND, of Mount Savage, county of Alleghany, State of Maryland, have invented an Improved Brick-Press, of which the following is a specification.

Nature and Object of the Invention.

My invention consists of certain improvements in brick-presses, too fully described hereafter to need preliminary explanation, whereby the clay is rapidly and economically molded into bricks of uniform size and density.

Description of the Accompanying Drawing.

Figure 1, sheet 1, is a side elevation of my improved brick-press;

Figure 2, a plan view of the same;

Figure 3, a transverse section on the line 1 2, fig. 2, showing the cam-shaft; and

Figures 4, 5, and 6, sheet 2, are longitudinal sections on the line 3 4, fig. 2, showing the successive operations of the several parts of the machine.

General Description.

The bed-plate or frame A of the machine may be of any suitable form and construction. In the present instance it consists of a single box-like casting, rounded at the corners, and having flanges *a* and *a'* at both its upper and lower edges.

To this frame are secured bearings or standards *c c*, in which turns the driving-shaft B, the latter having at one end a driving-pulley, *d*, and at its opposite end a toothed pinion, *e*, which gears into a larger cog-wheel, *f*, of a cam-shaft, C, which also turns in suitable bearings on the frame of the machine.

The mold-box F is secured to one end of the frame, and has a longitudinal opening or passage, *h*, extending entirely through it, in which is arranged to slide a solid plunger, G, and with which communicates a vertical opening, *i*, formed in the lid or cap *g* of the box.

A transverse metal bar or cross-face, J, is arranged to slide between the outer end of the box F and guides *k k*, secured to the same, the said cross-face, when at the limit of its upward movement, entirely covering the end of the mold or passage *h*, while, when at the limit of its downward movement, it forms, with its upper edge, a continuation of the bottom of the said mold, (see fig. 6.)

The plunger G, above referred to, is operated by two cams K and K', placed side by side upon the cam-shaft, and operating alternately upon the faces *l* and *l'* of a yoke, M, which is fixed to or forms part

of the plunger-rod M', the latter sliding through and being steadied at its rear end by a guide, *n*, of the frame.

The cross-face J is hung to and operated by two vibrating rods or levers P P, which are slotted so as to have a limited sliding motion upon their fulcrums *n n*, at the opposite sides of the mold-box.

These vibrating levers have secured to or are formed at their inner ends into yokes Q Q, which are operated by double cams R R, on the cam-shaft, the portion *s* of each cam acting upon the faces *t t'* of its yoke, and the portion *s'* upon a lug, *t*, which projects from one side of the bottom of each yoke.

The operation of the machine is as follows:

A roughly-molded brick, or a mass of clay or other material from which a brick is to be made, is dropped through the opening *i* into the space *h*, in front of the plunger; when the latter and the several parts of the press are in the position shown in figs. 1 and 4, the cam-shaft turning in the direction indicated by the arrows.

The rounded portion of the cam K first strikes and turns upon the face *l* of the yoke *m*, thus gradually moving the plunger forward to the position shown in fig. 5, and compressing the brick between the same and the cross-face J, which is drawn up tightly against the end of the mold-box by the action of the portions *s* of the double cams R against the rear faces *t'* of the yokes Q.

After the brick has been thus compressed in the mold, the cam K, although continuing to turn, ceases for an instant to act upon the face *l* of the yoke, and the plunger remains stationary, the double cams R turning in the meantime to the position shown in fig. 5, and continuing to move until their portions *s'* have passed over the lugs *t'* of the yokes.

When this has occurred, the vibrating rods P will, partly owing to the weight of the cross-face J and partly to an upward blow given the yokes by the portions *s* of the double cams, turn upon their fulcrums to the inclined position shown in fig. 6, or until the cross-face J rests upon the foot *o* of the mold-box, with its upper edge flush with the bottom of the mold.

As soon as the cross-face has been thus depressed the cam K will again commence to act upon its yoke, and the plunger will be moved forward, as shown in fig. 6, until it has pushed the brick entirely out of the mold and onto the upper edge of the cross-face.

On the motion being continued, the cam K' will strike the rear face *l'* of the yoke *m*, and will draw the plunger back to its original position, fig. 4, and

at the same time the cross-face will also be raised and returned to its original position by the action of the portions s of the double cams upon the face t of the yokes Q.

The brick resting upon the top of the cross-face, when thus raised with the same, can either be removed by hand, or may remain upon the cross-piece during another operation of the machine, until it is pushed off by the next succeeding brick onto a traveling table or belt.

The above-described machine, although intended principally for compressing roughly-molded bricks of clay, can, it will be evident, be used for making fire-bricks, and building or other blocks, of any suitable material.

Claims.

1. The vibrating and sliding rods or levers P, ope-

rating as described, in combination with the cross-face J and operating mechanism, as and for the purpose set forth.

2. The yokes Q Q, at the inner ends of the said vibrating rods or levers, in combination with the double cams R R, for operating upon the yokes, substantially in the manner described.

In testimony whereof I have signed my name to this specification in the presence of two subscribing witnesses.

JAMES ALLAIRE MILLHOLLAND.

Witnesses:

ALONZO B. TURNER,
WM. J. WALKER.