

(19) World Intellectual Property Organization
International Bureau



(43) International Publication Date
5 April 2012 (05.04.2012)

(10) International Publication Number
WO 2012/041993 A1

(51) International Patent Classification:
F03D 3/06 (2006.01) *F03D 11/04* (2006.01)

Charles [FR/FR]; C/O Nenuphar, ABM Center, 128 rue du Faubourg de Douai, F-59000 Lille (FR).

(21) International Application Number:
PCT/EP2011/067054

(74) Agent: TAYLOR, Gillian Claire; Reddie & Grose LLP, 16 Theobalds Road, London Greater London WC1X 8PL (GB).

(22) International Filing Date:
29 September 2011 (29.09.2011)

(81) Designated States (unless otherwise indicated, for every kind of national protection available): AE, AG, AL, AM, AO, AT, AU, AZ, BA, BB, BG, BH, BR, BW, BY, BZ, CA, CH, CL, CN, CO, CR, CU, CZ, DE, DK, DM, DO, DZ, EC, EE, EG, ES, FI, GB, GD, GE, GH, GM, GT, HN, HR, HU, ID, IL, IN, IS, JP, KE, KG, KM, KN, KP, KR, KZ, LA, LC, LK, LR, LS, LT, LU, LY, MA, MD, ME, MG, MK, MN, MW, MX, MY, MZ, NA, NG, NI, NO, NZ, OM, PE, PG, PH, PL, PT, QA, RO, RS, RU, RW, SC, SD, SE, SG, SK, SL, SM, ST, SV, SY, TH, TJ, TM, TN, TR, TT, TZ, UA, UG, US, UZ, VC, VN, ZA, ZM, ZW.

(25) Filing Language: English

(26) Publication Language: English

(30) Priority Data:
1016391.3 29 September 2010 (29.09.2010) GB

(71) Applicant (for all designated States except US):
NENUPHAR [FR/FR]; ABM Center, 128 rue du Faubourg de Douai, F-59000 Lille (FR).

(72) Inventors; and

(75) Inventors/Applicants (for US only): SILVERT, Frederic [FR/FR]; C/O Nenuphar, ABM Center, 128 rue du Faubourg de Douai, F-59000 Lille (FR). SMADJA,

(84) Designated States (unless otherwise indicated, for every kind of regional protection available): ARIPO (BW, GH, GM, KE, LR, LS, MW, MZ, NA, RW, SD, SL, SZ, TZ,

[Continued on next page]

(54) Title: BLADE ATTACHMENT ARRANGEMENT FOR A VERTICAL AXIS WIND TURBINE

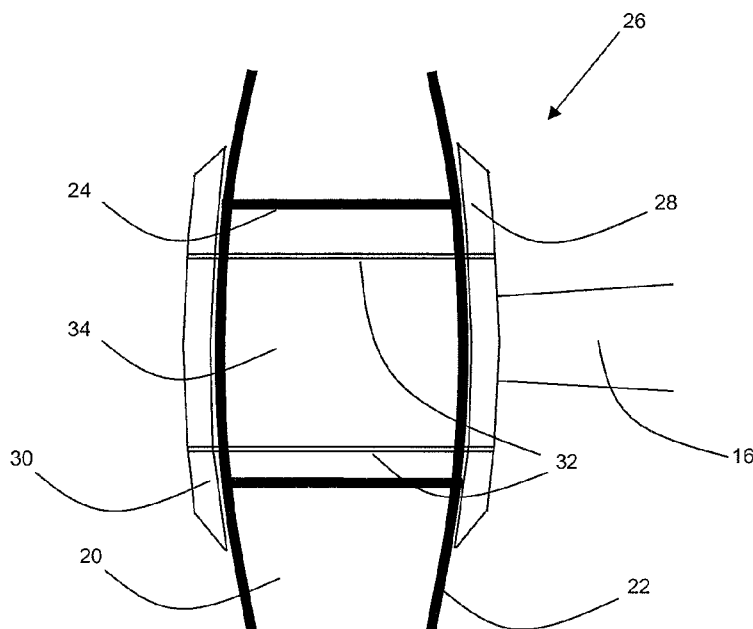

Figure 2

(57) Abstract: A blade attachment arrangement (26) for attaching a blade (14) to a support arm (16) of a vertical axis wind turbine (10) comprises: a pair of opposed attachment plates (28,30) for operatively clamping at least a part of the blade therebetween, such that the leading edge of the blade (14) is uncovered; and one or more fasteners (32) for connecting the opposed attachment plates (28,30) wherein the one or more fasteners (32) are operatively inserted through the part of the blade between the opposed attachment plates (28,30).

UG, ZM, ZW), Eurasian (AM, AZ, BY, KG, KZ, MD, RU, TJ, TM), European (AL, AT, BE, BG, CH, CY, CZ, DE, DK, EE, ES, FI, FR, GB, GR, HR, HU, IE, IS, IT, LT, LU, LV, MC, MK, MT, NL, NO, PL, PT, RO, RS, SE, SI, SK, SM, TR), OAPI (BF, BJ, CF, CG, CI, CM, GA, GN, GQ, GW, ML, MR, NE, SN, TD, TG). **Published:**
— *with international search report (Art. 21(3))*

BLADE ATTACHMENT ARRANGEMENT FOR A VERTICAL AXIS WIND TURBINE

The present invention relates to a novel blade attachment arrangement for a vertical axis wind turbine and to a vertical axis wind turbine incorporating such an arrangement.

5 Wind turbines and windmills have been used for centuries to harness the energy from the wind. Typically, conventional wind turbines have been of a horizontal axis type construction, with blades arranged around a horizontal shaft. However, vertical axis wind turbines (VAWTs) are also known. In wind turbines of a vertical axis construction, the blades are often arranged around a central, vertical mast and may be connected to the mast by
10 means of one or more support arms.

A number of different types of VAWT exist, each having a different arrangement and orientation of the blades. For example, in an H-type VAWT, the blades are typically arranged substantially vertically at an approximately constant distance from the central mast and the aerodynamic flow and associated angle of attack are almost constant along the
15 length of the blade. Unlike with horizontal axis wind turbines (HAWTs), it is therefore possible to use blades for an H-type VAWT which have a substantially constant cross-sectional shape and dimensions along the length of the blade. Other types of VAWT incorporate curved blades, for example, in an 'egg-beater' or troposkein formation, where the ends of each blade are typically mounted at the central mast.

20 Typically, the blades of a VAWT are formed of a composite material in order to provide a favourable strength to weight ratio. However, for a number of reasons relating to factors such as cost and manufacturing efficiency, the support arms used to mount the blades on the central mast are conventionally formed of a metallic material. The connection between structures made from composite materials and metallic structures often give rise to
25 problems due to the difference in the mechanical properties of the materials.

The connection of the blades to the support arms is also difficult to achieve whilst retaining the mechanical integrity of the composite blade structure in the region of the connection, in order to avoid premature fatigue failure of the blade. This is particularly the case for many conventional blades, which have a hollow structure that can easily be crushed
30 or damaged when the blades are clamped.

A variety of clamping arrangements for mounting blades onto a vertical axis wind turbine have been proposed. For example, US-A-2009/0068020 describes a clamping arrangement specifically adapted for hollow blades in which the blade is enclosed within two clamp plates which are bolted together at either side of the blade. Blade support blocks
35 must be incorporated within the hollow structure of the blade at the attachment point, to add

strength and stiffness to the blade such that the clamping pressure does not crush the blade shell.

In clamping arrangements such as that described in US-A-2009/0068020 the clamp plates fully enclose the blade in order to protect the blade structure from crushing. The plates are bolted together on either side of the blade in order to maintain mechanical integrity of the blade by avoiding having to drill holes in the blade for the bolts to pass through. However, these features inevitably lead to a clamping arrangement which is relatively bulky and which therefore has the potential to generate significant aerodynamic disturbances at the surface of the blade. Furthermore, since the clamp plates always cover the leading edge of the blade, the clamping arrangement also reduces the overall efficiency of the wind turbine.

It would therefore be desirable to provide an improved blade attachment arrangement for connecting the blades of a vertical axis wind turbine to the support arms extending from the central mast. In particular, it would be desirable if such an arrangement could be adapted so that the aerodynamic disturbances generated by the arrangement could be minimised and so that the efficiency of the wind turbine could be optimised.

According to the invention there is provided a vertical axis wind turbine comprising: a blade including a first blade portion comprising an outer shell formed of one or more layers of a composite material and providing an outer airfoil blade surface; and a support arm, one end of which is connected to the first blade portion by means of a blade attachment arrangement.

The blade attachment arrangement comprises a first attachment plate connected to a peripheral end of the support arm and in contact with the external surface of the outer shell of the first blade portion; a second attachment plate, opposed to the first attachment plate and arranged such that at least a part of the first blade portion is clamped between the first and second attachment plates; and one or more fasteners connected between the first and second attachment plates and passing through the part of the first blade portion between the first and second attachment plates.

The first blade portion may be an entire blade, or may be a module or segment of a modular blade, which is connected with other blade modules or segments to form a full blade, or may be a part of a transverse section of a blade or modular blade.

According to the present invention there is also provided a blade attachment arrangement for attaching a blade to a support arm of a vertical axis wind turbine, the arrangement comprising: a pair of opposed attachment plates for operatively clamping at least a part of the blade therebetween such that the leading edge of the blade is uncovered in the region of the blade attachment arrangement; and one or more fasteners for connecting

the attachment plates to each other, wherein the one or more fasteners are operatively inserted through the part of the blade between the opposed attachment plates.

The term "vertical axis wind turbine" (VAWT) is used to refer to a wind turbine for the conversion of wind energy to electrical energy in which one or more wind turbine blades are mounted for rotation around a central, vertical axis. This type of wind turbine would be known to the skilled person. Well known VAWT constructions include the H-type or "Darrieus" VAWT, which include vertical blades mounted around a central shaft. Other known types of VAWT incorporate a helical blade configuration, or a troposkein ("egg beater") blade configuration.

Vertical axis wind turbines of the present invention find application as onshore wind turbines for use on land, as well as offshore wind turbines. For example, in certain embodiments wind turbines according to the invention may be floating wind turbines for offshore use.

The term "peripheral end" refers to the free end of the support arm that is furthest from the central mast. The opposite end of the support arm will be attached to a central mast or other central supporting structure by suitable means.

Preferably, the first and second attachment plates are arranged such that the leading edge of the first blade portion is uncovered in the region of the blade attachment arrangement. The plates therefore have a minimal effect on the aerodynamic profile of the blades. This is important, since it is the leading edge of the blade which generates the majority of the aerodynamic lift and torque. The negative impact of the blade attachment arrangement on the efficiency of the wind turbine is therefore minimised compared to prior art arrangements in which the clamping plates enclose the leading edge of the blade.

Unlike in prior art clamping arrangements, the opposed attachment plates of the blade attachment arrangement of the present invention are connected together by means of one or more fasteners that pass at least part way through the thickness of the blade or blade portion, depending on the position of the plates.

Typically, the provision of holes in a vertical axis wind turbine blade in order to pass fasteners through the blade has been avoided, since in hollow blades the holes have an adverse effect on the mechanical integrity of the blade and it is therefore necessary to incorporate some sort of reinforcement structure within the blade. This not only complicates the arrangement but can also increase the weight of the blades. However, in the wind turbine of the present invention, the structure of the blade or blade portion is adapted to provide a built-in reinforcement structure that allows holes to pass through the blade without incorporating structural weaknesses.

The composite layers forming the outer shell of the blade provide reinforcement to the blade. In certain preferred embodiments of the invention, the blade comprises an inner core within the outer shell. Preferably, the inside of the blade is completely filled with the inner core material. The blade is therefore no longer hollow and the inner core provides a built-in reinforcement structure that allows holes to pass through the blade without incorporating structural weaknesses that may affect the lifetime of the blade. The inner core also prevents the crushing of the blades under the clamping force of the attachment plates. During use, the inner core additionally avoids local buckling of the outer shell of the blade during blade bending by permitting stress transfer from one side of the outer shell to the opposite side through the inner core and by preventing the blade shell from collapsing inwardly. A further advantage is that no additional reinforcement structure is required within the blade.

Alternatively or in addition to an inner core, the blade may be provided with an internal support structure in order to provide additional strength and reinforcement. For example, an internal support structure formed of composite and/or metallic materials may be provided, as described in more detail below. The internal support structure may be provided in the region of the blade attachment arrangement, or along substantially the full length of the blade.

The materials used to form the outer shell, the inner core and the internal support structure, where present, can advantageously be adapted to increase their reinforcement effect in the region of the blade attachment arrangement, as described in more detail below.

The use of fasteners passing through the blade to connect the first and second attachment plates enables the structure of the attachment plates to be adapted so that the plates cover a smaller surface area of the outer shell of the blade and are not required to pass around the leading edge or opposed trailing edge of the blade. Instead, when the attachment plates are provided externally on the blade, each plate can be positioned on the 'flat' surfaces of the blade or blade portion so that the impact of the plates on the aerodynamic properties of the blade is reduced. The term 'flat' is used here as a relative term to refer to the sides of the blade extending between the leading edge and trailing edge, which typically have a relatively low curvature. It is not intended to indicate that any part of the blade or blade portion is totally flat.

The reduction of the size of the attachment plates is also advantageous since the overall weight of the blade attachment arrangement can be minimised. The structure can also be simplified compared to prior art assemblies, since no additional, complex reinforcement inserts need to be incorporated within the blade. This in turn simplifies both

the manufacture of the blade attachment arrangement and the connection of the blade portion to the support arm during assembly.

5 Unlike with certain clamping assemblies of the prior art, which can only be used to connect the ends of the blades to support arms, the blade attachment arrangement of the present invention can be attached to the blade at any position along the length of the blade. For example, in certain preferred embodiments the blade attachment arrangement is at an intermediate position along the blade.

10 Preferably, in vertical axis wind turbines according to the present invention, the blade is connected to a central mast by means of a plurality of support arms which are spaced apart along the length of the blade. Each of the support arms may be connected to the blade or a portion of the blade using the blade attachment arrangement of the present invention. Alternatively, one or more of the support arms may be connected to the blade using a different type of arrangement, such that a combination of two or more different types of blade attachment arrangement are used to mount the blade on the central mast.

15 Preferably, in vertical axis wind turbines according to the invention in which each blade is supported by a plurality of support arms, the uppermost support arm is connected to the blade at a distance away from the upper tip end of the blade and the lowermost support arms is connected to the blade at a distance away from the lower tip end of the blade, such that the blade has free ends. Preferably, the distance between each of the uppermost and lowermost support arms and the closest tip end of the blade is between one quarter and one
20 half of the overall blade length and preferably around one third of the overall blade length.

Advantageously, the removal of the restriction to connect the uppermost and lowermost support arms at the tip ends of the blade enables greater freedom and flexibility in the positioning of the support arms. The position of the support arms can therefore be
25 adjusted for a particular wind turbine in order to minimise the level of stress in the blade and in the support arm and the bending moments acting on the blade and on the support arm during use. In addition, the positioning of the support arms away from the tip ends of the blade ensures that disruption of the aerodynamic performance of the blade tip is reduced.

The positioning of the uppermost support arm away from the upper, tip end of the
30 blade allows the overall height of the mast to be reduced, since the mast need only extend upwards to the height of the uppermost support arm and not to the upper tip end of the blade, as would be the case if the blade was supported at the tip end. This lowers the position of the centre of gravity of the wind turbine which may be beneficial for the stability of the turbine, in particular in the case of an offshore wind turbine, such as a floating wind
35 turbine.

Further, the positioning of the lowermost support arm away from the lower tip end of the blade allows the height of the base portion supporting the mast to be increased, since the mast needs only to extend downwards to the level of the lowermost support arm and not the lower tip end of the blade, as would be the case if the blade was supported at the tip end. This in turn enables the position of the bearings guiding the rotor of the turbine to be adjusted so that the cantilever on the rotor and any tilting moment on the bearings is reduced. In particular, the position of the upper bearings can be moved upwards relative to the base of the turbine. This adjustment in the position of the bearings will, in turn, optimise the dynamic stability of the turbine, which is important for both for onshore and offshore applications.

Preferably, the vertical axis wind turbines of the present invention comprise at least one additional blade, wherein the at least one additional blade can also be connected to one or more support arms using the blade attachment arrangement of the present invention, optionally in combination with other types of blade attachment arrangement. In one preferred embodiment of the invention, the wind turbine comprises three vertical blades forming an H-type vertical axis wind turbine, wherein the blades are preferably arranged approximately 120 degrees apart around a central mast.

In the vertical axis wind turbines of the present invention, the support arm may be connected to the blade such that the support arm is substantially perpendicular to the longitudinal axis of the blade. Preferably, the support arms are substantially horizontal in order to minimise the wake effect of the support arm and thereby optimise the efficiency of the wind turbine. Alternatively, the support arm may be connected to the blade at a different angle. The orientation of the first attachment plate, which is attached to the end of the support arm, can be adjusted depending on the angle required. Where additional support arms are incorporated, the support arms may be connected to the blade at the same angle, or at a different angle to each other.

In a first embodiment of the present invention, the first and second attachment plates of the blade attachment arrangement are provided on opposed sides of the first blade portion such that each attachment plate is in contact with the external surface of the outer shell and such that the one or more fasteners extend across the blade or blade portion between the opposed sides of the blade. In this embodiment, the opposed attachment plates are separated from each other in the transverse direction of the blade or blade portion and the entire blade cross section is clamped between the two, external attachment plates.

In a second embodiment of the present invention, the second attachment plate is provided internally within the inner part of the blade portion such that the one or more

fasteners extend part way through the blade, across the part of the blade portion between the first and second attachment plates.

In this embodiment, the second attachment plate takes the form of an internal insert, which is opposed to the first attachment plate but is provided within the inner part of the first blade portion rather than on the opposed external surface, as in the first embodiment. Only a portion of the blade cross section is therefore clamped between the two plates and the fasteners extend only part way through the blade cross section, from the external surface where the first attachment plate is in contact with the blade or blade portion, to the second plate within the inner part of the blade.

The second attachment plate may be provided at any position across the width of the first blade portion from the first attachment plate. In one example, the second attachment plate is provided approximately halfway across the width of the first blade portion from the first attachment plate, so that the plate is approximately in the centre of the inner part of the blade. Preferably, in embodiments in which the second attachment plate is provided internally within the blade, the blade is formed with an inner core, or an internal structure to support the attachment plate as described above.

In another example, the second attachment plate is provided within the inner part of the blade such that one surface of the plate is in contact with the inner surface of the outer shell of the blade. In this case, only the outer shell is clamped between the first and second attachment plates. Preferably, in this example, the surface of the second attachment plate in contact with the inner surface of the outer shell is adapted to substantially correspond to the inner surface of the outer shell so that stress levels in the outer shell are minimised and stress concentration phenomena are minimised.

This will typically be achieved by providing the second attachment plate with a curved surface that has a curvature that substantially matches that of the inner surface of the outer shell. Alternatively, the inner surface of the outer shell may be modified so that it can be matched with the surface of a plate having a shape that can easily be obtained with standard manufacturing processes. For example, the inner surface of the outer shell can be made flat and a flat plate can be used as the second attachment plate.

The form of the second attachment plate will typically be similar for both the first and second embodiments and will be described in more detail below.

As discussed above, one of the advantages of the present invention is that it is not necessary to incorporate complex reinforcement structures or inserts within the blade, since the existing integrated blade components can provide sufficient reinforcement to allow for the use of fasteners passing through the blade. The blade components can advantageously

be adapted in the region of the blade attachment arrangement to further improve the local reinforcement without affecting the structure or integrity of the blade.

Preferably, a high density internal core or a stiffened inner support structure is provided in the inner part of the blade in the region of the blade attachment arrangement.

5 An increased density of the inner core or a stiffened inner support structure in the region of the blade attachment arrangement helps to prevent any crushing of the blade during tightening of the fasteners connecting the first and second attachment plates. The high density or stiffened structure can conveniently be incorporated into the inner part of the blade during blade manufacture.

10 For example, in blades having an inner core (as described above), the inner core may be formed of a higher density material than the remainder of the inner core in the region of the blade attachment arrangement, to further improve the compressibility and/or stiffness characteristics of the inner core. In the case of a foam inner core, whilst the majority of the foam core will typically have a density of around 20 to 100 kg/m³, this is preferably replaced
15 with a region of foam having a density of between 100 and 400 kg/m³, more preferably between 150 and 250 kg/m³ in the region of the blade to which the blade attachment arrangement will be connected.

Alternatively or in addition to an inner core within the first blade portion, the blade outer shell may be reinforced locally by increasing the outer shell thickness. For example,
20 the blade may be provided with one or more additional layers or partial layers of composite material in the region of the blade attachment arrangement. Alternatively or in addition, some or all of the layers of composite material in the region of the blade attachment arrangement may be formed of a material having an increased strength and/or stiffness due to the material or the orientation of the fibres in the composite material. The increased
25 reinforcement within the composite material layers forming the outer shell helps to reduce the stress levels in the blade at the location of the holes for the fasteners. In one preferred embodiment, layers or pieces of multi-axial (preferably tri-axial) composite material are placed against the inner surface of the composite material layers that form the outer shell of the blade or blade portion.

30 The blade or blade portion may alternatively or additionally be provided with internal, reinforced rims, webs or other composite support structures which extend across the blade cross section between the inner surfaces of the outer shell, to provide additional reinforcement. For example, one or more rims may extend transversely across the blade, or longitudinally along the blade, substantially parallel to the blade axis, or both. These
35 internal reinforcements may be provided along a part or all of the length of the blade.

The inclusion of internal reinforcements helps to prevent any crushing of the blade between the attachment plates and to transmit the loads from one surface of the outer shell to the other in order to increase the blade stiffness and prevent shell local buckling phenomena. For example, additional rims can be added locally to avoid blade shell buckling in specific regions where the blade experiences local large deflections while bending. Additional support structures may be provided instead of an inner core, or in addition to an inner core.

The first and second attachment plates are preferably metallic plates but other types of materials may be suitable, provided sufficient strength can be achieved for the clamping purpose of the plates. The first and second plates may be made of the same material as each other or of different materials. For example, in one preferred embodiment of the present invention, the first attachment plate is made in metal to facilitate the fixing or fastening of the attachment plate to the blade support arm, whilst the second plate is made in composite material.

The first and second attachment plates may be formed in any suitable shape but are preferably relatively thin compared to the dimensions of the blade in order to minimise the aerodynamic disturbance of the airflow around the blade profile in the region of the blade attachment arrangement. Preferably, the first and second attachment plates are substantially parallel to each other and to the longitudinal axis of the first blade. Preferably, where the attachment plates are formed of metal, the average thickness of the attachment plates is between 5 mm and 20 mm, more preferably between 10 mm and 15 mm.

Preferably, the thickness of at least one of the attachment plates decreases towards the outer edges of the plate. The reduction of the thickness of the plates may be provided by a gradual reduction from the centre of the plate to the edges thereof. Alternatively, the plate may have a substantially constant thickness apart across the majority of its area, (including in the region accommodating the fasteners), apart from at the outer edges where the reduction of thickness is provided. For example, in one preferred embodiment of the invention, the outer edges of at least one of the attachment plates are bevelled.

The reduction of the thickness of the attachment plates at the edges further minimises the aerodynamic disturbance of the airflow around the blade profile, since there is a smoother transition between the external surface of the outer shell of the blade or blade portion and the attachment plate.

Where the second attachment plate is in the form of an internal insert supported within an inner core or an inner support structure, it is particularly preferred to reduce the thickness of the insert towards the outer edges so that the integration of the insert within the inner core does not generate high shear stresses or stress concentration phenomena.

At least one of the attachment plates may comprise a plurality of teeth or lugs extending from at least one edge of the plate or at least one edge which thickness decreases when moving outwardly from the centre of the plate to the edges thereof. Particularly preferably, at least one of the attachment plates is provided with teeth on two
5 opposed edges, or on all edges of the plate. The provision of the teeth is particularly preferred where the second attachment plate is in the form of an internal insert, since this advantageously improves the load distribution at the edges of the insert so that stress levels in the blade can be reduced in the blade attachment region.

In certain embodiments of the present invention, a recess may be provided on one or
10 both sides of the external surface of the outer shell, in which the first attachment plate and/or the second attachment plate are provided such that the attachment plate is integrated within the blade airfoil profile section. The outer surface of the attachment plate may itself form the blade airfoil surface together with the surrounding external surface of the outer shell. In this case, any gap between the attachment plate and the edges of the recess may be filled or
15 covered by any standard means in order to present a continuous aerodynamic shape in the region of the blade attachment.

Alternatively and preferably, the outer surface of the attachment plate may be inset or recessed from the external surface of the outer shell and an aerodynamic cover may be provided over the recess. The aerodynamic cover forms a substantially continuous airfoil
20 surface with the surrounding external surface of the outer shell.

The provision of one or both of the attachment plates within a recess on the external surface of the first blade portion helps to ensure aerodynamic continuity of the blade surface and reduces the drag and aerodynamic disturbance generated by the plate. This reduces the negative impact of the blade attachment arrangement on the efficiency of the wind
25 turbine.

One or both of the attachment plates may be provided in a recess, as described above. Preferably, in turbines and blade assemblies according to the first embodiment of the invention, at least the second attachment plate is provided within a recess, since this is where the greatest reduction in drag can be achieved.

30 Preferably, a layer of an adhesive is provided between at least one of the attachment plates and the area of the surface of the outer shell of the blade or blade portion with which the attachment plate is in contact. In the case of the first attachment plate, the layer of adhesive will be provided between the plate and the external surface of the outer shell, whilst in the case of the second attachment plate, the layer of adhesive may be provided
35 between the plate and the external or internal surface of the outer shell, depending upon the position of the second attachment plate.

Suitable adhesives would be known to the skilled person but preferably, a silicone type adhesive is used between the attachment plate and the outer surface of the blade outer shell. This type of adhesive is particularly advantageous since it is disposable, which allows the plates, and thus the blades, to be removed for maintenance or repair. Preferably, the layer of adhesive has a thickness of approximately 1 mm or less.

The adhesive fills any gaps between the inner surface of the attachment plates and the underlying external surface of the outer shell. The incorporation of an adhesive layer thereby improves the strength of the connection between the attachment plates and the blade. In addition, the adhesive layer makes the stress distribution at the interface between the attachment plate and the blade surface more even or homogenous and improves the load transfer from the blade to the attached supporting arm. This is important, since the aerodynamic power-generating torque from the blades must be transferred to the central mast through the support arm as efficiently as possible.

Furthermore, the layer of adhesive ensures that the blade attachment arrangement is watertight so that during use, water or moisture does not penetrate into the inner part of the blade through the holes for the fasteners.

The inner surface of the first attachment plate is preferably adapted to substantially correspond to the external surface of the blade or blade portion with which the first attachment plate is in contact, thereby improving the contact between the attachment plate and the blade surface. Similarly, in wind turbines or blade assemblies according to the first embodiment of the invention in which the second attachment plate is provided externally, the inner surface of the second attachment plate is also preferably adapted to substantially correspond to the external surface of the blade or blade portion. In both cases, this will typically be achieved by providing the attachment plates with a curved inner surface that has a curvature that substantially matches that of the external surface of the blade or blade portion.

In wind turbines or blade assemblies according to the second embodiment of the present invention in which the second attachment plate is provided internally and is in contact with the internal surface of the outer shell, the shapes of the contacting surfaces of either or both of the plate and the outer shell may be adapted to substantially correspond to one another, as described above.

The one or more fasteners connecting the first and second attachment plates preferably comprise one or more metal bolts which are inserted through holes in the blade and may be secured with nuts. Other types of mechanical fasteners may also be suitable and such fasteners would be well known to the skilled person.

The holes in the first blade portion into which the one or more fasteners of the blade attachment arrangement are inserted may be incorporated into the blade during the manufacturing or moulding process, or may be drilled or otherwise formed in an existing blade or blade portion. The holes may optionally be provided in the form of one or more
5 hollow tubes, which are incorporated into the blade and into which the fasteners are inserted. The blade may include a single hole for a fastener of the blade attachment arrangement, or a plurality of holes for a corresponding plurality of fasteners. The cross-sectional shape of the hole or holes and the size thereof will depend upon the shape and size of the fastener to be inserted into the blade.

10 In the present invention, the blade is typically formed of a combination of composite materials. The one or more layers of the outer shell are preferably formed of a composite material comprising reinforcement fibres, such as glass fibres, impregnated with a resin matrix, such as epoxy. Preferably, the outer layers are formed of pre-impregnated composite materials. Other suitable examples of composite materials include materials
15 integrating non pre-impregnated glass fibres, pre-impregnated or not carbon fibres and/or epoxy and polyester resins. Preferably, the outer shell is formed of between three and six layers of a composite material for blades having a length of between 10 m and 15 m, although this may be higher for larger blades. The number of layers in the outer shell may vary along the length of the blade or blade portion as well as possibly along the blade chord,
20 to account for the different stress and/or strain levels at different parts along the length of the blade or blade portion during use. This may be particularly advantageous in longer blades or blade portions.

As described above, the blade may incorporate an inner core, which has been wrapped or covered with one or more layers of a composite material forming an outer shell.
25 The inner core may be formed of any suitable material that provides sufficiently high compressibility characteristics for use in conjunction with the blade attachment arrangement.

Preferably, the inner core is formed of a foam material. Suitable materials for forming the inner core include polyurethane foam or any other polymer foam or material presenting similar density and compressibility ranges and ratios. The foam material may be obtained
30 from two monomer precursors, which form a foam upon mixing. In this case, the foaming mixture can be poured into a closed mould such that the foam takes the shape of the mould as it forms. Alternatively, the core may be assembled from pre-formed or machined foam blocks.

The inner core may comprise a single piece of core material, or may be formed of
35 multiple cores that have been compacted and glued together, for example, by the resin from the outer layers of composite material during the blade manufacturing process.

During manufacture of the blade, the layers of composite material are typically wrapped around the rigid, inner core material and the combined materials are placed in a mould and heated. During heating, the rigid core may expand to fill the mould, for example where a foam material is used, thereby compressing the outer layers of composite materials and forming the desired airfoil shape of the blade or blade portion. In addition, the outer layers of the composite materials cure and the resin within the layers infuses into the inner core to bond the outer layers and the core, as well as bonding any separate sections of the core that may be present.

Any additional reinforcement in the form of high density material, inner support structures, internal reinforcement rims, webs or composite support structures made in composite material, additional outer layers or outer layers of a different material may be incorporated into the blade during the manufacturing process.

Alternatively, blades of the present invention may be formed either by standard infusion moulding processes commonly used to manufacture wind turbine blades, or by a pultrusion method. Such methods advantageously enable an internal support structure, such as an arrangement of inner rims, to be incorporated into the blade structure in place of the inner core. In wind turbines according to the present invention in which additional blades or blade portions are incorporated, these will be formed of similar materials and using similar techniques to those described above in relation to the first blade portion.

Preferably, each blade of the wind turbines according to the invention has a substantially constant cross section along the length thereof, providing a substantially constant aerodynamic airfoil profile and chord. However, in certain embodiments it may be more appropriate for each blade or blade portion to have a varying cross section.

Each blade of wind turbines according to the invention may be formed as a single component, or may be formed of two or more connected blade modules, where the blade attachment arrangement connects one of the blade modules to the support arm.

The support arm and any additional support arms incorporated into the wind turbine of the present invention are preferably formed of a metallic material but may alternatively be formed of another suitable material, such as a composite material.

The number, dimensions, heights, angles relative to a horizontal plane and cross section of the support arms in the vertical axis wind turbines according to the invention can be varied in order to optimise the performance and efficiency of the turbine. For example, the projected surface area of the support arms in the wind direction can be minimised in order to reduce the undesirable drag of the support arms as they rotate during use.

The first attachment plate is mounted on the peripheral end of the support arm. The connection may be achieved by providing a mechanical attachment arrangement, such as a

clamp or a bolted arrangement, between the plate and the support arm. Alternatively, the first attachment plate may be provided as an integral part of the support arm or the support arm attachment structure. For example, where the support arm and the first attachment plate are both formed of metallic materials, the first attachment plate may advantageously be
5 welded to the support arm so that the plate and support arm are integral to each other. This avoids the need for a separate attachment arrangement whilst providing a robust and lightweight connection between the attachment plate and the support arm.

The invention will be further described, by way of example only, with reference to the following figures in which:

10 Figure 1 shows a schematic representation of an H-shaped vertical axis wind turbine according to the invention;

Figure 2 shows a schematic, partial transverse cross-sectional view of a blade attachment arrangement between a blade and a support arm in a wind turbine according to a first embodiment of the invention;

15 Figure 3 shows a schematic, partial transverse cross-sectional view of an alternative blade attachment arrangement between a blade and a support arm in a wind turbine according to a second embodiment of the invention; and

Figure 4 shows a schematic, partial transverse cross-sectional view of a modified blade attachment arrangement in a wind turbine according to a first embodiment of the
20 invention.

The wind turbine 10 shown schematically in Figure 1 is a vertical axis wind turbine comprising a central, rotating mast 12 and two vertical blades 14. The blades 14 are positioned opposite each other to provide an "H" configuration and each blade is connected to the central, rotating mast 12 by four, spaced apart support arms 16. The support arms 16
25 extend substantially horizontally from the central rotating mast and the blades are mounted vertically on the ends of the support arms. Each blade 14 is connected to each of the support arms 16 by a blade attachment arrangement 26, 36, 46 described in more detail below. The uppermost support arm is provided at the top of the mast 12 and the blades 14 extend a short distance above the mast 12.

30 During use, the incident wind causes the blades 14 to rotate about the central mast 12 in the direction shown by the arrow A in Figure 1 and the torque is transmitted to the central mast 12 through the support arms 16. The central mast 12 is mounted in a base portion 18 of the turbine which includes a generator (not shown). The rotation of the central mast 12 is transferred directly to the rotor of the generator in a known manner.

35 The blades 14 are each formed of an inner foam core 20 formed of a polyurethane foam and a number of overlying layers of a glass reinforced epoxy resin composite material

forming an outer shell 22. A pair of reinforcement rims 24 extend between opposed sides of the outer shell along the length of the blade 14. Each blade has a substantially constant cross section, which is shaped in the form of an aerodynamic 'teardrop' or airfoil profile, in the conventional manner. This cross section provides the blade with a rounded leading edge and an opposed trailing edge, and the leading edge and the trailing edge are connected by two 'flat' surfaces having a curvature and surface area which is significantly lower than that of the leading edge.

Figure 2 shows a partial, transverse cross section through the blade 14 and the blade attachment arrangement 26 at one of the points of connection between the blade 14 and a support arm 16 in a wind turbine according to the first embodiment of the invention described above. Similar blade attachment assemblies may be provided at the other points of connection, or alternatively, different blade attachment assemblies may be used.

The blade attachment arrangement 26 comprises a first attachment plate 28 which is attached to the peripheral end of the support arm 16. The support arm 16 and the first attachment plate 28 are both formed of a metallic material and the first attachment plate 28 is welded to the end of the support arm 16. The first attachment plate 28 is in contact with the external surface of the blade 14, on the flatter surface of the blade 14 which is positioned closest to the central mast 12.

A second attachment plate 30 is provided on the opposite side of the blade cross-section, in contact with the opposite flat surface of the blade which is furthest from the central mast 12. The second attachment plate 30 is identical to the first attachment plate 28 and is positioned such that the attachment plates are substantially parallel and opposed, with their inner surfaces facing inwardly towards the blade 14.

The first 28 and second 30 attachment plates are rectangular in shape and the outer edges of each plate are bevelled so that the thickness of the plate is reduced at the edges. The inner surfaces of both of the attachment plates are curved in shape, so that the inner surface of each plate substantially follows the external surface of the blade 14. This maximises the area of contact between each plate and the blade surface.

A pair of spaced apart bolt fasteners 32 extends between the first 28 and second 30 attachment plates, passing through holes that have been drilled through the blade 14. The bolt fasteners 32 are tightened so that the first 28 and second 30 attachment plates clamp the blade 14 between them.

In the region of the blade attachment arrangement 26, the inner foam core 20 is formed of a high density foam 34 between the pair of rims 24, which provides additional reinforcement to the blades. The outer shell 22 is also provided with additional layers of composite material compared to other parts of the blade, for reinforcement purposes.

Whilst Figure 2 shows only a partial cross section, it is clear that the attachment plates cover only a portion of the flatter surfaces of the blade and that the leading edge and the trailing edge are both fully uncovered.

Figure 3 shows a partial, transverse cross section through the blade 14 and the blade attachment arrangement 36 at one of the points of connection between the blade 14 and a support arm 16 in a wind turbine according to the second embodiment of the invention described above. Similar blade attachment assemblies may be provided at the other points of connection, or alternatively, different blade attachment assemblies may be used.

The blade attachment arrangement 36 comprises a first attachment plate 38 which is identical to that shown in Figure 2 and described above. However, in place of the second attachment plate 30 of the blade attachment arrangement shown in Figure 2, the blade attachment arrangement 36 of Figure 2 includes an internal insert 40. The internal insert 40 is similar in shape and construction to the first attachment plate 38 but is provided within the inner foam core 20 of the blade. The internal insert 40 and the first attachment plate 38 are substantially parallel and opposed to each other, with their inner surfaces facing inwardly towards each other.

The internal insert 40 does not have a shaped inner surface since in this case it is not contacting a shaped external or internal surface of the blade; however, the outer edges of the internal insert 40 are bevelled in the same way as the first attachment plate 38.

A pair of spaced apart bolt fasteners 42 extends between the first attachment plate 38 and the internal insert 40, passing through holes that have been drilled part way through the blade 14 to a position just beyond that of the internal insert. The bolt fasteners 42 are tightened so that the first attachment plate 38 and the internal insert 40 clamp a portion of the blade between them.

As in the embodiment shown in Figure 2, in the region of the blade attachment arrangement, the inner foam core 20 is formed of a high density foam 32 between the pair of rims 24, which provides additional reinforcement to the blades. The internal insert 40 is provided in this region of high density foam. The outer shell 22 is also provided with additional layers of composite material compared to other parts of the blade, for reinforcement purposes. Additional internal reinforcement rims, webs or structures (not shown) may also be integrated between the pair of rims 24 on one side or on both side of the internal insert 40.

Figure 4 shows a partial, transverse cross section through the blade 14 and a modified blade attachment arrangement 46 at one of the points of connection between the blade 14 and a support arm 16 in a wind turbine according to the first embodiment of the invention described above. Similar blade attachment assemblies may be provided at the

other points of connection, or alternatively, different blade attachment assemblies may be used.

The blade attachment arrangement 46 is similar to the arrangement 26 shown in Figure 2 except that in the arrangement 46 the second attachment plate 30 is provided
5 within a recess 48 in the external surface of the blade 14. The recess 48 corresponds approximately in size and shape to the second attachment plate 30 and has a depth that is slightly greater than the thickness of the plate 30 such that the outer surface of the plate 30 lies below the external surface of the outer shell in the region surrounding the recess. An aerodynamic cover 50 is secured over the recess 48 in order to maintain a substantially
10 continuous airfoil surface in combination with the surrounding external surfaces of the outer shell.

CLAIMS

1. A vertical axis wind turbine comprising:
 - a blade including a first blade portion comprising an outer shell formed of one or more layers of a composite material and providing an outer airfoil blade surface; and
 - 5 a support arm, one end of which is connected to the first blade portion of the blade by means of a blade attachment arrangement comprising:
 - a first attachment plate connected to the support arm and in contact with the external surface of the outer shell of the first blade portion;
 - 10 a second attachment plate, opposed to the first attachment plate and arranged such that at least a part of the first blade portion is clamped between the first and second attachment plates; and
 - one or more fasteners connected between the first and second attachment plates and passing through the part of the blade portion between the first and second attachment plates.
- 15 2. A vertical axis wind turbine according to claim 1 wherein the first and second attachment plates are arranged such that the leading edge of the first blade portion is uncovered in the region of the blade attachment arrangement.
- 20 3. A vertical axis wind turbine according to claim 1 or 2 wherein the first and second attachment plates are provided on opposed sides of the first blade portion such that each attachment plate is in contact with the external surface of the outer shell and such that the one or more fasteners extend across the first blade portion between the opposed sides thereof.
- 25 4. A vertical axis wind turbine according to claim 1 or 2 wherein the second attachment plate is provided internally within the first blade portion such that the one or more fasteners extend part way through the first blade portion, across the part of the blade portion between the first and second attachment plates.
- 30 5. A vertical axis wind turbine according to any preceding claim further comprising an internal support structure within the outer shell.
- 35 6. A vertical axis wind turbine according to any preceding claim wherein the blade comprises an inner foam core.

7. A vertical axis wind turbine according to claim 6 wherein in the region of the blade attachment arrangement, the inner foam core comprises higher density material than the remainder of the inner foam core.
- 5 8. A vertical axis wind turbine according to claim 7 wherein in the region of the blade attachment arrangement the density of the foam in the inner foam core is at least 100 kg/m³, preferably at least 150 kg/m³.
9. A vertical axis wind turbine according to any of claims 5 to 8 wherein in the region of
10 the blade attachment arrangement the first blade portion comprises additional internal reinforcement rims, webs or support structures made of composite material, extending at least part way across the blade.
10. A vertical axis wind turbine according to any preceding claim wherein in the region of
15 the blade attachment arrangement the first blade portion comprises one or more additional outer layers of composite material.
11. A vertical axis wind turbine according to any preceding claim wherein the thickness of
at least one of the attachment plates decreases towards the outer edges of the plate.
20
12. A vertical axis wind turbine according to any preceding claim wherein at least one of
the attachment plates comprises a plurality of teeth extending from at least one edge of the
plate.
- 25 13. A vertical axis wind turbine according to any preceding claim wherein at least one of
the attachment plates is provided within a recess in the external surface of the first blade.
14. A vertical axis wind turbine according to any preceding claim wherein a layer of an
adhesive is provided between at least one of attachment plates and the area of the surface
30 of the outer shell of the blade portion with which the attachment plate is in contact.
15. A vertical axis wind turbine according to any preceding claim wherein the inner
surface of at least one of the attachment plates is adapted to substantially correspond to the
surface of the outer shell of the blade portion with which the attachment plate is in contact.

16. A vertical axis wind turbine according to any preceding claim wherein the first attachment plate is integral to the support arm.

17. A vertical axis wind turbine comprising one or more additional support arms
5 connected to the blade at spaced apart positions along the length of the blade, wherein the one or more additional support arms are connected to the blade by means additional blade attachment arrangements.

18. A vertical axis wind turbine according to claim 17 wherein the uppermost support arm
10 and the lowermost support arm are connected to the blade at intermediate positions along the blade, away from the tip ends of the blade.

19. A blade attachment arrangement for attaching a blade to a support arm of a vertical axis wind turbine, the arrangement comprising:

15 a pair of opposed attachment plates for operatively clamping at least a part of the blade therebetween, such that the leading edge of the blade is uncovered; and

one or more fasteners for connecting opposed attachment plates wherein the one or more fasteners are operatively inserted through the part of the blade between the opposed attachment plates.

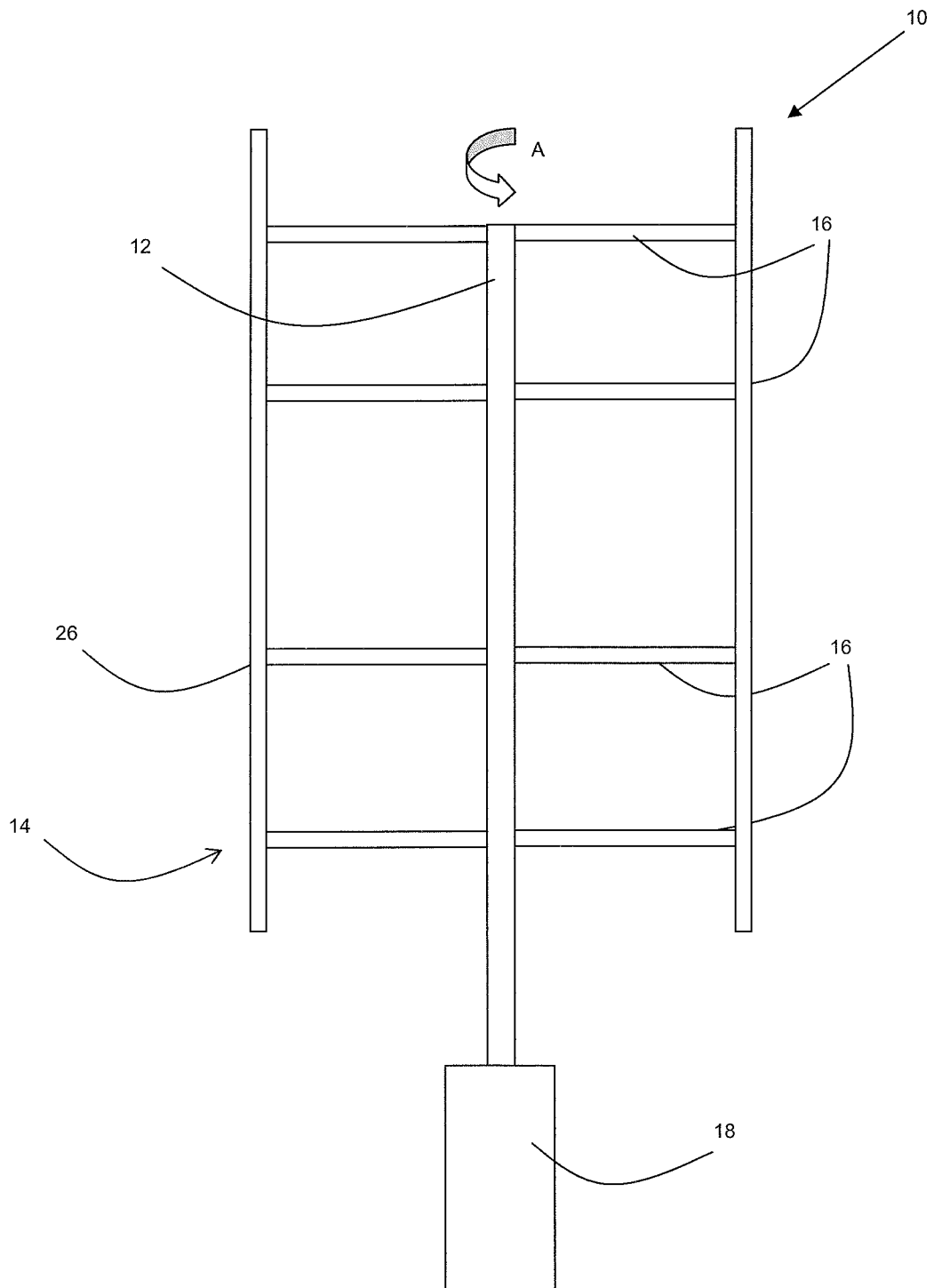

Figure 1

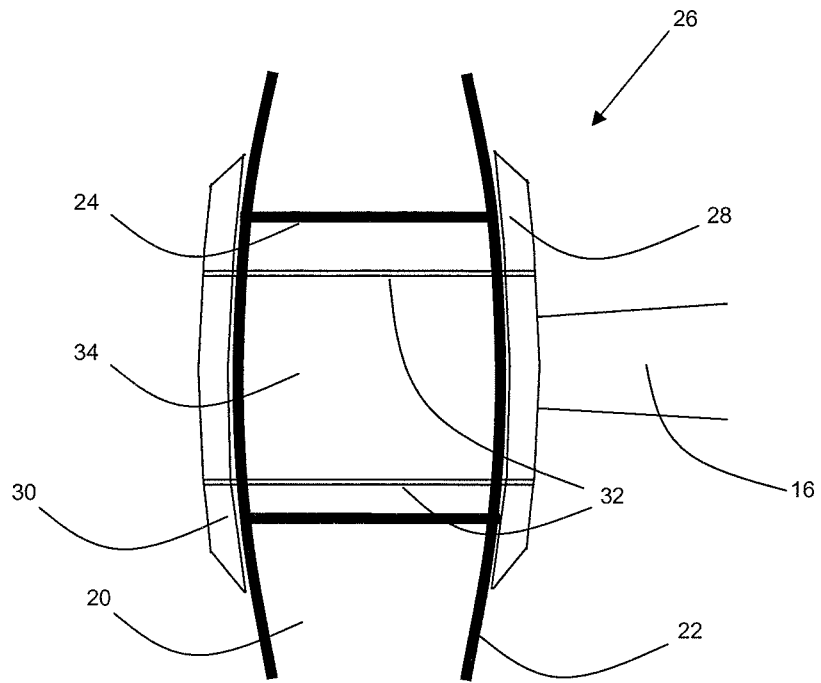

Figure 2

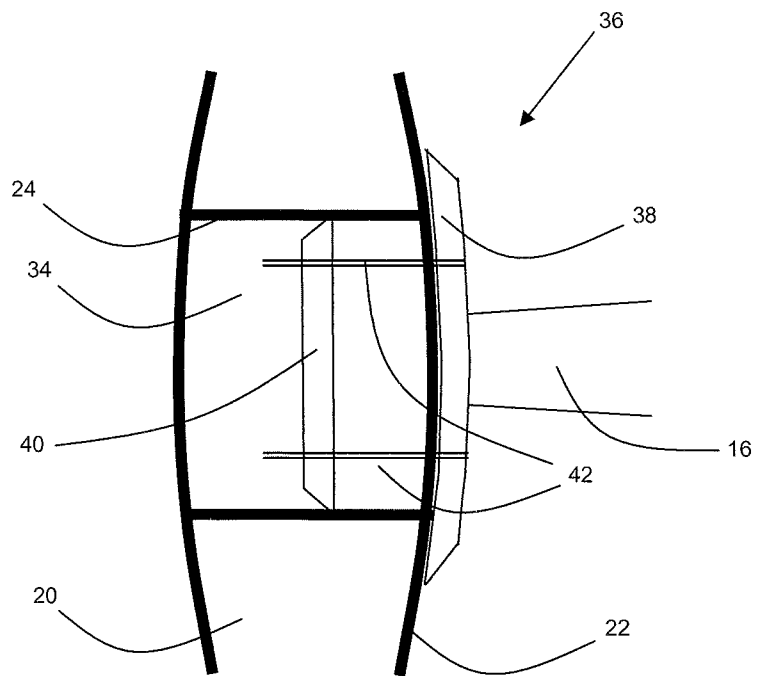

Figure 3

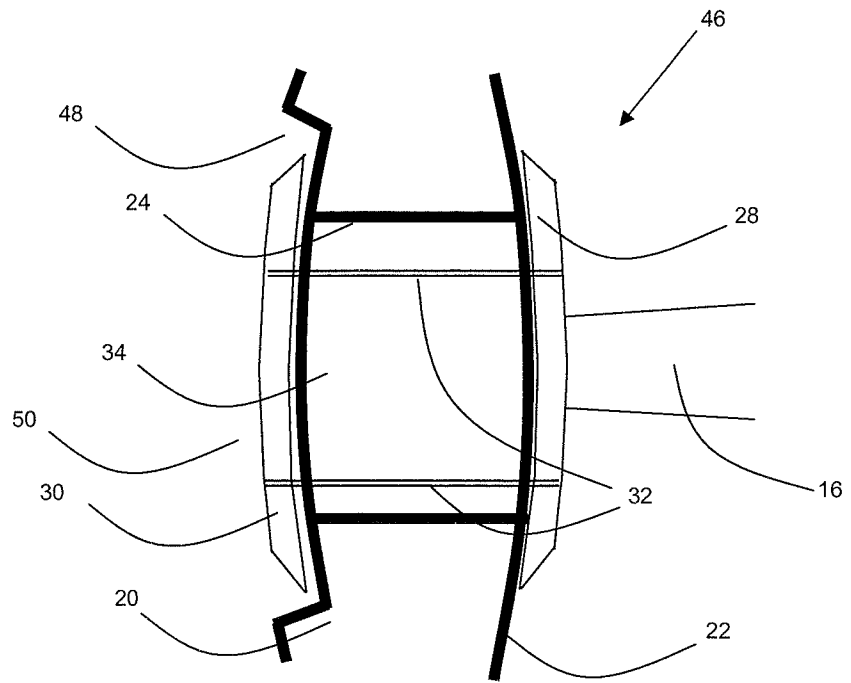

Figure 4

INTERNATIONAL SEARCH REPORT

International application No
PCT/EP2011/067054

A. CLASSIFICATION OF SUBJECT MATTER
 INV. F03D3/06 F03D11/04
 ADD.
 According to International Patent Classification (IPC) or to both national classification and IPC

B. FIELDS SEARCHED
 Minimum documentation searched (classification system followed by classification symbols)
 F03D

Documentation searched other than minimum documentation to the extent that such documents are included in the fields searched

Electronic data base consulted during the international search (name of data base and, where practical, search terms used)
 EPO-Internal

C. DOCUMENTS CONSIDERED TO BE RELEVANT

Category*	Citation of document, with indication, where appropriate, of the relevant passages	Relevant to claim No.
X A	WO 2008/035963 A2 (ECONCERN B V [NL]; SCHAAP ANTONIUS BERNARDUS [NL]) 27 March 2008 (2008-03-27) page 3, line 12 - line 14 page 7, line 8 - line 33 figure 1	1,2, 5-10,12, 14-19 3,4,11, 13
X A	----- US 2009/068020 A1 (BARNES ROBERT JEFFREY [US]) 12 March 2009 (2009-03-12) cited in the application paragraphs [0006], [0020], [0023] figure 1 ----- -/--	1,3, 5-10,12, 14-16, 18,19 2,4,11, 13,17

Further documents are listed in the continuation of Box C.

See patent family annex.

* Special categories of cited documents :

<p>"A" document defining the general state of the art which is not considered to be of particular relevance</p> <p>"E" earlier document but published on or after the international filing date</p> <p>"L" document which may throw doubts on priority claim(s) or which is cited to establish the publication date of another citation or other special reason (as specified)</p> <p>"O" document referring to an oral disclosure, use, exhibition or other means</p> <p>"P" document published prior to the international filing date but later than the priority date claimed</p>	<p>"T" later document published after the international filing date or priority date and not in conflict with the application but cited to understand the principle or theory underlying the invention</p> <p>"X" document of particular relevance; the claimed invention cannot be considered novel or cannot be considered to involve an inventive step when the document is taken alone</p> <p>"Y" document of particular relevance; the claimed invention cannot be considered to involve an inventive step when the document is combined with one or more other such documents, such combination being obvious to a person skilled in the art.</p> <p>"&" document member of the same patent family</p>
--	--

Date of the actual completion of the international search 9 January 2012	Date of mailing of the international search report 20/01/2012
---	--

Name and mailing address of the ISA/ European Patent Office, P.B. 5818 Patentlaan 2 NL - 2280 HV Rijswijk Tel. (+31-70) 340-2040, Fax: (+31-70) 340-3016	Authorized officer Lux, Ralph
--	--------------------------------------

INTERNATIONAL SEARCH REPORT

International application No
PCT/EP2011/067054

C(Continuation). DOCUMENTS CONSIDERED TO BE RELEVANT		
Category*	Citation of document, with indication, where appropriate, of the relevant passages	Relevant to claim No.
X	DE 20 2007 010873 U1 (FIBER TECH PRODUCTS GMBH [DE]; HEOS ENERGY GMBH [DE]) 4 October 2007 (2007-10-04) paragraphs [0001], [0013] figures 1,6,7 -----	1-19
X A	EP 1 746 286 A1 (INTELLECTUAL PROPERTY BANK [JP]) 24 January 2007 (2007-01-24) paragraphs [0001], [0056], [0057] figures 2,7,8,9 -----	1-10, 12-19 11
A	EP 2 177 752 A1 (GARCIA CASTRO FRANCISCO JAVIER [ES]; MANSO GARCIA JUAN JOSE [ES]) 21 April 2010 (2010-04-21) paragraphs [0001], [0002] -----	1-19

INTERNATIONAL SEARCH REPORT

Information on patent family members

International application No

PCT/EP2011/067054

Patent document cited in search report	Publication date	Patent family member(s)	Publication date
WO 2008035963	A2	27-03-2008	
		AU 2007297921 A1	27-03-2008
		CA 2664078 A1	27-03-2008
		CN 101517226 A	26-08-2009
		EP 2064443 A2	03-06-2009
		JP 2010504468 A	12-02-2010
		NL 1032555 C2	25-03-2008
		NZ 575398 A	24-12-2010
		US 2010086406 A1	08-04-2010
		WO 2008035963 A2	27-03-2008

US 2009068020	A1	12-03-2009	NONE

DE 202007010873	U1	04-10-2007	
		DE 202007010873 U1	04-10-2007
		EP 2028367 A1	25-02-2009

EP 1746286	A1	24-01-2007	
		CN 1954147 A	25-04-2007
		EP 1746286 A1	24-01-2007
		US 2007231139 A1	04-10-2007
		WO 2005111415 A1	24-11-2005

EP 2177752	A1	21-04-2010	
		CA 2694049 A1	22-01-2009
		CN 101802391 A	11-08-2010
		EP 2177752 A1	21-04-2010
		ES 2319152 A1	04-05-2009
		ES 2319154 A1	04-05-2009
		KR 20100045973 A	04-05-2010
		US 2010180439 A1	22-07-2010
