



INTERNATIONAL APPLICATION PUBLISHED UNDER THE PATENT COOPERATION TREATY (PCT)

<p>(51) International Patent Classification⁶ : H04J 3/16, 3/12, 3/14</p>	<p>A1</p>	<p>(11) International Publication Number: WO 95/05710</p> <p>(43) International Publication Date: 23 February 1995 (23.02.95)</p>
<p>(21) International Application Number: PCT/US94/06632</p> <p>(22) International Filing Date: 10 June 1994 (10.06.94)</p> <p>(30) Priority Data: 08/108,338 18 August 1993 (18.08.93) US</p> <p>(60) Parent Application or Grant (63) Related by Continuation US 08/108,338 (CIP) Filed on 18 August 1993 (18.08.93)</p> <p>(71) Applicant (for all designated States except US): SWL INC. [US/US]; 1900 Gallows Road, Vienna, VA 22182 (US).</p> <p>(72) Inventors; and (75) Inventors/Applicants (for US only): KIGHT, William, D. [US/US]; 3045 Patuxent Overlook Ct., Ellicott City, MD 21042 (US). PFISTER, Robert, E. [US/US]; 14564 Black Ankle Road, Mount Airy, MD 21771 (US).</p> <p>(74) Agents: TURNER, John, B. et al.; Finnegan, Henderson, Farabow, Garrett & Dunner, 1300 I Street, N.W., Washington, DC 20005-3315 (US).</p>		<p>(81) Designated States: AM, AT, AU, BB, BG, BR, BY, CA, CH, CN, CZ, DE, DK, ES, FI, GB, GE, HU, JP, KE, KG, KP, KR, KZ, LK, LU, LV, MD, MG, MN, MW, NL, NO, NZ, PL, PT, RO, RU, SD, SE, SI, SK, TJ, TT, UA, US, UZ, VN, European patent (AT, BE, CH, DE, DK, ES, FR, GB, GR, IE, IT, LU, MC, NL, PT, SE), OAPI patent (BF, BJ, CF, CG, CI, CM, GA, GN, ML, MR, NE, SN, TD, TG).</p> <p>Published With international search report.</p>

(54) Title: METHOD AND APPARATUS FOR THE MONITORING AND DEMARCATON OF SYNCHRONOUS OPTICAL NETWORK

(57) Abstract

A method and apparatus for establishing an intelligent demarcation between facility and terminal segments of asynchronous optical network. Network management information contained with the overhead structure of the synchronous optical network signal is extracted and manipulated in accordance with a predetermined user specification; overhead data may be translated, terminated, or passed unaltered as required. Overhead processing towards the facility and terminal segments need not be symmetrical. Payload information is passed unaltered although future provisions for encrypting payload data exist. Full performance monitoring is supported along with a built-in-test and diagnostic capability. The device may be both locally and remotely controlled and monitored. Remote control is implemented via the overhead information contained within the synchronous optical network signal.

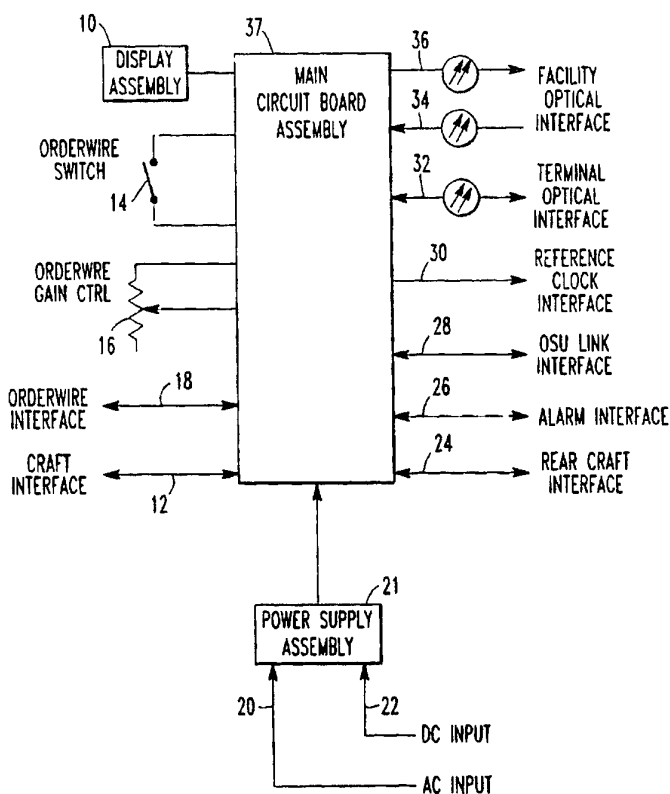

FOR THE PURPOSES OF INFORMATION ONLY

Codes used to identify States party to the PCT on the front pages of pamphlets publishing international applications under the PCT.

AT	Austria	GB	United Kingdom	MR	Mauritania
AU	Australia	GE	Georgia	MW	Malawi
BB	Barbados	GN	Guinea	NE	Niger
BE	Belgium	GR	Greece	NL	Netherlands
BF	Burkina Faso	HU	Hungary	NO	Norway
BG	Bulgaria	IE	Ireland	NZ	New Zealand
BJ	Benin	IT	Italy	PL	Poland
BR	Brazil	JP	Japan	PT	Portugal
BY	Belarus	KE	Kenya	RO	Romania
CA	Canada	KG	Kyrgystan	RU	Russian Federation
CF	Central African Republic	KP	Democratic People's Republic of Korea	SD	Sudan
CG	Congo	KR	Republic of Korea	SE	Sweden
CH	Switzerland	KZ	Kazakhstan	SI	Slovenia
CI	Côte d'Ivoire	LI	Liechtenstein	SK	Slovakia
CM	Cameroon	LK	Sri Lanka	SN	Senegal
CN	China	LU	Luxembourg	TD	Chad
CS	Czechoslovakia	LV	Latvia	TG	Togo
CZ	Czech Republic	MC	Monaco	TJ	Tajikistan
DE	Germany	MD	Republic of Moldova	TT	Trinidad and Tobago
DK	Denmark	MG	Madagascar	UA	Ukraine
ES	Spain	ML	Mali	US	United States of America
FI	Finland	MN	Mongolia	UZ	Uzbekistan
FR	France			VN	Viet Nam
GA	Gabon				

- 1 -

DescriptionMethod and Apparatus for the Monitoring and Demarcation of Synchronous optical NetworkTechnical Field

This invention relates to synchronous fiber optic telecommunication networks, specifically to the demarcation and performance monitoring of such networks at critical interfaces between public and private network entities.

Background Art

Fiber Optic networks have been in existence for some time now. The original fiber optic networks however typically employed proprietary asynchronous multiplexing schemes and interoperation between unrelated network elements was generally not possible. As fiber optic networks became more prevalent the need to efficiently connect fiber optic network segments directly at the optical level has become more critical.

The Synchronous Optical Network (SONET) standards were developed by the telecommunications industry to overcome the limitations of proprietary asynchronous schemes. SONET standards define an open network architecture that allows true multi-vendor interoperability.

An essential element of the SONET standard signal structure is a transport overhead data structure that supports enhanced network performance monitoring and network operations. The transport overhead contains among other things: parity information, protection switching control bytes, payload pointer and control bytes, a user data channel, local and express orderwire channels, and two data communication channels.

The two data communication channels are actually independent packet data networks designed to support Network Operations and Support Systems. Network Operations and Support Systems are the management tools used by telecommunication service providers to control and monitor the various elements present on their networks. Using the CCITT Q.921 LAPD protocol, which is very similar to the ANSI

- 2 -

X.25 protocol, it is possible for any device on the network to access and control any other device via the SONET data communication channels.

It was the intent of the SONET standards committees to develop a ubiquitous and homogenous fiber optic network whereby any element of the network could fully interoperate with any other element in the network. Manufacturers of SONET switching systems and SONET multiplexers have been staging multi-vendor demonstrations with an emphasis on interoperability at the fiber optic level.

The SONET standards however do not adequately reflect the political nature of the SONET network. Whereas SONET strives towards universal access and interoperability there are operational factors that force network operators to segment and isolate portions of the network. This situation can occur when two different service providers must interface with each other, or when a public service provider must extend service to a private customer premise.

For obvious reasons relating to network security, service providers need to restrict outside access to internal network operations. The data communications channels contained within the SONET transport overhead, designed to be open network management interfaces, represent a potential weak spot in the network security system.

Presently, SONET network segments are typically isolated at the boundaries between service providers by using back-to-back multiplexers; only the constituent channel data is passed between network segments and the SONET transport overhead functions are removed entirely. This type of interface defeats the open architecture of the network but must be maintained as a well defined demarcation point between network segments.

When extending SONET services to a private customer premise, a public service provider must rely upon the limited network security features supported by the transmission equipment on either end of the fiber optic span to protect the public network operations systems from unauthorized or

- 3 -

unintended access. As Asynchronous Transfer Mode (ATM) terminals become more common place this problem will become more critical.

We saw the need for a unique device that can be used to interconnect SONET network segments directly at the SONET signal level while selectively isolating and controlling the transport overhead data passing between the segments. Our invention, which we refer to as an Optical Service Unit (OSU), directly addresses this need by combining hardware technology from the SONET multiplexer industry with an embedded software package designed to control and monitor the SONET transport overhead.

There is very little prior art that relates to this application. Beyond the fact that SONET systems are relatively new, we believe the lack of prior art to also be related to the novel and unobvious nature of this device which runs counter to the open systems interconnection objectives of the SONET standards. The function represented by the Optical Service Unit is not defined in the SONET standards.

Background of the Invention

A search of the related classes and subclasses at the Patent and Trademark Office in Crystal City, Virginia revealed only a few patents the described optical interfaces similar to or supporting features of the Optical Service Unit. Most notable is U.S. Patent #5150243 issued to Suzuki, et al., of the Fujitsu Corporation that describes a device for remotely monitoring fiber optic network interfaces. A second related U.S. Patent was #445924, issued to Waschka, et al., of the Harris Corporation for a fiber optic local orderwire device.

These devices differ from the Optical Service Unit because they both terminate proprietary networks. The Optical Service Unit however acts as an mid-span intelligent interface between two standardized networks; the Optical Service Unit passes only the payload plus selected overhead data as programmed by the user.

- 4 -

The Optical Service Unit includes an orderwire function similar to that described by Waschka, but the implementation is based upon the embedded orderwire channels in the SONET transport overhead; Waschka use a wavelength multiplexing technique on a proprietary signal format.

If the search were to be extended to include electrical network interfaces, similarities could be found with a common device referred to as a Channel Service Unit, from which the Optical Service Unit derived its name. The Channel Service Unit terminates and isolates a digital trunk interface in order to protect the public network from harm due to improper voltage levels or signaling formats that may be introduced by the customer premise equipment. Channel Service Units can also be configured to monitor network performance and support basic network testing operations.

The electrical network however was never intended to be as fully open and interoperable as is the SONET network. Channel Service Units perform the very clear and well defined function of isolating the electrical network at its demarcation points. The Optical Service Unit will perform a similar function for the optical network however the task is far more complicated.

Unlike a Channel Service Unit, the Optical Service Unit can not totally isolate the SONET network. If it did, the benefits of having an extended network management system via the transport overhead would be lost. The Optical Service Unit must intelligently pass the transport overhead; allowing some but not all of the overhead data to pass.

The filtering function of the Optical Service Unit is not unlike that found in Local Area Network Routers. Routers examine the data traffic on the Local Area Network and pass only that data which meets a user defined set of criteria. Routers are commonly used to segment Local Area Networks for maintenance, performance, and security reasons.

In this application the functions of the Local Area Network Router are merged with the functions of a channel service unit; the product is then embedded in the hardware

technology of a SONET Multiplexer front-end to create an Optical Service Unit. This novel combination of features has been overlooked by industry and no similar device is known to exist or have been proposed to date.

The Summary Of The Invention

The Optical Service Unit provides a compact and cost effective means of interconnecting synchronous optical network segments while maintaining control over the network management information that passes through the interface.

Objects and Advantages

The objects and advantages of the present invention are:

- (a) To provide an intelligent and secure demarcation point between segments of a SONET fiber optic network;
- (b) To provide an intelligent and secure demarcation point between a network service provider and a customer premise;
- (c) To continuously monitor and record network performance monitoring data to assist network service providers in identifying network faults;
- (d) To provide automatic built-in-test functions and diagnostic loop-back capabilities to assist network service providers in isolating network faults;
- (e) To provide local and express orderwire functions to assist field service technicians coordinating network testing with other network sites;
- (f) To provide visual indications of the status of the SONET fiber optic interface;
- (g) To provide a modular fiber optic connection on the terminal side (customer premise) of the device to reduce faults caused by improper connection of customer premise equipment;
- (h) To eliminate the need for costly high-powered optical interfaces in customer premise equipment since the Optical Service Unit will drive the long range fiber.
- (i) To require less physical space than an equivalently configured set of back-to-back multiplexers;

- (j) It may be controlled and monitored by the network service provider via the SONET embedded network management data communication channels;

Disclosure of the Invention

- (k) It may be reprogrammed remotely by the network service provider via the SONET embedded network management data communication channels;
- (l) It may be controlled, monitored, and reprogrammed, locally via the craft interface serial computer interface port;
- (m) It may be programmed by the network service provider to restrict or eliminate access to the network management data communication channels;
- (n) It may be programmed to translate network management information where compatibility problems between vendor equipment may exist;
- (o) It may be interconnected with adjacent Optical Service Units to support centralized management of multiple units via one craft interface on one unit;
- (p) It may be interconnected with adjacent Optical Service Units to support Automatic Protection Switching;
- Further objects and advantages will become apparent from the ensuing description and drawings.

Brief Description of the Drawings

Figure 1 shows a block diagram of the Optical Service Unit.

Figure 2 shows an detailed block diagram of the main printed circuit board assembly within the Optical Service Unit.

Figure 3 shows the inter-relationships of the firmware tasks that execute the unit control functions.

Figure 4 shows the inter-relationships of the firmware tasks that execute the overhead processing functions.

Description of the Preferred Embodiment

An electrical diagram of the invention, hereinafter referred to as an Optical Service Unit, is illustrated in Figure 1. The optical service unit consists of a main

- 7 -

circuit board assembly 37, a display assembly 10, and a power supply assembly 21. In addition, various signal and control interfaces exist as described in the following text.

A craft interface 12 is provided for local maintenance access by field service personnel. This interface may be used to control, configure, test, and monitor the Optical Service Unit using a teletype, video terminal, or personal computer serial communications program.

To assist field service personnel with on-site testing the Optical Service Unit supports both local and express orderwire capabilities via an orderwire interface 18. The field service technician selects local or express orderwire operation using an orderwire switch 14. The relative amplitude of the orderwire audio is adjusted using an orderwire gain control 16. The orderwire may be selected to operate in bridged mode or terminal mode. The orderwire is activated and the mode is selected via the craft interface 12.

The Optical Service Unit may be powered from conventional 110/220 Volts Alternating Current line power via an AC power input 20. The unit may also be powered from 48 Volts Direct Current battery power using a DC power input 22.

A rear craft interface 24 is wired in parallel with the craft interface 12. The rear craft interface may be used for remote control of the unit via an external communications network or dial-up modem.

An alarm interface 26 provides form-C dry contact closures corresponding to minor, major, and catastrophic failures detected within the unit. Additional device control and status leads may be supported via this interface as required.

An OSU link interface 26 supports a high-speed digital communications interface that is used to interconnect adjacent Optical Service Units and related peripheral devices. This interface will be used to support automatic protection switching when implemented. It may also be used

to support a common management interface between multiple Optical Service Units.

A reference clock interface 30 provides a stable square-wave clock signal recovered from the facility side optical termination via a clock recovery module 38. A possible variation of this unit will allow the reference clock interface 30 to be used either as an output or as an input.

Synchronous optical communications signals on the terminal side of the Optical Service Unit are connected via a terminal optical interface 32 using a modular Fixed Shroud Duplex (FSD) connector with an integrated low power LED transmitter and receiver. Synchronous optical communications signals on the facility side of the Optical Service Unit are connected to a facility optical interface 33 via a facility fiber optic input 34 and a fiber optic output 36. The facility optical interface 33 uses conventional ST type connectors, however other standard fiber optic connector types may be directly substituted.

The display assembly 10 displays the status of several critical unit parameters that include: Power on/off (PWR), error detected (ERR), clock status (CLK), operations channel activity (EOC) and carrier alarms for both terminal and facility side optical interfaces. The carrier alarm indications include: Loss of signal (LOS), loss of frame (LOF), errored seconds (ERR), and alarm indication signal present (AIS).

The power supply assembly 21 consists of a switching power supply that can accept either AC or DC input voltages and a rectifier assembly that isolates the DC input connector 22 from the AC input connector 20, both on the rear of the unit.

An electrical block diagram of the main circuit board assembly 37 is illustrated in Figure 2.

The facility optical output 36 uses a solid state Intermediate Range LASER device with integral bias and modulation control circuitry. The facility optical input 34

uses a InGaAs PIN Photodiode with integral transimpedance amplifier and pseudo ECL data interface.

The received optical signal on the facility side of the unit is passed through a clock recovery module 38 prior to connection to a facility frame synchronizer 44. Framed data from the facility frame synchronizer 44 is then passed to a facility overhead terminator 48.

The synchronous optical communications signal contains an overhead component and a payload component. The overhead component carries framing information, performance monitoring data, network management data, user control data, and the local and express orderwire channels. The payload component carries the actual traffic bearing content of the signal.

The facility overhead terminator 48 extracts the overhead information from the received signal and places it in a memory mapped region of the facility overhead central processing unit 62 address space. The payload content of the received signal is passed directly by terminator 48 to a payload frame buffer 50. Frame buffer 50 is a First-In-First-Out (FIFO) buffer that compensates for variations in payload frame alignment between the facility and terminal sides of the device. The payload frame buffer 50 can be modified in future versions of the device to perform payload-only processing such as encryption.

The received facility payload is then passed from the payload frame buffer 50 to a terminal overhead terminator 46. Overhead data supplied by a terminal overhead central processing unit 60 is appended to the payload and then forwarded to a terminal frame synchronizer 42. Frame synchronizer 42 randomizes and frames the data prior to transmission to the terminal optical interface 32.

The terminal optical interface 32 is a receiver-transmitter assembly with an integral Fixed Shroud Duplex (FSD) fiber optic connector. The optical transmitter portion of the Modular Fiber Optic Interface is a low power edge-emitting ELED source suitable for short range fiber optic interfaces. The receiver portion is a MOVPE planar PIN

- 10 -

photodiode. The module includes integral data interfaces and modulator circuitry.

For optical signals received on the terminal side of the Optical Service Unit, the data path is the reverse of that described for optical signals received on the facility side of the device.

The terminal frame synchronizer 42, terminal overhead terminator 46, terminal overhead central processing unit 60, together with the various peripheral devices as illustrated in Figure 2 comprise a terminal processor 41. In similar fashion, the facility frame synchronizer 44, facility overhead terminator 48, facility overhead central processing unit 62, together with illustrated in Figure 2 comprise a terminal processor 41. In various peripheral devices as illustrated in Figure 2 comprise a facility processor 43.

The terminal processor 41 and the facility processor 43 communicate with each other and a unit controller 81 via inter processor data links. The inter processor data links are memory mapped within the address space of the terminal overhead central processor unit 60, the facility overhead central processor unit 62, and the unit controller central processing unit 82 via bus interface modules 68, 70, and 72 respectively.

The terminal overhead central processor unit 60 passes the orderwire data taken from the terminal overhead terminator 46 to a terminal orderwire channel interface 64. The facility overhead central processor unit 62 passes the orderwire data taken from the facility overhead terminator 48 to a facility orderwire channel interface 66. The two orderwire channel interfaces buffer and clock the encoded orderwire data to and from an audio bridge module 74 at 64 kbps.

The audio bridge module 74 contains two PCM codecs that perform the digital to analog conversion. The module also bridges the orderwire audio with the local orderwire interface 18 and provides a gain stage to deliver sufficient output to drive a standard lineman's handset. The gain of

- 11 -

the module is adjusted via the orderwire gain control 16 (Fig 1).

The audio bridge module 74 is controlled and monitored by the unit control central processor unit 82 via an audio bridge interface 84. Bridge interface 84 is a parallel interface that is memory mapped within the address space of the unit control central processor unit 82. The state of the orderwire select switch 14 (Fig 1) is also read by the unit control central processor unit 82 via the audio bridge interface 84.

The unit control central processing unit 82 is responsible for monitoring various component performance indicators within the Optical Service Unit. It does this via a sensor interface 76 connected to an analog sensor module 40. The analog sensor module 40 is an assembly of analog to digital converters calibrated to measure the optical receive power, LASER bias current, and case temperature of the facility and terminal side optical interface components. The sensor interface 76 is a parallel interface that is memory mapped within the address space of the unit control central processor unit 82.

The unit control central processor unit 82 also interfaces with a system clock 78, a unit serial interface 86, and a unit parallel interface 88. The system clock 79 is a battery backed date and time device that returns the current calendar date and time of day.

The unit serial interface 86 is a dual port universal synchronous asynchronous receiver transmitter (USART) device that supports most common serial interface protocols. One port of unit serial interface 86 is used for the craft interface 12 and rear craft interface 24, which are wired together in parallel. The second port of unit serial interface 66 is used by the OSU link interface 29.

The unit parallel interface 88 drives form-C contact closure relays for the alarm interface 26 and lamp drivers for the display assembly 10. Control lines (not shown in Fig. 2) from the interface are also used to reset the

- 12 -

terminal overhead central processor unit 60 and facility overhead central processor unit 62.

A watchdog timer assembly 134 protects the unit control central processor unit 82 from becoming locked-up or halted in an illegal state. Timer 134 must be periodically set by the CPU 82 or it will force a hardware reset of the unit upon expiration. Timer 134 also controls power-up sequencing and issues a hardware reset to the CPU 82 after power supply voltages have stabilized and the unit is ready to boot.

The terminal overhead central processor unit 60, the facility overhead central processor unit 62, and the unit control central processor unit 82, each have an independent memory area consisting of both Random Access Memory (RAM) and Electronically Erasable Programmable Read Only Memory (EEPROM). These are represented by the terminal memory 56, facility memory 58, and unit memory 80 modules respectively. EEPROM is used to store the executable program firmware, to maintain the most recent performance monitoring data, and to maintain the most recent unit configuration. RAM is used for real-time manipulation of data and storage of variable and temporary data. The executable firmware is copied from the EEPROM to RAM to improve program performance.

The Optical Service Unit firmware which largely determines the operational characteristics of the unit is divided into two major programs; a unit control program 90 (Fig 3) and an overhead processor program 92 (Fig 4).

The unit control program 90 (Fig 3) is built upon a real-time multi-tasking embedded operating system. A unit control main task 96 is the primary executable task that boot-straps the firmware, initializes the operating system, and spawns an orderwire task 98, sensor interface task 100, display and alarm task 102, TTY interface task 104, PM and BIT task 106, unit configuration control task 108, OSU link interface task 110, and unit inter processor communications task 112. The unit control program 90 is stored in unit memory 80 and executes on the unit controller central processor unit 82.

- 13 -

The overhead processor program 92 (Fig 4) is built upon the same real-time multi-tasking embedded operating system used in the unit control program 90. An overhead processor main task 118 is the primary executable task that boot-straps the firmware, initializes the operating system, and spawns an overhead inter processor communications task 120, PM and BIT task 122, payload processing task 124, overhead data task 126, DDC interface task 129, message processing task 130, and overhead orderwire task 132. The overhead processor program 92 is stored in two locations; One copy is stored in terminal memory module 56 and executes on the terminal overhead central processor unit 60. The second copy is stored in the facility memory module 58 and executes on the facility overhead central processing unit 62.

The unit control program 90 and the overhead processor program 92 are built upon object oriented software design techniques. Each task within a program performs a specific function and communicates with other tasks via standardized message queues supported by the embedded operating system. The same standardized message format is extended to inter-processor communications between the unit controller 81, the facility processor 43, and the terminal processor 41.

The unit commences operation upon application of primary power to the main circuit board assembly 37. The watchdog timer 134 issues a reset command to the unit control central processor unit 82 forcing a boot-strap operation to begin. The Unit Control Program 90 (Fig. 3) is loaded and the unit control main task 96 begins execution.

The unit control main task 96 loads and activates the remaining tasks in the unit control program 90 then performs a built-in-self- test to validate the processor's operational integrity. The unit controller 81 then resets the facility overhead central processor unit 62 and the terminal overhead central processor unit 60 to force a boot-strap load of their respective copies of the overhead processing program 92 (Fig 4).

- 14 -

The overhead processor main task 118 begins execution in each of the overhead processors and loads the remaining tasks in the overhead processing program 92. A built-in-self-test is performed to validate the operational integrity of the processor and a successful start-up message is sent from the each overhead processor to the unit controller 81. If unit controller 81 does not receive a valid start-up messages from the facility processor 43 and the terminal processor 41 within a predetermined amount of time an error condition is declared and the Optical Service Unit will shut down.

If the overhead processors load successfully they immediately begin processing the synchronous optical communications signal overhead information. The DDC interface task 128 begins receiving the network operations message traffic contained in the DDC channels located within the overhead and forwards all received messages to the message processing task 130.

The message processing task 130 examines the received messages to determine the proper handling required. Based upon user definable criteria the message may be forwarded via the overhead inter processor communications task 120 to the opposing overhead processor, or it may be terminated locally, or it may be returned to sender, or it may be modified and forwarded. If the message is a control message directed to the Optical Service Unit itself, the message is forwarded to the unit controller 81.

The facility and terminal versions of the overhead processor program 92 need not have identical message handling criteria. For example, the message processing task 92 on the terminal processor 41 may be programmed to terminate any control messages received and forward an alarm indication. Control messages however that are received on the facility processor 43 would be accepted and forwarded to the unit controller 81.

The overhead PM and BIT task 122 in the overhead processor program 92 accumulates performance monitoring data contained within the synchronous optical communications

- 15 -

signal overhead. Statistics are periodically sent to the unit controller 81 where they are maintained in unit memory 80 for later retrieval. The overhead PM and BIT task 122 also controls the diagnostic loopback capabilities of the frame synchronizers (42 & 44).

The payload processing task 124 manages the serial payload interface between the payload frame buffer 50 and the respective processor's overhead terminator (46 & 48).

The overhead data task 126 manages the non-message based overhead data bytes. Where appropriate, the non-messaged based overhead data is forwarded to the opposing overhead processor via the overhead inter processor communications task 120.

The overhead orderwire task 132 manages the serial interface between the orderwire channels in the optical signal overhead and the orderwire channel interfaces (66 & 68). Command messages received from the unit controller 81 via the inter processor communications task 120 determine whether the orderwire is operating in local or express mode.

The unit control program 90 (Figure 3) monitors and controls the overall activity of the Optical Service Unit. Upon successful loading and activation of the terminal and facility processors, 41 and 43 respectively, the unit control main task 96 enters an idle do-forever state waiting for command, status, or error messages to arrive.

Command and control messages may be received locally via the TTY Interface task 104 or via the unit inter processor communications task 112 having been received by either the terminal processor 41 or the facility processor 43. Status messages are generated periodically by the overhead processors to report performance monitoring conditions to the unit PM and BIT task 106. Error messages may be generated autonomously by any task detecting an error condition.

The TTY interface task 104 provides a command line interpreter and display interface designed for operation with teletypes, video terminals, or personal computer terminal emulator programs. A menu mode is supported with an on-line

- 16 -

help facility to assist field service personnel with operation of the unit. The TTY Interface task 104 is password protected and reports all local access to the unit via the facility DDC interface.

The unit configuration control task 108 maintains the current hardware and software configuration of the unit, including all message processing algorithms and rules. It is possible to reprogram parts or all of the Optical Service Unit via download commands. Task 108 supervises the software load, programs the EEPROM contained with the unit memory 80 and validates the integrity of the data. Using the unit inter processor communications task 112 the terminal and facility memories, 56 and 58, may be reprogrammed as well.

The OSU link interface task 110 supports a high-speed digital interface for use in communicating between multiple Optical Service Units. Task 110 will also support a protection switching peripheral when implemented.

The unit orderwire task 98 manages the orderwire interface 18. It is responsible for tracking the state of orderwire select switch 14 and for controlling the operation of audio bridge module 74 (Fig 2) and for controlling the operation of the overhead orderwire task 132 (Fig 4) operating in both the terminal and facility processors 41 and 43 respectively. The orderwire may operate in either an additive party-line mode or in terminating drop-line mode.

The PM and BIT task 106 accumulates performance monitoring statistics from the facility and terminal Processors, 41 and 43, and generates reports upon request. Reports may be requested from the local craft interface or remotely via the DCC channels contained within the synchronous optical communications signal overhead. All status and error messages are date and time stamped based upon the battery backed-up clock 78.

The sensor interface task 100 monitors the analog sensors 40 which measure the received power and LASER bias currents of the terminal and facility optical interfaces, 32

- 17 -

and 33 respectively. If user programmed thresholds are violated, then the task broadcasts an alarm message.

During normal operation, the Optical Service Unit requires no local support and minimal remote support; it may be managed entirely via the facility optical signal overhead. Typically, the unit is programmed to pass only a certain class of messages and terminate all others; the unit automatically begins message processing whenever power is applied.

Any detected error conditions are reported via the facility optical interface and local alarm contact closures. If a local terminal is connected to the craft interface an alarm message will be displayed. An external modem connection may be used by the service provider as an additional redundant means to access the unit in the event of a fiber failure.

During maintenance operations, the Optical Service Unit may be controlled both locally via the craft interface or remotely via the facility optical signal overhead. Performance monitoring information may be retrieved for each 15 minute interval of the prior 24 hours with daily summaries maintained for seven days. Various test and diagnostic functions may also be implemented to support field test operations.

Service providers may use the Optical Service Unit to determine if the optical span is functioning properly up to the demarcation point. A principal feature of the unit is the modular fiber optic connector used on the terminal optical interface that allows a field service technician to rapidly disconnect the customer premise equipment and install a test terminal to validate the proper operation of the line. The customer premise equipment may then be easily reconnected at the end of the test.

Custom overhead and message processing programs can be installed by the service provider to solve translation problems between incompatible network elements. Using the Optical Service Unit, a service provider can operate the

network with a common Network Management System while accommodating the subtle dissimilarities likely to be found between vendor's equipment.

The Optical Service Unit provides the service provider with a standardized intelligent modular demarcation point. A typical embodiment of the device will be suitable for rack mounting in an EIA standard equipment rack occupying only 1.75 inches of vertical rack space. Other variations of the unit include but are not limited to: shelf mount configurations, wall mount configurations, and sealed enclosures for outdoor or industrial use.

Accordingly, the reader will see that the Optical Service Unit improves upon any method or device currently in use today for joining independent SONET network segments together or for extending a SONET network to a customer premise. The Optical Service Unit permits service providers to:

- ° Extend network services at SONET optical rates without jeopardizing network management security;
- ° Manage customer premise demarcation points effectively with automatic performance monitoring and diagnostic capabilities;
- ° Solve interface compatibility problems via the overhead translation features of the unit;
- ° Provide a standardized network interface to the customer premise using modular fiber optic connectors thus reducing problems associated with incorrect connection and simplifying testing by field service technicians.

Although the description above contains many specificities, these should not be construed as limiting the scope of the invention but as merely providing illustrations of some of the preferred embodiments of the invention. For example, the Optical Service Unit can be repackaged for operation in a multiunit shelf mount configuration or an outdoor environmentally rigidized configuration; the optical interfaces on either terminal or facility sides of the device may be replaced with optical interfaces varying in power,

wavelength, or physical termination, etc.; the SONET OC-3 rate of the optical signal may be varied to any standard SONET OC-N rate, where N is an integer from 1 to 96; the overhead processors may be programmed to perform payload processing or path overhead processing; a payload encryption capability can be added at the central stage of the device.

Thus the scope of the invention should be determined by the appended claims and their legal equivalents, rather than by the examples given.

Claims

We claim:

1. An optical communications network interface device comprising:

(a) a terminal optical interface for transmitting and receiving a terminal synchronous optical network communications signal,

(b) a facility optical interface for transmitting and receiving a facility synchronous optical network communications signal,

(c) a terminal processor operatively connected to said terminal optical interface comprising;

(d) a terminal frame synchronizer,

(e) a terminal overhead terminator operatively connected to the terminal frame synchronizer,

(f) a terminal overhead central processing unit operatively connected to the terminal overhead terminator,

(g) means within the terminal overhead terminator for demultiplexing said terminal synchronous optical network communications signal into a received terminal payload component and a received terminal overhead component,

(h) means within the terminal central processing unit for monitoring and manipulating said received terminal overhead component whereby the content of the overhead component may be restricted to a user defined subset of allowable values,

(i) means within the terminal overhead terminator for multiplexing a transmitted terminal payload component and a transmitted terminal overhead component into said terminal synchronous optical network communications signal,

(j) a facility processor, operatively connected to said facility optical interface comprising;

(k) a facility frame synchronizer,

- 21 -

- (l) a facility overhead terminator operatively connected to the facility frame synchronizer,
- (m) a facility overhead central processing unit operatively connected to the facility overhead terminator,
- (n) means within the facility overhead terminator for demultiplexing said facility synchronous optical network communications signal into a received facility payload component and a received facility overhead component,
- (o) means within the facility central processing unit for monitoring and manipulating said received facility overhead component whereby the content of the overhead component may be restricted to a user defined subset of allowable values,
- (p) means within the facility overhead terminator for multiplexing a transmitted facility payload component and a transmitted facility overhead component into said facility synchronous optical network communications signal,
- (q) a process and interconnection means between said facility processor and said terminal processor for;
- (r) changing said received terminal overhead component to said transmitted facility overhead component,
- (s) changing said received terminal payload component to said transmitted facility payload component,
- (t) changing said received facility overhead component to said transmitted terminal overhead component, and
- (u) changing said received facility payload component to said transmitted terminal payload component,
- (v) a unit controller operatively connected to the terminal processor and the facility processor comprising;

- 22 -

(w) a unit control central processing unit,
(x) a means, operatively connected to the unit control central processing unit, for providing local command and control access, status displays, alarm indication, and configuration control,
(y) a means, operatively connected to the unit control central processing unit, for providing remote command and control access, status reports, alarm indication, and configuration control,
(z) A means, operatively connected to the unit control central processing unit, for monitoring the internal functionality of said optical communications interface device and reporting any malfunction.

2. An optical communications network interface device as set forth in claim 1, wherein said terminal processor and said facility processor contain a means for controlling and monitoring overhead information within said terminal synchronous optical network communication signal and said facility synchronous optical network communications signal in accordance with predetermined user specifications.

3. An optical communications network interface device as set forth in claim 1, wherein said unit controller contains a data interface and means for connecting and operating a plurality of said unit controllers from a single location.

4. An optical communications network interface device as set forth in claim 1, wherein said process and interconnection means between said facility processor and said terminal processor includes an apparatus and means for encrypting the payload components.

5. An optical communications network interface device as set forth in claim 1, comprising an orderwire interface and means for controlling said orderwire interface.

6. An optical communications network interface device as set forth in claim 1, wherein said terminal optical interface includes a modular fiber optical connector,

allowing standardized terminal cable assemblies to be rapidly and reliably installed or removed as required.

7. A method for demarcating a synchronous optical network communications signal interconnected between a facility and a terminal comprising the steps of:

- (a) defining the overhead information contained within said synchronous optical network communications signal to be restricted,
- (b) defining the overhead information contained within said synchronous optical network communications signal to be passed through said device without manipulation,
- (c) defining the overhead information contained within said synchronous optical network communications signal to be translated,
- (d) installing an optical communications network interface device at the desired demarcation point of said synchronous optical network communication signal comprising;
 - (e) a standardized modular fiber optic connector for a terminal interface,
 - (f) a standardized modular fiber optic connector for a facility interface,
 - (g) a means interposed between the terminal interface and the facility interface for manipulating the overhead information contained with said synchronous optical network communication signal,
- (h) programming said optical communications network interface device to implement said restrictions and said translations, and to pass the restricted, translated and unmanipulated overhead information from the facility to the terminal or from the terminal to the facility via the facility and terminal interfaces
- (i) activating said optical communications network interface.

8. An optical communications network interface device as set forth in claim 1, wherein said process and

interconnection means between said facility processor and said terminal processor includes a means for translating dissimilar overhead components.

9. An optical communications network device, comprising:

a first optical interface for receiving an optical signal;

a processor including,

means for splitting the optical signal into a payload component and an overhead component,

means for monitoring the overhead component to determine if it contains prohibited information,

means for restricting the overhead component to exclude any prohibited information, and

means for combining the payload component and the restricted overhead component into a restricted optical signal; and

a second optical interface for transmitting the restricted optical signal.

10. An optical communications network device as set forth in claim 9, having at least two processors, wherein the first processor receives a first optical signal from the first optical interface and provides a first restricted optical signal to the second optical interface, and the second processor receives a second optical signal from the second optical interface and provides a second restricted optical signal to the first optical interface.

11. An optical communications network device as set forth in claim 9, wherein the processor further includes a means for encrypting and decrypting the payload components.

12. An optical communications network device as set forth in claim 9, wherein the second optical interface can both receive the optical signal and transmit the restricted optical signal, and the first optical interface can both receive the optical signal and transmit the restricted optical signal.

13. An optical communications network device as set forth in claim 9, further comprising:

an orderwire interface; and

means for controlling the orderwire interface.

14. An optical communications network device as set forth in claim 9, wherein the processor includes a means for translating dissimilar overhead components.

15. An optical communications network device as set forth in claim 9, further comprising:

a controller for controlling the operation of the optical communications network device.

16. An optical communications network device as set forth in claim 15, wherein the controller further comprises a data interface allowing the controller to be connected to one or more optical communication network devices, and to control the operation of the one or more optical communication network devices.

17. An optical communications network device, comprising:

means for receiving an optical signal;

means for separating the optical signal into a payload component and an overhead component;

means for monitoring the overhead component to determine if the overhead component contains prohibited information;

means for restricting the overhead component to exclude any prohibited information determined by the monitoring means; and

means for transmitting a restricted optical signal comprising the payload component and the restricted overhead component.

18. A method for demarcating a synchronous optical network communications signal interconnected between a facility and a terminal comprising the steps of:

receiving the synchronous optical network communications signal from either the facility or the terminal;

determining the overhead information contained within said synchronous optical network communications signal that must be restricted;

restricting the synchronous optical network communications signal to exclude the restricted overhead information; and

passing the restricted synchronous optical network communications signal to the other of either the facility or the terminal.

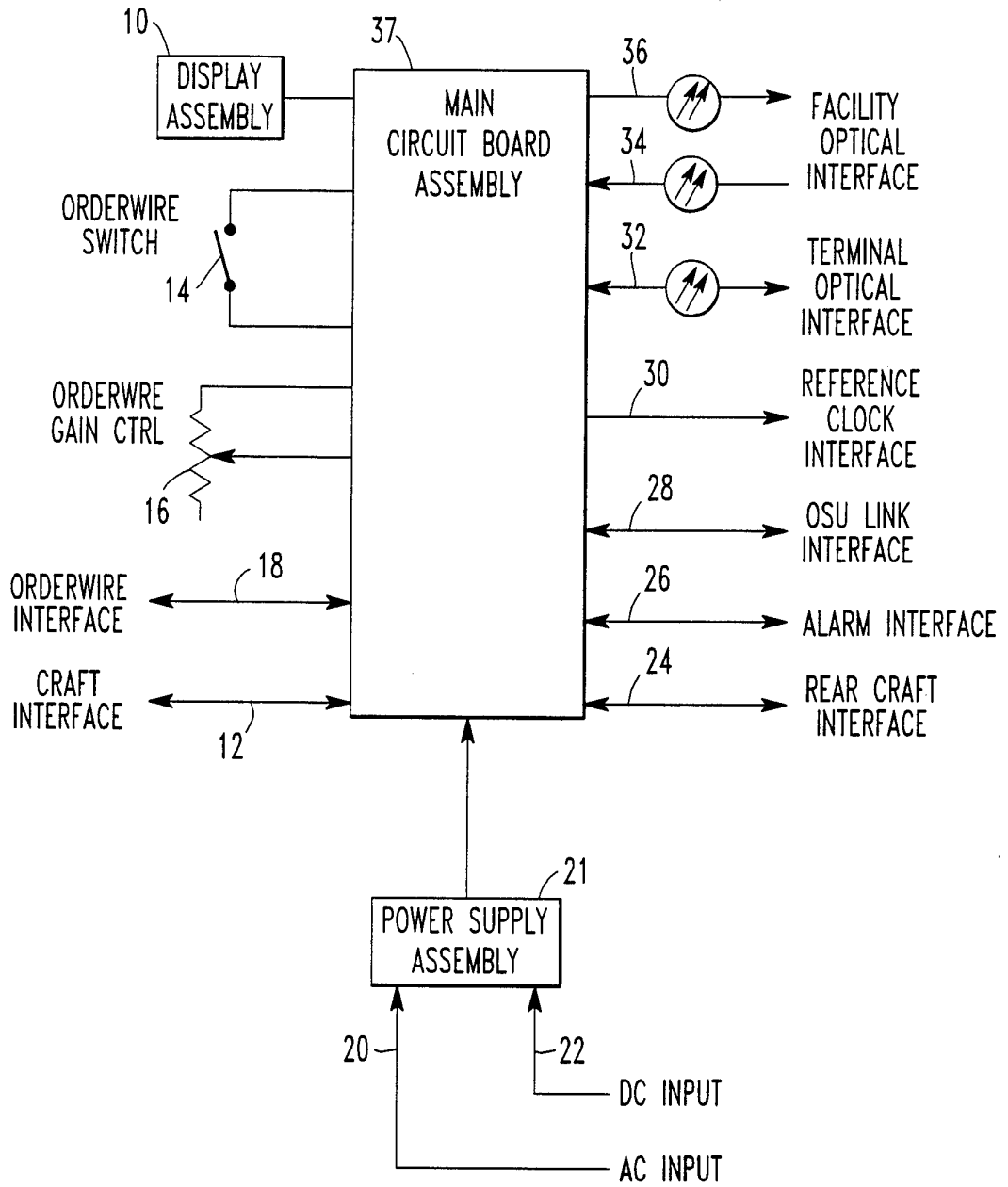

FIG. 1

FIG. 2

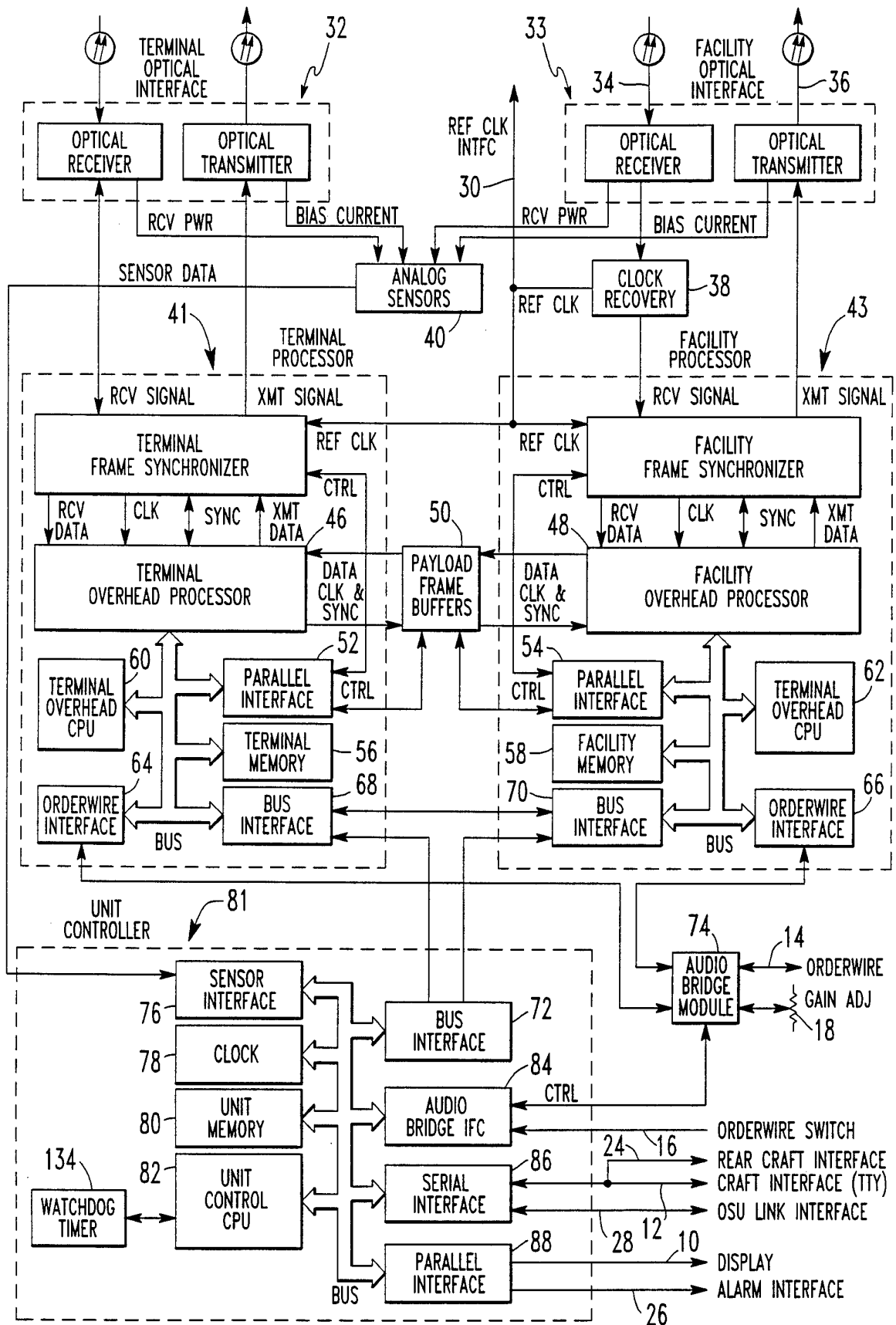

FIG. 3

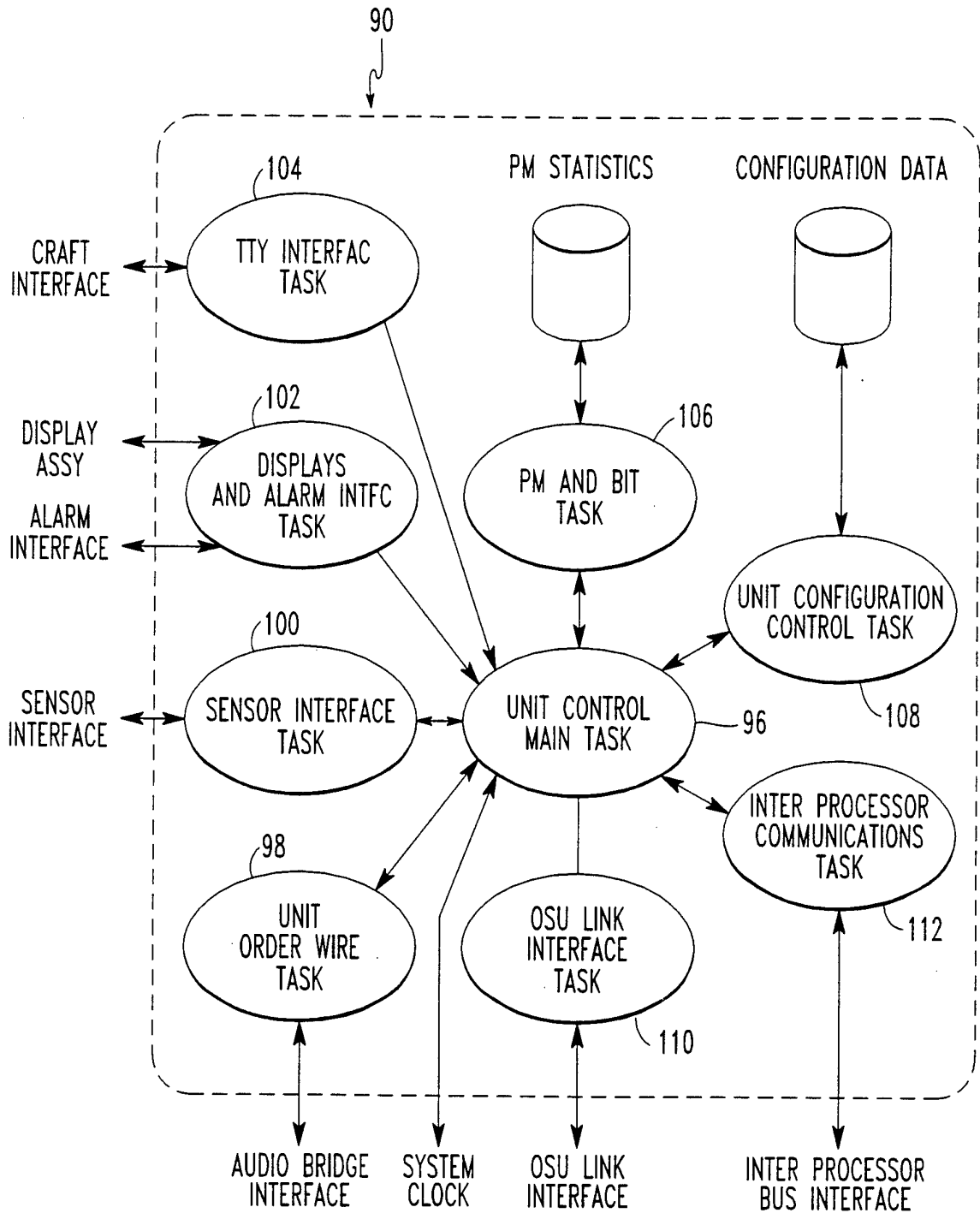
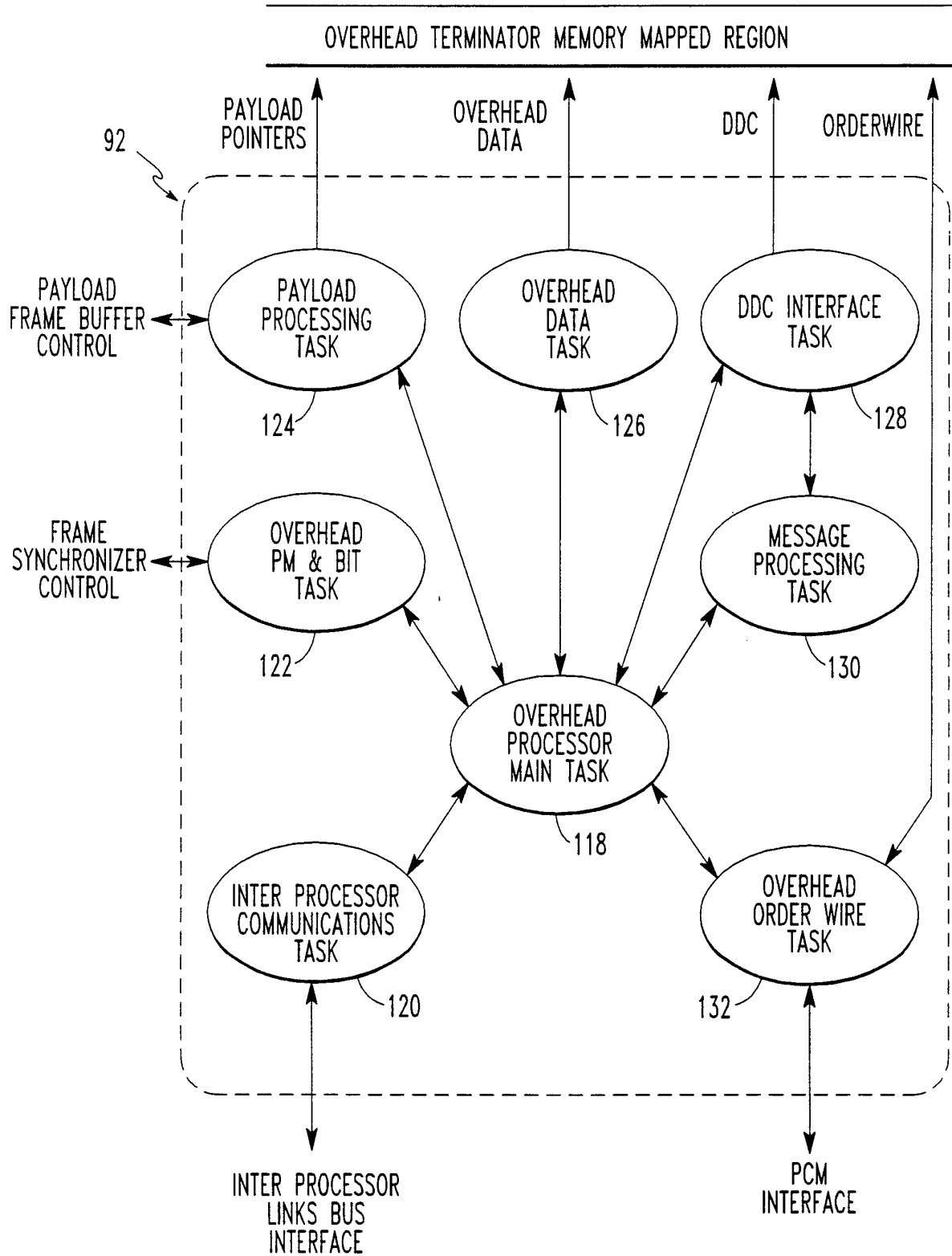

FIG. 4



INTERNATIONAL SEARCH REPORT

International Application No

PCT/US 94/06632

A. CLASSIFICATION OF SUBJECT MATTER
 IPC 6 H04J3/16 H04J3/12 H04J3/14

According to International Patent Classification (IPC) or to both national classification and IPC

B. FIELDS SEARCHED

Minimum documentation searched (classification system followed by classification symbols)
 IPC 6 H04J

Documentation searched other than minimum documentation to the extent that such documents are included in the fields searched

Electronic data base consulted during the international search (name of data base and, where practical, search terms used)

C. DOCUMENTS CONSIDERED TO BE RELEVANT

Category *	Citation of document, with indication, where appropriate, of the relevant passages	Relevant to claim No.
A	<p>ELECTRICAL COMMUNICATION, vol.64, no.2/3, June 1990, ROMFORD, GB pages 194 - 204, XP237654 H. AHMED ET AL. 'Synchronous Transmission Systems and Cross Connects for Broadband Networks' see page 197, left column, paragraph 2 see page 198, right column, paragraph 4 - page 199, left column, paragraph 1 see page 199, left column, paragraph 6 see page 201, left column, paragraph 2 see page 201, left column, paragraph 5; figures 2,4</p> <p align="center">--- -/--</p>	<p>1,3, 5-10, 12-18</p>

Further documents are listed in the continuation of box C.

Patent family members are listed in annex.

* Special categories of cited documents :

- "A" document defining the general state of the art which is not considered to be of particular relevance
- "E" earlier document but published on or after the international filing date
- "L" document which may throw doubts on priority claim(s) or which is cited to establish the publication date of another citation or other special reason (as specified)
- "O" document referring to an oral disclosure, use, exhibition or other means
- "P" document published prior to the international filing date but later than the priority date claimed

- "T" later document published after the international filing date or priority date and not in conflict with the application but cited to understand the principle or theory underlying the invention
- "X" document of particular relevance; the claimed invention cannot be considered novel or cannot be considered to involve an inventive step when the document is taken alone
- "Y" document of particular relevance; the claimed invention cannot be considered to involve an inventive step when the document is combined with one or more other such documents, such combination being obvious to a person skilled in the art.
- "&" document member of the same patent family

Date of the actual completion of the international search 17 October 1994	Date of mailing of the international search report 21.10.94
Name and mailing address of the ISA European Patent Office, P.B. 5818 Patentlaan 2 NL - 2280 HV Rijswijk Tel. (+ 31-70) 340-2040, Tx. 31 651 epo nl, Fax: (+ 31-70) 340-3016	Authorized officer Pieper, T

INTERNATIONAL SEARCH REPORT

International Application No
PCT/US 94/06632

C.(Continuation) DOCUMENTS CONSIDERED TO BE RELEVANT		
Category	Citation of document, with indication, where appropriate, of the relevant passages	Relevant to claim No.
A	<p>FUNKSCHAU, vol.63, no.14, 28 June 1991, MUNCHEN DE pages 56 - 62, XP237686 R. WIECHERS 'Ein neuer Standard verändert die Welt' see page 62, left column, paragraph 4 - right column, paragraph 3; figure 4 -----</p>	<p>1,7,9, 17,18</p>
A	<p>US,A,4 924 460 (LUBARSKY ET AL.) 8 May 1990 see column 4, line 51 - line 61 see column 6, line 17 - line 25 see column 7, line 26 - column 8, line 11 see column 14, line 16 - line 57 see column 17, line 8 - column 18, line 15; figures 2-4 -----</p>	<p>1-4,7, 9-12, 15-18</p>

INTERNATIONAL SEARCH REPORT

Information on patent family members

International Application No

PCT/US 94/06632

Patent document cited in search report	Publication date	Patent family member(s)	Publication date
US-A-4924460	08-05-90	NONE	