



INTERNATIONAL APPLICATION PUBLISHED UNDER THE PATENT COOPERATION TREATY (PCT)

<p>(51) International Patent Classification ⁶ : H04N 7/10, 7/173, G09B 5/14</p>	<p>A1</p>	<p>(11) International Publication Number: WO 95/24796 (43) International Publication Date: 14 September 1995 (14.09.95)</p>
--	-----------	---

(21) International Application Number: PCT/US95/02017
 (22) International Filing Date: 15 February 1995 (15.02.95)
 (30) Priority Data:
 08/207,779 8 March 1994 (08.03.94) US
 (71) Applicant: APPLE COMPUTER, INC. [US/US]; 20525 Mariani Avenue, Cupertino, CA 95014 (US).
 (72) Inventors: BUTAH, Jon, D.; 385 Calabazas Road, Watsonville, CA 95076 (US). DOYLE, Mark, T.; 431 Ewell Drive, Aptos, CA 95003 (US). GLASS, Steven, E.; 1229 Rousseau Drive, Sunnyvale, CA 94087 (US).
 (74) Agents: SCHELLER, James, C. et al.; Blakely, Sokoloff, Taylor & Zafman, 7th floor, 12400 Wilshire Boulevard, Los Angeles, CA 90025 (US).

(81) Designated States: AM, AT, AU, BB, BG, BR, BY, CA, CH, CN, CZ, DE, DK, EE, ES, FI, GB, GE, HU, JP, KE, KG, KP, KR, KZ, LK, LR, LT, LU, LV, MD, MG, MN, MW, MX, NL, NO, NZ, PL, PT, RO, RU, SD, SE, SI, SK, TJ, TT, UA, UZ, VN, European patent (AT, BE, CH, DE, DK, ES, FR, GB, GR, IE, IT, LU, MC, NL, PT, SE), OAPI patent (BF, BJ, CF, CG, CI, CM, GA, GN, ML, MR, NE, SN, TD, TG), ARIPO patent (KE, MW, SD, SZ, UG).

Published
 With international search report.

(54) Title: SLECTABLE AUDIO/VIDEO (A/V) DISTRIBUTION USING MULTI-MEDIA WORKSTATIONS, MULTI-CHANNEL A/V NETWORK, AND DIGITAL DATA NETWORK

(57) Abstract
 A number of multi-media workstations having network and audio/visual (A/V) software are provided to a master control and a number of user stations, and these multi-media workstations are coupled to a number of A/V sources and each other via a multi-channel A/V network and digital data network. Each of the multi-media workstations is equipped with a multi-channel analog A/V signal receiver, a digital data network interface, a high performance processor, A/V digitization and rendering circuitry, a high pixel density display, and speakers. The multi-media workstations are further equipped with an operating system having integrated network and A/V services, an A/V command handler module, an audio distribution module, an A/V command control module, and a number of A/V applications. The multi-media workstation provided to the master control station is further equipped with a master A/V control module. Together, these elements cooperate to allow A/V materials to be selectably distributed to the multi-media workstations.

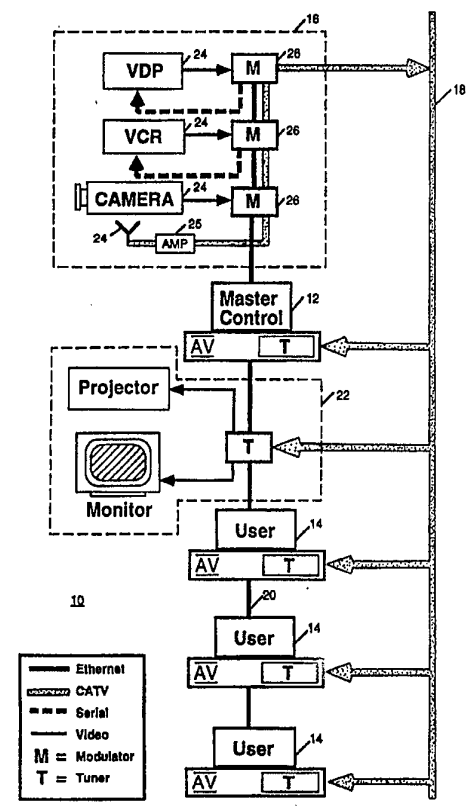

FOR THE PURPOSES OF INFORMATION ONLY

Codes used to identify States party to the PCT on the front pages of pamphlets publishing international applications under the PCT.

AT	Austria	GB	United Kingdom	MR	Mauritania
AU	Australia	GE	Georgia	MW	Malawi
BB	Barbados	GN	Guinea	NE	Niger
BE	Belgium	GR	Greece	NL	Netherlands
BF	Burkina Faso	HU	Hungary	NO	Norway
BG	Bulgaria	IE	Ireland	NZ	New Zealand
BJ	Benin	IT	Italy	PL	Poland
BR	Brazil	JP	Japan	PT	Portugal
BY	Belarus	KE	Kenya	RO	Romania
CA	Canada	KG	Kyrgystan	RU	Russian Federation
CF	Central African Republic	KP	Democratic People's Republic of Korea	SD	Sudan
CG	Congo	KR	Republic of Korea	SE	Sweden
CH	Switzerland	KZ	Kazakhstan	SI	Slovenia
CI	Côte d'Ivoire	LI	Liechtenstein	SK	Slovakia
CM	Cameroon	LK	Sri Lanka	SN	Senegal
CN	China	LU	Luxembourg	TD	Chad
CS	Czechoslovakia	LV	Latvia	TG	Togo
CZ	Czech Republic	MC	Monaco	TJ	Tajikistan
DE	Germany	MD	Republic of Moldova	TT	Trinidad and Tobago
DK	Denmark	MG	Madagascar	UA	Ukraine
ES	Spain	ML	Mali	US	United States of America
FI	Finland	MN	Mongolia	UZ	Uzbekistan
FR	France			VN	Viet Nam
GA	Gabon				

**SELECTABLE AUDIO/VIDEO (A/V) DISTRIBUTION USING
MULTI-MEDIA WORKSTATIONS, MULTI-CHANNEL A/V
NETWORK, AND DIGITAL DATA NETWORK**

BACKGROUND OF THE INVENTION

1. Field of the Invention:

The present invention relates to the fields of computer systems, audio/video (A/V) devices, and networking. More specifically, the present invention relates to selectable A/V distribution to a number of local and/or remote stations.

2. Glossary of Terms:

For the purpose of this disclosure, the intended meanings of certain key terms are as follows:

a) a personal computer is intended to mean a microprocessor based computer equipped to handle traditional text and graphics data;

b) a multi-media computer is intended to mean an enhanced personal computer equipped to handle digitized video and sound data as well as traditional text and graphics data, the digitized video and sound data being received from a digital A/V player, such as a CD-ROM, playing an A/V title stored on a digital media, such as a CD, in digitized form;

c) a multi-media workstation is intended to mean an enhanced multi-media computer equipped to digitize analog A/V signals into digital video and sound data, as well as being able to handle them.

3. **Background:**

Today, many business or education applications desire selectable A/V distribution to local and/or remote stations in a cost effective manner. Since very often these local or remote stations also desire computing capability, it is more cost effective to have both desires satisfied with common equipment.

In one educational system adapted for classroom usage known in the art, A/V materials are selectably distributed from one of a number of A/V sources to a number of teacher and student personal computers in a classroom under the control of the teacher's personal computer. The selectable A/V distribution is accomplished using three independent networks, a "peer to peer" digital data communication network, a star type analog video distribution network, and a star type analog audio and keystroke distribution network. In addition to standard personal computer equipment such as color graphics monitor, each personal computer is equipped with a "peer to peer" digital data communication network interface and a custom analog video input/output (I/O) interface. Additionally, each student personal computer is provided with a custom complementary analog audio and keystroke I/O unit.

Furthermore, the system is provided with a custom analog video distribution unit, and a customer analog audio and keystroke distribution unit.

Beside the disadvantages that the system requires three independent networks and costly custom equipment to accomplish the desired selectable distribution, the system also has the following disadvantages:

- a) the students cannot control the A/V sources;
- b) without adding expensive redundant circuitry in the analog A/V distribution unit, the prior art system cannot concurrently distribute multiple A/V materials to different combinations of student personal computers;
- c) the student personal computers are turned into passive "TV monitors" when A/V materials are distributed to them, making the student personal computers unavailable for other concurrent usages;
- d) the A/V materials are not capturable on the student personal computers as video and sound data inputs to other processing for learning purpose.

The last disadvantage is particularly undesirable in view of the fact that the desired computer aided educational systems of the future are those that allow students to learn through active participation. Education experts have come to recognize that students learn best when

they can construct their own knowledge to represent their understanding of a subject matter, using video, sound, as well as text.

In U.S. Patent 4,920,432, a business system adapted for hotel and hospital usage is disclosed. A/V materials are selectably distributed from a number of A/V players/sources in an A/V library to a number of remote user terminals under the control of a system supervisor computer and the supervision of a master user terminal. The selectable A/V distribution is accomplished using two independent networks, a digital data communication network, and a multi-frequency analog A/V distribution network. In addition to standard personal computer equipment such as color graphics monitor, a typical user terminal is further equipped with a digital data communication network interface and a tuner. The master user terminal and the system supervisor computer are similarly constituted as the user terminals, except that they are not provided with tuners. Additionally, the master user terminal is provided with monitoring software such as accounting, and the system supervisor computer is provided with a control interface to the A/V equipment in the A/V library as well as control software for controlling the A/V equipment. Furthermore, the system is provided with an A/V filer, an A/V device controller, and an analog A/V signal combiner.

While the system requires one less independent network and less costly custom equipment to accomplish the desired distribution, the system still has the following disadvantages:

- a) the users still cannot control the A/V sources;
- b) the user personal computers are still essentially turned into passive "TV monitors" when A/V materials are distributed to them, although superimposing of messages is possible, making the personal computers substantially unavailable for other more interactive concurrent usages;
- c) the A/V materials are still not capturable by the users as video and sound data inputs to other processing.
- d) screen images cannot be shared between a "control" station and a user personal computer, nor can keystrokes be provided from the "control" station to a user personal computer.

With the advent of multi-media computers, the industry trend is to provide systems with multi-media computers and digital A/V servers coupled to each other on a single digital data communication network. A/V materials are stored on the digital A/V servers in digitized form, and distributed through the digital data communication network. While these systems would overcome the disadvantages discussed above, these systems have the disadvantages of requiring the A/V materials to be available, stored, and distributed in digitized form, which typically also requires data compression and decompression at the transmission and

receiving ends. Notwithstanding data compression, the volume of digital video and sound data that have to be transmitted would put a heavy burden on the digital data communication network. Most of all, these systems are relatively expensive today.

As will be disclosed in more detail below, the present invention provides a cost effective approach to selectable A/V distribution to local and remote stations that advantageously achieves the above described and other desired results.

SUMMARY OF THE INVENTION

The desirable results are advantageously achieved by equipping a master control station as well as a number of local and/or remote stations with multi-media workstations having networking interfaces, multi-frequency analog video signal receivers, and various A/V software, and coupling these multi-media workstations to a number of A/V sources and each other via a multi-channel A/V network and a digital data network.

Preferably, the multi-channel A/V network is a cable television (CATV) network. For an embodiment adapted for local area usage, such as a classroom or a cluster of close by offices, preferably the digital data network is an Ethernet network.

In one embodiment, except for an modulated A/V source, each of the unmodulated A/V sources comprises an A/V device and a corresponding networkable modulator, coupled to each other. Additionally, the networkable modulators are serially coupled to each other with the last networkable modulator coupled to the head of the CATV network, and individually to the Ethernet network.

In an alternate embodiment, standard modulators in conjunction with an A/V signal combiner and an A/V device controller are

used instead. The modulated A/V sources and the standard modulators are connected to the A/V signal combiner which in turn is coupled to the head of the CATV network. The A/V devices are connected through corresponding interfaces to the A/V device controller which in turn is coupled to the master control multi-media workstation.

For either embodiments, each of the stations is provided with a multi-media workstation having a high performance processor, A/V digitization and rendering circuitry, a high pixel density display, and speakers. Each of the multi-media workstations is also equipped with a CATV tuner and an Ethernet interface. Additionally, each of the multi-media workstations is equipped with an operating system having integrated network and A/V services, an A/V command handler module, and an A/V control module. Lastly, the multi-media workstation for the master control station is further equipped with a master A/V control module.

Both the A/V control module and the master A/V control module include end-user interfaces for interacting with users of the multi-media workstations. Additionally, the A/V control module further includes a programming interface for interacting remotely with the master A/V control module, when the A/V control module is running on a multi-media workstation at a user station.

During operation, the user at the multi-media workstation with the master A/V control module selectably controls the A/V devices remotely through the end-user interface of the A/V control module. In response, the A/V devices generate A/V outputs, which in turn are modulated as analog A/V signals onto the different channels of the CATV network. The CATV network delivers the analog A/V signals to the multi-media workstations. The user at the multi-media workstation with the master A/V control module further selectably controls the A/V rendering control selections to be used by the A/V control modules on the other multi-media workstation remotely, through the end-user interface of the master A/V control module. Accordingly, the A/V control modules on the other multi-media workstations control the A/V signal receptions by the analog video signal receivers, and A/V signal digitization and rendering on the displays and speakers by the A/V digitization and rendering circuitry on their respective multi-media workstations.

Additionally, the user at the multi-media workstation with the master A/V control module may further selectably grant or revoke authorizations to access the A/V sources by users at the other multi-media workstations through the end-user interface of the master A/V control module. The users with granted authorization to access may further selectably control the A/V devices remotely through the end-user interfaces

of the A/V control modules running on their respective multi-media workstations.

Furthermore, the users at the other multi-media workstations may selectably control the A/V signals reception, digitization, and rendering at their respective multi-media workstations through the end-user interfaces of the A/V control modules on their respective multi-media workstations, provided the local control selections do not conflict with the remote control selections. In the event of conflicts, the remote control selections take precedent over the local control selections.

BRIEF DESCRIPTION OF THE DRAWINGS

Figures 1a & 1b illustrate two embodiments of the network of A/V devices and multi-media workstations of the present invention.

Figure 2 illustrates the relevant portions of the architecture of one embodiment of one of the multi-media workstations of **Figures 1a & 1b**.

Figure 3 illustrates the relevant software components on the multi-media workstations of **Figures 1a & 1b**.

Figure 4 illustrates an exemplary screen image rendered on the display of **Figure 2**.

Figure 5 illustrates some of the elements of one embodiment of the end user interface of the A/V control module of **Figure 3**.

Figure 6 illustrates one of the elements of one embodiment of the end user interface of the master A/V control module of **Figure 3**.

Figure 7 illustrates the method steps for selectable A/V distribution from the A/V devices to the multi-media workstations of **Figures 1a & 1b**.

DETAILED DESCRIPTION

In the following description for purposes of explanation, specific numbers, materials and configurations are set forth in order to provide a thorough understanding of the present invention. However, it will be apparent to one skilled in the art that the present invention may be practiced without the specific details. In other instances, well known systems are shown in diagrammatic or block diagram form in order not to obscure the present invention unnecessarily.

Referring now to **Figures 1a - 1b**, two block diagrams illustrating two embodiments of the network of A/V devices and multi-media workstations of the present invention are shown. As illustrated, the network **10** comprises a number of multi-media workstations **12** and **14**, and a number of A/V sources **16**. The multi-media workstations **12** and **14** are coupled to the A/V sources **16** and each other via a multi-channel A/V network **18**, and a digital data network **20**. Optionally, the network **10** may further comprise a number of other A/V presentation stations **22**, which are also coupled to the multi-channel A/V network **18** and the digital data network **20**.

It is contemplated that the multi-media workstations **12** and **14** are provided to a master control station and a number of local or remote

individual user stations, whereas the optional A/V presentation stations **22** are provided to multi-user stations. For some applications, such as computer aided classroom instruction, the multi-media workstations **12** and **14** are provided to a teacher and a number of individual student stations, and together with the A/V sources **16** and the optional A/V presentation stations **22** all located close to each other in the same or adjacent classrooms. On the other hand, for other applications, such as a business research and development facility, the multi-media workstations **12** and **14** are provided to a control station and a number of engineering/programming stations, and including the A/V sources **16** as well as the optional A/V presentation stations **22** all dispersed in remote offices and/or conference rooms throughout the facility.

Users perform computing and selectably receive A/V materials using their multi-media workstations **12** and **14**. As will be described in further detail below, each of the multi-media workstations **12** and **14** is equipped to selectably control the generation of the A/V materials by the A/V sources **16**, as well as selectably control the reception and rendering of the A/V materials on the workstation itself. The multi-media workstation **12** provided to the master control station is further equipped to selectably control the reception and rendering of A/V materials on the multi-media workstations **14** and the optional A/V presentation stations **22**.

The digital data network **20** delivers data including commands from the multi-media workstations **12** and **14** to the A/V sources **16**, between the multi-media workstations **12** and **14**, and from the master control station's multi-media workstation **12** to the optional presentation stations **22**. In an embodiment adapted to local area application, preferably the digital data network **20** is an Ethernet network.

The A/V sources **16** responsive to the controls of the multi-media workstations **12** and **14** generate and modulate the A/V materials as analog A/V signals onto the different channels of the multi-channel A/V network **18**. Depending on the implementation, the channel onto which an A/V source **16** is to modulate its generated analog A/V signals may be predetermined or under remote control from the multi-media workstations **12** and **14**.

As illustrated in the presently preferred embodiment in **Figure 1a**, the A/V sources **16** comprise a number of A/V device **24**, and a number of corresponding networkable modulators **26**. Optionally, the A/V sources **16** may further comprise a modulated A/V source **25** and a corresponding filter amplifier combination **27**. Each A/V device **24** is coupled to its corresponding networkable modulator **26**. The networkable modulators **26** are serially coupled to each other with the last of the networkable modulators **26** coupled to the head of the multi-channel

network 18. The networkable modulators 26 are also individually coupled to the digital data network 20. The optional filter amplifier combination 27 is coupled to the first of the networkable modulators 26. Preferably, each A/V device 24 is coupled to provide the corresponding networkable modulator 26 with its analog A/V outputs as well as to receive commands originated from the multi-media workstations 12 and 14 from its networkable modulator 26. An A/V device 24 not coupled to receive commands from its networkable modulator 26 may be operated manually.

In addition to the analog A/V outputs received from its corresponding A/V device 24, the first networkable modulator 26 also receives the modulated analog A/V signals on various frequencies from the modulated A/V source 25. The first networkable modulator 26 modulates the analog A/V outputs received from its corresponding A/V device 24 onto a predetermined or remotely instructed unused frequency and combining them with the other modulated analog A/V signals before outputting them. Similarly, each subsequent networkable modulator 26 receives the analog A/V outputs from its corresponding A/V device 24, and modulated analog A/V signals on various frequencies from its predecessor networkable modulator 26. In like manner, each subsequent networkable modulator 26 modulates the analog A/V output received from its corresponding A/V device 24 onto a predetermined or remotely instructed unused frequency and combining them with the other modulated analog A/V signals before

outputting them. Thus, the analog A/V signals on the various frequencies are placed onto the multi-frequency network **18**.

Particular examples of A/V devices **24** include but not limited to video cameras, video cassette recorders (VCRs), and video disc players (VDP) known in the art, modified with an interface to accept commands from the networkable modulators **26**. The networkable modulators **26** may be implemented with modulators known in the art, modified to incorporate a digital data network interface for connection to the digital data network **20** and an interface for connecting to the A/V device **24**. Particular examples of a modulated A/V source **25** includes but not limited to a television (TV) antenna, a satellite TV dish, and a cable TV provider. Particular examples of an A/V presentation station **22** include but not limited to an A/V projector.

As illustrated in the alternate embodiment in **Figure 1b**, standard modulators **28** in conjunction with an A/V signal combiner **30** and an A/V device controller **32** may be used in lieu of networkable modulators **26**. The modulated A/V source **27** and the standard modulators **28** are connected to the A/V signal combiner **30** which in turn is coupled to the multi-channel network **18**. Additionally, the A/V devices **24** are preferably connected through corresponding interfaces to the A/V device controller **32** which in turn is coupled to the master control station's multi-media workstation **12**.

A particular example of the standard modulators **28** is the A/V modulator, model #VM2552, manufactured by R.L. Drake Co., Miamisburg, Ohio. A particular example of the A/V signal combiner **30** is the A/V signal combiner, model OC-12, manufactured by Olson Technology, Inc., Sierra Village, Ca. A particular example of the A/V device controller **32** is the A/V device controller ALIX, manufactured by VideoMedia, San Jose, Ca.

The multi-channel A/V network **18** delivers the analog A/V signals from the A/V sources **16** to the multi-media workstations **12** and **14**, and the optional A/V presentation stations **22**. Preferably, the multi-channel A/V network **18** is a CATV network.

The embodiment illustrated in **Figure 1a** has more flexibility in that it allows users at the multi-media workstations **12** and **14** to dynamically change the frequencies on which the networkable modulators **26** modulate the outputs of the A/V devices **24**. However, the embodiment illustrated in **Figure 1b** is probably less costly and simpler to implement. Additionally, while both embodiments illustrate the master control station as being also provided with a multi-media workstation, based on the descriptions to follow, it will be appreciated that the present invention may be practiced without the master control station being provided with the

capability of digitizing analog A/V signals into digitized video and sound data.

*Referring now to **Figure 2**, a block diagram illustrating the relevant portions of the architecture of one embodiment of the teacher and student multi-media workstations **12** and **14** is shown. As illustrated, in this embodiment, each of the multi-media workstations **12** and **14** comprises a central processing unit (CPU) **100**, A/V digitization circuitry **102**, read only memory (ROM) **104**, random access memory (RAM) **106**, video memory (VRAM) **108**, and a number of permanent storage devices **110**. Additionally, each of the multi-media workstations **12** and **14** comprises a system bus **128**, an A/D and D/A converter **130**, a digital data network interface **116**, a multi-channel analog A/V signal receiver **118**, and a display controller **124**. Furthermore, each of the multi-media workstations **12** and **14** comprises a keyboard **112**, a cursor control device **114**, a microphone **120**, speakers **122**, and a display **126**. These elements **100** - **130** are coupled to each other as shown.*

The CPU **100** and the A/V digitization and rendering circuitry **102** are preferably high performance processor and circuitry complemented with memories **104** - **108** of sufficiently large capacity to support high performance and high volume processing of multi-media data for rendering of TV-like full motion picture image sequences on the display **126** and high

quality sound on the speakers **122**. The storage devices **120** preferably include a hard disk and a CD-ROM drive. For an embodiment adopted for local area application, the digital data network interface **116** is preferably an Ethernet interface. The multi-channel analog signal receiver **130** is preferably a CATV tuner. The speakers **122** preferably include a pair of stereo speakers and headphone connectors. The display **126** preferably is a high density pixel display, and the display controller **124** is complementarily adapted.

The multi-channel analog signal receiver **130** receives analog A/V signals from one of the channels of the multi-channel network **18**. The A/D and D/A converters **130** digitizes the received analog audio signals into digitized audio data, and stores the digitized audio data into the RAM **106**. The A/V digitization and rendering circuitry **102** digitizes the received analog video signals into digitized video data, and stores the digitized video data into the VRAM **108**. The stored digitized audio data are rendered as sound on the speakers **122** through the A/D and D/A converter **130** under program control. The stored digitized video data are rendered as TV-like full motion picture image sequence on the display **126** through the display controller **124** under program control.

In the presently preferred embodiment, the digitized audio and video data are stored into the RAM **106** and VRAM **108** cumulatively,

and the stored audio and video data are rendered as sound on the speakers **122**, and TV-like full motion picture image sequence on the display **126** real time.

A particular example of a multi-media workstation comprising these elements **100 - 130** is the Quadra 660 A/V computer manufactured by Apple Computer, Inc. of Cupertino, Ca. (hereinafter as Apple), modified to include the multi-channel analog signal receiver **118**. Alternatively, the multi-media workstation **12** or **14** may be implemented with a Macintosh LC computer, also manufactured by Apple, enhanced to include the speakers **122**, the multi-channel analog A/V signal receiver **118**, as well as a peripheral card having the A/V digitization circuitry **102**.

The multi-channel analog signal receiver **118** may be implemented with any number of multi-channel analog signal receivers known in the art, modified to complement the particular implementations of the multi-channel A/V network **18** and the other elements **100 - 130** of the multi-media workstations **12** and **14**.

Referring now to **Figure 3**, a block diagram illustrating the relevant software components on the multi-media workstations **12** and **14** is shown. As illustrated, each of the multi-media workstations **12** and **14** is equipped with an operating system having integrated network and A/V

services **200**, an A/V command handler module **202** and an A/V control module **206**. The master control station's multi-media workstation **12** is further equipped with a master A/V control module **210**.

As will be described in further detail below, both the A/V control module **206** and the master A/V control module **210** include end-user interfaces for interacting with users at the multi-media workstations **12** and **14**. Additionally, the A/V control module **206** further comprises a programming interface for interacting remotely with the master A/V control module **210** when running on user stations' multi-media workstations **14**.

In addition to the A/V services necessary to control the A/V digitization circuitry **102**, and the display control **124**, preferably the operating system **200** includes A/V services for capturing digitized audio and video data as inputs for other processing, such as video editing, or creating a multi-media report. A particular example of an operating system having integrated network and A/V services is System 7 (including the Quicktime system extension) designed for the Macintosh computers developed by Apple.

The A/V command handler module **202** takes the commands generated by the A/V control module **206** and the master A/V control module **210**, formulates them into data packets adapted for transmission

by the underlying operating system network services **200** over the digital data network **20**, and calls the operating system network services **200** to transmit them. The generated commands may be directed to all or selected ones of the nodes of the network. A node may be a multi-media workstation **12** and **14**, one of the A/V sources **16**, or one of the optional A/V presentation stations **22**.

The A/V command handler module **202** may be implemented in any number of programming languages and techniques similar to many low level data communication handlers found in other applications. The implementation is dependent on the functions to be supported by the A/V command handler module **202**, and the network services provided by the underlying operating system **200**. For further information on network services supported by System 7, see Inside Macintosh, Vol I - VI, published by Addison Wesley, 1985 - 1991.

The A/V control module **206** responsive to a user's interactions with its end user interface generates commands directing the multi-channel analog A/V signal receiver **118** on its multi-media workstation **12** and **14** to receive analog A/V signals from one of the channels of the multi-channel network **18**. The A/V control module **206** responsive to the user's interactions with its end user interface further generates commands directing the A/D and D/A converter **130** and the A/V

digitization circuitry **102** on its multi-media workstation **12** and **14** to digitize the received analog audio and video signals into digital audio data and digital video data with particular scaling, horizontal and vertical filtering respectively. Lastly, the A/V control module **206** responsive to the user's interactions with its end user interface further generates commands directing the A/D and D/A converter **130** and the display controller **124** to render the digitized audio data as sound on the speakers **122** having particular audio characteristics, and the digitized video data as TV-like full motion image sequence on the display **125** having particular video characteristics.

The A/V control module **206** further performs the above described functions responsive to remote commands received from the master A/V control module over the digital data network **20** through the A/V command handler modules **202** and the operating systems **200** on the respective multi-media workstations **12** and **14**. In the event that the remote commands conflict with the user interactions, the remote commands take precedence over the user interactions. Preferably, the A/V control module **206** responsive to remote commands further disables incompatible user control selections in its end user interface. Additionally, the A/V control module **206** responsive to the user's interactions with its end user interface further generates commands directing the remote A/V sources **16** to generate and modulate A/V materials as A/V analog signals on various

frequencies on the multi-channel A/V network **18**, when the A/V control module **206** is granted authorization to access the A/V sources **16**, thereby allowing the users at the other multi-media workstations **14** to directly control the A/V sources **16**. Preferably, the A/V control supported includes but not limited to starting, stopping, forwarding, rewinding an A/V title.

The A/V control module **206** may be implemented in any number of programming languages and technique similar to many control modules found in other applications. Except for the programming interface, acceptance of remote commands through the programming interface, the prioritization of these remote commands over local user interactions, the dependency of the available user actions on the end user interface on the remote commands, and remotely controlling the A/V sources, the basic functions of the A/V control module **206** is known to have been implemented for at least the MacTV product manufactured by Apple. Implementation of the noted additional functionalities is well within the ability of those skilled in the art. Thus, except for the manner in which the A/V control module **206** cooperates with other elements under the teachings of the present invention, the A/V control module **206** will not be otherwise further described.

The master A/V control module **210** responsive to a user's interactions with its end user interface generates commands directing the

remote A/V sources **16** to generate and modulate A/V materials as A/V analog signals on various frequencies on the multi-channel A/V network **18**. Preferably, the control supported includes but not limited to the starting, stopping, forwarding, and rewinding of an A/V title. The master A/V control module **210** responsive to the user's interactions with its end user interface further generates commands directing the A/V control modules **206** on other multi-media workstations **12** and **14** as to how to direct the multi-channel analog A/V signal receivers **118**, the A/D and D/A converters **130**, the A/V digitization circuitry **102**, and the display controllers **124** on these multi-media workstations **12** and **14** to receive analog A/V signals from one of the channels of the multi-channel network **18**, to digitize the received analog audio and video signals into digital audio data and digital video data, to render the digitized audio and video data as sound and TV-like full motion image sequence on the speakers **122** and the display **125**.

Preferably, the master A/V control module **210** responsive to the user's interactions with its end user interface further generates commands granting or revoking access to the A/V sources **16** to selected ones of the other multi-media workstations **14**.

The master A/V control module **210** may be implemented in any number of programming languages and techniques similar to many remote control modules found in other applications. The implementation is

dependent on the functions supported by the master A/V control module **210**.

Still referring to **Figure 3**, as illustrated, in this embodiment, in addition to the A/V services provided by the operating system **200**, each of the multi-media workstations **12** and **14** is further provided with an audio distribution module **204**, and a number of A/V applications **208**.

The audio distribution module **204**, when running on the master control station's multi-media workstation **12**, responsive to commands generated by the master A/V control module **210** generates commands for the audio services of the operating system **200**, directing the network and audio services to establish channels of audio communications between the master control station's multi-media workstation **12** and selected ones of the other multi-media workstations **14**. Additionally, the audio distribution module **204** on an audibly connected multi-media workstation **12** and **14** causes audio data digitized from analog audio inputs received from the microphone **120** to be packaged and transmitted to the appropriate ones of the other multi-media workstations **12** and **14** over the digital data network **20**. Furthermore, the audio distribution module **204** on an audibly connected multi-media workstation **12** and **14** causes the digitized audio data received over the digital data network **20** to be rendered on the speakers **122**.

The audio distribution module **204** may be implemented in any number of programming languages and techniques similar to many low level sound handlers found in other applications. The implementation is dependent on the functions to be supported by the audio distribution module **204**, and the audio services provided by the underlying operating system **200**. For further information on audio services supported by System 7, see Inside Macintosh, Vol I - VI, published by Addison Wesley, 1985 - 1991.

The A/V applications **208** include an A/V application for screen sharing, and one multi-media workstation **12** providing its keystroke and cursor control inputs to another multi-media workstation **14** over the digital data network **20** through the network services of the underlying operating system **200**. A particular example of such an A/V application is the Timbuktu product developed by Farallon Computing, Inc., of Alameda, Ca.

The master A/V control module **210** responsive to the user's interactions with its end user interface further generates commands for the audio distribution module **204** and the A/V applications **208**, causing these module/application **204** and **208** to establish and effectuate audio communication with all or selected ones of the other multi-media

workstations **14**, to show the current screen content rendered on its multi-media workstation's display **126** on the displays **126** of selected ones of the other multi-media workstations **14**, to show the screen images being rendered on the display **126** of a selected one of the other multi-media workstations **14** to be shown on its multi-media workstation's display **126**, and to provide the input keystrokes and cursor controls from its multi-media workstation's keyboard **112** and cursor control **114** to selected ones of the other multi-media workstations **14**.

Additionally, the A/V control module **206** responsive to the user's interactions with its end user interface further generates commands for the video capturing services of the operating system **200** causing the digitized video data to be captured into a data file, which in turn can be used as inputs to a variety of other processing.

Referring now to **Figure 4**, a diagram illustrating an exemplary screen image rendered on the display **124** of **Figure 2** is shown. As illustrated, the screen image **300** comprises a number of resizable display windows **302 - 306** for displaying information for different programs. For the exemplary screen image **300** illustrated, one of the display window **302** is used to render the digitized video data as TV-like full motion image sequence. The other two display windows **304** and **306** are used to display information for the operating system **200**. As

illustrated by the display window **306**, the user can continue to interact with an application or the operating system, while the digitized video data are being rendered as TV-like full motion image sequence. Thus, under the present invention, the multi-media workstations **12** and **14** remain active and useable when A/V materials are selectably distributed to them.

Referring now to **Figure 5**, a diagram illustrating some of the elements of one embodiment of the end user interface of the A/V module **206** is shown. As illustrated, the end user interface **310** comprises a video control window **310** and an audio control window **312**. Additionally, the end user interface **310** comprises the video display window **302** illustrated in **Figure 4**. Furthermore, in this embodiment, the end user interface **310** comprises an A/V device control window **314** and an A/V capture control window **316**. The windows **302**, and **310 - 316** are selectively displayed depending on the received remote commands, and the local user interactions with the end user interface **308** of the A/V control module **206**.

The image display window **302** (see **Fig. 4**) is resizable and includes icons for a user to change channel and audio volume. As described earlier, responsive to interactions with these icons, the A/V control module **206** generates appropriate commands for the A/V digitization circuitry **102**, the display controller **124**, and the A/D and D/A converter **130**.

The video control window **310** includes icons for a user to select the video type, change the brightness, sharpness, and tint of the video images, etc. As described earlier, responsive to interactions with these icons, the A/V control module **206** generates appropriate commands for the display controller **124**.

The audio control window **312** includes icons for a user to select the audio type, change the balance, bass, and treble of the sound rendered, etc. As described earlier, responsive to interactions with these icons, the A/V control module **206** generates appropriate commands for the A/D and D/A converter **130**.

The A/V device control window **314** includes icons for a user to control an A/V source **16**, such as playing an A/V title, stop playing an A/V title, fast forwarding, etc. As described earlier, responsive to interactions with these icons the A/V control module **206** generates appropriate commands for the A/V command handler module **202** to format and forward to the A/V source **16** through the operating system **200** and the digital data network **20**.

The A/V capturing control window **314** includes icons for a user to control capturing of digitized video and sound data. As described

earlier, responsive to interactions with the icons, the A/V control module **206** generates appropriate commands for the A/V capturing application **208**.

The end user interface **308** may be implemented with any number of programming languages and techniques. The implementation is dependent on the amount of control functions supported. As will be appreciated, in addition to the control functions illustrated, the end user interface **308** of the A/V control module **206** may support a variety of other control functions. For further information on implementing windowed graphical end user interface under System 7, see also Inside Macintosh, Vol I - VI, published by Addison Wesley, 1985 - 1991.

Referring now to **Figure 6**, a diagram illustrating one of the elements of one embodiment of the end user interface of the master A/V control module **210** is shown. As illustrated, the end user interface **320** comprises a base control window **322**. The base control window **322** includes a "show video" icon and related dialog boxes (not shown) for a user to instruct all or selected ones of the other multi-media workstations **14** and the optional presentation stations **22** to receive analog video signals of an A/V materials off a particular channel of the multi-channel A/V network **18**. As described earlier, responsive to interactions with the icon and its related dialog boxes, the master A/V control module **210** generates

appropriate commands for the A/V command modules **206** at the selected multi-media workstations **14** through the A/V command handler modules **202**, the operating systems **200**, and the digital data network **20**.

The base control window **322** further includes a "show screen" icon, a "control" icon, and their related dialog boxes (not shown) for a user to show his/her screen content, and provide his/her keystrokes/cursor controls to all or selected ones of the other multi-media workstations **14**. As described earlier, responsive to interactions with these icons and their related dialog boxes, the master A/V control module **210** generates commands for one of the A/V application **208** on its multi-media workstation **12**, which in turn cooperates with the A/V applications **208** on the selected multi-media workstations **12** to accomplish the desired results.

The base control window **322** further includes an "observe" icon and its related dialog boxes (not shown) for a user to observe the screen content of a selected one of the other multi-media workstations **14**. As described earlier, responsive to interactions with the icon and its related dialog boxes, the master A/V control module **210** generates commands for one of the A/V application **208** on its multi-media workstation **12**, which in turn cooperates with the A/V applications **208** on the selected multi-media workstations **12** to accomplish the desired results.

The base control window **322** further includes an "announce" icon, a "talk" icon, and their related dialog boxes (not shown) for a user to establish and conduct audio communication with all or selected ones of the other multi-media workstations **14**. As described earlier, responsive to interactions with these icons and their related dialog boxes, the master A/V control module **210** generates commands for the A/V audio distribution module **204** on its multi-media workstation **12**, which in turn cooperates with the A/V distribution module **204** on the selected multi-media workstations **12** to accomplish the desired results.

Lastly, the base control window **322** further includes a "grant" icon (not shown) and related dialog boxes (also not shown) for a user to grant or revoke authorization to access particular A/V sources **16**. . As described earlier, responsive to interactions with the icon and its related dialog boxes, the master A/V control module **210** generates appropriate commands for the A/V command modules **206** at the selected multi-media workstations **14** through the A/V command handler modules **202**, the operating systems **200**, and the digital data network **20**.

The end user interface **320** may be implemented with any number of programming languages and techniques. The implementation is dependent on the amount of control functions supported. As will be appreciated, in addition to the basic control functions illustrated, the end

user interface **320** of the master A/V control module **210** may support a variety of other control functions also.

Referring now to **Figure 7**, a block diagram illustrating the method steps for selectable A/V distribution to local or remote station is shown. As illustrated, during operation, the users selectably control the A/V devices **24** remotely through the end-user interfaces **308** of the A/V control modules **206** running on their respective multi-media workstations **12** and **14**, **step 402**. As described earlier, the users at the other multi-media workstations **14** may selectably control the A/V devices **24** if they are granted authorization to access these A/V devices **24** by the user at the multi-media workstation **12** provided to the master control station. Responsive to these user actions, the A/V control modules **206** generate A/V commands which are routed to the A/V devices **24** through the A/V command handler modules **202**, the operating systems **200**, and the digital data network **20**.

In response, the A/V devices **24** generate A/V outputs, which in turn are modulated onto the different channels of the multi-channel network **18**, **step 404**. The multi-channel network **18** delivers the analog A/V signals to the multi-media workstations **12** and **14**.

The users control the A/V signals reception, their digitization and rendering on their respective multi-media workstations **12** and **14** through the end-user interfaces **308** of the A/V control modules **206** running on their respective multi-media workstations **12** and **14**, **step 406**. Additionally, the user at the multi-media workstation **12** provided to the master control station may further selectably override the A/V control selections made by a user at one of the other multi-media workstations **14** through the end user interface of the master A/V control module **210**.

The A/V control module **206** sets the multi-channel analog A/V signal receiver **118** on its multi-media workstation **12** or **14** to the appropriate channel, causes the A/D and D/A converter **130** and the A/V digitization circuitry **102** to digitize the analog audio and video signals into digital audio and video data, and the A/D and D/A converter **130** and the display controller **124** to render the digital audio and video data sound on the speakers and TV-like full motion picture image sequence in a resizable window on the display **126** of the multi-media workstation **12** or **14** accordingly, **step 408**.

While the present invention has been described in terms of presently preferred and alternate embodiments, those skilled in the art will recognize that the invention is not limited to the embodiments described. The method and apparatus of the present invention can be practiced with

modification and alteration within the spirit and scope of the appended claims. The description is thus to be regarded as illustrative instead of limiting on the present invention.

WHAT IS CLAIMED IS

1. An apparatus for selectable audio/video (A/V) delivery to at least one multi-media workstation comprising:
 - a) an A/V source for generating and modulating a first A/V material as a first stream of analog A/V signals on a first frequency channel;
 - b) an A/V network coupled to said A/V source for conveying said first stream of analog A/V signals on said first frequency channel;
 - c) a first multi-media workstation comprising a first analog A/V signal receiver coupled to said A/V network for receiving said first stream of analog A/V signals off said first frequency channel in response to first A/V rendering control commands, said first multi-media workstation further comprising a first A/V control module for providing said first analog A/V signal receiver with said first A/V rendering control commands in response to second A/V rendering control commands that are selectably provided, said first multi-media workstation in real time digitizing said first stream of analog A/V signals into a first stream of digital A/V data and rendering said first stream of digital A/V data as video images and sound on said first multi-media workstation;
 - d) a digital data network coupled to said first multi-media workstation for conveying said selectably provided second A/V rendering control commands to said first multi-media workstation; and

e) a remote A/V distribution controller coupled to said digital data network comprising a second A/V control module for selectably providing said second A/V rendering control commands and placing them onto said digital data network.

2. The apparatus as set forth in claim 1, wherein, said A/V source comprises:

(a.1) a first A/V device responsive to first A/V generation control commands selectably provided by said second A/V control module of said remote A/V distribution controller for generating said first A/V material as said first stream of analog A/V signals; and

(a.2) a first modulator coupled to said digital data network, said first A/V device, and said A/V network for routing said first A/V generation control commands from said remote A/V distribution controller to said first A/V device, and for modulating said first stream of analog A/V signals onto said A/V network on said first frequency channel, said first A/V control commands being provided to said first modulator through said digital data network.

3. The apparatus as set forth in claim 2, wherein said A/V source further comprises:

(a.3) a second A/V device responsive to second A/V generation control commands selectably provided by said second A/V control module

of said remote A/V distribution controller for generating a second A/V material as a second stream of analog A/V signals; and

(a.4) a second modulator coupled to said digital data network, said second A/V device, and said A/V network for routing said second A/V generation control commands from said remote A/V distribution controller to said second A/V device, and for modulating said second stream of analog A/V signals onto said A/V network on a second frequency channel, said second A/V generation control commands being provided to said second modulator through said digital data network.

4. The apparatus as set forth in claim 1, wherein,
said A/V network is a cable television (CATV) network;
said first analog A/V signal receiver is a CATV tuner; and
said first multi-media workstation render said video images and sound in a format and at a sufficiently fast rate such that said first A/V material appear like full motion television picture with corresponding sound track to a viewer at said second multi-media workstation.

5. The apparatus as set forth in claim 1, wherein,
said local area data network is an Ethernet network; and
each of said remote A/V distribution controller and first multi-media workstations comprises an Ethernet interface.

6. The apparatus as set forth in claim 1, wherein said apparatus further comprises:

f) a second multi-media workstation comprising a second analog A/V signal receiver coupled to said A/V network for receiving said first stream of analog A/V signals off said first frequency channel in response to third A/V rendering control commands, said second multi-media workstation further comprising a third A/V control module for providing said second analog A/V signal receiver with said third A/V rendering control commands in response to fourth A/V rendering control commands that are selectably provided, said second multi-media workstation in real time digitizing said first stream of analog A/V signals into a first stream of digital A/V data and rendering said first stream of digital A/V data as video images and sound on said second multi-media workstation.

7. The apparatus as set forth in claim 1, wherein said remote A/V distribution controller is a second multi-media workstation.

8. A computer implemented method for selectable audio/video (A/V) delivery to at least one multi-media workstation, said method comprising the steps of:

a) generating a first A/V material as a first stream of A/V analog signals, and modulating said first stream of A/V signals onto a first

frequency channel of an A/V network using an A/V device connected to the A/V network;

b) remotely and selectably generating first A/V rendering control commands, and placing said first A/V rendering control commands onto a digital data network using a remote A/V distribution controller connected to said digital data network;

c) receiving said first stream of A/V analog signals off said first frequency channel, digitizing said received first stream of analog A/V signals into a first stream of digital video and audio data, and rendering in real time said first stream of digital video and audio data as video images and sound, in accordance to said selectably generated first A/V rendering control commands, using a first multi-media workstation connected to said A/V network and said digital data network.

9. The method as set forth in claim 8, wherein,

said step (a) further comprises remotely and selectably generating first A/V generation control commands, and placing said first A/V generation control commands onto said digital data network, using said remote A/V distribution controller;

said A/V device being also connected to said digital data network generates said first A/V material as said first streams of analog A/V signals, and modulate said first stream of analog A/V signals onto said first

frequency channel in accordance to said selectably generated first A/V generation control commands.

10. The method as set forth in claim 8, wherein,
- said step a) further comprises generating a second A/V material as a second stream of A/V analog signals, and modulating said second stream of A/V signals onto a second frequency channel of said A/V network using said A/V device;
 - said step b) further comprises remotely and selectably generating second A/V rendering control commands, and placing said second A/V rendering control commands onto said digital data network using said remote A/V distribution controller;
 - said step c) further comprises receiving said second stream of A/V analog signals off said second frequency channel, digitizing said received second stream of analog A/V signals into a second stream of digital video and audio data, and rendering in real time said second stream of digital video and audio data as video images and sound, in accordance to said selectably generated second A/V rendering control commands, using a second multi-media workstation connected to said A/V network and said digital data network.

11. A computer aided instruction system comprising:

- a) an A/V source for generating and modulating a first A/V material as a first stream of analog A/V signals on a first frequency channel;
- b) an A/V network coupled to said A/V source for conveying said first stream of analog A/V signals on said first frequency channel;
- c) a first student multi-media workstation comprising a first analog A/V signal receiver coupled to said A/V network for receiving said first stream of analog A/V signals off said first frequency channel in response to first A/V rendering control commands, said first student multi-media workstation further comprising a first A/V control module for providing said first analog A/V signal receiver with said first A/V rendering control commands in response to second A/V rendering control commands that are selectably provided, said first student multi-media workstation in real time digitizing said first stream of analog A/V signals into a first stream of digital A/V data and rendering said first stream of digital A/V data as video images and sound on said first student multi-media workstation;
- d) a digital data network coupled to said first student multi-media workstation for conveying said selectably provided second A/V rendering control commands to said first student multi-media workstation; and
- e) a teacher station coupled to said digital data network comprising a second A/V control module for selectably providing said second A/V rendering control commands and placing them onto said digital data network.

12. The computer aided instruction system of claim 11, wherein,
said first A/V source generates and modulates said first A/V material as said first stream of analog A/V signals onto said first frequency channel in response to first A/V generation control commands that are selectably provided;

said second A/V control module of said teacher station further selectably generates said first A/V generation control commands; and

said digital data network further couples said first A/V source to said teacher station for delivering said first A/V generation control commands from said teacher station to said first A/V source.

13. The computer aided instruction system of claim 11, wherein, said system further comprises:

f) a second A/V source coupled to said A/V network for generating and modulating a second A/V material as a second stream of analog A/V signals onto a second frequency channel on said A/V network;

g) a second student multi-media workstation comprising a second analog A/V signal receiver coupled to said A/V network for receiving said second stream of analog A/V signals off said second frequency channel in response to third A/V rendering control commands, said second student multi-media workstation further comprising a third A/V control module for providing said second analog A/V signal receiver with said third A/V rendering control commands in response to fourth A/V rendering control

commands selectably provided by said second A/V control module of said teacher station, said second student multi-media workstation in real time digitizing said second stream of analog A/V signals into a second stream of digital A/V data and rendering said second stream of digital A/V data as video images and sound on said second student multi-media workstation.

14. An audio video (A/V) system comprising:

- a) an A/V source for generating and modulating a first A/V material as a first stream of analog A/V signals on a first frequency channel;
- b) an A/V network coupled to said A/V source for conveying said first stream of analog A/V signals on said first frequency channel;
- c) a first A/V station comprising a first analog A/V signal receiver coupled to said A/V network for receiving said first stream of analog A/V signals off said first frequency channel in response to first A/V rendering control commands, said first A/V station further comprising a first A/V control module for providing said first analog A/V signal receiver with said first A/V rendering control commands in response to second A/V rendering control commands that are selectably provided, said first A/V station in real time digitizing said first stream of analog A/V signals into a first stream of digital A/V data and rendering said first stream of digital A/V data as video images and sound on said first A/V station;

d) a digital data network coupled to said first A/V station for conveying said selectably provided second A/V rendering control commands to said first A/V station; and

e) a master station coupled to said digital data network comprising a second A/V control module for selectably providing said second A/V rendering control commands and placing them onto said digital data network.

15. The A/V system of claim 14, wherein,

said first A/V source generates and modulates said first A/V material as said first stream of analog A/V signals onto said first frequency channel in response to first A/V generation control commands that are selectably provided;

said second A/V control module of said master station further selectably generates said first A/V generation control commands; and

said digital data network further couples said first A/V source to said master station for delivering said first A/V generation control commands from said master station to said first A/V source.

16. The A/V system of claim 14, wherein, said system further comprises:

f) a second A/V source coupled to said A/V network for generating and modulating a second A/V material as a second stream of analog A/V signals onto a second frequency channel on said A/V network;

g) a second A/V station comprising a second analog A/V signal receiver coupled to said A/V network for receiving said second stream of analog A/V signals off said second frequency channel in response to third A/V rendering control commands, said second A/V station further comprising a third A/V control module for providing said second analog A/V signal receiver with said third A/V rendering control commands in response to fourth A/V rendering control commands selectably provided by said second A/V control module of said master station, said second A/V station in real time digitizing said second stream of analog A/V signals into a second stream of digital A/V data and rendering said second stream of digital A/V data as video images and sound on said second A/V station.

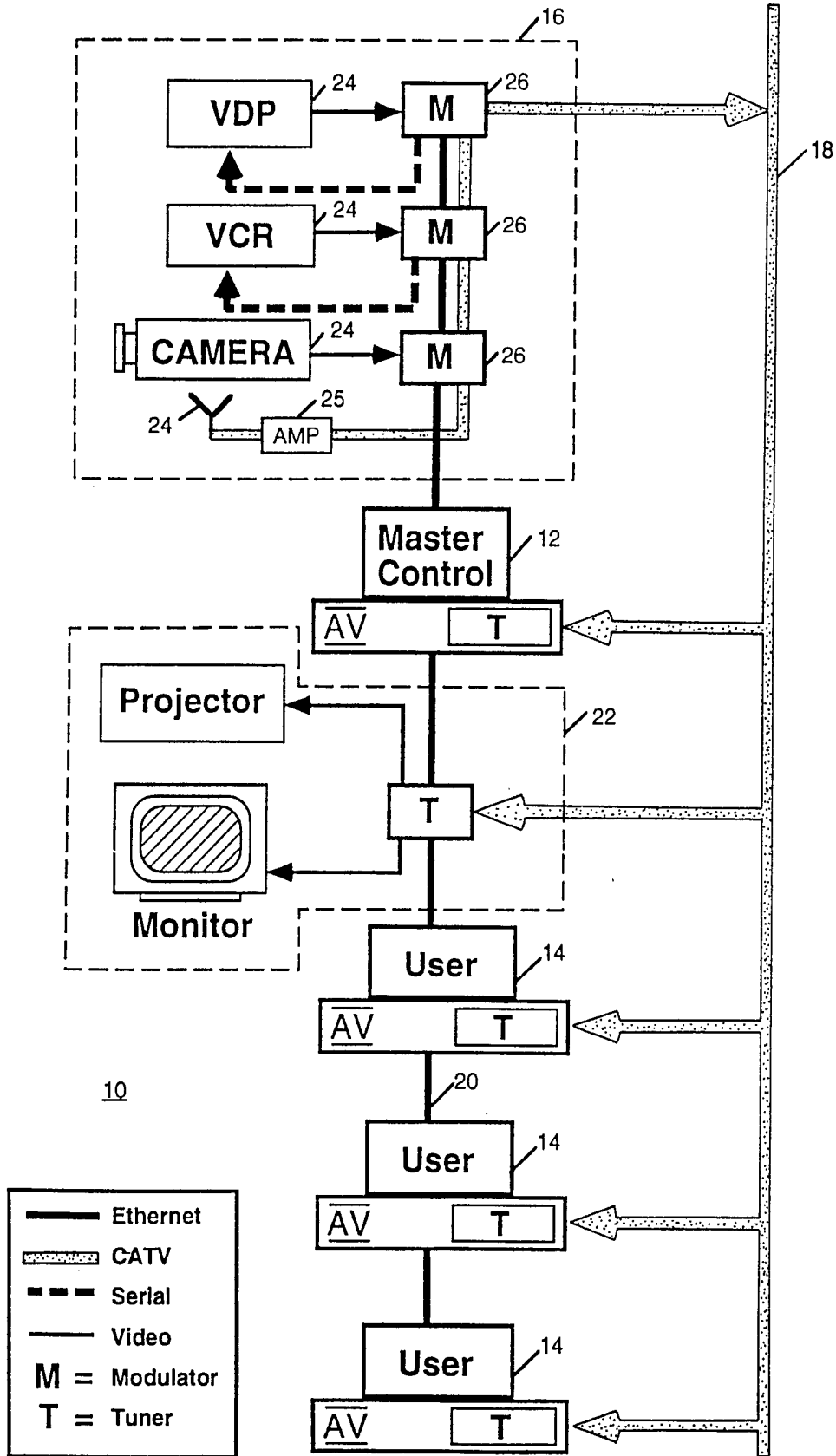

FIG. 1A

2 / 8

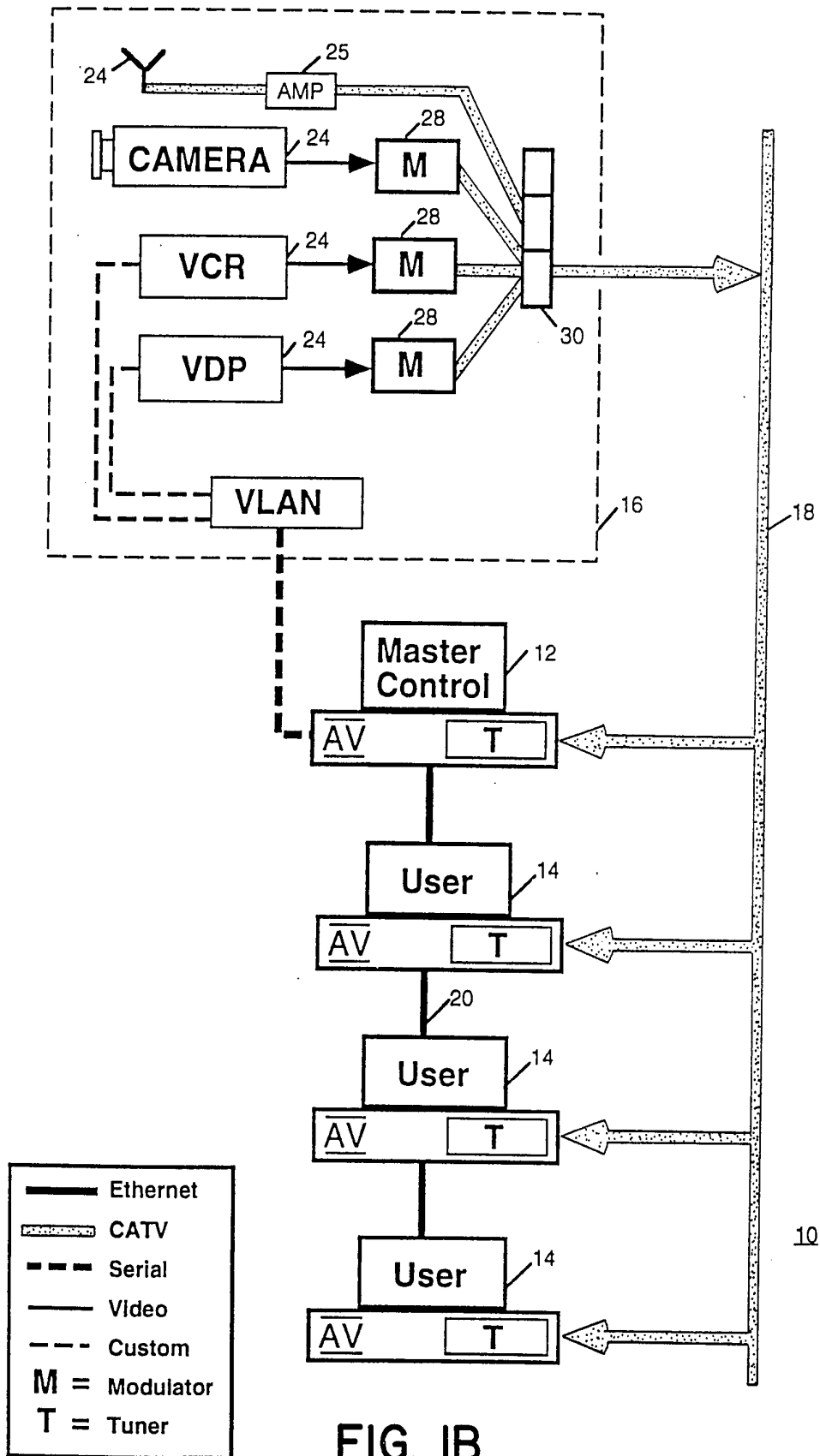

FIG. 1B

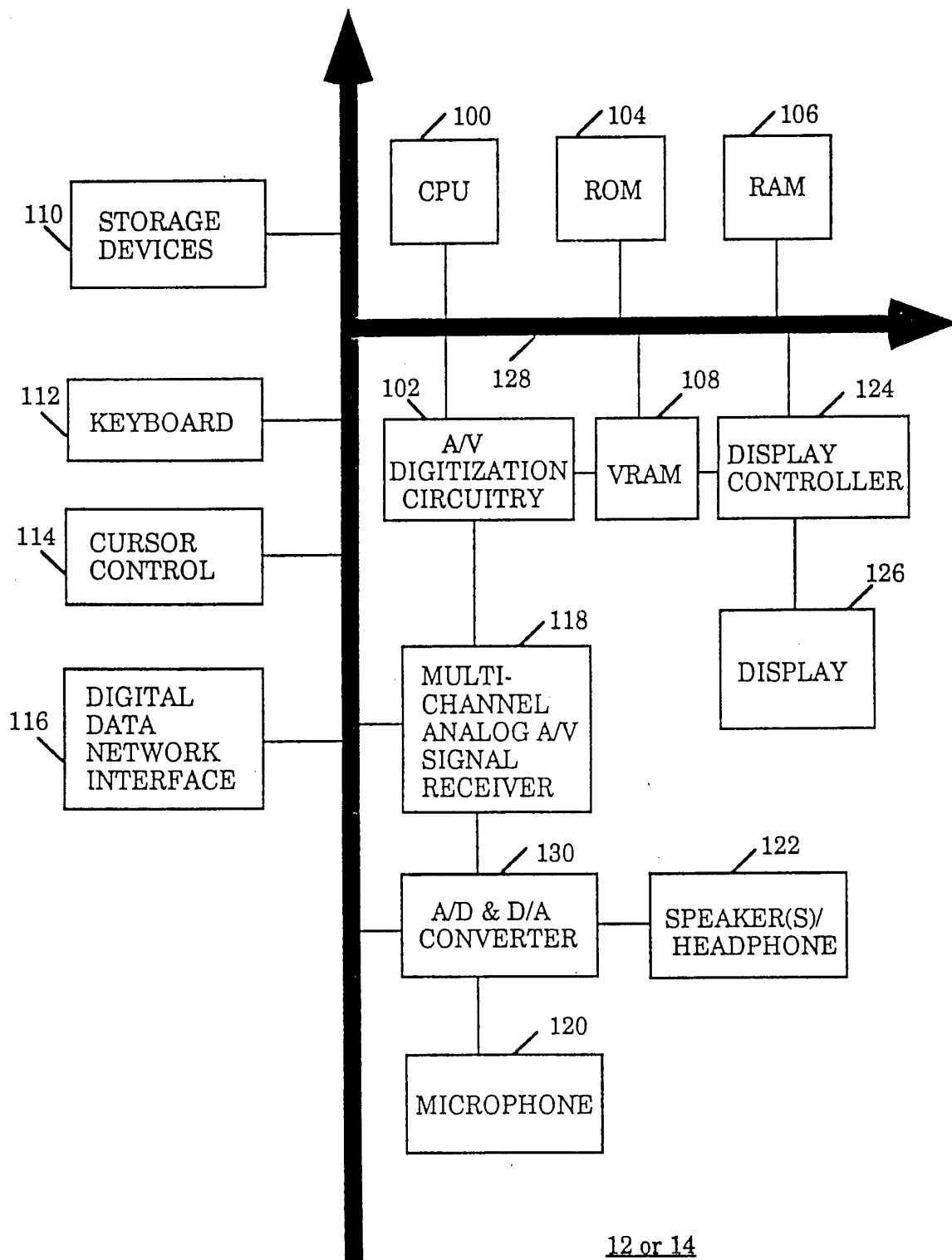

FIG. 2

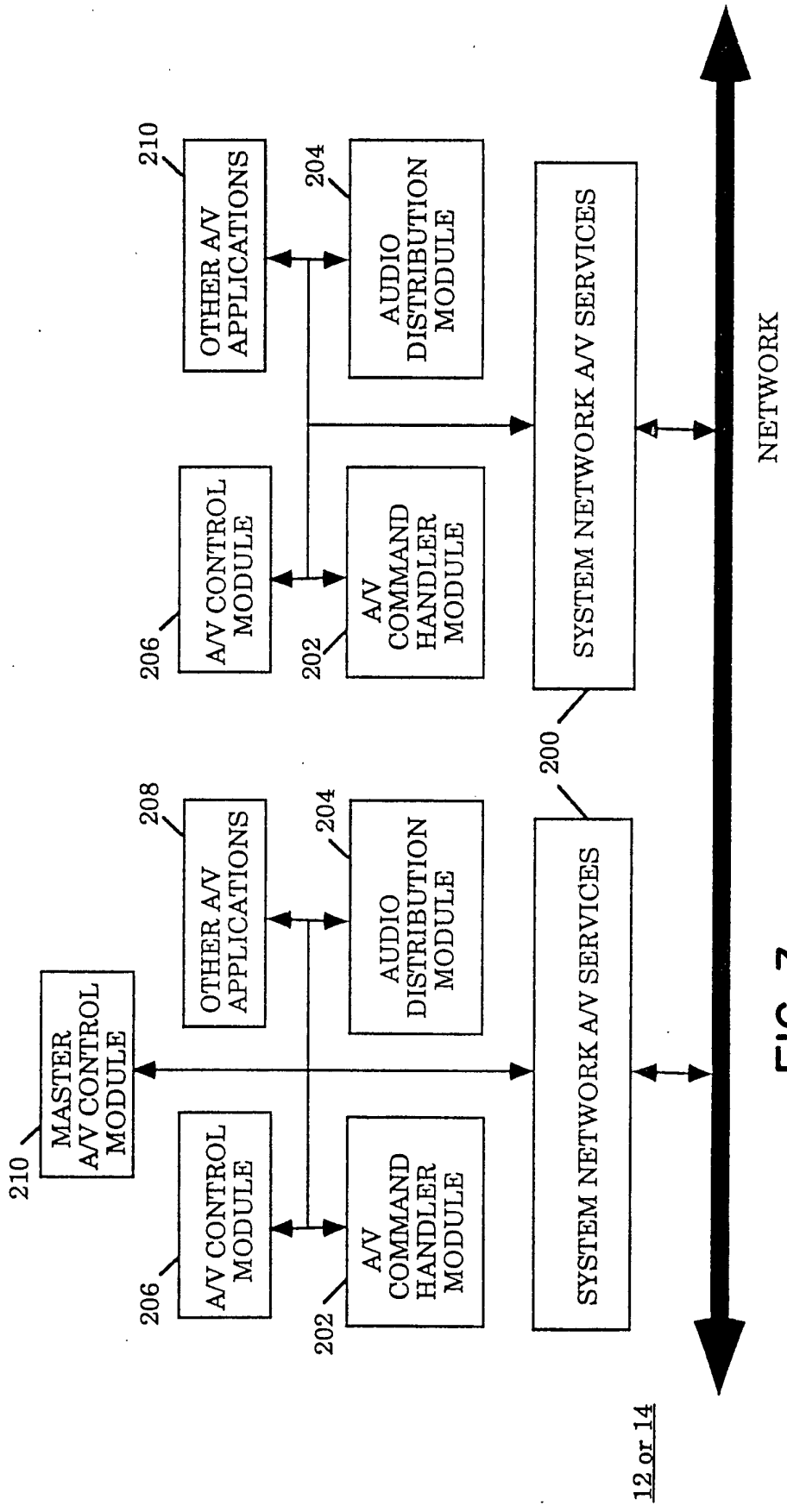

FIG. 3

12 or 14

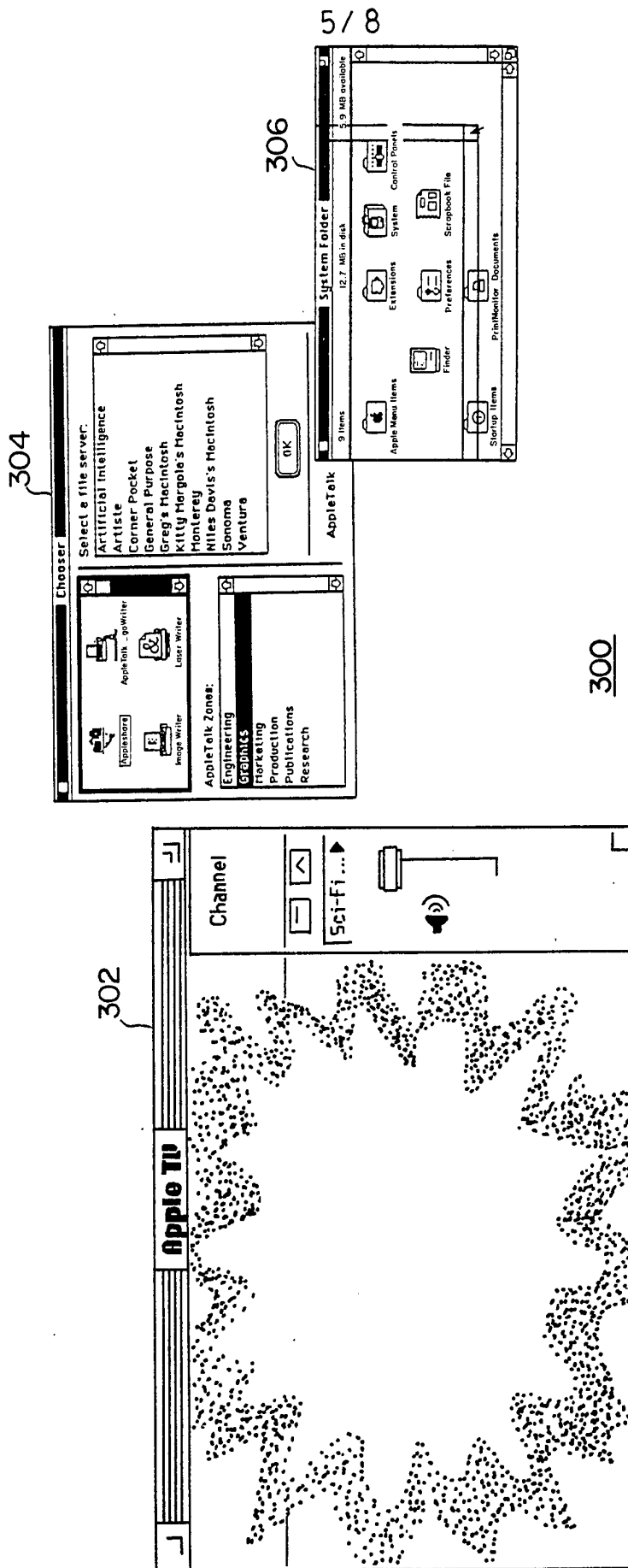

FIG. 4

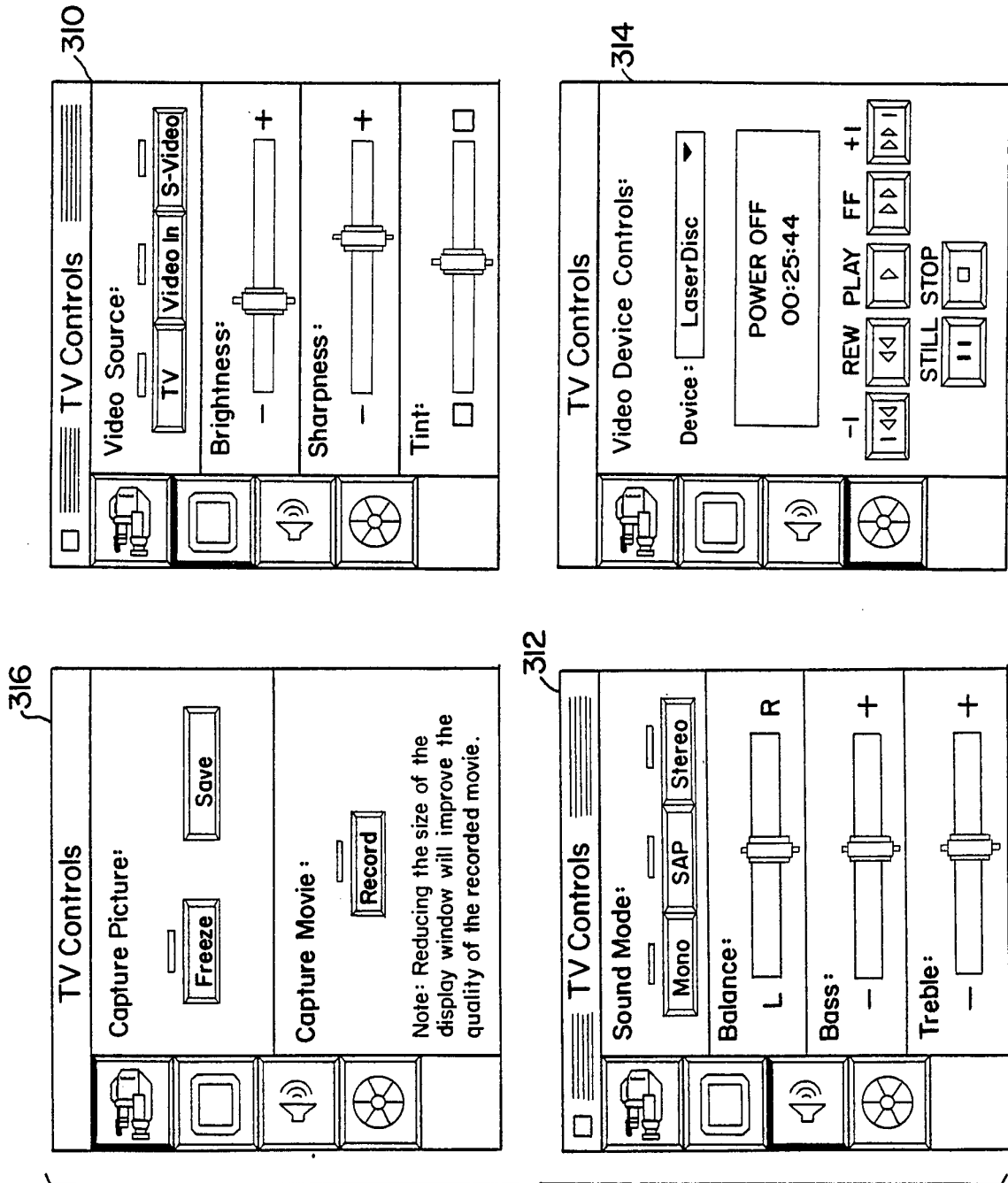

FIG. 5

320

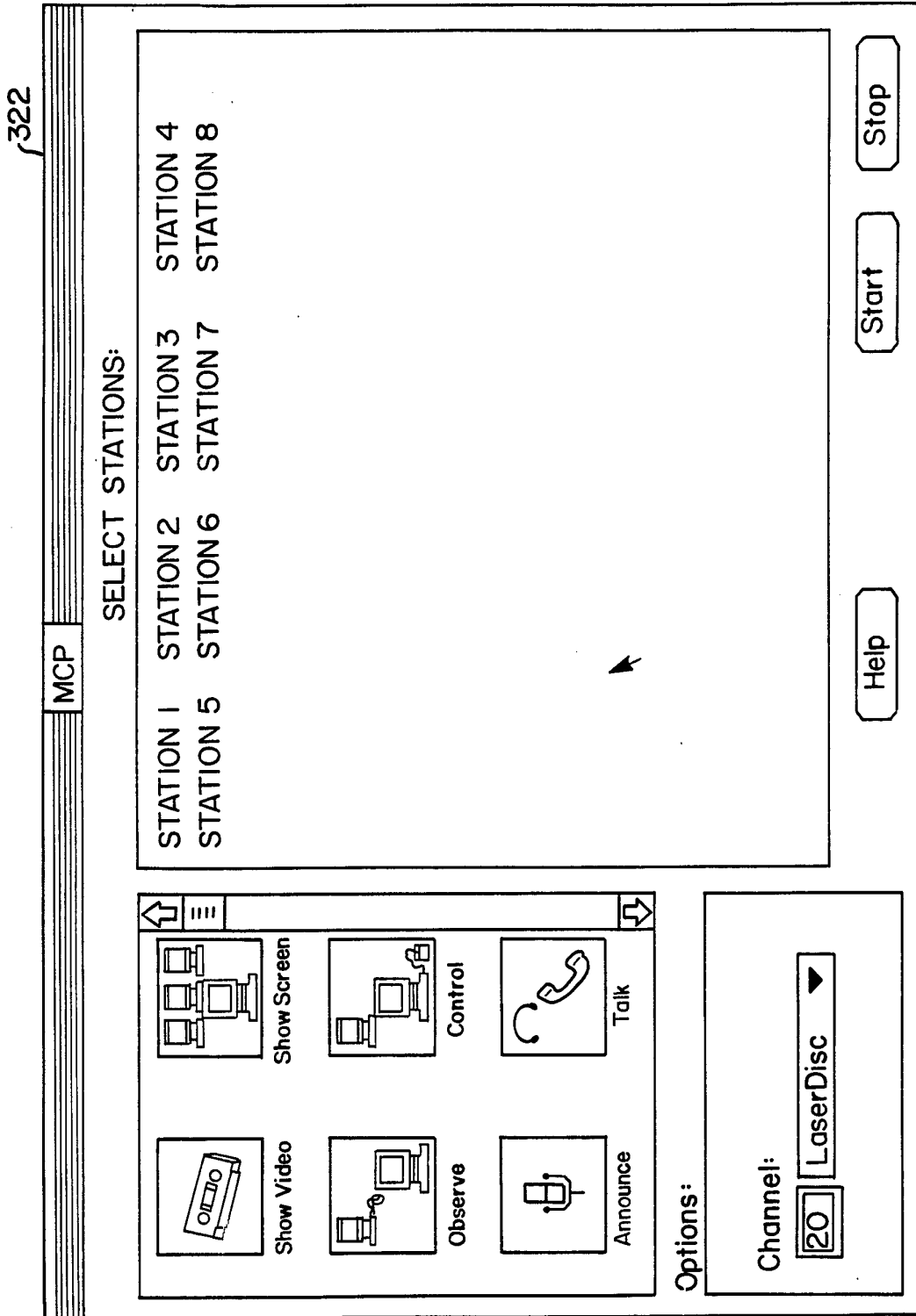

FIG. 6

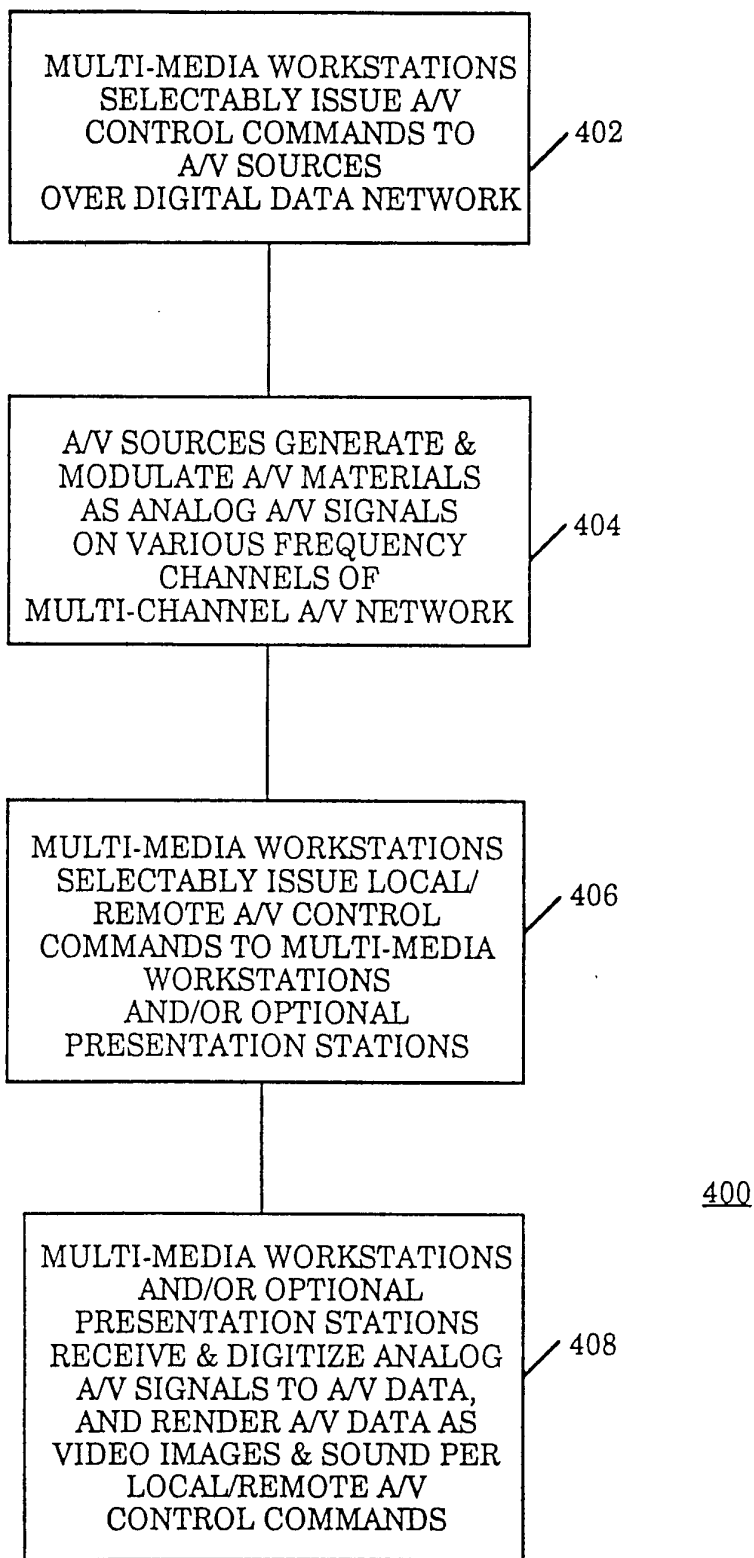

FIG. 7

INTERNATIONAL SEARCH REPORT

International Application No

PCT/US 95/02017

A. CLASSIFICATION OF SUBJECT MATTER
 IPC 6 H04N7/10 H04N7/173 G09B5/14

According to International Patent Classification (IPC) or to both national classification and IPC

B. FIELDS SEARCHED

Minimum documentation searched (classification system followed by classification symbols)
 IPC 6 H04N G09B

Documentation searched other than minimum documentation to the extent that such documents are included in the fields searched

Electronic data base consulted during the international search (name of data base and, where practical, search terms used)

C. DOCUMENTS CONSIDERED TO BE RELEVANT

Category*	Citation of document, with indication, where appropriate, of the relevant passages	Relevant to claim No.
P,X	US-A-5 318 450 (CARVER) 7 June 1994 see the whole document ---	1-16
X	IBM TECHNICAL DISCLOSURE BULLETIN, vol. 34, no. 7a, December 1991 NEW YORK US, pages 385-386, 'Automatic multiple source selection in a video conference' see the whole document ---	1-16
A	IBM TECHNICAL DISCLOSURE BULLETIN, vol. 34, no. 7a, December 1991 NEW YORK US, pages 375-377, 'Interactive computer conference server' see the whole document ---	1-16
	-/--	

Further documents are listed in the continuation of box C.

Patent family members are listed in annex.

* Special categories of cited documents :

- "A" document defining the general state of the art which is not considered to be of particular relevance
- "E" earlier document but published on or after the international filing date
- "L" document which may throw doubts on priority claim(s) or which is cited to establish the publication date of another citation or other special reason (as specified)
- "O" document referring to an oral disclosure, use, exhibition or other means
- "P" document published prior to the international filing date but later than the priority date claimed

- "T" later document published after the international filing date or priority date and not in conflict with the application but cited to understand the principle or theory underlying the invention
- "X" document of particular relevance; the claimed invention cannot be considered novel or cannot be considered to involve an inventive step when the document is taken alone
- "Y" document of particular relevance; the claimed invention cannot be considered to involve an inventive step when the document is combined with one or more other such documents, such combination being obvious to a person skilled in the art.
- "&" document member of the same patent family

Date of the actual completion of the international search

13 June 1995

Date of mailing of the international search report

28.06.95

Name and mailing address of the ISA

European Patent Office, P.B. 5818 Patentlaan 2
 NL - 2280 HV Rijswijk
 Tel. (+31-70) 340-2040, Tx. 31 651 epo nl,
 Fax: (+31-70) 340-3016

Authorized officer

Giannotti, P

INTERNATIONAL SEARCH REPORT

Intern. Application No

PCT/US 95/02017

C.(Continuation) DOCUMENTS CONSIDERED TO BE RELEVANT		
Category	Citation of document, with indication, where appropriate, of the relevant passages	Relevant to claim No.
A	SIGUCCS NEWSLETTER, vol. 22, no. 1, 1992 USA, pages 15--18, W.GILBERT 'Technical aspects of the AT&T Teaching Theater at the University of Maryland at College Park' see the whole document ---	1-16
A	US-A-4 920 432 (EGGERS ET AL.) 24 April 1990 cited in the application see column 3, line 13 - column 6, line 7 see abstract; figure 1 ---	1-16
A	US-A-5 276 866 (PAOLINI) 4 January 1994 see abstract; figure 2A see column 4, line 51 - column 5, line 57 ---	1-16
A	US-A-4 891 633 (IMAZEKI ET AL.) 2 January 1990 see abstract; figures 1,2,4 ---	1-16
A	EP-A-0 329 912 (INTERNATIONAL BUSINESS MACHINES CORPORATION) 30 August 1989 see abstract; figure 1 ---	1-16
A	EP-A-0 263 799 (CAPORALI) 13 April 1988 ---	
A	US-A-4 715 818 (SHAPIRO ET AL.) 29 December 1987 ---	
A	EP-A-0 279 558 (ING.C.OLIVETTI &C. S.P.A.) 24 August 1988 -----	

INTERNATIONAL SEARCH REPORT

Information on patent family members

International Application No

PCT/US 95/02017

Patent document cited in search report	Publication date	Patent family member(s)	Publication date
US-A-5318450	07-06-94	NONE	
US-A-4920432	24-04-90	NONE	
US-A-5276866	04-01-94	CA-A- 1331653	23-08-94
US-A-4891633	02-01-90	NONE	
EP-A-329912	30-08-89	US-A- 4885747 DE-D- 3852023 DE-T- 3852023 JP-A- 2007742	05-12-89 08-12-94 11-05-95 11-01-90
EP-A-263799	13-04-88	US-A- 4907146	06-03-90
US-A-4715818	29-12-87	NONE	
EP-A-279558	24-08-88	DE-A- 3882547	02-09-93