

J. EIBERWEISER.

Feed-Motors for Tobacco-Cutters.

No. 132,644.

Patented Oct. 29, 1872.

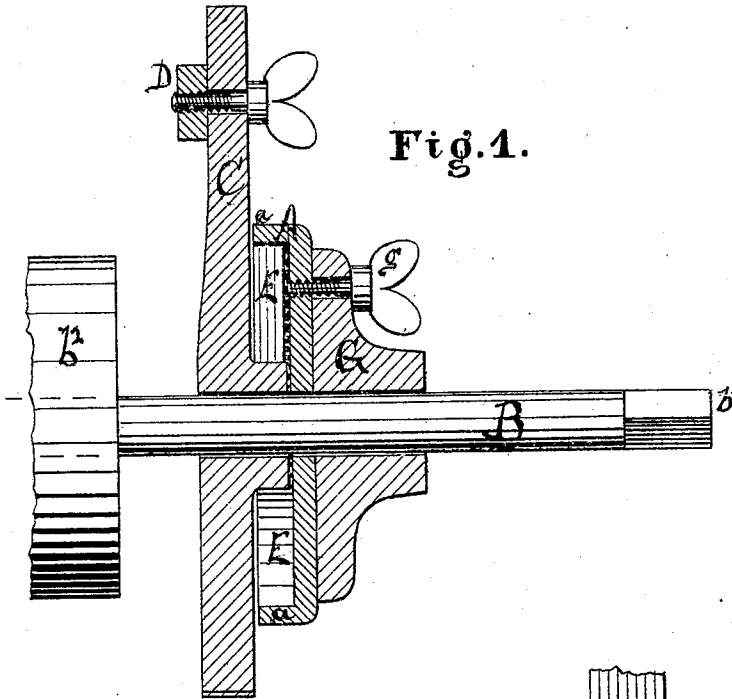

Fig. 1.

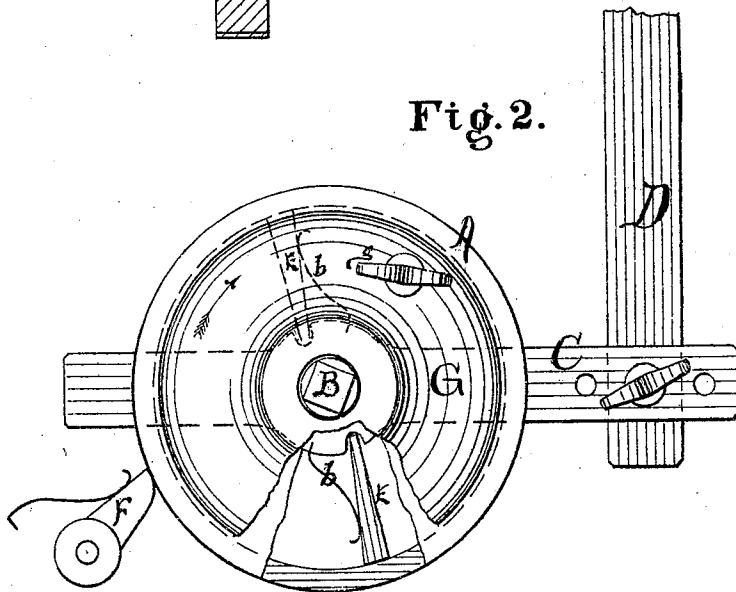

Fig. 2.

Attest.

Chas. H. Peaw
Geo. Barth

Inventor.

John Eiberweiser
By his atty
Wm. Smith

UNITED STATES PATENT OFFICE.

JOHN EIBERWEISER, OF CINCINNATI, OHIO.

IMPROVEMENT IN FEED-MOTORS FOR TOBACCO-CUTTERS.

Specification forming part of Letters Patent No. 132,644, dated October 29, 1872.

To all whom it may concern:

Be it known that I, JOHN EIBERWEISER, of Cincinnati, county of Hamilton, and State of Ohio, have invented a new and useful Improvement in Tobacco-Cutters; and I do hereby declare that the following is a full, clear, and exact description of the same, reference being had to the annexed drawing making a part of this specification.

Figure 1 is a vertical section, and Fig. 2 is a side elevation of the same.

Similar letters of reference indicate like parts.

The nature of my improvement relates to a new and useful device in tobacco-cutters, wherein the feeding apparatus is operated by means of a lever and friction-pawls acting concentrically against a rim formed on the feed-wheel. It is further provided with a stop-pawl resting against the outside periphery of said feed-wheel to prevent it from backing while the lever is making a backward movement. It is also provided with a device for disengaging the feeding device from the shaft carrying it in such manner that the shaft may be rotated by means of a crank without disturbing the feed-wheel.

In construction my invention is as follows: A is the feed-wheel rotating on the shaft B. At C is a lever, perforated at various points to admit a thumb-screw forming the joint with the connecting-rod D. Two pawls, E E, let into recesses on the hub of the lever C, and set slightly out of the radius, form a tight hold on the rim *a* of the feed-wheel. Springs *b* are set so as to keep the pawls E E continually in contact with the rim *a*. A check-pawl, F, is set outside the periphery of the feed-wheel, which keeps it from making a backward motion. The connecting-rod D receives its motion from a cam on the machine, (not represented in the drawing.) The face-plate G is permanently attached to the shaft B, while the feed-wheel A is not fixed thereto directly,

but is held tightly to face-plate G by means of the thumb-screw *g*. The end of shaft B is made square to receive a crank at *b*¹, while *b*² represents a section of the pulley carrying the feeding-belt.

In operation, my invention is as follows: When tobacco is first placed in the machine the thumb-screw *g* is withdrawn, and a crank placed on the shaft B, and the pulley *b*² rotated, which brings the tobacco to the cutters without the loss of time otherwise necessary. The face-plate and feed-wheel are then again fastened together by means of the screw *g*, and the cutting continued. The lever C, in being moved one direction, allows the pawls E to move freely over the feed-wheel, but on the lever being moved the opposite direction the pawls acting against the rim *a* of the feed-wheel move it forward, the purpose of pawl F being simply to prevent any backing motion of the wheel A. In adjusting this device it is only necessary to move the joint formed by the lever C and rod D, whereby the lever receives more or less stroke, and the degree of motion communicated to the wheel will be correspondingly varied. In cutting coarse the joint is brought nearer the feed-wheel, and if desired to cut fine the joint is formed further from the same.

Having thus described my invention, what I claim as new, and desire to secure by Letters Patent, is—

1. In a tobacco-cutter, the combination of the shaft B and vibrating lever C with the rim-wheel A, the inner friction-pawls E, and outer friction-pawl F, to form a feed-motion, substantially as specified.

2. In combination with the subject matter of the above claim, the hub G, coupled by the thumb-screw *g*, substantially as set forth.

JOHN EIBERWEISER.

Witnesses:

T. VAN KANNEL,
ABR. VON KAENNEL.