

W. J. DUNHAM.
 FEED REGULATOR FOR CONCRETE MIXING MACHINES.
 APPLICATION FILED MAY 20, 1914.

1,170,804.

Patented Feb. 8, 1916.
 2 SHEETS—SHEET 1.

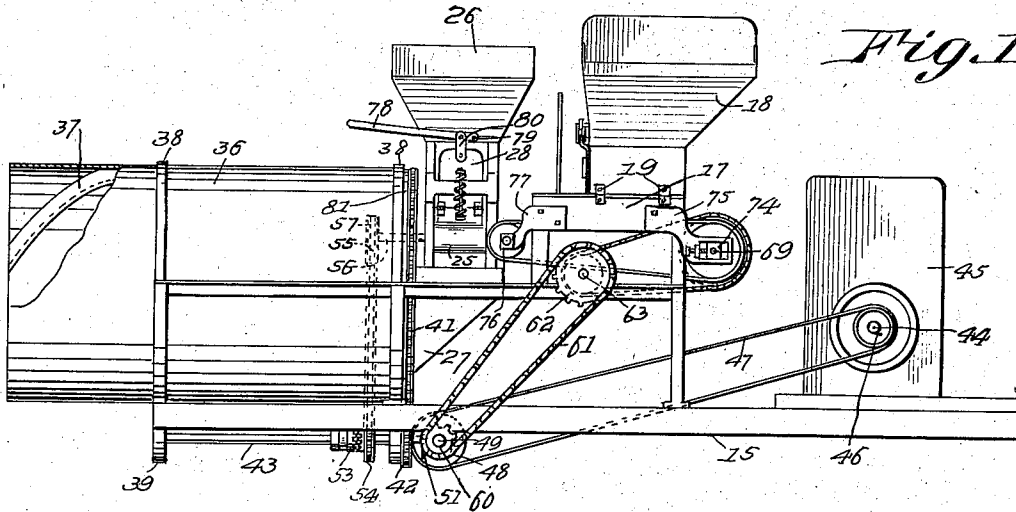

Fig. 1.

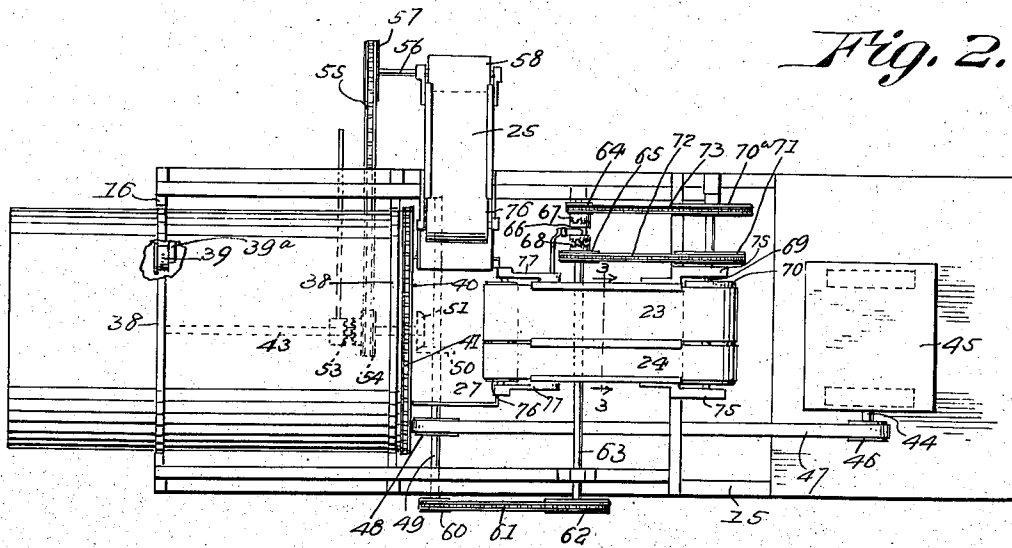

Fig. 2.

Witnesses
 P. W. Putnam,
 H. C. Clarkley,

Inventor,
 William J. Dunham,
 Frank S. Appleman
 Attorney

W. J. DUNHAM.
 FEED REGULATOR FOR CONCRETE MIXING MACHINES.
 APPLICATION FILED MAY 20, 1914.

1,170,804.

Patented Feb. 8, 1916.

2 SHEETS—SHEET 2.

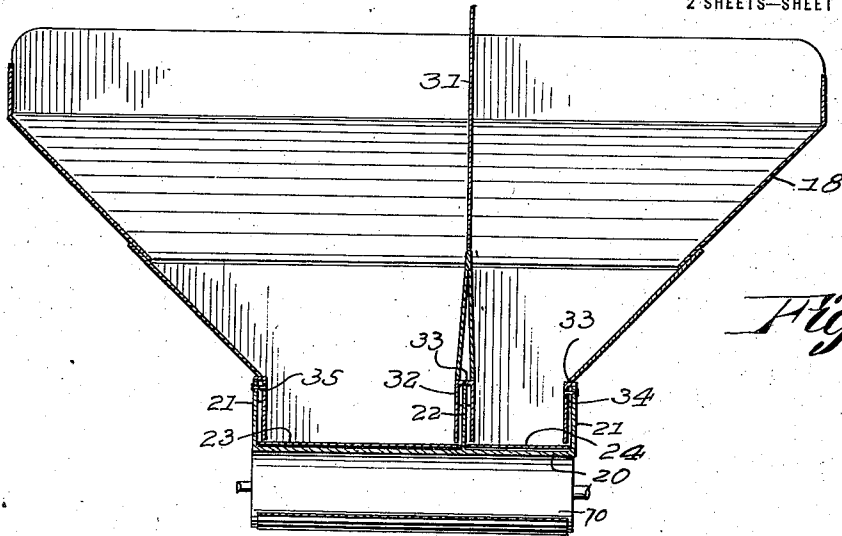

Fig. 3.

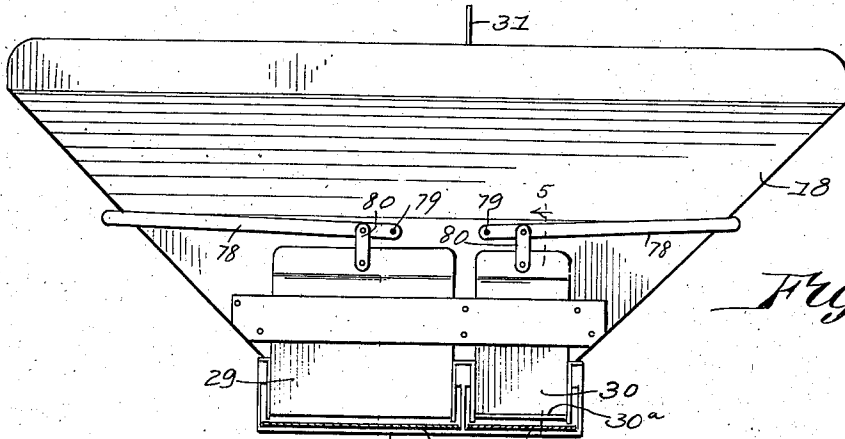

Fig. 4.

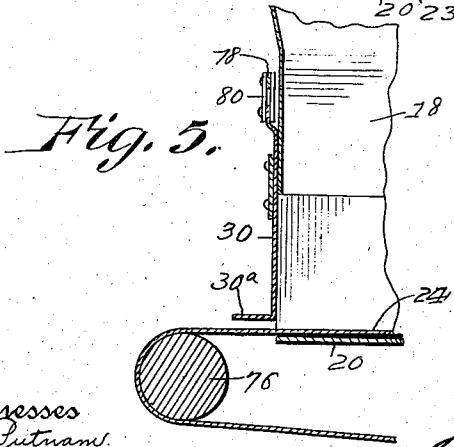

Fig. 5.

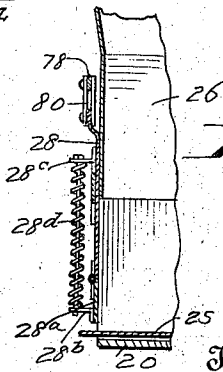

Fig. 6.

Witnesses
 P. A. Putnam,
 S. C. Barkley.

Inventor
 William J. Dunham,
 Frank S. Appleman
 Attorney

UNITED STATES PATENT OFFICE.

WILLIAM J. DUNHAM, OF JOHNSTOWN, NEW YORK.

FEED-REGULATOR FOR CONCRETE-MIXING MACHINES.

1,170,804.

Specification of Letters Patent.

Patented Feb. 8, 1916.

Application filed May 20, 1914. Serial No. 839,865.

To all whom it may concern:

Be it known that I, WILLIAM J. DUNHAM, a citizen of the United States of America, and resident of Johnstown, in the county of Fulton and State of New York, have invented certain new and useful Improvements in Feed-Regulators for Concrete-Mixing Machines, of which the following is a specification.

10 This invention relates to machines for mixing concrete and the like and has for its object the provision of novel means for delivering predetermined amounts of the ingredients of the composition to a mixer where the same may be agitated and com-
15 mingled, preparatory to moistening the same, means being also provided for delivering liquid to the interior of the mixer or agitator so that the composition in emerg-
20 ing from the mixer will be in condition for use.

A further object of this invention is to provide means for effecting a positive feeding operation for the cement as well as the
25 coarser particles of material employed in compositions of matter to be used for the production of so called artificial stone, plastic bricks and for other uses as in the laying of side walks, roadbeds, etc.

30 A further object of this invention is to provide a mixing machine of the character indicated having novel means for confining the materials to the conveyers whereby the material is prevented from gaining access to
35 the working parts of the mechanism and preventing loss, due to the escape of such material.

A still further object of this invention is to provide novel means for operating the
40 conveying means and for simultaneously driving or rotating the mixing chamber so that the material may be delivered to the mixer by members which move continuously in a clockwise or counter clockwise direction,
45 according to the manner of mounting the carrying members and driving them.

A still further object of this invention is to provide novel means for controlling the
50 egress of the material from the containers or hoppers and particularly in the provision

of novel means for controlling the outlet opening for the cement, provision being made for guarding against the so-called boiling of the cement, which is due to its characteristic flowing or running qualities. 55

In describing the invention in detail, reference will be had to the accompanying drawings forming part of this specification, wherein like characters denote correspond-
60 ing parts in the several views and in which—

Figure 1 illustrates a view in elevation of the machine with the truck or support thereof omitted; Fig. 2 illustrates a top plan view, omitting the hoppers; Fig. 3 illustrates a vertical sectional view of the hop-
65 per and conveyer; Fig. 4 illustrates an end view showing the hopper in elevation; Fig. 5 illustrates a sectional view on the line 5—5 of Fig. 4; and Fig. 6 illustrates a detail view of one of the doors for coarse ma-
70 terial.

In these drawings, I have shown a frame
15 which is adapted to be supported in trucks of any appropriate type or on skids, or the frame may be otherwise supported
75 but as the particular feature of supporting or transporting it is immaterial, means are not here shown for that purpose. The said frame supports slings or yokes 16 and
80 brackets 17, the latter of which constitute supports for the hopper 18, which hopper is connected to the brackets 17 by the angle
85 irons 19. A conveyer bed 20 is supported to be located beneath the discharge and to extend in front of the hopper and is divided
85 into longitudinally disposed channels by the side flanges 21 and intermediately disposed
90 rib 22. Between the rib 22 and one of the side flanges, there is a conveyer belt 23 and between the said rib and the opposite side
90 flange is a conveyer belt 24. The distance between the rib and one of the side flanges is greater than the space between the said
95 rib and the opposite side flange as it has been ascertained in practice that the conveyer belt 24 which is designed for the pur-
95 pose of carrying cement may be of less capacity than the conveyer 24 utilized for conveying sand, gravel or other coarser particles
100 which are to be used in the composition of

matter; in fact, the formula in most instances requires two-thirds or approximately two-thirds of the coarser material and about one-third of the cement, therefore, the capacity of the conveyers need not be the same. Provision is furthermore made in this invention for delivering to the mixer a still coarser material such as crushed stone, the last mentioned result being attained through the medium of a transversely disposed conveyer 25, leading from the hopper 26, and discharging into the chute 27 and the chute 27 is also in position to receive materials from the conveyer belts 23 and 24. The hoppers have discharge openings which allow the material to be deposited on the conveyers and the said openings are guarded by sliding shutters or doors 28, 29 and 30, the latter of which is used for controlling the exit opening of the cement. In describing the hopper 18, it might be well to say that it has a partition 31 therein so that it is divided into two compartments to retain the gravel and cement in a separated state until it is delivered to the chute through the medium of the conveyers. The door which guards the discharge opening for the cement has an outwardly extending flange 30^a which forms a bevel plate or buffer to prevent upward travel of the cement as it emerges from the hopper.

As a means for guarding against the discharge of material laterally to prevent its finding access to the under surface of the conveyer, guards 32 are provided and they are attached to the side flanges and the intermediate rib so that their edges overlies the upper surface of the conveyer belts. In the construction of these guards, longitudinally disposed plates are utilized, the said plates having flanges 33 at their upper edges, which are designed to overlies the upper edges of the side flanges or the upper edge of the intermediate rib according to whether the said guards are applied to the side flanges or the rib. In other words, the guards are interchangeable and may be used on the side flanges or the rib. At certain points throughout the length of the guard, bosses or thickened portions 34 are formed, the same being apertured for the reception of the securing bolts 35 which bolts pass through the said apertures and through apertures formed in the side flanges or intermediate rib so that the guard is bound or secured to one of said members. As will be seen by reference to the sectional view, the intermediate rib has a guard on each side and the flanges of these guards abut on the upper surface of the rib and as they are bound together by the bolts they are retained in place and access of material to the edges of the conveyers is prevented.

The mixer 36 consists in part of a cylin-

drical rumble having spirally arranged blades 37 of appropriate pitch and inclination to carry the material delivered to the mixer toward the rear end thereof where it is discharged to any appropriate receptacle or support.

As a means for rotating the mixer, 36, the same is provided with annular ribs 38 forming tracks which run on rollers 39 appropriately journaled and supported by the stirrups or slings 39^a which are anchored on the sills or frame.

The mixer cylindrical member 36 has one end partially closed by an apertured disk 40 having a toothed periphery which teeth are engaged by the sprocket chain 41 driven from the sprocket wheel 42 on a shaft 43 which shaft is journaled in the yokes or stirrups 39.

The power shaft 44 is driven by any appropriate motor which may be placed within the casing 45, the particular type of motor being immaterial. The drive shaft 44 is provided with a pulley 46 having a belt 47 which runs over a pulley 48 on the driven shaft 49. The driven shaft 49 has a beveled gear wheel 50 which drives a beveled gear wheel 51 on the shaft 43 and the said shaft 43 has a clutch 53 for connecting and disconnecting the sprocket wheel 54 with the said shaft 43 so that the sprocket chain 55 may be driven to rotate the shaft 56 through the medium of the sprocket wheel 57. The shaft 56 has a drum or pulley 58 over which the conveyer belt 59 is run, the said conveyer and belt being in position to discharge material to the chute leading to the mixer. The bed for the conveyer belt 59 is the same as the bed for the conveyers for the cement and gravel and the guard and other parts thereof are the same as described in connection with the description of the first mentioned conveyers and therefore, a further detailed description is believed unnecessary.

The driven shaft 49 has a sprocket wheel 60 with a sprocket chain 61 running over a sprocket wheel 62 which latter sprocket wheel is on a transversely disposed shaft 63 carrying two sprocket wheels 64 and 65, one of which is larger than the other. The shaft 63 is furthermore provided with a double clutch 66 which operate with clutch members 67 and 68 on the sprocket wheels 64 and 65 respectively, so that the clutch members may be operated to cause either the wheel 64 or 65 to rotate under the influence of the shaft 63. A shaft 69 is journaled in appropriate brackets and it carries a drum or pulley 70 over which the conveyer belts 23 and 24 travel and by which they are moved. In order to rotate the shaft 69, sprocket wheels 70^a and 71 are secured to it and they are engaged by chains 72 and 73 which are driven by the sprocket

wheels 64 and 65 respectively so that by reason of the use of the clutch, the conveyer may be driven at an increased or diminished speed depending upon the wheel which is
5 utilized for communicating power to the shaft 69.

The bearings 74 for the shaft 69 are adjustably mounted in the brackets 75 which brackets are supported as shown and by
10 reason of the adjustability of the bearings, the conveyer belts may be tightened or adjusted to take up lost motion. The conveyers 23 and 24 are caused to run over an idler 76 which is rotatably mounted in the
15 brackets 77.

The doors 28, 29 and 30 are similarly operated by means of levers or handles 78 mounted on studs 79 and connected by links
20 80 with the appropriate doors so that motion of a handle or lever may be communicated to a door. The doors that are used for guarding the passage of coarse material such as gravel or crushed stone are preferably joined near the lower end by a hinge such
25 as shown in the drawing. A detailed construction of one of the doors 28 will serve as an illustration of the construction of the door 29. The lower part of the door 28 has a hinged section 28^a provided with a stud
30 28^b. The upper section of the door has a stud 28^c with a spring 28^d between them which serves to hold the sections in alignment under normal conditions of operation
35 but the spring is provided so that the lower section may yield to prevent clogging of the passage-way for the material should an unusually large piece of material travel in the chute and contact the lower portion of the
40 door, as the said lower portion may be swung outwardly to allow the larger piece to pass thereunder.

It has been found in practice by the use of the apparatus just described that the hopper doors may be set at predetermined positions
45 to insure such regularity of feed of material from the hoppers as to enable the operator to determine the number of cubic feet of material which will be mixed ready for use. For instance, if a formula calls for one third
50 of cement and two thirds of the coarser material, it is known that such material will produce a given number of cubic feet of the product whether it be artificial stone or material for a roadbed and by reason of the
55 fact that the feeding operation for the different materials is a continuous and not an intermittent feed, insures such a positive and accurate result as to enable the operator to take from the machine a predetermined
60 amount of material or supplies furnished for use in the machine.

It is well known that there are intermittent feeding devices designed to accomplish the result attained by this invention but the

intermittent devices such as plungers disturb the material in the hoppers on the return movement and interfere with a proper flow or travel of the said material to the exit openings of the hoppers, and this to a great extent accounts for the inaccuracies
70 which have been discovered in the operation of machines of that type.

I claim:

1. In a feed regulator for concrete mixing machines, the combination of a hopper,
75 a conveyer bed having side flanges and an intermediate partition, conveyer belts running between the side flanges and the intermediate partition, means for driving the conveyer belt, and guards secured to the
80 side flanges and the intermediate partition for preventing material gaining access to the edges of the conveyer belts.

2. In a feed regulator for concrete mixing machines, the combination of a hopper,
85 a conveyer bed having side flanges and an intermediate partition, a conveyer belt between one of the side flanges and the intermediate partition, a conveyer belt between the opposite side flange and the intermediate
90 partition, means for driving the said belts, guards secured to the side flanges and intermediate partition, said guards having their edges terminating above the conveyer belts to prevent material gaining access
95 thereto.

3. In a feed regulator for concrete mixing machines, the combination of a hopper, a conveyer bed, and to one side of the longitudinal center of the hopper, side flanges and
100 an intermediate partition extending longitudinally of the said bed, conveyer belts on the bed, means for driving the said conveyer belts, guards adapted to lie parallel with the side flanges and intermediate partition, said
105 guard having flanges at the upper edges overlying the side flanges and intermediate partition, apertured bosses on the said guards, and means for securing the guards to the said flanges and intermediate
110 partition.

4. In a feed regulator for concrete mixing machines, the combination of a hopper for pulverulent material having discharge openings at one end, a partition for separating
115 the hopper into two compartments having discharge openings of unequal area, a bed for the conveyer belts which is common to both compartments of the hopper, means for associating a conveyer bed with the hopper,
120 and means within the hopper maintained to overlie the longitudinal edges of the conveyer belts.

5. In a feed regulator for concrete mixing machines, a hopper having a partition, the
125 lower end of which is separated longitudinally, a rib maintained to extend between the separated end of the partition, traveling

conveyer belts, the side edges of which are overlaid by the ends of the partition, depending means for overlying the other edges of the belt, and a rigid bed associated with
5 the hopper and upon which the conveyer travels.

In testimony whereof, I hereunto affix my signature in the presence of two witnesses.
WILLIAM J. DUNHAM.

Witnesses:

PEARL A. PUTNAM,
LOTTIE E. BARKLEY.