

N. CRONKITE.

Wheelbarrow.

No. 103,430.

Patented May 24, 1870.

Fig. 1

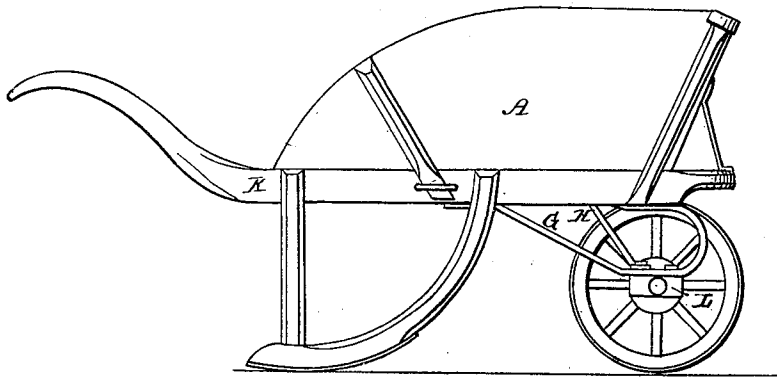
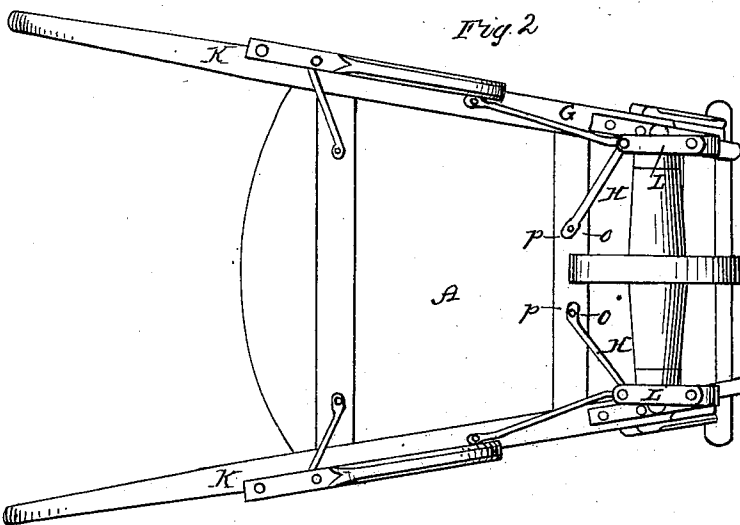

Fig. 2



Witnesses
James L. Norris
M. A. Fincher

Inventor
Nelson Cronkite
by Gundersen & Norris
Attorneys

UNITED STATES PATENT OFFICE

NELSON CRONKITE, OF MILFORD, NEW YORK.

IMPROVEMENT IN WHEELBARROW.

Specification forming part of Letters Patent No. **103,430**, dated May 24, 1870.

To all whom it may concern:

Be it known that I, NELSON CRONKITE, of Milford, in the county of Otsego and State of New York, have invented a new and useful Improvement in Hand or Wheel Barrows; and I do hereby declare that the following is a full, clear, and exact description of the construction and operation of the same, reference being had to the accompanying drawing, making part of this specification, in which—

Figure 1 is a side elevation of my improved hand or wheel barrow. Fig. 2 is a bottom view of the same.

This invention relates to that class of devices known as "hand" or "wheel" barrows; and it consists in the peculiar construction and arrangement of the hanger or stirrups upon which the journals of the wheel are mounted, so as to transfer the weight of a load from the hands of the operator mostly to the bearings of the wheel, all of which will hereinafter be described.

A A in the drawings represent the hand or wheel barrow. The framing constituting the same is not necessary to be described, it being that of the ordinary construction.

K K are the handles, which extend forward from the side sills of the barrow, at or near the ends of which are firmly secured the hangers or stirrups, provided with bearings for the journal of the wheel or wheels, hereinafter mentioned.

G G are the metal hangers or stirrups, made either of cast or wrought iron, or of spring-steel, as may be desired. One end of these hangers or stirrups are rigidly attached, at or near the front ends, by means of clips or bolts, to the handles or side sills, and extending forward are curved or bent backwardly, and secured at a point on said handles or sills in the rear of the wheel or wheels.

L L are the bearings of the journals of the wheel or wheels, made either of metal or wood, secured in a substantial manner, either within or on the lower side of the hanger or stirrups, by bolts, clips, or other suitable fastening devices. These bearings L L can be formed with the hanger or stirrups, if de-

sired, thus dispensing with the use of bolts or clips; but I much prefer the same to be detachable, as new ones can be readily applied when the old ones become worn or injured from long use.

H H are the supporting-braces, formed with feet *o o*, one end of which are secured to the bottom or cross piece of the hand or wheel barrow, as at *p p*, the other being rigidly joined to the hanger or stirrups and journal-bearings by means of bolts or clips; or, if bolts be used, one is made of a length sufficient to pass entirely through openings and secure together the hanger or stirrup, the journal-bearing, and the supporting-brace. These supporting-braces prevent all lateral movement of the hangers or stirrups, and also aid, to a considerable extent, to prevent the displacement of the journal-bearings.

It will thus be readily seen that by the peculiar construction and arrangement of the hangers or stirrups with their journal-bearings, and arranging the wheel or wheels within the same, at or near the point indicated in the drawing, the handles being slightly raised, the weight of a load is, to a great extent, transferred from the hand of the operator to the front of the hand or wheel barrow, the position of the barrow being such that a line falling from the upper edge of the end-board will be on a line with the front breast of the wheel or wheels.

Having thus described my invention, what I claim as new, and desire to secure by Letters Patent, is—

1. The curved suspended hangers or stirrups, having their ends secured to the side sills of the barrow, and carrying the journal-boxes of the wheel, substantially as and for the purpose described.

2. In combination therewith, the supporting-braces, extended inwardly and connected to one of the cross-bars beneath the barrow, substantially as shown and described.

NELSON CRONKITE.

Witnesses:

GEORGE WESTCOTT,
CHARLES PACKER.