

(19) World Intellectual Property Organization
International Bureau



(43) International Publication Date
29 May 2008 (29.05.2008)

PCT

(10) International Publication Number
WO 2008/062149 A1

(51) International Patent Classification:
G02F 1/15 (2006.01) *H01B 1/12* (2006.01)

(21) International Application Number:
PCT/GB2007/002897

(22) International Filing Date: 30 July 2007 (30.07.2007)

(25) Filing Language: English

(26) Publication Language: English

(30) Priority Data:
0623108.8 20 November 2006 (20.11.2006) GB

(71) Applicants (for all designated States except US): **SERICOL LIMITED** [GB/GB]; Patricia Way, Pysons Road Industrial Estate, Broadstairs, Kent CT10 2LE (GB). **ACREO AB** [SE/SE]; Bredgatan 34, SE-602 21 Norrköping (SE).

(72) Inventors; and

(75) Inventors/Applicants (for US only): **GOULD, Nigel** [GB/GB]; Fujilm Sericol Limited, Patricia Way, Pysons Road Industrial Estate, Broadstairs, Kent CT10 2LE (GB). **ABBASI, Fereidoun** [GB/GB]; Fujilm Sericol Limited, Patricia Way, Pysons Road Industrial Estate, Broadstairs, Kent CT10 2LE (GB). **BATTING, Adam, Joseph, Howard** [GB/GB]; Fujilm Sericol Limited, Patricia Way, Pysons Road Industrial Estate, Broadstairs, Kent CT10 2LE (GB). **SANDBERG, Mats** [SE/SE]; ACREO AB,

Bredgatan 34, SE-602 21 Norrköping (SE). **SAWATDEE, Anurak** [SE/SE]; ACREO AB, Bredgatan 34, SE-602 21 Norrköping (SE). **HENNERDAL, Lars-Olov** [SE/SE]; ACREO AB, Bredgatan 34, SE-602 21 Norrköping (SE).

(74) Agent: **ELKINGTON AND FIFE LLP**; Prospect House, 8 Pembroke Road, Sevenoaks, Kent TN13 1XR (GB).

(81) Designated States (unless otherwise indicated, for every kind of national protection available): AE, AG, AL, AM, AT, AU, AZ, BA, BB, BG, BH, BR, BW, BY, BZ, CA, CH, CN, CO, CR, CU, CZ, DE, DK, DM, DO, DZ, EC, EE, EG, ES, FI, GB, GD, GE, GH, GM, GT, HN, HR, HU, ID, IL, IN, IS, JP, KE, KG, KM, KN, KP, KR, KZ, LA, LC, LK, LR, LS, LT, LU, LY, MA, MD, ME, MG, MK, MN, MW, MX, MY, MZ, NA, NG, NI, NO, NZ, OM, PG, PH, PL, PT, RO, RS, RU, SC, SD, SE, SG, SK, SL, SM, SV, SY, TJ, TM, TN, TR, TT, TZ, UA, UG, US, UZ, VC, VN, ZA, ZM, ZW.

(84) Designated States (unless otherwise indicated, for every kind of regional protection available): ARIPO (BW, GH, GM, KE, LS, MW, MZ, NA, SD, SL, SZ, TZ, UG, ZM, ZW), Eurasian (AM, AZ, BY, KG, KZ, MD, RU, TJ, TM), European (AT, BE, BG, CH, CY, CZ, DE, DK, EE, ES, FI, FR, GB, GR, HU, IE, IS, IT, LT, LU, LV, MC, MT, NL, PL, PT, RO, SE, SI, SK, TR), OAPI (BF, BJ, CF, CG, CI, CM, GA, GN, GQ, GW, ML, MR, NE, SN, TD, TG).

Published:
— with international search report

(54) Title: IONIC LIQUID

(57) Abstract: This invention relates to a printable composition and in particular to a printable composition for application to an electrochromic and/or electrochemical device. The printable electrolyte composition for the production of electrochemical devices comprises: 20-50% by weight, based on the total amount of the composition, of a thermally-curable base which comprises a resin; 20-70% by weight, based on the total amount of the composition, of a solvent; and 10-50% by weight, based on the total amount of the composition, of an electrolyte, wherein the composition has a viscosity of 0.3 Pas or higher.



WO 2008/062149 A1

Ionic liquid

This invention relates to a printable composition and in particular to a printable composition for application to an electrochromic and/or electrochemical device.

5 Traditionally electronic devices were constructed with inorganic conductors, such as copper, and semi-conductors, such as silicon. However, conductive organic polymers provide advantages in that they are that they are lighter, more flexible and less expensive than inorganic conductors. With organic electronics it is possible to create many of the electronic products already
10 available on the market today as well as some which are entirely new. The present invention is directed to devices incorporating an electrochromic display or other electrochemical components such as a battery, a transistor, a diode or sensor or combination of these components. The device may e.g. be connected to a electric circuitry or chip made of silicon. More particularly,
15 present invention is directed to electrochromic displays and/or electrochemical devices produced by conventional printing techniques.

Conductive polymers are well-known materials typically incorporating a linear chain of conjugated units which becomes highly conductive on doping. Many
20 conjugated polymers can undergo reversible electrochemical oxidation and reduction through the application of a positive or negative bias in the presence of an electrolyte or electrolyte composition. When switching a conjugated polymer between its oxidation and reduction states the fundamental electronic and optical structure of the polymer changes. The
25 electronic structure change makes the conductivity change from e.g. nearly insulating to a conductive material, or vice versa. For electrochromic polymer materials the change in conductivity also provides a change in the optical properties of the polymer, i.e. provides a change in its colour (termed electrochromism). This ability makes conjugated polymers a good choice for
30 creating displays. The optical and electronic change of the polymer depends on the material and its doping level.

A wide range of suitable conducting polymers is available, which may or may not be electrochromic. An example is the conducting polymer poly(3,4-ethylenedioxythiophen) doped with poly(styrene sulfonic acid) (PEDOT:PSS).

5 In the reduced state a PEDOT:PSS film has a low conductivity and a deep-blue colour; in the oxidised state the conductivity is high and the colour nearly transparent.

US 10/819 306 gives basic examples, which describe how electrochemical
10 components such as transistors, displays and logical circuits may be arranged and manufactured using electrochemically active elements of e.g. conductive polymers, and a solidified electrolyte composition. Basically, two elements of electrically conductive and electrochemically active material is arranged adjacent to each other. An electronically insulating gap between the
15 two elements is bridged by an electrolyte. Further, the electrolyte provides ionic contact between the two elements. As a voltage is applied across the electrolyte the conductivity of the electrochemically active material is changed at the interface between the electrolyte and the conductive material. Thus, a current in the electrochemically active material can be controlled by means of
20 a voltage applied to the electrolyte. US 10/496 653 gives further examples of how to arrange and manufacture other components based on the same principle.

In one example of a technique for the manufacture of an electrochromic
25 device, a conducting polymer film is applied to a suitable substrate. A pattern is then formed in the film by irreversibly over oxidising or reducing the conducting polymer in certain defined areas. The thus-treated polymer film is then over-printed with an electrolyte layer and the electrolyte layer is subsequently encapsulated. See US 2005/0068603 for further details.

30

In the following, one example of how to manufacture an electrochemical component is described. Other well known techniques for forming an electrochemical device, e.g. without the use of electrolyte, applying the electrolyte

and possibly encapsulating the device may be found in US 10/819 306, US 10 496 653 WO 03/25953 and WO 05/27599. The first step in the printing process is a subtractive patterning technique. Here, a pattern with non-conducting lines is created in the conducting PEDOT:PSS film. These lines
5 define the conducting areas of the display. The typical thickness of the lines is 100-200 μm . Fig. 1 shows the electrochemically produced pattern for a one-pixel electrochromic display. The black lines are the electrochemically produced pattern. The patterning is performed with an electrolyte ink (often termed "killyte"). The killyte is grounded and the PEDOT:PSS film is
10 connected to a power supply (e.g. 150 V). The killyte is then applied to the PEDOT:PSS film using a suitable printing technique, such as screen printing. As the killyte comes in contact with the PEDOT:PSS film, the circuit is closed. The high potential creates a large current which overoxidises the PEDOT:PSS in an irreversible process. The overoxidation permanently
15 deactivates the conductivity of the PEDOT:PSS areas contacted by the killyte.

The killyte which comes in contact with the substrate during the electrochemical patterning step remains in place in the eventual device. It must therefore be dried or cured into a dry plastic-like film before the next
20 processing step. Curing the killyte also ensures that it will not stick or dry on other pieces of equipment, making the cleaning and maintenance of the press easier. The simplest technique is simply to evaporate the solvent from the active solution, but other techniques, such as thermal or UV curing, may be used instead.

25

As an alternative to the use of killyte, a conducting polymer film may be printed directly on to the substrate.

In the next step an electrolyte composition is applied to the substrate. This
30 step is performed in a manner similar to the electrochemical patterning. The two main differences are that no voltage is applied and that the electrolyte pattern is considerably larger. Fig. 2 illustrates how the electrolyte (represented by the darker area in Fig. 2) should be printed. I.e. the

electrolyte bridges a gap between a first and a second layer of electrochemically active material, such that the two layers are in ionic contact with each other. For good device performance it is important that the electrolyte does not touch the two vertical electrochemical patterning lines to the left.

The substrate is then preferably encapsulated. Encapsulation can be performed on both wet and cured electrolyte. Encapsulation is the last step before cutting the repeated patterns into individual pages. With good encapsulation the display will be protected from external stress. Encapsulation also provides a barrier for protection against dehydration of the electrolyte.

The electrochemical device or the one-pixel electrochromic display described hereinabove is a simple electrochemical cell containing two PEDOT:PSS electrodes connected via an electrolyte. When a potential is applied between the electrodes an electronic current in the electrodes is converted to an ionic current in the electrolyte via electrochemistry occurring at both electrodes at the same time. This current will continue to flow until the electrochemical capacity of one of the electrodes has been consumed. Fig. 3 shows such a device. The PEDOT in the anode (positively addressed here) is further oxidised (from the partially-oxidised initial state) so that it becomes more conductive and optically transparent. On the other hand, the cathode (negatively addressed here) is reduced and becomes less conductive and obtains an opaque deep blue colour (shown as the darker areas in Fig. 3). The electrochemical reaction normally starts in a portion of the electrochemically active material where the electrolyte covered separation between the two layers is most narrow, i.e. where the ion path between the two electrochemically active layers is the shortest.

The left-hand picture in Fig. 3 shows the pixel switched the correct or most normal way. The cathode (negatively addressed here) under the electrolyte turns blue due to reduction when a potential of 3 V is applied. When the

whole cathode is reduced the electrochemical reaction ceases. By reverting the potential, the ion transport will run in the opposite direction and a switched pixel, as illustrated in Figure 2, may be switched back to its initial or neutral state; unless the previous reaction has irreversibly oxidised portions of the electrochemically active layer. The right-hand picture shows how the display starts to be coloured when the reaction continues from the neutral state when the potential is applied in the reverse direction compared to the situation illustrated in the left-hand picture. In this example, the minimum applied voltage for making a switch is from 0.6 to 0.9 V. The necessary voltage depends e.g. on the selected materials and their sizes.

The electrochromic device described hereinabove has a memory; it is bi-stable. This means that when the potential is removed from the display, it stays switched for up to several hours. The length of the memory time depends on the leakage current between the electrodes. This bi-stability makes it ideal for low-power applications.

Of the two electrolytes used in the process described hereinabove, the second electrolyte must retain its electrolytic function for the lifetime of the device in order for the device to be able to change its electrochemical and/or electrochromic (i.e. optical) state. Throughout the lifetime of the device, therefore, the electrolyte must allow for the confined transport of ions within the device.

By employing the same manufacturing process described hereinabove, it is possible to create other devices, such as transistors, from the same materials as the displays, as is known from e.g. US 10/819 306, US 10 496 653, WO 03/25953 and WO 05/27599, and which will be exemplified below.

Figures 4A and 4B schematically show a top view and a side view, respectively, of a bi-stable transistor. The side view is taken along the line I-I. The transistor comprises a source contact 1, a drain contact 2 and a transistor portion 3, which have all been formed from a continuous piece of

electrically conductive and electrochemically active material. Both the source and drain contacts are in electrical contact with an external power source, which allows the application of a voltage V_{ds} between them. The transistor further comprises a gate electrode 4, which can be formed from the same material as the source and drain contacts and the electrochemically active element. The gate electrode 4 is in electrical contact with an external power source, which allows applying a voltage V_g between the gate electrode and the electrochemically active element. This can be realized by applying V_g between the gate 4 and the source 1 or the drain 2, or directly between the gate 4 and the transistor portion 3. All of these components of electrochemically active material have been deposited in one layer on a support 6. On top of this layer, covering or overlapping a portion of the gate electrode 4 and covering or overlapping a portion of the active element 3, is a layer of electrolyte composition 5. Furthermore, the electrolyte layer 5 is covered with an encapsulating layer 7.

Working principle for the polarity of V_g shown in Figure 4A, and in the case of an electrochemically active material which is conducting in its oxidized state and non-conducting when reduced to its neutral state: when a gate voltage V_g is applied between the gate electrode 4 and the electrochemically active element 3, the gate electrode is polarized positive (anode), and the electrochemically active element is polarized negative (cathode). This leads to onset of electrochemistry in the electrochemically active element and at the gate electrode; the organic material in the transistor channel is reduced at the same time as an oxidation reaction takes place at the gate electrode. The reduced material in the transistor channel displays a drastically diminished electrical conductivity, which results in the closure of the transistor channel and an effective reduction of the current between source and drain for a given source-drain voltage V_{ds} , i.e. the transistor is in an "off" mode. When the external circuit supplying voltage to the gate electrode and the electrochemically active element is broken, the oxidation state of the transistor channel is substantially maintained.

Thus, the bi-stable transistor has a memory-function: It is possible to switch on or off the transistor channel with short pulses of gate voltage, V_g , applied to the gate. The respective conductivity states remain when gate voltage is removed (a zero-power device). Further adjustments of conduction characteristics in the transistor portion, or resetting thereof to the initial, high conductivity mode, can be performed by applying different voltages to the gate electrode. For an electrochemically active material which is conducting in its reduced state and non-conducting when it is oxidised, the polarity is preferably reversed.

An example of a three-terminal electrochemical transistor 500 is illustrated in Figure 5 (top view on left and side view on right). The electrochemically active element 501 comprises a thin channel 507 of PEDOT:PSS on top of which the electrolyte composition 502 is deposited. The electrolyte 502 thus defines a transistor channel or transistor portion 503. The area of the transistor channel may, for example, be $0.5 * 0.5 \text{ mm}^2$, and the thickness may be $0.2 \mu\text{m}$ (for example using OrgaconTM EL350 foil from AGFA). The electrolyte composition 502 overlaps a more than ten times larger area on the gate electrode compared to the size of the transistor channel. This is advantageous as it prevents over-oxidizing the gate electrode. I.e. it prevents an irreversible oxidation of the gate electrode. The enlarged areas of the three terminals (i.e. the gate electrode 504, the source contact 505, and the drain contact 506) are used as "pad areas" to allow easy connection to the device.

The narrow parts 507 of the electrochemically active element that extend outside the transistor channel are kept to a minimum in order to minimize the on-resistance of the transistor. However, the existence of such parts 507 is advantageous for two reasons. First, they allow some mis-alignment of the electrolyte. The second reason is that the transistor channel reduction has a tendency to migrate somewhat outside the electrolyte-covered area. In order to limit the build up of permanently reduced areas, this spreading process should be as confined as possible. To this end, each of the two extended

portions 507 may have about the same size as the electrolyte-covered part of the transistor channel. Using PEDOT:PSS as organic material, and the dimensions given above, each of these extended portions show a resistance of about 1 kOhm.

5

The embodiments illustrated in Figures 1 to 5 are examples of a lateral devices, wherein a first layer of electrochemically active material is arranged to the side of an electrolyte covered portion of a second layer of electrochemically active material. Alternatively, a vertical design may be used, wherein the electrolyte is sandwiched between a first and a second layer electrochemically active material. In other words, in the vertical transistor the gate electrode is positioned on-top of the transistor channel. The main differences between vertical and lateral devices are illustrated in Figure 6 (top view to the left and side view to the right). In the vertical configuration the electrolyte 605 is sandwiched between at least a portion of the gate electrode 603 and at least a portion of the electrochemically active material 604. The source and drain electrodes 801, 802 are typically arranged in the same plane as the transistor channel 604. In general, vertical transistors enable faster injection of ions into the transistor channel.

10
15
20

In other words, the above described transistors operate according to the same principle as the devices described in US 10/819 306. Thus, a device in accordance with the invention may be arranged as described in US 10/819 306, US 10 496 653 WO 03/25953 or WO 05/27599, except that the inventive electrolyte composition should be used as electrolyte, possibly in combination with other compositions.

25

In the printing process it is common to consider the electrolyte as a type of ink (although, for some arrangements of the display device, it must be transparent and hence does not contain any colouring agent). As is known to the man skilled in the art, the transparency of the electrolyte is primarily an issue when the display or the electrochromic element is to be viewed through the electrolyte. In other applications, such as non-display applications (where

30

the electrochemical device is arranged as e.g. a transistor or a sensor); or when the electrolyte is arranged on the back side of a display (e.g. when the electrochromic element is sandwiched between the substrate and the electrolyte, and display is viewed through the substrate); or when the electrolyte is arranged between the substrate and the electrochromic element, and the side of the display which faces away from the substrate is viewed; the transparency of the electrolyte is of less importance. Moreover, when the electrochemical device is not acting as a display it may be protected under a non-transparent layer, and the electrolyte may be non-transparent (i.e. absorbing and/or reflecting). Moreover, an electrochemical display may be arranged under a semi-transparent protective layer.

Printability is an important factor for the electrolyte, although the primary purpose of the electrolyte is to be conductive over the lifetime of the device. It is relatively straightforward to produce a conductive electrolyte, but to combine this with a long lifespan and printability is a more complex problem. One important parameter for the printability is the viscosity of the electrolyte composition. If the viscosity is too low, the printed electrolyte will not be confined to the desired area. If the viscosity is too high, there might be difficulties in feeding the electrolyte through the printing device. Thus, the viscosity of the printable electrolyte is preferably adapted to the intended printing device. Preferably, the viscosity is at least 0.3 Pas, or more preferably at least 0.5 Pas such that it can be printed by means of screen printing. Normally, if a composition with a lower viscosity is used for screen printing, the same area has to be printed repeatedly in order for an electrolyte with the desired/working thickness to be reached. Consequently, to be able to pattern the electrolyte on the electrochromic display it needs to be in liquid form. The electrolyte must contain ions in some form, a solvent and a medium to bind the material into a gel or solid after printing, which makes the electrolyte both conductive and printable. It is typically difficult to combine these requirements with parameters such as compatibility with adjacent materials, adhesion, scratch resistance, transparency, printability, curing and electrical properties.

US 6,395,043 discloses an electrolyte formulated as a printing ink. The ink is laid down by an in-line press and is cured thermally or by UV irradiation. The ink is based on the curing of a monomer, such as acrylic acid, and contains water, an electrolyte, such as KCl, and a thickening agent. Although a thickening agent is present, it is present at less than 1% by weight and hence this electrolyte will have a very low viscosity which would make it unsuitable for most commercially viable manufacturing techniques. Techniques for increasing the viscosity without adversely affecting the other properties of the electrolyte are not disclosed.

10

US 7,022,264 discloses a solid polymer electrolyte which is applied in the form of a polymerisable composition. The polymerisable composition is formulated with a non-aqueous organic solvent to provide a composition having a low water content. Again, this electrolyte will have a low viscosity.

15

US 2005/0068603 discloses a solidified electrolyte which is applied as a liquid which is subsequently solidified by evaporation of solvent or by curing, or is applied as a solid polymeric electrode. Minimal detail is provided regarding the composition of the solidified electrolyte.

20

US 7,119,937 discloses electrolyte solutions for electrochromic devices and specifically techniques for decolouring such solutions. There is no disclosure of printable and curable compositions.

25 There remains a requirement in the art, therefore, for an electrolytic composition which provides a balance between printability and electrolytic properties.

According to one aspect thereof, the present invention provides a printable electrolyte composition for the production of electrochemical devices comprising:

30

(i) 20-50% by weight, based on the total amount of the composition, of a radiation-curable base which comprises

- (a) a radiation-curable water-compatible (meth)acrylate oligomer,
(b) a (meth)acrylate monomer,
(c) a photoinitiator, and
(ii) 20-50% by weight, based on the total amount of the composition, of
5 solvent; and
(iii) 10-50% by weight, based on the total amount of the composition, of an
electrolyte,
wherein the composition has a viscosity of 0.3 Pas or higher.
- 10 According to a second aspect thereof the present invention provides a
printable electrolyte composition for the production of electrochemical devices
comprising:
20-50% by weight, based on the total amount of the composition, of a
thermally curable base which comprises a resin;
15 20-50% by weight, based on the total amount of the composition, of solvent;
and
10-50% by weight, based on the total amount of the composition, of an
electrolyte, wherein the composition has a viscosity of 0.3 Pas or higher.
- 20 According to a third aspect thereof, the present invention provides a method
of manufacturing an electrochemical device comprising the steps of:
providing a substrate;
arranging a first and a second layer of electrochemically active material
on said substrate, wherein said layers are spatially separated from each
25 other;
printing a layer of electrolyte composition in ionic contact with both said
first and second layer of electrochemically active material, such that said first
and second layers are ionically connected, wherein the electrolyte
composition is arranged in accordance with said first or second aspect of the
30 invention, and
curing said electrolyte.

In the context of the invention curing encompasses the act of drying the electrolyte by means of e.g. irradiation by light or by thermal heating.

5 Preferably, said substrate is flexible, and arranged of paper or plastic or a combination thereof.

According to one embodiment the device is cured by irradiating said electrolyte composition by actinic radiation and preferably UV-radiation, alternatively the electrolyte is cured by means of thermal radiation.

10

According to a fourth aspect thereof, the present invention provides a electrochemical device comprising:

a flexible substrate;

15 a first and a second layer of electrically conductive and electrochemically active material, which layers are spatially separated from each other and carried by said flexible substrate,

20 an electrolyte composition, resulting from the drying of an electrolyte composition arranged in accordance with said first or second aspect of the invention, which electrolyte composition ionically connects said first and second layer;

wherein the redox state and the electrical conductivity of said first layer is controllable by means of a voltage applied across said electrolyte.

25 According to one embodiment the device has a vertical structure, wherein the electrolyte composition is sandwiched between said first and second layers of electrochemically active material. This is advantageous as a vertical structure normally provides a less energy consuming device with faster switching times. The shorter response times are e.g. due to that the average ion path between said first and second layers are shorter.

30

According to an alternative embodiment, the device has a lateral structure i.e. the electrolyte composition is in ionic contact with a respective surface of said first and second layers, wherein said surfaces face the same direction. In

other words, in a lateral structure the first layer of electrochemically active material is arranged to the side of a second layer of electrochemically active material. According to one embodiment said first and second layers are arranged in a common plane.

5

Preferably, the electrolyte composition overlaps or covers at least a respective portion of said first and second electrochemical layer. According to one embodiment the electrolyte composition covers only a portion of said first layer and only a portion of said second layer. According to an alternative
10 embodiment the electrolyte composition covers substantially the whole of said first and/or second layer.

Optionally, two or more electrochemical devices may be stacked on top of each other, wherein two neighbouring devices preferably are separated by an
15 isolating layer.

The at least one of said first and second layer is preferably arranged of electrically conductive polymer, which may or may not be electrochromic. The electrically conductive polymer is preferably arranged as a conductive
20 polymer film.

Optionally, the device may be provided with an encapsulation covering the electrolyte, e.g. in such a manner as was described above. This is particularly advantageous when the solvent comprises water and a ionic solid is used a
25 electrolyte, as the encapsulation ensures the water content of the composition which normally improves the ionic conductivity. The two most preferred encapsulation techniques used are varnishing and lamination. The printing of a varnish is advantageous as it facilitates the application of the protective layer locally on the substrate. Laminates are advantageous as they some
30 times are more easy to handle. By way of an example, polypropylene (PP) tape may be laminated over the electrolyte. Preferably, the encapsulation protects the device from deteriorating interaction with UV-radiation. A protection against UV-radiation can be achieved by adding UV-absorbers to

the varnish, or by using an UV-absorbing laminate as encapsulation. Further, the encapsulation is preferably flexible and compatible with rest of the components.

- 5 The composition described in relation to the above aspects of the invention allows for the printing or deposition of an electrolyte that preferably cures almost instantly, is mechanically stable, has good adhesion to e.g. a layer of conductive polymer, has the ability to retain a solvent such as water and provides an electrochromic device and/or electrochemical device having a
10 long lifetime and good performance (short switch time) under all ambient conditions (in particular low relative humidity).

According to one embodiment of the invention the composition is thermally curable. In relation to this invention, this means that solidification and
15 insolubilization of the print-deposited composition takes place as a consequence of evaporation of the solvents from the composition, either at ambient temperature or at elevated temperatures.

Suitable solvents for the thermally cured electrolyte composition may e.g. be
20 selected from a group comprising: aromatic hydrocarbons, aliphatic hydrocarbons, ketones, esters, glycol ethers, glycol ether esters, butyl oxitol, butyl oxitol acetate, butyl propanol acetate, ethyl propyl acetate, methoxy propanol, water and combinations thereof. Specific examples of suitable solvents comprise: whitespirit, Shellsol A, Shellsol 150, Shellsol 200, Shellsol
25 T, SBP6, SBP11, cyclohexanone, butyrolactone and distilled water. Dependent on the specific selection of solvent or combination of solvents, e.g. the drying speed and adhesion can be adjusted.

When water is used as solvent, a combination of a thickener, which raises the
30 viscosity, and a wetting agent, which lowers the surface tension, is advantageously added to the composition. This is useful both for radiation curable and thermally curable electrolyte compositions, and both for electrolytes comprising ionic liquids and ionic solids or a combination of

these. According to one embodiment the resin is provided as an emulsion in water, comprising a thickener and a wetting agent. Examples of suitable wetting agents are given below, in relation to the radiation curable electrolyte composition. Preferably the wetting agent is present from 0.1 to 20% by weight, preferably from 1 to 10% by weight, of the curable base.

According to one embodiment the amount of solvent in the thermally curable composition is between about 40% and about 70% by weight, based on the total weight of the curable base. If too much solvent is used, the conductivity per surface area of the printed electrolyte will not be sufficient.

According to one embodiment the electrolyte of the thermally cured electrolyte composition comprises an ionic liquid. Ionic liquids or ionic liquid solutions are advantageous as they normally provide a significantly longer life time of the electrochemical device, and may be ionically conductive also at low relative humidity. In other words, ionic liquids can provide a good ionic conductivity although the amount of solvent in the electrolyte composition after curing is very low. As used herein, the term ionic liquid solution includes mixtures of ionic liquids and solutions of ionic solids dissolved in an ionic liquid. An example of the latter solution is LiClO₄ dissolved in [BMIM] [BF₄]. Further, examples of conjugated polymers suitable for use in electrochemical devices are e.g. the polymers : polyphenylene, polyphenylenevinylene, polyphenylenesulfide, polyfluorene, polypyridine, polypyridalvinylene, polypyrrole, polyaniline, polythiophene, polythiophenevinylene, polyfuran, polyacetylene, polyquinone, polyantraquinone, polycarbazole, polyindole, pollythioazole and derivatives thereof. Moreover, ionic liquids may also based on various monocations, such as pyridinium, pyridazinium, pyrimidinium, pyraxinium, imidazolium, pyrazolium, thiazolium, oxazolium, triazolium, ammonium, pyrrolidinium, pyrrolinium, pyrrolium, piperidinium. Additionally, ionic liquids may also be based on various polycations, such as polypyrrole, polyaniline, polythiophene, polythiophenevinylene, polyfuran, polyquinone.

Figure 7b illustrates the performance of an electrochromic device comprising an electrolyte composition according to the invention, where the electrolyte is NaCl. The electrolyte device was formed as described in relation to Figure 1-3. The graph illustrates that the device deteriorates quickly, i.e. the switching speed increases from about 6 s to about 45 s already after four days.

Figure 7a illustrates the performance of a two devices, which each are equal to the device used in relation to the experiment which is illustrated in Figure 7b except that in both devices the electrolyte was ionic liquid (EMIM-ES) and not NaCl. The graph clearly shows that the switching time of the device is remains substantially the same (i.e. within 2 - 3.5 s) for a period of more than 50 days. Consequently, an electrochemical device comprising ionic liquids provides a low switching time substantially longer compared to ionic liquids.

According to another embodiment the electrolyte is an ionic solid. Thus, the electrolyte may be an ionic solid or an ionic liquid and may be organic or inorganic. The electrolyte may be an inorganic electrolyte such as and alkali metal halide, e.g. KCl. Organic electrolytes may contain an organic cation, such as a quaternary ammonium and/or phosphonium salts having alkyl and/or aryl substituents, optionally further substituted, e.g. with halo, alkyl (C₁-C₈), hydroxyl, amine, etc.), e.g. tetrabutyl, tetraoctyl, or tetracetylammonium salts; or a nitrogen-containing heterocycle, such as imidazolium or pyridinium, e.g. methyl-octyl-imidazolium chloride, butyl-methyl-imidazolium-bis-trifluoromethane sulfonimide. Alternatively or in addition the organic electrolytes may contain an organic anion, such as alkylsulfate, trifluorocarboxylic acid, organic sulfonate, organic phosphate or organic phosphonate. Counter ions for the organic cations include halides (chlorides, iodides, bromides, fluorides), nitrates, nitrites, tetrafluoroborates, hexafluorophosphates, trifluoromethanesulfonates and other polyfluoroalkanesulfonates, e.g. nonaflate, bis(trifluoromethylsulfonyl)imides, methylsulfates, acetates, fluoroacetates and other anions of fluoroalkanoic acid. The electrolyte is retained in the cured composition and an electrolyte

cured by actinic radiation hence must be stable in the presence of said radiation used to cure the composition.

5 According to one embodiment the electrolyte is an ionic solid and the solvent comprises water. This is advantageous, as there is a wide range of water-soluble ionic solids which provides good high ionic conductivity.

According to one embodiment, the present invention provides an electrolyte composition for an electrochromic device comprising

- 10 (i) 20-50% by weight, based on the total amount of the composition, of a radiation-curable base which comprises
- (a) a radiation-curable water-compatible (meth)acrylate oligomer,
 - (b) a (meth)acrylate monomer,
 - (c) a photoinitiator, and
 - 15 (d) a wetting agent;
- (ii) 20-50% by weight, based on the total amount of the composition, of water; and
- (iii) 10-50% by weight, based on the total amount of the composition, of an electrolyte,
- 20 wherein the composition has a viscosity of 0.5 Pas or higher.

The composition of the present invention thus comprises the following components: a curable base, solvent and an electrolyte. Each of these components will be considered in turn.

25

According to one embodiment the radiation curable base contains a radiation-curable (meth)acrylate oligomer, a (meth)acrylate monomer, a photoinitiator and preferably a wetting agent. The (meth)acrylate oligomer is preferably water-compatible. The composition contains at least 20% by weight,

30 preferably at least 30% by weight and most preferably at least 35% by weight, and 50% or less by weight, preferably 45% or less by weight, of curable base based on the total amount of the composition. According to one embodiment the oligomer is present at 40-95% by weight, based on the total amount of the

curable base. The radiation-curable (meth)acrylate oligomer is a curable oligomeric component and such materials are commercially available. One or more oligomers may be used. The oligomer may be selected from a polyester (meth)acrylate, an epoxy (meth)acrylate, a urethane (meth)acrylate or mixtures thereof. A urethane (meth)acrylate is particularly preferred and examples include Craynor CNSP061 (a water-soluble aliphatic urethane acrylate supplied by Sartomer having Mw 7800), Craynor CNSP066 (a water-soluble aliphatic urethane acrylate supplied by Sartomer having Mw 6000), Photocryl DP266 (an 80:20 mix of water-soluble aliphatic urethane acrylate and DPGDA supplied by PC Resin GmbH) and IRR569 (an acrylated resin supplied by Cytec).

The term "oligomer" has its standard meaning in the art, namely that the component is partially polymerised to form a pre-polymer which is capable of further polymerisation. The oligomers of the present invention has a weight-average molecular weight (Mw) of 500-25,000. Preferably the weight-average molecular weight is 750 or higher and most preferably 1000 or higher. Preferably the weight-average molecular weight is 15,000 or less, more preferably 10,000 or less and most preferably 8,000 or less. The Mw may be measured by known techniques in the art, such a gel permeation chromatography (GPC).

A suitable GPC apparatus for measuring Mw is an LC instrument having the following parameters - Column set: MiniMix E or MiniMix D (depending on molecular weight), Eluent: THF, Detector: UV/vis and/or ELS, Calibration: conventional vs polystyrene. This approach is applicable to polymers having a Mw of 400-400,000.

By water-compatible is meant that the oligomer is either soluble in water or capable of forming a stable suspension, i.e. a dispersion which does not separate (settle), i.e. the radiation-curable water-compatible (meth)acrylate oligomer has a water compatibility such that the oligomer is soluble in water or is capable of forming a stable dispersion in water. The water compatibility

is therefore a function of the chemical nature and the amount of the oligomer. Only oligomers which are water-soluble or dispersible in the amount used in the composition are suitable for use in the present invention. For example, DP266 is soluble in water up to about 300g/L and beyond that quantity the product will emulsify but form a stable dispersion (i.e. no separation). Only
5 beyond about 500 g/L will the dispersion become unstable. Thus, provided that the DP266 is used in an amount within the soluble or stably dispersible range, it is suitable for use in the present invention. Preferably the oligomer has a water solubility of at least 50 g/L, more preferably at least 100 g/L
10 measured at 25°C.

The oligomer may be mono or multifunctional (preferably di, tri, or tetrafunctional). Mono and multifunctional are intended to have their standard meanings, i.e. one and two or more groups, respectively, which take part in
15 the polymerisation reaction on curing. Such materials are well-known in the art.

The composition preferably contains 40 to 95% by weight of oligomer based on the total weight of the curable base. Preferably the composition contains at
20 least 50% by weight and most preferably at least 60% by weight, based on the total weight of the curable base. Preferably the composition contains 90% or less by weight and most preferably 85% or less by weight, based on the total weight of the curable base.

25 The composition of the present invention also contains one or more radiation-curable (meth)acrylate monomers. The monomer may be multifunctional or monofunctional or a mixture thereof. Mono and multifunctional are intended to have their standard meanings, i.e. one and two or more groups, respectively, which take part in the polymerisation reaction on curing. Such materials are
30 well-known in the art.

Examples of the multifunctional acrylate monomers which may be included in the composition of the present invention include hexanediol diacrylate,

trimethylolpropane triacrylate, pentaerythritol triacrylate, polyethylene glycol diacrylate, for example, tetraethylene glycol diacrylate), dipropylene glycol diacrylate, tri(propylene glycol) triacrylate, neopentyl glycol diacrylate, bis(pentaerythritol) hexaacrylate, and the acrylate esters of ethoxylated or propoxylated glycols and polyols, for example, propoxylated neopentyl glycol diacrylate, ethoxylated trimethylolpropane triacrylate, and mixtures thereof.

In addition, suitable multifunctional acrylate monomers include esters of methacrylic acid (i.e. methacrylates), such as hexanediol dimethacrylate, trimethylolpropane trimethacrylate, triethyleneglycol dimethacrylate, diethyleneglycol dimethacrylate, ethyleneglycol dimethacrylate, 1,4-butanediol dimethacrylate.

The monofunctional (meth)acrylate monomers are also well known in the art and are preferably the esters of acrylic acid. Preferred examples include phenoxyethyl acrylate (PEA), cyclic TMP formal acrylate (CTFA), isobornyl acrylate (IBOA), tetrahydrofurfuryl acrylate (THFA), 2-(2-ethoxyethoxy)ethyl acrylate, octadecyl acrylate (ODA), tridecyl acrylate (TDA), isodecyl acrylate (IDA) and lauryl acrylate

Mixtures of (meth)acrylates may also be used. Water-solubility is not essential for the monomer since the water-compatibility of the oligomer assists with the incorporation of the monomer into the composition. However, the monomer is preferably water-soluble. Preferably the monomer has a solubility of at least 50 g/L, more preferably at least 100 g/L measured at 25°C, and most preferably the monomer is water-miscible, i.e. soluble in water in all proportions. The weight-average molecular weight is typically below 500.

The total amount of the (meth)acrylate monomer present in the composition is preferably at least 3% by weight, more preferably at least 5% by weight, based on the total weight of the curable base, and preferably no more than 30% by weight, more preferably no more than 25% by weight, most preferably no more than 20% by weight based on the total weight of the base. According

to one embodiment the monomer is present at 3-30% by weight, based on the total amount of the curable base.

5 (Meth)acrylate is intended herein to have its standard meaning, i.e. acrylate and/or methacrylate.

In addition to the monomers described above, the radiation-curable base include a photoinitiator, which, under irradiation, for example with UV light, initiates the polymerisation of the monomers and oligomers. Preferred are
10 photoinitiators are free radical photoinitiators, such as benzophenone, 1-hydroxycyclohexyl phenyl ketone, 2-benzyl-2-dimethylamino-(4-morpholinophenyl)butan-1-one, benzil dimethylketal, bis(2,6-dimethylbenzoyl)-2,4,4-trimethylpentylphosphine oxide or mixtures thereof. Such photoinitiators are known and commercially available such as, for
15 example, under the trade names Irgacure, Darocur (from Ciba) and Lucerin (from BASF). The wavelength of the radiation and the nature of the photoinitiator system used must of course coincide.

The photoinitiator may be used in the presence or absence of a synergist.
20 Preferably the composition does not contain a synergist. Amine-containing synergists have a tendency to discolour the composition and should preferably be avoided.

Preferably the photoinitiator is present from 1 to 20% by weight, preferably
25 from 8 to 12% by weight, of the curable base.

Preferably, the composition also contains a wetting agent. Examples include silicone oils, such as Dow Corning 200, 300, etc; modified siloxanes, modifications include amino, polyester, polyether, available from Tego, BYK
30 Chemie etc.; fluoro surfactants, such as Zonyl FSN available from DuPont; mineral oils, such as BYK-035 available from BYK Chemie; non-ionic organic surfactants such as Tego Wet 510 from Tego; and polymeric additives, such as acrylic copolymers such as Modarez MFP from Synthron. The wetting

agent improves the planerisation and the split of the printed ink. The wetting agent also contributes to the retention of the water or solvent in the cured composition.

- 5 Preferably the wetting agent is present from 0.1 to 20% by weight, preferably from 1 to 10% by weight, of the curable base.

The composition contains a solvent, e.g. an organic solvent or water. The solvent forms part of the liquid vehicle of the composition. In addition, the
10 solvent is present after curing of the composition allowing the movement of ions (of the electrolyte) through the composition. The solvent, e.g. water is present at 20-50% by weight, preferably 30-40% by weight based on the total amount of the composition. The solvent might be an organic solvent or water, or a combination an organic solvent and water.

15

For UV-radiation curable electrolyte compositions suitable solvents, besides water, are e.g. glycolethers and glycoether acetates. Preferably, the solvent is highly oxygenated such in order to prolong the lifetime of the UV radiation source, by avoiding the build up of carbon deposits on the external surface of
20 the UV radiation source.

The presence of a water-compatible oligomer, a water-soluble monomer and a wetting agent in the curable base is advantageous as it leads to the retention of significant quantities of water in the cured composition. The
25 amount retained is sufficient to allow for the confined transport of ions within the cured electrolyte composition.

As used herein the term electrolyte normally refers to a substance that at least when dissolved in a suitable solvent is or becomes an ionic conductor.
30 Further, the term electrolyte composition refers to a solution comprising the electrolyte. In order to facilitate the reading the term electrolyte is sometimes used instead of electrolyte composition.

The electrolyte may be an ionic solid or an ionic liquid and may be organic or inorganic. The electrolyte may be an inorganic electrolyte such as and alkali metal halide, e.g. KCl. Organic electrolytes may contain an organic cation, such as a quaternary ammonium and/or phosphonium salts having alkyl and/or aryl substituents, optionally further substituted, e.g. with halo, alkyl (C₁-C₈), hydroxyl, amine, etc.), e.g. tetrabutyl, tetraoctyl, or tetracetylammonium salts; or a nitrogen-containing heterocycle, such as imidazolium or pyridinium, e.g. methyl-octyl-imidazolium chloride, butyl-methyl-imidazolium-bis-trifluoromethane sulfonimide. Alternatively or in addition the organic electrolytes may contain an organic anion, such as alkylsulfate, trifluorocarboxylic acid, organic sulfonate, organic phosphate or organic phosphonate. Counter ions for the organic cations include halides (chlorides, iodides, bromides, fluorides), nitrates, nitrites, tetrafluoroborates, hexafluorophosphates, trifluoromethanesulfonates and other polyfluoroalkanesulfonates, e.g. nonaflate, bis(trifluoromethylsulfonyl)imides, methylsulfates, acetates, fluoroacetates and other anions of fluoroalkanoic acid. The electrolyte is retained in the cured composition and an electrolyte cured by actinic radiation hence must be stable in the presence of said radiation used to cure the composition.

20

Ionic liquids or ionic liquid solutions are advantageous as they provide a significantly longer life time of the electrochemical device, and may be ionically conductive also at low relative humidity. As used herein, the term ionic liquid solution includes mixtures of ionic liquids and solutions of ionic solids dissolved in an ionic liquid. An example of the latter solution is LiClO₄ dissolved in [BMIM] [BF₄]. Further, examples of conjugated polymers suitable for use in electrochemical devices are e.g. the polymers : polyphenylene, polyphenylenevinylene, polyphenylenesulfide, polyfluorene, polypyridine, polypyridalvinylene, polypyrrole, polyaniline, polythiophene, polythiophenevinylene, polyfuran, polyacetylene, polyquinone, polyantraquinone, polycarbazole, polyindole, pollythioazole and derivatives thereof. Moreover, ionic liquids may also based on various monocations, such as pyridinium, pyridazinium, pyrimidinium, pyraxinium, imidazolium,

30

pyrazolium, thiazolium, oxazolium, triazolium, ammonium, pyrrolidinium, pyrrolinium, pyrrolium, piperidinium. Additionally, ionic liquids may also be based on various polycations, such as polypyrrole, polyaniline, polythiophene, polythiophenevinylene, polyfuran, polyquinone.

5

The electrolyte is present at 10-50% by weight, preferably 20-40% by weight. Electrolytes are well-known in the art. The electrolyte is preferably hygroscopic to assist in retaining water in the cured composition.

10 According to one embodiment the composition of the present invention is transparent after curing. This is advantageous when the display is viewed through the electrolyte and maximum contrast is desired. Since the electrolyte is used as part of an electrochromic device and the cured electrolyte must be sufficiently transparent to allow the user to see the colour change in the
15 conductive film below. By transparent is meant transparent to the user, i.e. under visible light. Accordingly, the composition is substantially free of colouring agents, including both dissolved and dispersed colouring agents (pigments, dyes etc). By substantially free is meant that traces of colouring agents may be tolerated provided they do not interfere with the visualisation
20 of the colour change occurring in the conductive film. Considerable effort has been expended in finding materials which have the balance of printability and electrolytic properties but which are still transparent after curing.

25 According to another embodiment, the electrolyte is non-transparent or semi-transparent. Such electrolytes are normally not used for the display applications where the display is viewed through the electrolyte, but for other display applications and for other types of electrochemical components.

30 Other components of types known in the art of ink formulation may be present in the thermally curable or radiation curable compositions to improve the properties or performance. These components may be, for example, defoamers, rheology modifiers, synergists for the photoinitiator, stabilisers

against deterioration by heat or light, reodorants, biocides etc. The requirement for transparency must, however, be met.

5 The composition of the present invention has a viscosity of at least 0.5 Pas (5 poise), more preferably at least 1 Pas (10 poise) and most preferably about 2.5 Pas (25 poise) at 25°C, prior to curing. Viscosity may be determined using a Sheen Rotothinner available from Sheen Instruments operating at a shear rate of 80 s⁻¹. The control over the viscosity may be achieved by balancing the amount of oligomer and thickening agent (increases the viscosity), and
10 the monomer and water or solvent (decrease the viscosity).

The electrolyte may be printed using a range of printing methods including flexo, screen, offset and gravure printing. Screen printing is particularly preferred.

15

The composition of the invention may be prepared by known methods such as, for example, stirring with a high-speed water-cooled stirrer, or milling on a horizontal bead-mill.

20 The present invention also provides a method of manufacturing an electrochromic device comprising the steps of providing a substrate having a patterned conductive polymer film thereon, printing the electrolytic composition as described herein on to the film and heating the composition or irradiating the composition with actinic radiation to cure the composition. The
25 cured film contains components not previously disclosed in an electrochromic device and hence the present invention also provides an electrochromic device per se which is obtainable by the above-described method.

30 According to an alternative manufacturing process the electrolyte composition is provided on the substrate, before the electrochemically active material is arranged thereon.

Examples

The electrolyte composition of the invention will now be described, by way of example, with reference to the following example (parts given are by weight).

5 Example 1

A UV-curable base for formulating a composition according to the present invention was prepared by combining the following components in the following quantities.

10	<u>Component</u>		<u>wt%</u>
	CN SP061	(Oligomer)	68.15
	Craynor 434	(Acrylate monomer)	7.13
	Irgacure 184	(Photoinitiator)	3.72
	Lucerin TPO	(Photoinitiator)	3.72
15	Benzophenone	(Photoinitiator)	3.72
	PEG 1500	(Humectant)	3.72
	Caflon PHC080	(Surfactant)	1.67
	Silicone Fluid	(Flow aid)	1.86
	Aerosil 200	(Rheology modifier)	1.1
20	Byk defoamer 035	(Flow aid)	0.56
	Alcoprint PTF	(Rheology modifier)	3.72
	Genorad 16	(Stabilizer)	0.93

	100.0		

25

Example 2

A UV-curable base for formulating a composition according to the present invention was prepared by combining the following components in the following quantities.

30

	<u>Component</u>	<u>wt%</u>
	CN SP066	68.15
	Craynor 434	7.13

	Irgacure 184	3.72
	Lucerin TPO	3.72
	Benzophenone	3.72
	PEG 1500	3.72
5	Caflon PHC080	1.67
	Silicone Fluid	1.86
	Aerosil 200	1.1
	Byk defoamer 035	0.56
	Alcoprint PTF	3.72
10	Genorad 16	0.93

	100.0	

Example 3

- 15 A UV-curable base for formulating a composition according to the present invention was prepared by combining the following components in the following quantities.

	<u>Component</u>	<u>wt%</u>
20	DP266	68.15
	Craynor 434	7.13
	Irgacure 184	3.72
	Lucerin TPO	3.72
	Benzophenone	3.72
25	PEG 1500	3.72
	Caflon PHC080	1.67
	Silicone Fluid	1.86
	Aerosil 200	1.1
	Byk defoamer 035	0.56
30	Alcoprint PTF	3.72
	Genorad 16	0.93

	100.0	

Example 4

A UV-curable base for formulating a composition according to the present invention was prepared by combining the following components in the
 5 following quantities.

	<u>Component</u>	<u>wt%</u>
	IRR569	68.15
	Craynor 434	7.13
10	Irgacure 184	3.72
	Lucerin TPO	3.72
	Benzophenone	3.72
	PEG 1500	3.72
	Caflon PHC080	1.67
15	Silicone Fluid	1.86
	Aerosil 200	1.1
	Byk defoamer 035	0.56
	Alcoprint PTF	3.72
	Genorad 16	0.93
20	-----	
	100.0	

Example 5

A particularly preferred UV-curable base for formulating a composition
 25 according to the present invention was prepared by combining the following components in the following quantities.

	<u>Component Amount</u>	<u>(g)</u>	<u>wt%</u>
	Actilane SP061	27.9	65.5
30	Craynor 435	2.88	6.7
	Irgacure 184	1.5	3.5
	Lucerin TPO	3.75	8.8
	Benzophenon	1.5	3.5

29

	PEG 1500	1.5	3.5
	Caflon PHC080	0.66	1.5
	Silicone	0.75	1.8
	Aerosil	0.45	1.1
5	Defoamer 035	0.23	0.5
	Alcprint thickener	1.5	3.5
		-----	-----
		42.62	100

10 Example 6

Two UV-curable compositions of the present invention were prepared by combining the following components.

	<u>Component</u>	<u>wt%</u>
15	UV-base	45
	Water	35
	BMIM-Cl* (CAS 79917-90-1)	20

		100.0

20

* 1-butyl-3-methyl-1H-imidazolium chloride

	<u>Component</u>	<u>wt%</u>
	UV-base	36
25	Water	36
	EMIM-ES* (CAS 342573-75-5)	27

		100.0

30 *1-ethyl-3-methyl-1H-imidazolium ethyl sulfate

The "UV-base" was the curable base from Example 5.

Example 6

A thermally curable base for formulating a composition comprising an organic solvent according to the present invention was prepared by combining the
 5 following components in the following quantities.

	<u>Component</u>	<u>wt%</u>	
	EFKA 7215	0.1	(surfactant)
	Synolac 8185 S90	7.1	(resin)
10	N/C chip H22.5 in 20% ATBC *	21.1	(resin)
	Solvent Naphta 160/185	2.1	(solvent)
	Isopropyl oxitol acetate	3.2	(solvent)
	Methoxy Propanol	13.2	(solvent)
	Propyl Glycol	13.2	(solvent)
15	EMIM-ES**	20	(electrolyte)

		100.0	

*ATBC = Acetyl TriButyl Citrate

20 ** EMIM-ES = 1-Ethyl-3-methylimidazolium ethyl sulfate, CAS number [342573-75-5]

According to an alternative example a thinner was added to the composition
 25 described in relation to Example 6.

	<u>Component</u>	<u>wt%</u>	
	ZC 530	17.70	(thinner)
	EFKA 7215	0.13	(surfactant)
	Synolac 8185 S90	5.84	(resin)
30	N/C chip H22.5 in 20% ATBC*	17.42	(resin)
	Solvent Naphta 160/185	18.25	(solvent)
	Isopropyl oxitol acetate	2.67	(solvent)
	Methoxy Propanol	10.92	(solvent)

	31	
Propyl Glycol	10.77	(solvent)
EMIM-ES**	16.30	(electrolyte)

	100.0	

5

The invention has mainly been described above with reference to a number of explicitly disclosed embodiments. However, as is readily appreciated by a person skilled in the art, other embodiments than the ones disclosed above
10 are equally possible within the scope of the invention, as de-fined by the appended patent claims. The display may e.g. have a vertical design. The electrochemically active material need not be an organic polymer. The electrolyte may be applied to other devices than those described without leaving the scope of the invention. These devices should preferably be based
15 on the same principles as the devices described herein. The solvents are not to be limited to the specific examples given, but can be any solvent which provide suitable volatility, solvency for the resin as well as preferably provides low toxicology.

20 Generally, all terms used in the claims are to be interpreted according to their ordinary meaning in the technical field, unless explicitly defined otherwise herein. All references to "a/an/the [element, device, component, means, step, etc]" are to be interpreted openly as referring to at least one instance of said element, device, component, means, step, etc., unless explicitly stated
25 otherwise.

Claims

1. A printable electrolyte composition for the production of electrochemical devices comprising:
- 5 20-50% by weight, based on the total amount of the composition, of a thermally-curable base which comprises a resin;
20-70% by weight, based on the total amount of the composition, of a solvent;
and
10-50% by weight, based on the total amount of the composition, of an
10 electrolyte, wherein the composition has a viscosity of 0.3 Pas or higher.
2. A composition according to claim 1, wherein the electrolyte comprises ionic liquid.
- 15 3. A composition according to claim 1 or 2, wherein said solvent comprises an organic solvent.
4. A composition according to claim 3, wherein said solvent is selected from a group comprising aromatic hydrocarbons, aliphatic hydrocarbons, ketones,
20 esters, glycol ethers and glycol ether esters.
5. A composition according any one of the preceding claims, wherein the solvent comprises water.
- 25 6. A composition according to any one of the preceding claims, wherein the solvent is present at 40-70% by weight, based on the amount of the composition.
7. A printable electrolyte composition for the production of electrochemical
30 devices comprising
(i) 20-50% by weight, based on the total amount of the composition, of a radiation-curable base which comprises
(a) a radiation-curable (meth)acrylate oligomer,

(b) a (meth)acrylate monomer, and

(c) a photoinitiator,

(ii) 20-50% by weight, based on the total amount of the composition, of a solvent; and

5 (iii) 10-50% by weight, based on the total amount of the composition, of an electrolyte,

wherein the composition has a viscosity of 0.3 Pas or higher.

8. A composition according to claim 6, wherein the oligomer is present at 40-
10 95% by weight, based on the total amount of the curable base.

9. A composition according to claim 7 or 8, wherein the oligomer is a polyester (meth)acrylate, an epoxy (meth)acrylate, a urethane(meth)acrylate or mixtures thereof.

15

10. A composition according to any one of claims 7 to 9, wherein the monomer is present at 3-30% by weight, based on the total amount of the curable base.

20 11. A composition according to any one of claims 7 to 10, wherein said electrolyte is ionic liquid.

12. A composition according to any one of claims 7 to 11, wherein said solvent is water.

25

13. A composition according to claim 12, wherein said oligomer is water-compatible.

14. A composition according to claim 13, wherein the oligomer has a water
30 solubility of at least 50 g/L measured at 25°C.

15. A composition according to any one of claims 10-14, wherein the monomer is water-soluble.

16. A composition according to any one of claims 15 wherein the monomer is water-miscible.

5 17. A composition according to any one of claim 5 or 6 or 10-16, wherein the water is present at 30-40% by weight, based on the total amount of the composition.

18. A composition according to claim 6-11, wherein said solvent is organic.

10

19. A composition according to any one of the preceding claims, wherein said base further comprises a wetting agent.

20. A composition according to claim 19, wherein the wetting agent is present
15 from 0.1% to 20% by weight based on the total amount of the curable base.

21. A composition according to claim 18 to 20, wherein said solvent is a glycolether or a glycolether acetate.

20 22. A composition according to any one of the preceding claims, wherein said viscosity is 0.5 Pas or higher.

23. A composition according to any one of the preceding claims, wherein the curable base is present at 35-45% by weight, based on the total amount of
25 the composition.

24. A composition as claimed in any preceding claim, wherein the electrolyte is present at 20-35% by weight, based on the total amount of the composition.

30 25. A method of manufacturing an electrochemical device comprising the steps of:

providing a substrate

arranging a first and a second layer of electrochemically active material on said substrate, wherein said layers are spatially separated from each other,

printing a layer of electrolyte composition, arranged according to claim 5 1 or 7, in ionic contact with both said first and said second layer of electrochemically active material, such that said first and second layers are ionically connected, and
curing said electrolyte.

10 26. A method of manufacturing according to claim 25, wherein the electrolyte is arranged according to claim 7 and the step of curing said electrolyte comprises the step of irradiating said electrolyte by actinic radiation.

15 27. A method of manufacturing according to claim 26, wherein the actinic radiation is UV radiation.

28. A method of manufacturing according to claim 25, wherein the electrolyte is arranged according to claim 1 and the step of curing said electrolyte comprises the step of thermally heating said electrolyte.

20

29. A method of manufacturing according any one of the claims 25 to 28, further comprising the step of arranging an encapsulation covering said electrolyte.

25 30. A method of manufacturing according any one of the claims 25 to 29, wherein said electrochemically active material is a conductive polymer film.

31. An electrochemical device comprising:

a flexible substrate;

30 a first and a second layer of electrically conductive and electrochemically active material, which are spatially separated from each other and carried by said flexible substrate;

an electrolyte composition, resulting from the drying of the electrolyte composition arranged in accordance with claim 1 or 7, which ionically connects said first and said second layer,

5 wherein the redox state of said first layer is controllable by means of a voltage applied across said electrolyte, and wherein said first layer is arranged such that a change of redox state alters the electrical conductivity of said first layer.

10 32. A device according claim 31, wherein said electrolyte composition is sandwiched between said first and second layer.

15 33. A device according to claim 32, wherein said electrolyte composition is in contact with a respective surface of said first and second layer, wherein said surfaces faces the in same direction.

34. A device according to any one of claims 31-34, wherein said first electrochemically active material is arranged to the side of said first electrochemically active material.

20 35. A device according to any one of claims 31-34, wherein said electrolyte composition overlaps a portion of said first electrochemically active material as well as a portion of said second electrochemically active material.

25 36. A device according to any one of claims 31-35, wherein said substrate is made of paper or plastic or a combination thereof.

30 37. A device according to any one of claims 31-36, wherein said electrochemically active material comprises an electrically conductive polymer.

38. A device according to claim 37, wherein said electrically conductive polymer is electrochromic.

39. A device according to any one of claims 31-37, wherein said device is a transistor.

40. A device according to any one of claims 31-39 further comprising an
5 encapsulation covering the electrolyte composition.

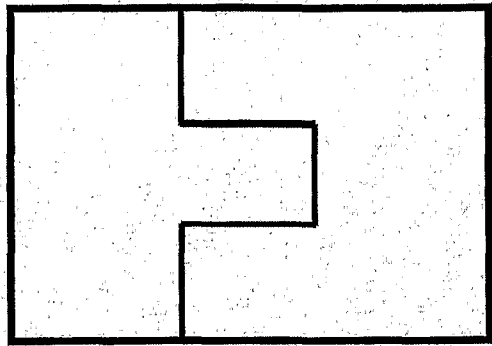

Fig. 1

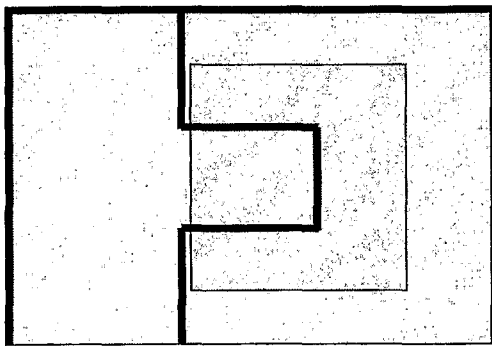

Fig. 2

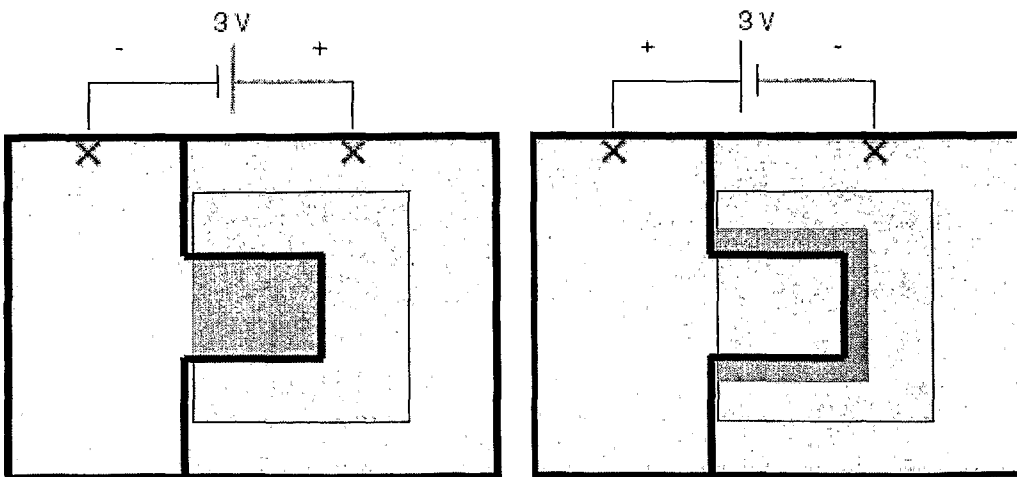

Fig. 3

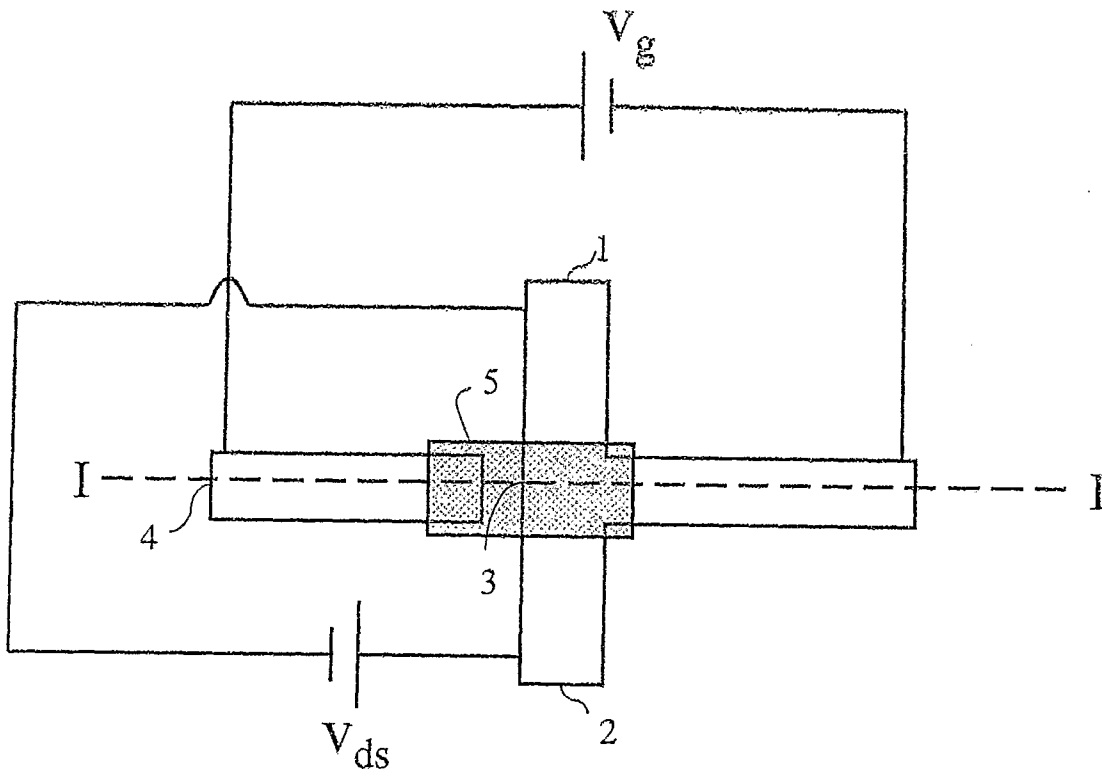

FIGURE 4A

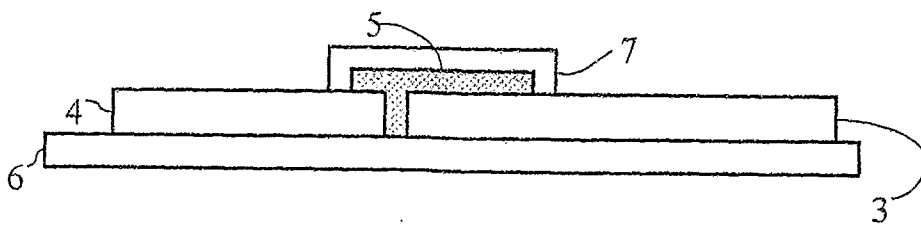
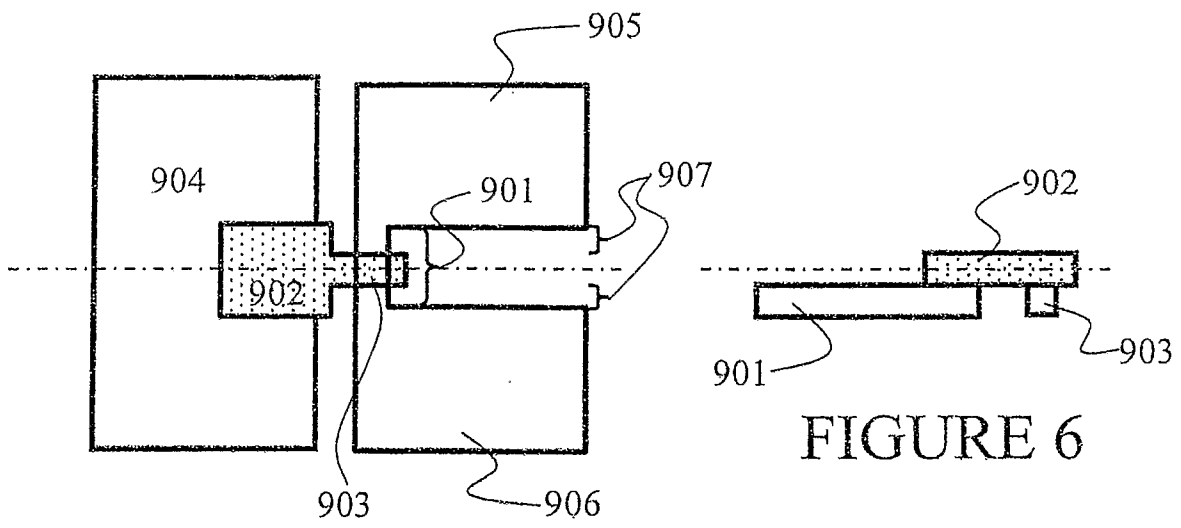
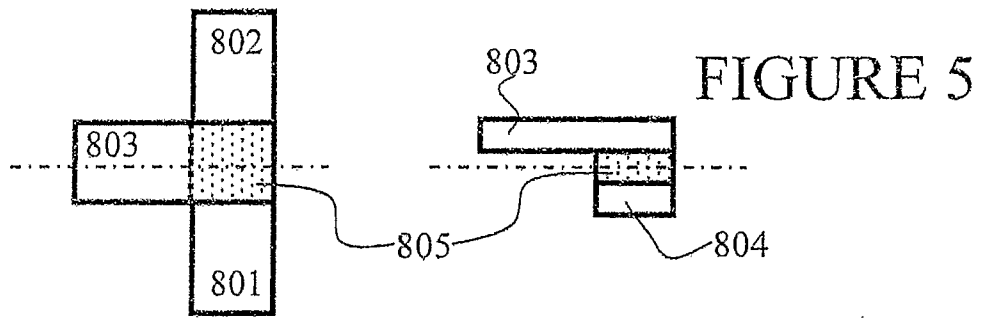

FIGURE 4B



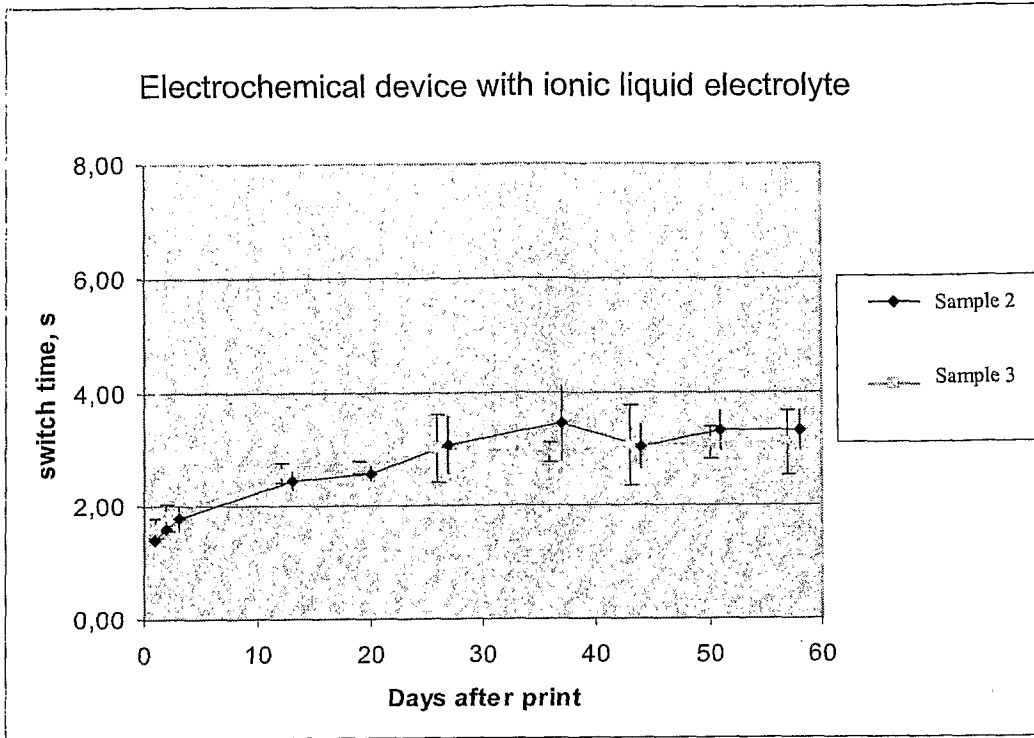

Figure 7a

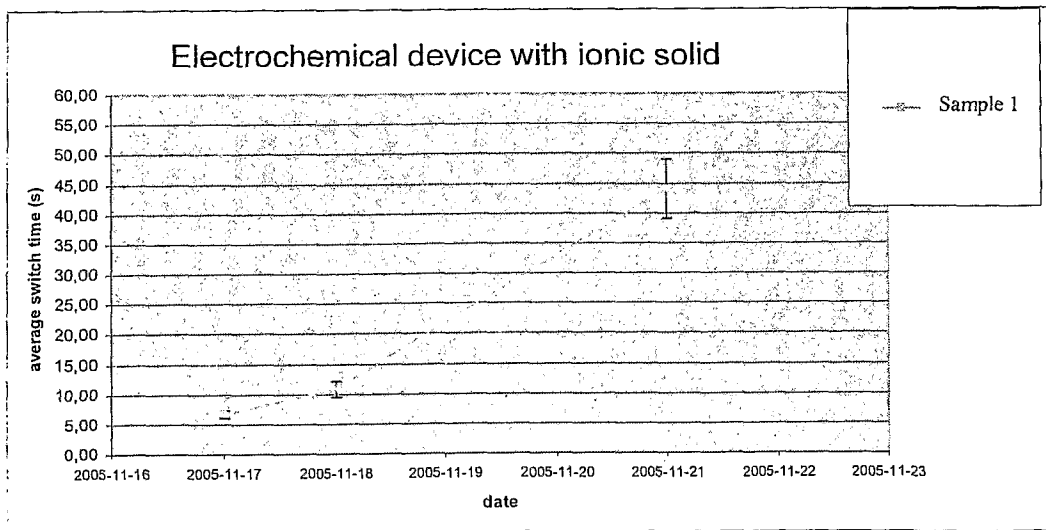

Figure 7b

INTERNATIONAL SEARCH REPORT

International application No
PCT/GB2007/002897

A. CLASSIFICATION OF SUBJECT MATTER
INV. G02F1/15 H01B1/12

According to International Patent Classification (IPC) or to both national classification and IPC

B. FIELDS SEARCHED

Minimum documentation searched (classification system followed by classification symbols)
G02F H01B

Documentation searched other than minimum documentation to the extent that such documents are included in the fields searched

Electronic data base consulted during the international search (name of data base and, where practical, search terms used)

EPO-Internal, WPI Data, INSPEC

C. DOCUMENTS CONSIDERED TO BE RELEVANT

Category*	Citation of document, with indication, where appropriate, of the relevant passages	Relevant to claim No.
X	WO 93/04507 A (BRITISH TECH GROUP [GB]) 4 March 1993 (1993-03-04)	1
Y	page 2 - page 4; claims 1-18; examples 1-6	2-40
X	US 6 214 251 B1 (WU HEW-DER [TW] ET AL) 10 April 2001 (2001-04-10)	1
Y	columns 8-12; claims 1-59	1-40
Y	DE 44 31 773 A1 (SKC LTD [KR]) 9 March 1995 (1995-03-09)	1-40
	page 2, line 41 - page 3, line 64; claims 1-6; examples 1-5	

Further documents are listed in the continuation of Box C.

See patent family annex.

* Special categories of cited documents :

- *A* document defining the general state of the art which is not considered to be of particular relevance
- *E* earlier document but published on or after the international filing date
- *L* document which may throw doubts on priority claim(s) or which is cited to establish the publication date of another citation or other special reason (as specified)
- *O* document referring to an oral disclosure, use, exhibition or other means
- *P* document published prior to the international filing date but later than the priority date claimed

- *T* later document published after the international filing date or priority date and not in conflict with the application but cited to understand the principle or theory underlying the invention
- *X* document of particular relevance; the claimed invention cannot be considered novel or cannot be considered to involve an inventive step when the document is taken alone
- *Y* document of particular relevance; the claimed invention cannot be considered to involve an inventive step when the document is combined with one or more other such documents, such combination being obvious to a person skilled in the art.
- * & * document member of the same patent family

Date of the actual completion of the international search

Date of mailing of the international search report

25 January 2008

01/02/2008

Name and mailing address of the ISA/

European Patent Office, P.B. 5818 Patentlaan 2
NL - 2280 HV Rijswijk
Tel. (+31-70) 340-2040, Tx. 31 651 epo nl,
Fax: (+31-70) 340-3016

Authorized officer

Wengeler, Heinz

INTERNATIONAL SEARCH REPORT

Information on patent family members

International application No

PCT/GB2007/002897

Patent document cited in search report		Publication date		Patent family member(s)	Publication date
WO 9304507	A	04-03-1993	DE	69227633 D1	24-12-1998
			DE	69227633 T2	22-04-1999
			EP	0599924 A1	08-06-1994
			JP	7500941 T	26-01-1995
			US	5581394 A	03-12-1996
<hr/>					
US 6214251	B1	10-04-2001	NONE		
<hr/>					
DE 4431773	A1	09-03-1995	JP	7242717 A	19-09-1995
<hr/>					