

Jan. 5, 1971

W. W. MONROE ET AL

3,551,931

HYDRAULIC MOTOR DRIVEN TOOTHBRUSH

Filed Feb. 28, 1969

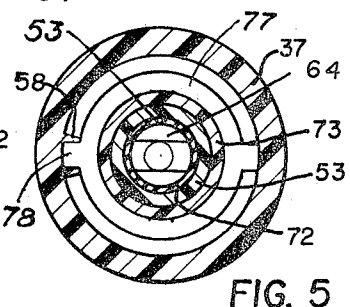
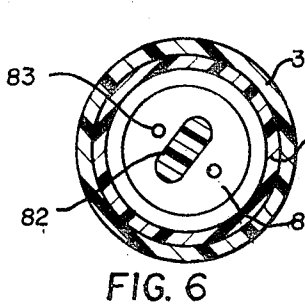
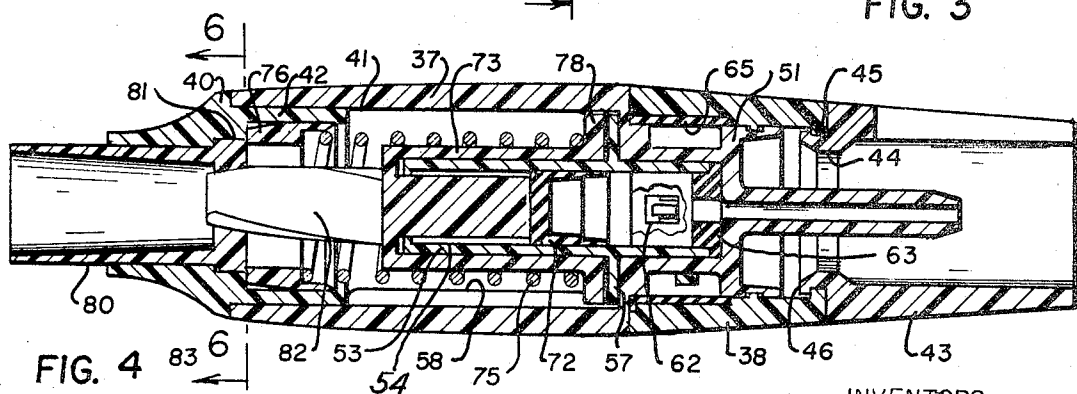
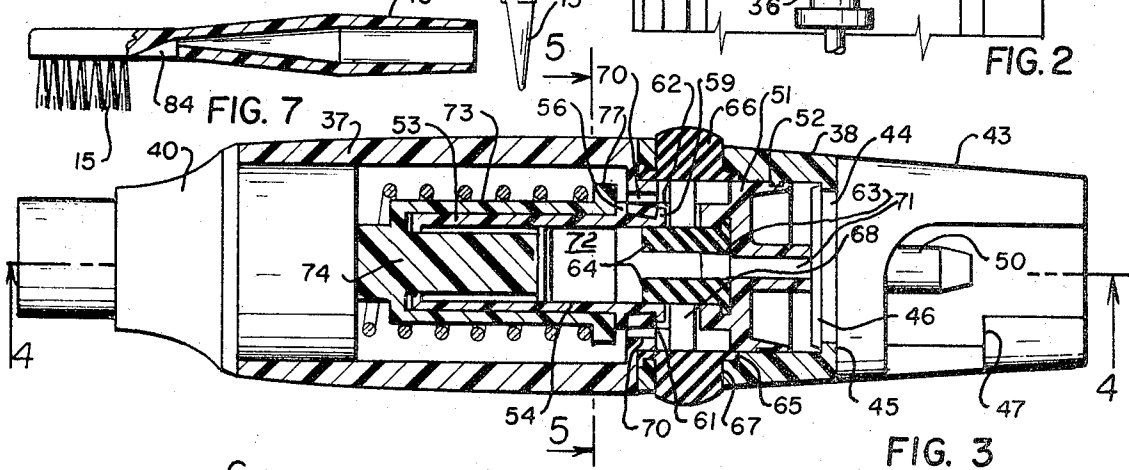
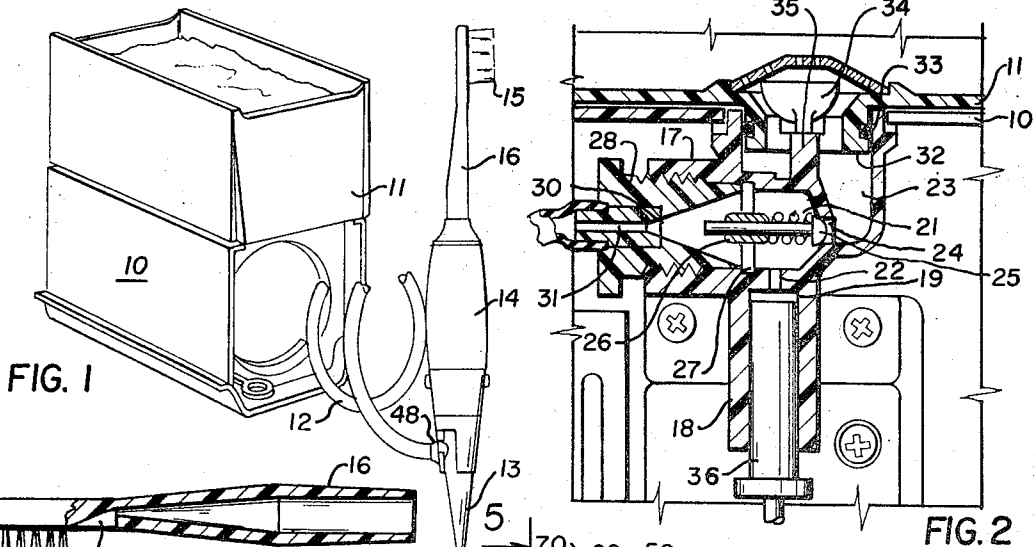

INVENTORS
 Wayne W. Monroe
 Siegmund Deines
 Homer A. Jeffers, Jr.
 John M. Trenary
 BY *McBrew & Edwards*
 ATTORNEYS

1

2

3,551,931

HYDRAULIC MOTOR DRIVEN TOOTHBRUSH

Wayne W. Monroe, Sigmund Deines, Homer A. Jeffers, Jr., and John M. Trenary, Fort Collins, Colo., assignors to Aqua Tec Corporation, Fort Collins, Colo., a corporation of California

Filed Feb. 28, 1969, Ser. No. 803,392

Int. Cl. A46b 13/06; A47k 7/04

U.S. Cl. 15—22

4 Claims

ABSTRACT OF THE DISCLOSURE

A toothbrush energized by an intermittent liquid pulse stream comprises a handle in which a hydraulic motor of the expansible chamber type is mounted and connected to drive the toothbrush with back and forth movement. The reciprocating movement of the motor is converted to oscillating movement of the brush by a helical post driven by the motor and slidably engaging a sleeve rotatably mounted in the handle and to which the brush is attached. The energizing pulse stream is connected in direct communication with the expansible chamber to drive the motor.

This invention relates to motor driven toothbrushes and particularly to a toothbrush of the type driven by a reciprocating hydraulic motor energized by an intermittent pulse stream and including an improved mechanism for converting the reciprocating movement of the motor to oscillating movement of the brush.

The present invention is an improvement on the motor driven toothbrush disclosed in a copending application of John W. Mattingly, Ser. No. 697,774, filed Jan. 15, 1968 and assigned to the same assignee as the present application. As disclosed in that application, both reciprocating or linear and oscillating or rotary back and forth movements of a toothbrush may be produced by a reciprocating motor energized by a stream of intermittent liquid pulses. When converting the reciprocating movement of the motor to oscillating movement of the brush it is desirable that the conversion be effected with minimum friction and with the driving parts effectively balanced about the central axis of the motor assembly. Accordingly, it is an object of the present invention to provide a motor driven toothbrush including an improved arrangement for converting reciprocating movement of the motor to oscillating motion of the brush.

It is another object of this invention to provide an improved hydraulic motor driven toothbrush of the oscillating brush type.

Briefly, in carrying out the objects of this invention, in one embodiment thereof, a toothbrush assembly is provided which comprises an elongated generally cylindrical handle having a cylinder block with a reciprocable piston mounted along the central axis of the assembly. A motion transmitting member is slidably mounted on the cylinder block and has a projection extending into the cylinder for engagement with the piston; the member is biased toward the piston to urge the piston toward its minimum volume position. A brush mounting sleeve is rotatably mounted adjacent the end of the handle and is of a configuration to receive a hollow shaft of a toothbrush. When

a supply of intermittent liquid pulses is provided at the inlet of the toothbrush a piston reciprocates in the cylinder and drives the transmitting member forward and back in the handle. In order to convert the reciprocating movement of the transmitting member to rotative movement of the brush mounting sleeve a helical post is secured to the motion transmitting member and extends toward the sleeve in longitudinal alinement therewith. The sleeve is provided with an opening of a configuration to receive the end of the post and upon reciprocation of the slidable member the post moves in and out of the sleeve and produces back and forth rotary movement thereof.

The features of novelty which characterize this invention are pointed out with particularity in the claims annexed to and forming a part of this specification. The invention itself, however, both as to its organization and method of operation together with further objects and advantages thereof will best be understood upon reference to the accompanying drawing in which;

FIG. 1 is a perspective view of an oral hygiene appliance and a toothbrush embodying the invention connected to be driven thereby;

FIG. 2 is an enlarged sectional view of the liquid pump employed in the appliance of FIG. 1;

FIG. 3 is an enlarged view partly in section of the toothbrush driving assembly of FIG. 1;

FIG. 4 is an enlarged view partly in section similar to FIG. 3 taken along the line 4—4 of FIG. 3;

FIG. 5 is a sectional elevation view taken along the line 5—5 of FIG. 3;

FIG. 6 is a sectional elevation view taken along the line 6—6 of FIG. 4; and

FIG. 7 is an enlarged view of the toothbrush element of FIG. 1.

Referring now to the drawing, in FIG. 1 an oral hygiene appliance 10 is illustrated as having a detachable reservoir 11 shown in position to supply water to the appliance. The appliance is actuated by an electric motor, not shown, which drives a reciprocating pump to produce an intermittent stream comprising pressure pulses of water separated by rest periods. This stream is supplied through a conduit 12 to a fixture 13 which has been shown connected to supply the stream to a toothbrush assembly 14 embodying the present invention. The assembly 14 includes a brush having bristles 15 and a shaft 16 connected to the driving mechanism of the assembly 14 so that it is moved with a back and forth rotary or oscillating action by the operation of a hydraulic motor in the body of the assembly.

The pump employed in the appliance 10 is illustrated in FIG. 2 which is a sectional view showing the reservoir 11 in position on top of the unit 10 directly above a pump body indicated at 17. The body 17 is formed to provide a cylinder block 18 within which there is formed an upright cylinder 19; immediately above the cylinder there is a pump chamber 21 connected to the cylinder 19 by a port 22. Water for the pump is supplied from an inlet chamber 23 of upright cylindrical configuration and is admitted to the chamber 21 through an inlet port 24. The inlet port is controlled by a spring pressed valve 25 which is mounted in a spider comprising a hub 26 and a ring 27 mounted centrally of the chamber 21; the ring

is locked in position by a threaded fitting 28 and has a cone shaped passage 30 formed therein which terminates in the outlet passage 31 of the pump. In order to supply water to the inlet chamber 23 the bottom of the reservoir 11 is formed with a downwardly extending boss 32 which is sealed to the walls of the chamber 23 by an O-ring 33. The reservoir is provided with an outlet valve 34 which is biased by gravity to its closed position; when the reservoir is placed in position on the unit the valve is lifted by engagement with a fixed post 35, as shown, so that the passage from the reservoir to the chamber 23 is open.

During the operation of the pump the piston, indicated at 36, is reciprocated in the cylinder 19 and draws water from the reservoir and chamber 23 through the port 24 to the chamber 21 and thence into the cylinder through the port 22. When the direction of the piston is reversed water is discharged from the cylinder 19 into the chamber 21 and thence out through the outlet 31. Because of the initial characteristics of the flow of water from the chamber 21 through the conduit 12 there being no discharge valve there is a tendency for water to continue to flow after the piston has reached its uppermost position and started to return; thus more water is discharged from the pump than the amount displaced by the piston. This type of flow has proved advantageous for use in appliances such as the appliance 10. The stream produced by this pump may be utilized to drive the toothbrush 14 in a manner which will be apparent from the following description. The discharge pressure of the stream may be controlled by an adjustable bypass (not shown) connecting the chamber 21 and the inlet chamber 23 so that if desired a portion of the water discharged from the cylinder 19 may be returned to the intake. This pump assembly and bypass control is essentially the same as that disclosed in United States Letters Patent No. 3,393,673 issued July 7, 1968 and assigned to the same assignee as the present application.

The configuration of the toothbrush assembly 14 as shown in FIGS. 3 through 6 is generally cylindrical and tapering slightly toward each end. The assembly includes a main housing 37 to which a sleeve 38 is attached at the right end and a cap 40 at the left end. The housing 37 has a cylindrical internal chamber 41 and the cap 40 is provided with a sleeve 42 which fits closely within the walls of the chamber 41 and is securely attached to the housing by cementing or welding. A retainer 43 is rotatably attached to the right end of the sleeve 38 and for this purpose has a boss or extension 44 which is pressed into an opening formed by an inturned flange 45 on the sleeve 38 and has an outwardly extending flange 46 which is pressed through the opening and expands to hold the retainer 43 in place on the sleeve. The components of the assembly 14 comprising the parts 37, 38, 40 and 43 are constructed of suitable synthetic plastic materials such as acrylonitrile-butadiene styrene polymers for parts 37 and 40 and acetal homopolymers for parts 38 and 43.

The configuration of the retainer 43 includes a bayonet slot 47 which is provided to engage a tube connecting boss 48 on the fixture 13 and retain the fixture in position with its outlet in engagement with a nipple 50 formed as a central axial extension of a reduced cylindrical portion 51 of the housing 37. The portion 51 fits within the sleeve 38, and has an annular groove which, when the sleeve and housing are pressed together, engages a complementary inwardly extending flange 52 on the sleeve 38, thereby holding the sleeve on the housing. A longitudinal cylinder block 53 having a central longitudinal cylinder bore 54 is secured within the reduced portion 51 of the housing and extends concentrically about the longitudinal axis of the assembly 14. The cylinder block 53 has an outwardly extending flange 56 which is seated against portion 51 and determines the longitudinal position of the block. The flange 56 has two lugs or ears 57

diametrically opposite one another as shown in FIG. 4 and the lower one of these engages a guideway formed by two longitudinal ribs 58 extending inwardly from the internal wall of the housing 37. The two ribs 58 determine the position of the cylinder block 53 about the longitudinal axis and brings two small upstanding lugs 59 on the block into position so that they may be staked by two diametrically opposite portions 61 of the housing adjacent openings 62 therein and together with the flange 56 prevent longitudinal movement of the cylinder block 53 in either direction. When the cylinder block is positioned in this manner, it locks a flexible gasket and valve member 63 securely in position against the right inside wall of the housing. The member 63 has two flexible extensions 64 which cover openings in the cylinder 53 which are in register with the openings 62 in the extension 51. A rubber sealing ring 65 is mounted between the sleeve 38 and the extension 51 and is provided with integral buttons 66 which extend through diametrically opposite openings 67 in the sleeve 38. Valve stems 68 are positioned in the openings in the housing portion 51 and cylinder block 53 and are in engagement with the buttons 66 and the valve 64 at their respective ends. When the buttons 66 or either of them is pressed, the corresponding valve members 64 are pressed inwardly and provide a passage from within the cylinder block 53 through the openings in the block and the housing to passages 70 providing communication with the cylindrical chamber within the housing 37, and about the main body portion of the cylinder block 53. When this passage is opened water flowing from the fixture 14 passes through a central passage 71 in the nipple 50 and flows into the main chamber within the housing 37.

A free floating piston 72 is arranged to reciprocate a cylindrical member 73 which is slidably mounted on the external wall of the cylinder block 53 and is provided with an internally extending portion 74 which engages the piston 72 when it moves to the left as viewed in FIGS. 2, 3 and 4. The member 73 is biased toward the right by a compression spring 75 which engages a retainer ring 76 mounted within the sleeve 42 of the cap 40 and a flange 77 on the member 73, thereby pressing the member 73 to the right against the flange 56 of the cylinder block which bears against the internal portion 51 of the housing. The flange 77 is provided with diametrically opposite extensions 78, the lower one of which engages the guideway 58 and prevents rotation of the member 73.

When the stream of liquid pulses is admitted to the cylinder through the passage 71, the piston 72 moves to the left on each pressure pulse and returns when the pressure subsides, thereby reciprocating the member 73. The member 73 constitutes a converter for changing the reciprocating movement thereof to rotary back and forth movement or oscillation of the toothbrush 15. This converting action is effected by providing a sleeve 80 having an internal retaining flange 81 within a cylindrical passage in the cap 40 and providing a helical post 82 as an integral part of the member 73 and which at its outer end as shown in FIGS. 4 and 6 engages a complementary opening in the inside end of the sleeve 80. The sleeve 80 is held in position against longitudinal movement by the shoulder in the cap 40 engaged by the flange 81 and by the retaining ring 76. Thus, as the post 82 is reciprocated, this motion is converted to oscillatory rotary motion of the sleeve 80 and the shaft 16 of the toothbrush when inserted in the sleeve 80 and held by the taper fit of these parts is oscillated.

When the toothbrush is to be used, the shaft 16 is inserted in the sleeve 80 and held by a taper fit, the motor of the unit 10 is then started to reciprocate the piston 36 of the pump and the buttons 66 are pressed inwardly so that the fluid discharged by the fitting 13 will pass through the passage 71 and the passage 70 into the chamber surrounding the converter member 73. This liquid then passes through openings 83 formed in the end

5

wall of the sleeve 80 laterally of the opening engaging the post 82 and the fluid thus passes through the shaft 16 to a discharge opening adjacent the brush 15, as shown in FIG. 7, the passage through the toothbrush and terminating in an opening 84 adjacent the bristles 15. By providing this open passage for water and any air which may be discharged through the fixture 13, the air may be purged from the interior of the toothbrush assembly and thereafter when the buttons 66 are released, the piston 72 is reciprocated by the pulsed action of the water stream. Reciprocation of the piston 72 thereby produces the oscillating action of the sleeve 80 and the oscillation of the brush bristles 15. Water may be supplied adjacent the bristles at the option of the operator at any time by pressing the buttons 66. The internal elements of the assembly including the cylinder block 53, the converter 73 and its helical post 82 and the sleeve 80 are all constructed of a synthetic plastic material such as acetal homopolymers or acetal polymers impregnated with tetrafluoroethylene (TFE). The operation of these elements in the water supplied to the unit has been found highly effective, the post 82 providing a simple, effective and rugged element for converting the reciprocating movement of the piston 72 to oscillation of the toothbrush. Lubrication of the plastic parts is effectively maintained by the water within the unit and smooth and positive action of the toothbrush results.

We claim:

1. A motor driven toothbrush for use with an oral hygiene appliance of the type having an output fixture for delivering a stream of intermittent liquid pressure pulses comprising a housing and a toothbrush mounted thereon, a hydraulic motor of the expansible chamber type movable between minimum and maximum volume positions mounted in said housing, the mounting for said toothbrush comprising an attaching element rotatably mounted on said housing, a connecting member slidably and non-rotatably mounted within said housing, means for utilizing said motor for reciprocating said connecting member, said utilizing means including means for biasing said member and said motor toward the minimum volume position of said motor, a helical post on said member positioned for reciprocating movement with respect to said attaching element, means on said element for engaging said post and imparting oscillating movement to said

6

element upon reciprocation of said post, and means for connecting the discharge fitting of an intermittent liquid pressure appliance to said housing with the output thereof in closed communication with said expansible chamber motor.

2. A motor driven toothbrush as set forth in claim 1 wherein said motor comprises a cylinder having its axis arranged longitudinally of said handle in alignment with said element and a free floating piston in said cylinder, said slidable member being mounted for sliding movement with respect to said cylinder and having a portion extending into said cylinder for engagement with said piston.

3. A motor driven toothbrush as set forth in claim 1 wherein said motor comprises a cylinder block rigidly secured within said handle and having a cylinder therein with its axis arranged longitudinally of said handle in alignment with said element and a free floating piston in said cylinder, said slidable member being mounted on the outer wall of said cylinder block in sliding engagement therewith for reciprocating thereon and having a portion extending into said cylinder for engagement with said piston.

4. A motor driven toothbrush as set forth in claim 1 wherein said attaching element comprises a sleeve rotatably mounted in said handle for holding a toothbrush shaft therein and wherein said means for engaging said post comprises a transverse wall on said sleeve having an opening of a configuration to receive said post and having a further opening for affording the passage of water there-through, and means for bypassing liquid around said motor for discharge into the interior of said handle and thence outwardly through said further opening in said wall.

References Cited

UNITED STATES PATENTS

3,093,900	6/1963	Myers	-----	15-22UX
3,484,885	12/1969	Deines et al.	-----	15-22

EDWARD L. ROBERTS, Primary Examiner

U.S. Cl. X.R.

60-545; 74-89.15; 128-62