

G. R. CLIFFORD.
 HYDROPLANE VESSEL.
 APPLICATION FILED JULY 8, 1910.

Patented July 18, 1911.

3 SHEETS—SHEET 1.

998,278.

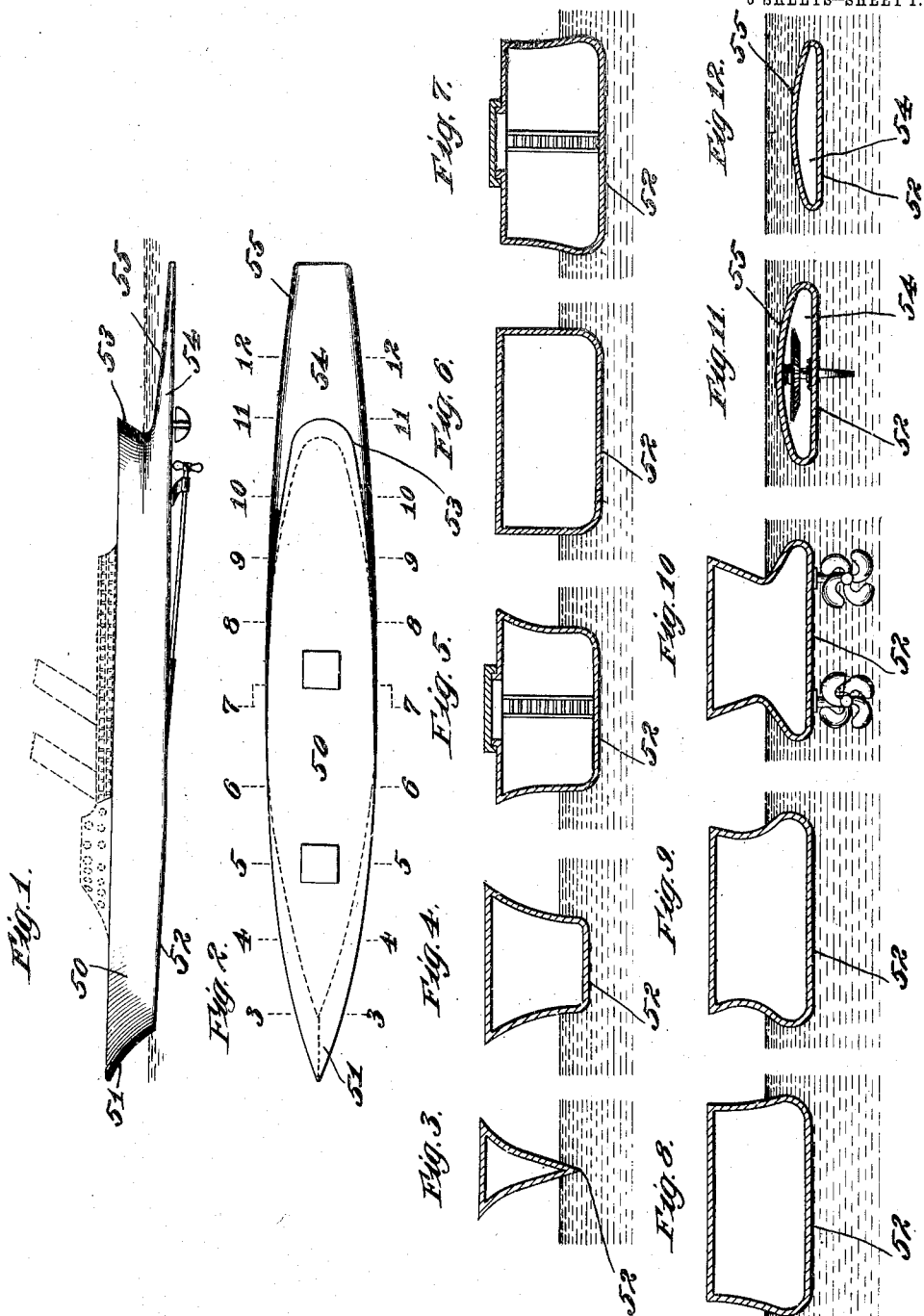

Witnesses:

Wm. D. Perry
John Wilson

Inventor
 George Bonstrom Clifford

By *Gilson & Gilson*
 Attys.

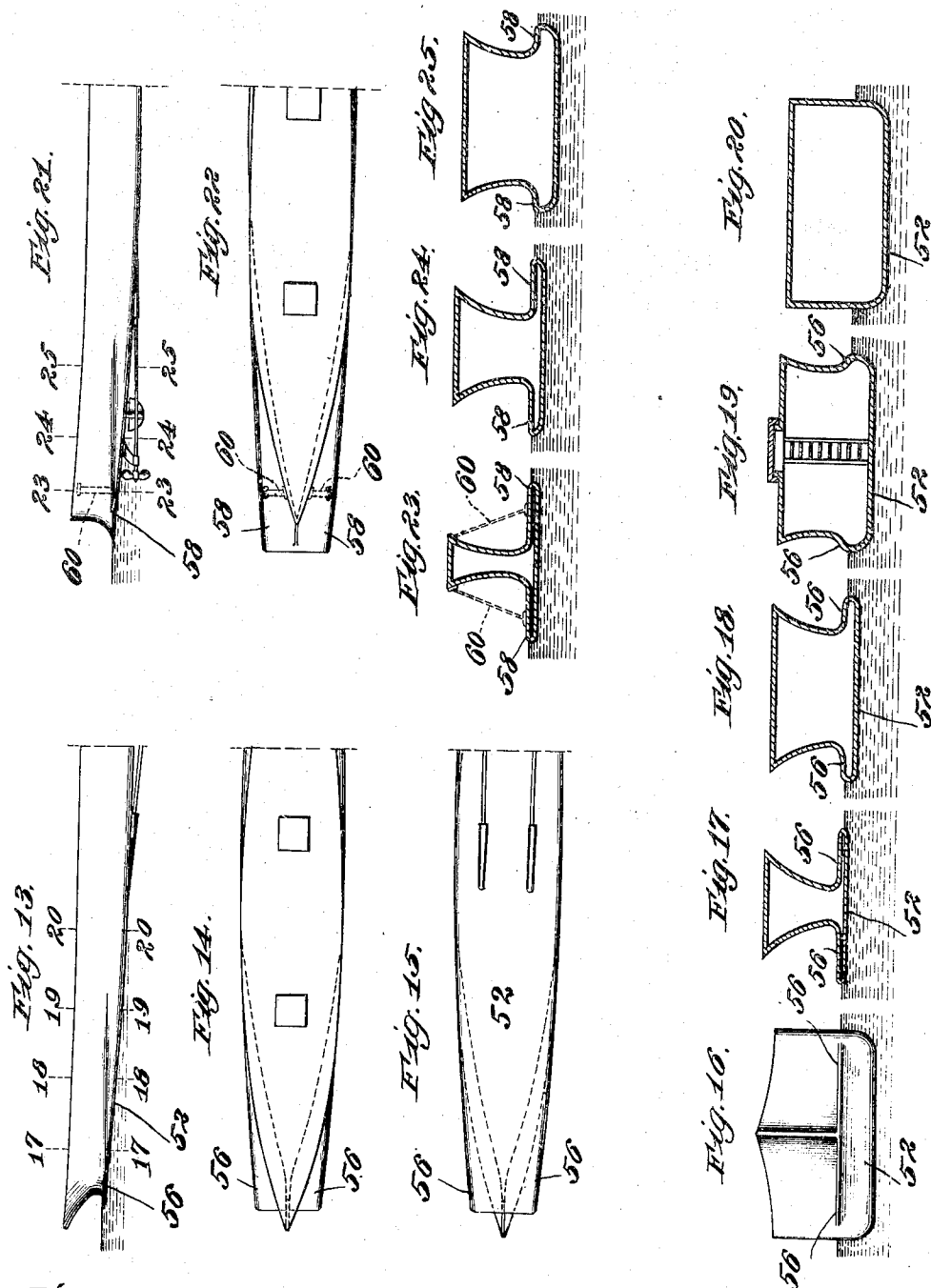

Witnesses:

Wm. D. Terry
Samuel Nelson

Inventor

George Rorstrom Clifford,

By *Gilbert & Gilbert*
 Attys

998,278.

G. R. CLIFFORD.
HYDROPLANE VESSEL.
APPLICATION FILED JULY 8, 1910.

Patented July 18, 1911.

3 SHEETS—SHEET 3.

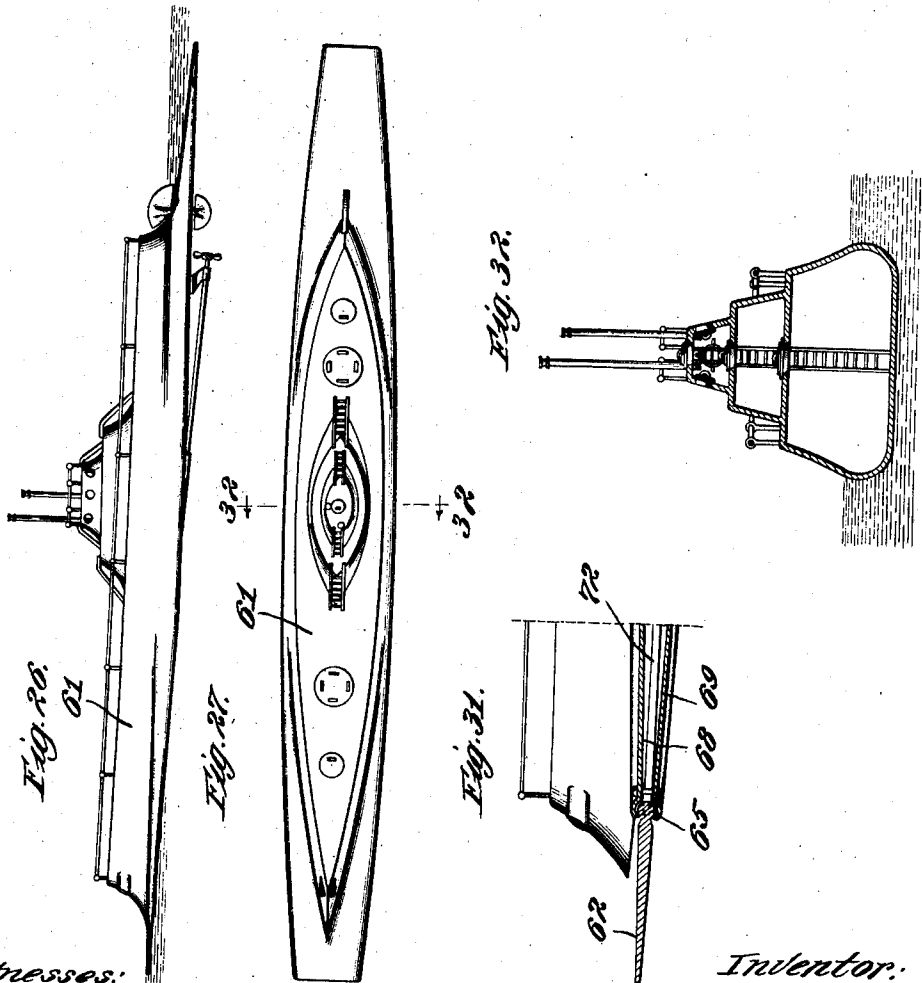
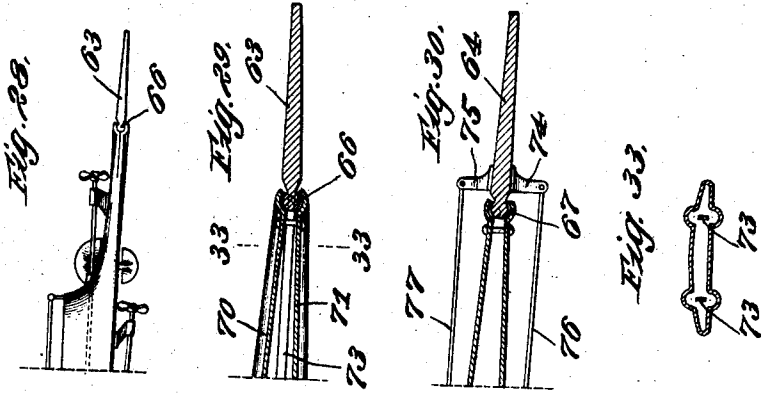

Witnesses:
Wm. P. Perry
Edw. M. Nelson

Inventor:
George Rowstrom Clifford,
 BY *Gilbert Gillson* Atty.

UNITED STATES PATENT OFFICE.

GEORGE RONSTROM CLIFFORD, OF CHICAGO, ILLINOIS.

HYDROPLANE VESSEL.

998,278.

Specification of Letters Patent. Patented July 18, 1911.

Application filed July 8, 1910. Serial No. 571,076.

To all whom it may concern:

Be it known that I, GEORGE RONSTROM CLIFFORD, a subject of the King of England, and a resident of Chicago, county of Cook, and State of Illinois, have invented certain new and useful Improvements in Hydroplane Vessels, of which the following is a specification, and which are illustrated in the accompanying drawings, forming a part thereof.

This invention relates to vessels constructed with downwardly and rearwardly inclined bottoms for the purpose of securing a lifting action when advancing, which construction has caused the term hydroplane to be applied to vessels of this type.

The objects of the present invention are to generally improve the vessel, and particularly to so construct it as to secure an increased lifting action at the prow while reducing the head resistance to the minimum; to provide, in conjunction with these advantages, means for deflecting the bow wave and utilizing it for further lifting action; and by improving the contour of the stern extension of the vessel, thereby reducing the so-called water drag. These objects are attained in the vessel forming the subject of this application, and are fully hereinafter described and illustrated in the accompanying drawings, in which—

Figure 1 is a side elevation of the vessel; Fig. 2 is a plan view thereof; Figs. 3 to 12 are transverse sections taken, respectively, on the lines 3—3, 4—4, 5—5, 6—6, 7—7, 8—8, 9—9, 10—10, 11—11 and 12—12 of Fig. 2; Fig. 13 is a detail side elevation of the forward part of the vessel showing a modified form of construction; Figs. 14 and 15 are, respectively, detail plan and bottom plan views of the vessel shown in Fig. 13; Fig. 16 is a front elevation of the same vessel; Figs. 17 to 20 are cross-sections, respectively, on the lines 17—17, 18—18, 19—19 and 20—20 of Fig. 13; Fig. 21 is a detail side elevation and Fig. 22 a detail plan view of the forward part of the vessel, showing a further modification; Figs. 23, 24 and 25 are cross-sectional views, respectively, on the lines 23—23, 24—24 and 25—25 of Fig. 21; Figs. 26 and 27 are, respectively, a detail side elevation and a plan view of a submergible vessel; Fig. 28 is a detail side elevation of the vessel shown in Figs. 26 and 27, showing a modified form of construction; Figs. 29 and 30 are detail vertical sections

of the stern extensions of the vessel shown in Fig. 28, showing two slightly different forms; Fig. 31 is a detail side elevation, partly in section, of the forward end of a vessel, such as that shown in Figs. 26 and 27, with a modification; and Figs. 32 and 33 are cross-sections, respectively, on the line 32—32 of Fig. 27 and 33—33 of Fig. 29.

In the drawings a mere outline of the vessel's hull is shown.

Referring to Figs. 1 to 12, the vessel 50 is shown as having a receding pointed prow 51, the upper portion of which broadens rapidly from its foremost point rearwardly, the prow, therefore, taking a V shape, as shown in Fig. 3, the side walls being preferably concave for the purpose of better deflecting the bow wave. From the base of the prow the vessel's bottom 52 is flat but inclined downwardly, and, as shown in Figs. 4, 5, 6 and 7, widens backwardly to approximately midship. From this point to the stern the vessel's bottom continues flat and downwardly inclined, but is narrowed gradually, as shown in Figs. 8 to 12.

The stern 53 of the vessel preferably flares upwardly, as shown in Fig. 1, for the purpose of increasing the carrying capacity. The hydroplane of the vessel is continued backwardly from the stern as an extension 54, which is normally below water. The upper portion of this stern extension is rounded, as shown at 55, to permit the easy flow of water thereover.

In order to increase the lifting surface at the prow of the vessel, the bottom 52 may be extended laterally at its forward end, as shown at 56, 56, in Figs. 13 to 19. In Figs. 13, 14 and 15 the vessel is shown with a receding prow, and in Figs. 21 and 22 with a vertical prow. In these instances the extensions of the bottom may project to and beyond the prow. These extensions gradually diminish, relatively as to the bottom of the vessel backwardly from the prow thereof, as shown in Figs. 16 to 19, and may entirely disappear, as shown in Fig. 20. The rear part, not shown, of the vessel as illustrated in Figs. 13 to 25, inclusive, is substantially the same as that of the vessel illustrated in Figs. 1 to 12, inclusive.

In Figs. 26 to 33 the invention is shown as applied to a submergible vessel 61, the forward and rearward extension for the bottom being of greater length relatively to the hull proper than in the preceding figures.

In Figs. 28, 29, 30, 31 and 33, further modifications of these forward and rearward extensions are shown at 62, 63 and 64. In these instances the bottom extensions are
5 shown as transversely hinged to the main bottom portion so as to be capable of adjustment to vary the inclination, serving in a sense as rudders for guiding the vessel up or down. The parts 62, 63 and 64 take the
10 form of blades, having at their inner ends rounded portions 65, 66, 67, constituting pivots secured between upper and lower plates 68, 69, or 70, 71, the ends of which are suitably curved to form a receiving
15 socket. In Figs. 29 and 31, the blades 62 and 63 are shown as controlled by levers 72, 73, which extend into the hull of the vessel and are actuated by any suitable mechanism (not shown).

20 In Fig. 30 the blade 64 is shown as provided with upwardly and downwardly projecting arms 74, 75, to which are attached pull rods 76, 77.

As seen from the various side elevations
25 on the accompanying drawings, the rearwardly and downwardly inclined hydroplane bottom surface of the vessel consists of two large planes in longitudinal continuous succession, which longitudinally form a
30 slight downward angle with each other; the forward plane having a slightly stronger inclination than the rear one. The purpose of thus having two bottom planes of different longitudinal inclination is to bring the
35 forward end of the hydroplane up near the water surface and increase its lifting action at speed in front, at a minimum increase of head resistance, and still maintain a desirable depth or displacement of vessel.

40 The bottom extensions, whether fixed or hinged, will, under speed, materially assist the vessel up on top of the water; and will distribute its weight over a sufficiently large area of the water to insure easy skimming
45 thereover, even at comparatively low speed. The forward extensions will to a great extent cut down and smother the detrimental bow wave, and utilize its force to lift the forward end of the vessel, thereby materially reducing the resistance of any remaining wave. They also serve to steady
50 the vessel when under speed, and to a large extent to counteract any tendency to roll.

If desired stays 60 may be provided to
55 strengthen the lateral bottom extensions 58, though ordinarily it will doubtless be found advisable to avoid the use of such stays, giving the frame of the bottom ample strength.

The bottom extensions, both laterally and
60 forward, not only increase the area of the inclined hydroplane surface and consequently the lifting power, but tend materially to steady the vessel in rough weather, while offering practically no resistance to
65 its advance through the water. They also

reduce the bow wave in volume, riding over much of the water which would otherwise be thrown up by the prow.

The tapering form of the stern extension contributes to the ease of movement of the
70 vessel through the water.

I claim as my invention—

1. A hydroplane vessel or boat with a rearwardly and downwardly inclined main bottom surface, constituting the hydroplane,
75 said bottom surface consisting of a plurality of large planes in longitudinal continuous succession, forming longitudinally a slight downward angle with each other; the forward plane having a somewhat stronger
80 inclination than the rear one, and having rearwardly and downwardly inclined lateral extensions extending beyond the sides of the hull.

2. A hydroplane vessel or boat substantially as shown, with a transversely level and flat rearwardly and downwardly inclined main bottom surface, constituting the hydroplane, said bottom surface consisting
90 of two large planes in longitudinal continuous succession which form a slight downward angle with each other; the forward plane commencing forward of the vessel's upper hull, and having for greater lifting
95 action a slightly stronger inclination than the rear plane; said forward plane and merged portion of hull, being laterally extended considerably beyond the sides of the vessel's upper hull, and forming longitudinally a wide and thin hydroplane wedge,
100 flatwise under the vessel's upper hull.

3. A hydroplane vessel or boat with a sharp bow and a rearwardly and downwardly inclined main bottom surface, constituting the hydroplane, said bottom surface
105 consisting of two or more large planes in longitudinal continuous succession and forming longitudinally a slight downward angle with each other; the forward plane commencing far forward of the stem of the
110 vessel's upper hull with a thin horizontal and transversal edge near the water surface, and having for greater lifting action a slightly stronger longitudinal inclination than the rear plane; said forward bottom plane and
115 lower portion of hull, from near the water line and downward, being for increase of hydroplane surface extended laterally far beyond the side walls of the vessel's upper hull, and forming vertically and longitudinally a long drawn, wide and thin hydroplane wedge, flatwise under the vessel's upper hull; said hydroplane wedge having for
120 minimum water grip or resistance in lifting action, its upper surface substantially flat and level.

4. A hydroplane vessel or boat substantially as shown with a transversely flat rearwardly and downwardly inclined main bottom surface, constituting the hydroplane,
130

said bottom surface consisting of two large planes in longitudinal continuous succession, which form a slight downward angle with each other; the forward plane commencing far forward of the vessel's upper hull, with a thin horizontal edge near the water surface, and having for greater lifting action a slightly stronger inclination than the rear plane; the vessel having its forward end portion in vertical cross section resembling an inverted capital letter T but of sharp entrance both ways, so as to divide the water vertically and laterally; the horizontal bar of the T representing the forward vertically and longitudinally wedge shaped end of the vessel's hydroplane bottom, and its lateral extensions or wings; said hydroplane wings increasing in vertical thickness rearwardly with the merged depth of the vessel, and having their upper surfaces substantially flat and level.

5. A hydroplane vessel or boat with a transversely level and flat rearwardly and downwardly inclined main bottom surface, constituting the hydroplane, said bottom surface consisting of two or more large planes in longitudinal continuous succession, which form a slight downward angle with each other; the forward plane commencing far forward of the stem of the vessel's upper hull with a thin, horizontal and transversal edge near the water surface, and having for greater lifting action under speed, a slightly stronger inclination than the rear plane; said bottom planes and lower portion of the vessel's hull, from near the water line at rest and downward, being for increase of hydroplane surface extended laterally, considerably beyond the side walls of the vessel's upper hull; the vessel having its forward end portion of sharp water entrance vertically and laterally; the upright stem or cutwater constituting the sharp forward end of the vessel's upper hull, the horizontal and transversal cutwater constituting the thin forward, vertically and longitudinally wedge-shaped end of the vessel's hydroplane bottom, and its lateral extensions or wings; the entire hydroplane bottom and its lateral

extensions tapering gradually in vertical thickness or depth, and also somewhat in width, toward both ends, substantially as shown on the accompanying patent drawings.

6. A hydroplane vessel or boat substantially as shown, having its bottom extended forwardly and rearwardly, far beyond the vessel's hull, with a vertical and also somewhat lateral taper toward each end; the end portions of said extensions being transversely hinged to the main bottom portion of the vessel, and levers extending into the hull of the vessel for vertically moving the hinged portion of the bottom extension.

7. A hydroplane vessel or boat with its entire main bottom surface rearwardly and downwardly inclined, and constituting the hydroplane, having the forward and rearward portions of its hull laterally contracted near its water line at rest, and having its commencement in vertical cross section shaped to the form of an inverted capital letter T, but of fine water entrance vertically and laterally; the horizontal bar of the T representing lateral bottom extensions or vertically and longitudinally wedge shaped hydroplane wings extending outward into the water, said wings having their upper surfaces near the water surface, and substantially flat and level.

8. A hydroplane vessel with its entire main bottom surface rearwardly and downwardly inclined and constituting the hydroplane, having the forward and rearward portions of its hull laterally contracted near its water line at rest and its commencement being shaped to the form of the capital letter T inverted, of fine water entrance vertically and laterally; the horizontal bar of the T representing lateral bottom extensions or longitudinally wedge-shaped hydroplane wings, extending outward into the water, in continuation of the vessel's bottom surface.

GEORGE RONSTROM CLIFFORD.

Witnesses:

LOUIS K. GILLSON,
E. M. KLATCHER.