

No. 640,890.

Patented Jan. 9, 1900.

J. W. EISENHUTH.
AIR AND GAS ENGINE.
(Application filed June 14, 1899.)

3 Sheets—Sheet 1.

(No Model.)

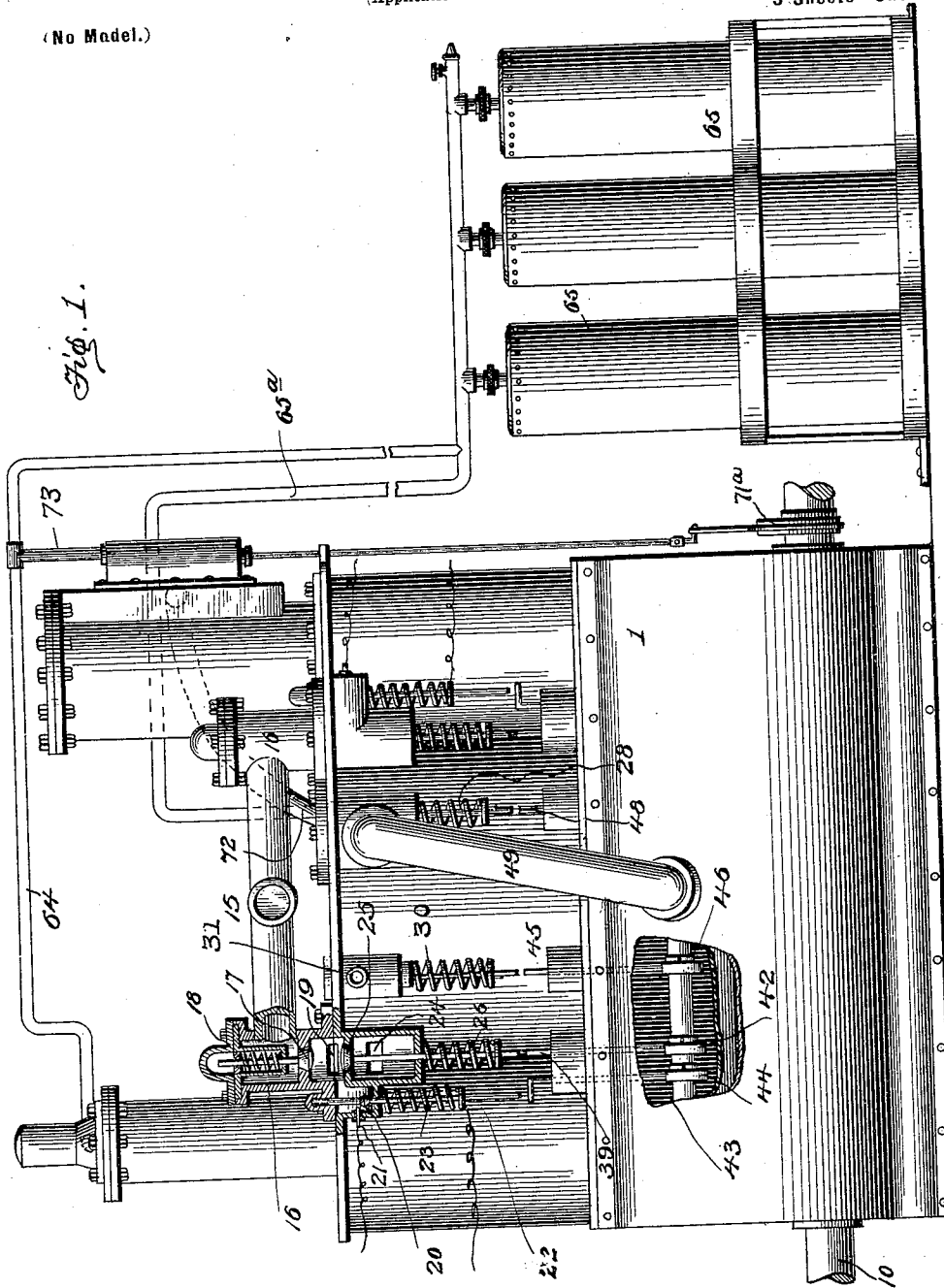

WITNESSES
Fenton & Belt
Allan St. Guss.

INVENTOR
John W. Eisenhuth
By Mason Fenwick & Co.
his Attorneys

No. 640,890.

Patented Jan. 9, 1900.

J. W. EISENHUTH.
AIR AND GAS ENGINE.
(Application filed June 14, 1899.)

3 Sheets—Sheet 2.

(No Model.)

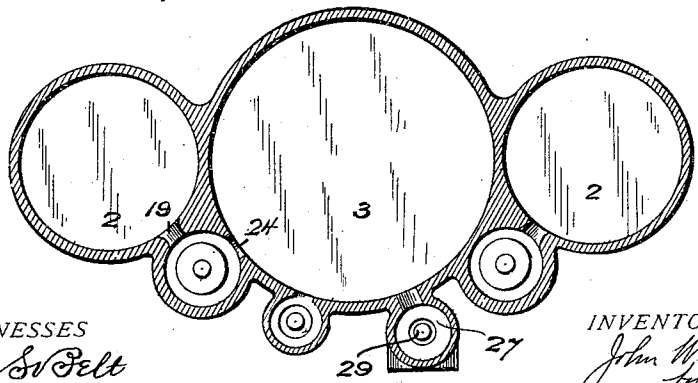
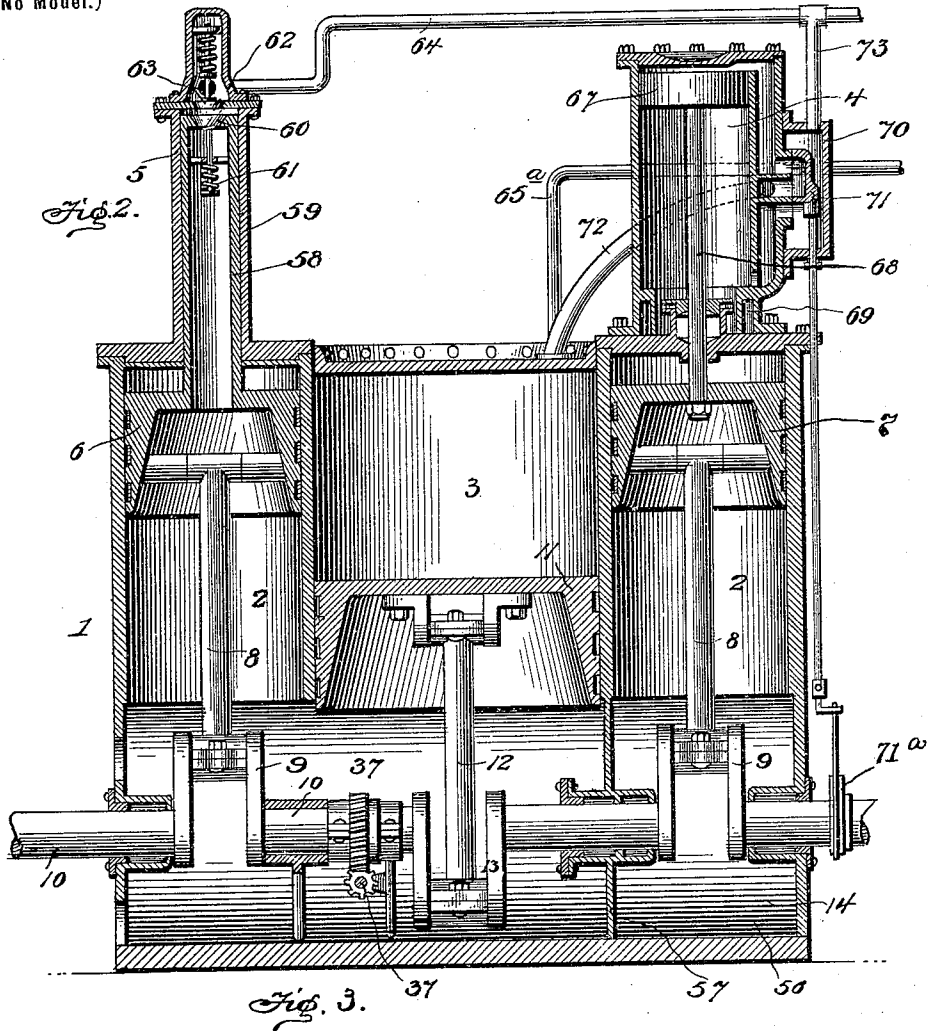

WITNESSES
Fenton S. Belt
Allan M. Fuss.

INVENTOR
John W. Eisenhuth
Maximilian K. Knecht
his Attorney

No. 640,890.

Patented Jan. 9, 1900.

J. W. EISENHUTH.
AIR AND GAS ENGINE.

(Application filed June 14, 1899.)

(No Model.)

3 Sheets—Sheet 3.

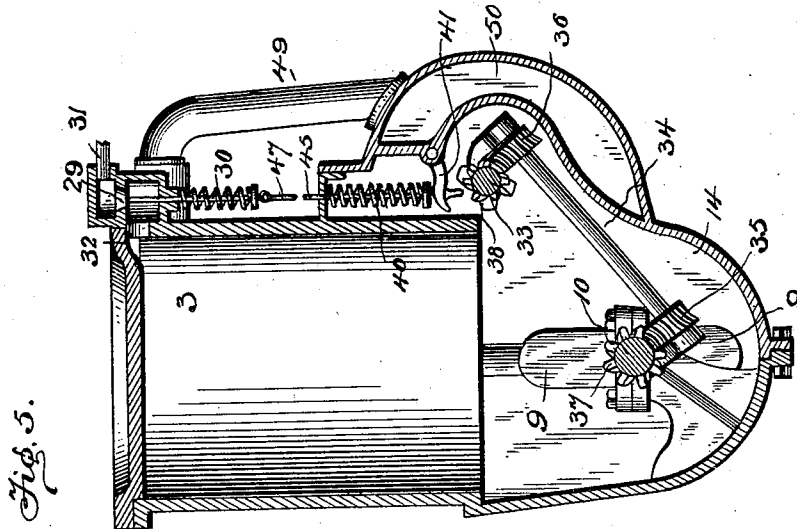

Fig. 5.

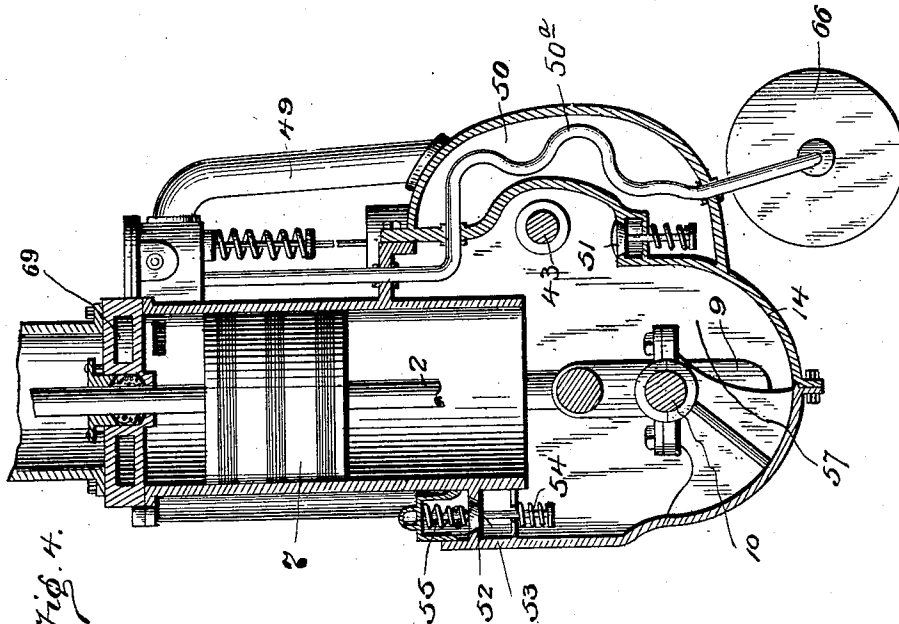

Fig. 4.

WITNESSES

Tenton S. Belt,
Allan H. Fuss.

INVENTOR

John W. Eisenhuth
by his Attorney
Mary J. Smith

UNITED STATES PATENT OFFICE.

JOHN W. EISENHUTH, OF NEW YORK, N. Y., ASSIGNOR TO MAMIE G. READ,
OF SAME PLACE.

AIR AND GAS ENGINE.

SPECIFICATION forming part of Letters Patent No. 640,890, dated January 9, 1900.

Application filed June 14, 1899. Serial No. 720,593. (No model.)

To all whom it may concern:

Be it known that I, JOHN W. EISENHUTH, a citizen of the United States, residing at New York, in the county of New York and State of New York, have invented certain new and useful Improvements in Air and Gas Engines; and I do hereby declare the following to be a full, clear, and exact description of the invention, such as will enable others skilled in the art to which it appertains to make and use the same.

My invention relates to improvements in air and gas engines, and more particularly to that class of engines which are adapted to be used as compound engines.

It consists in an engine having high-pressure cylinders and a lower-pressure cylinder, means for admitting an explosive mixture to the high-pressure cylinders, means for admitting the exhaust from the said high-pressure cylinders to the low-pressure cylinder, and means for introducing compressed air into the said low-pressure cylinder for assisting in the operation of the engine.

It also consists in an engine having high and low pressure cylinders, an air-cylinder arranged upon the end of one of the high-pressure cylinders, the piston of which is connected up with the piston of the high-pressure cylinder, an air-compressor mounted upon the end of the other high-pressure cylinder, means for storing the air compressed, and piping for leading the compressed air to the air-cylinder or the low-pressure cylinder, as may be desired.

It further consists in certain other novel constructions, combinations, and arrangements of parts, as will be hereinafter described and claimed.

In the accompanying drawings, Figure 1 represents a side elevation of an engine constructed in accordance with my invention. Fig. 2 represents a central vertical longitudinal section through the same. Fig. 3 represents a horizontal section through the cylinders of the said engine and the valve for controlling the admission of the expansive compound and air to the various cylinders. Fig. 4 represents a vertical transverse section through one of the high-pressure cylinders, and Fig. 5 represents a similar view through the low-pressure cylinder.

1 in the drawings represents a gas-engine, 2 2 high-pressure cylinders, and 3 a low-pressure cylinder.

4 indicates an air-cylinder, and 5 an air-compressor.

I find that by employing a low-pressure cylinder adapted to receive the exhaust from the high-pressure gas-engine cylinders a compound engine of considerable power can be produced. By this construction a considerable amount of power which would be wasted may be utilized and opportunity afforded for the use of compressed air in addition to the said exhaust for giving further power to the engine.

In carrying out the features of the invention I mount the high-pressure cylinders 2 2 at each end of a suitable casing, the low-pressure cylinder 3 being preferably interposed between the two. High-pressure pistons, as 6 7, are adapted to move in the cylinders 2 2 and are connected by means of pitmen 8 8 with the cranks 9 9 of the main power-shaft 10. The pitmen 8 are preferably pivotally secured to the heads 6 and 7, which are made hollow for this purpose. There would be no need for cross-heads in this construction, as the lower ends of the cylinders 2 2 are open. The low-pressure cylinder 3 is provided with a hollow piston 11, which is connected by means of a pitman 12 with a crank 13 on the main shaft 10. The pitman 12 is also pivotally connected to the piston 11 by a suitable bracket, as illustrated in Fig. 2 of the drawings. The piston-rods are provided with the usual packing-rings to make snug joints and prevent the escape of pressure. The cylinders 2, 2, and 3 are preferably mounted upon a shaft inclosing base portion 14, which surrounds a portion of the main shaft 10 and the cranks 9 9. This inclosing base portion not only incloses the shaft and the cranks, but also serves a further purpose, as will be more fully described. A suitable explosive mixture is led to the high-pressure cylinders through piping 15 15, which is connected with valve-chambers 16 16. A valve, as 17, normally held closed by means of a spring 18, is mounted in the valve-casing 16. Below the valve 17 an inlet-port 19 is located, leading into one of the high-pressure cylinders 2. As the piston in the high-pressure cylinder descends it will suck or draw

55

60

65

70

75

80

85

90

95

100

the charge of explosive mixture from the pipe 15 past the valve 17, through the port 19, into the upper end of the cylinder. Upon the upward stroke of the piston the spring 18 will be permitted to close the valve 17 to prevent the back flow of the gaseous mixture, and the piston will compress the said explosive mixture in the upper end of the cylinder. At the proper time the said mixture will be ignited and its explosive force will force the piston downwardly. In order to ignite the gaseous mixture, I provide suitable electrodes, as at 20 and 21, the electrode 20 being provided with an annular projecting ridge adapted to snap by the electrode 21 for producing an electric spark, said electrodes being each connected with the poles of a battery. (Not shown.) The stem of the electrode 20 extends downwardly outside the casing and is provided with a collar, as 22, between which and the casing is interposed a spring 23 for holding the said electrode normally in its lowered position. Each of the electrodes will be raised at the proper time by mechanism which will be hereinafter described. The valve-casing 16 is also provided with a port 24, which leads into the low-pressure cylinder 3. A valve 25 controls the admission of the exhausted gases to the said port 24, the stem of the said valve extending downwardly and having a spring 26 secured thereto for holding the valve 25 normally upon its seat. The valve 25 is operated by a suitable means for opening the port 24 to the exhaust and admitting the exhausted gases to the low-pressure cylinder, as will be hereinafter more fully described. The cylinder 3 is also provided with an exhaust-port 27, (seen in Fig. 3,) which is controlled by means of a spring-pressed valve, as 28. The cylinder 3 is also provided with an air-inlet valve, as 29, mounted in a suitable casing and normally held closed by means of a spring 30. A piping, as 31, connects the valve-casing with the compressed-air supply, and a port 32 admits the said compressed air through the valve-casing to the cylinder 3. This compressed-air inlet may be used to assist in running the engine continually in connection with the explosive mixtures, but is preferably used only in starting the engine, it not being necessarily needed for the further operation of the device.

In order to operate the valves above described, a counter-shaft, as 33, is mounted in the casing 14 14 and arranged parallel with the main shaft 10. At a suitable point along the length of the said shaft an inclined shaft 34 is mounted in suitable bearings and provided with spiral gears 35 36, which mesh, respectively, with spiral gears 37 on the shaft 10 and 38 on the shaft 33 for communicating motion from one shaft to the other. Arranged directly beneath the stems of the valves 25 are vertical rods 39, which are held in their lower position normally by means of springs 40, surrounding the said rods and in-

terposed between heads upon the lower ends thereof and the casing 14 14. Pivoted levers 41, mounted upon the casing, engage the lower ends of the said vertical rods and rest upon cams, as 42, secured to the shaft 33. These cams are so located upon the said shafts that they will open the valves 25 to admit the exhaust from the high-pressure cylinders into the low-pressure cylinder alternately, the explosion in each of the high-pressure cylinders taking place upon every other stroke of the piston. Similar rods, as 43, engage cams 44 on the shaft 33 to operate the electrodes 20 22. A rod 45, engaging a cam 46, is adapted to operate the air-inlet valve 29 when it is desired to use compressed air in the low-pressure cylinder. When it is not desired to employ compressed air, a pivoted end portion 47 on the lower end of the stem of the valve 29 is turned up out of the way, so as not to engage the said rod 45. It will be noted that whenever it is desired to employ compressed air the pin 47 can be immediately turned down, so as to throw the valve 29 into operation. A similar cam-actuating rod 48 is adapted to control the movement of the exhaust-valve 28.

While the exhausts from the low-pressure cylinder may be conducted to any suitable point, yet I preferably utilize the heat of the said exhaust for expanding the compressed air, and thereby giving the same additional power. For this purpose the exhaust is conducted through a larger pipe 49 into a compartment 50, formed upon the casing 14. A spring-pressed valve 51 controls the entrance of the exhaust from the compartment 50 into the interior of a compartment 56 in the casing 14, formed by means of a partition 57. The said compartment is tightly closed and is provided with an outlet, as at 52, which is provided with a valve 53, normally held closed by means of springs 54 and 55. By the construction thus described it will be noted that the movement of one of the high-pressure pistons, as 7, may be utilized for pumping the exhaust from the chamber 50 into the chamber 56 and forcing the same out through the valve 52. The exhaust thus pumped out of the casing may be conducted to the compressed-air tank, if desired, by connecting the casing of the valve 52 by means of suitable piping with the said tanks. It will be noted that the construction of the valve 51 is such that the exhaust cannot return into the chamber 50. As the piston 7 ascends it will create a vacuum in the chamber 56 and draw the exhaust from the chamber 50. When it descends again, the valve 51 will be closed and the exhaust will be forced out of the compartment 56. I thus use the piston 7 for pumping the exhaust in the same manner as any other vacuum-pump would be used. The pipe 50^a, which leads the compressed air from any suitable source to the low-pressure cylinder, is passed in a zigzag manner through the chamber 50, so that the air therein is entirely heated, and thus give great additional expansive power.

I find that it is convenient and practicable to employ, in connection with one of the high-pressure cylinders, a smaller piston-surface for compressing air into suitable tanks for use in the engine elsewhere. The piston 6 is provided with a hollow cylinder extension 58, forming a smaller piston and moving in an extension 59 of the cylinder 2. The outer end of the piston 58 is provided with a valve-controlled opening, as at 60, the valve at this point being normally held closed by means of a spring 61. The end of the cylinder 59 is preferably closed by means of a valve-casing 62, provided with a spring-pressed valve 63. The valve-casing is connected by means of suitable piping, as 64, with suitable air-reservoirs or tanks for storing air for further use. These tanks may be of any suitable size and may be located to one side of the engine, as at 65 in Fig. 1, or the tanks may be secured to the casing 14, as at 66, if desired, without departing in the least from the spirit of my invention. As the piston 6 reciprocates it will, upon its downward movement, permit air to pass upwardly through the piston extension 58 into the vacuum produced between the valves 65 and the end of the said piston extension, the valve 60 permitting the air to pass into the cylinder extension 59. When the piston 6 ascends, and with it the piston extension 58, the valve 60 will be closed and will force the air past the valve 63 and through the rod 64 into the storing-tanks. By thus using a piston which has a comparatively small compressing-surface in connection with the gas-cylinder piston of much larger area I am enabled to compress air with very little loss of power.

As seen in Fig. 1 of the drawings, the compressed-air tanks may be connected by suitable piping, as 65^a, with the low-pressure cylinder, conducting the air from the said tanks to the valve 29 for use as above described. The compressed air may be also utilized for other purposes.

Upon the upper end of one of the cylinders 2 is preferably located an air-cylinder 4, which may be bolted or otherwise secured in place upon the said cylinder. A piston, as 67, moves in the said air-cylinder 4 and is connected by means of its piston-rod 68 with the piston 7. A suitable packing is arranged about the said piston-rod 68 where it passes through the head of the cylinder 2. This head may be formed with a water-jacket, as at 69, if desired, to prevent the excessive heat from injuring the parts at this point. The cylinder 4 is provided with a valve-casing, as 70, in which a slide-valve 71 of ordinary construction is adapted to move. The said slide-valve may be reciprocated by connecting it by means of an eccentric, as 71^a, with the main shaft 10, as clearly illustrated in Figs. 1 and 2 of the drawings. A valve-casing 70 is connected with each end of the cylinder 4 by means of suitable ports and with an exhaust-pipe 72, leading from the said cylinder and

valve-chest into the low-pressure cylinder 3. A pipe, as 73, connects the valve-casing 70 with suitable piping leading from the air-tanks, so that the compressed air may be applied in the valve-chest 70. The compressed air may be thus used at any time to assist in running the engine by using the cylinder 4 for reciprocating the piston 67, and thus the piston 6, as has been clearly described and illustrated. In order not to lose the exhaust of the said air-cylinder, it is preferably led, by means of said pipe 72, into a low-pressure cylinder 3 to give additional power to the said cylinder.

It will be apparent that instead of employing an air-compressor, as at 58, I may run an air-compressor which is separate from the engine for accumulating air compressed in the tanks without departing from the spirit of my invention.

It will be apparent from the above description that I have produced a gas-engine which is capable of compound action, having high and low pressure cylinders, the high-pressure cylinders being adapted to exhaust into the low-pressure cylinders, and that I am also enabled to compress air in suitable tanks or other reservoirs and utilize the same not only in the low-pressure cylinder but in an auxiliary air-cylinder having a piston arranged in tandem with the piston in the high-pressure cylinders; also, by pumping the exhaust through the exhaust-chamber I am enabled to further utilize the heat of the said exhaust for expanding the compressed air. It will be apparent from the drawings that the cranks upon the main power-shaft are arranged so that those connected with the high-pressure piston are diametrically opposite the one connected with the low-pressure cylinder, in order to secure the proper operation of the compound movement.

It will be understood that I contemplate using any sort of expansive power in the operation of my engine, such as gas mixtures of various kinds, carbonic-acid gas, liquefied air, or other air compressed to a less degree, all within the spirit of my invention.

It will be noted that my engine is a compound gas and air engine in that it employs high-pressure gas-cylinders which exhaust into a low-pressure cylinder and that it also employs high-pressure air-cylinders which exhaust into a low-pressure cylinder. It will also be noted that the low-pressure cylinder receives the exhaust both from the high-pressure gas-cylinders and the high-pressure air-cylinders.

Having now described my invention, what I claim as new, and desire to secure by Letters Patent, is—

1. In an air and gas engine, the combination with high and low pressure cylinders, of an air-cylinder arranged upon one end of one of the high-pressure cylinders, the piston of which is connected up with the piston of the high-pressure cylinder, an air-compressor

mounted upon the end of the other high-pressure cylinder, means for storing the air compressed, and piping for leading the compressed air to the air-cylinder or to the low-pressure cylinder as may be desired, substantially as described.

2. In a gas-engine, the combination with two high-pressure cylinders and one low-pressure cylinder, a main shaft connected with the pistons in the said cylinders, a casing enclosing the said shafts and cranks carried thereby, a compartment formed beneath one of the said high-pressure cylinders and provided with inlet and outlet valves, a heating-compartment connected with the said compartment in the casing, means for conducting the exhaust from the low-pressure cylinder to the said heating-compartment, the construction being such that the operation of the pistons in the high-pressure cylinders will tend to produce a vacuum in the casing so as to pump the exhaust from the said chamber into the casing and force the same out in the open air, substantially as described.

3. In a gas-engine, the combination with high and low pressure cylinders, of an air-compressor connected with one of the said high-pressure cylinders and comprising a cylinder extension formed upon one end of the said compression-cylinder, a piston extension formed upon the piston of the said cylinder, a valve in the end of the said piston extension, a valve controlling the end of the said cylinder extension, means for connecting the said outlet from the said cylinder extension with a suitable reservoir or tank, and means for admitting explosive mixtures to the high-pressure cylinders for operating them, the construction being such that as the high-pressure cylinders reciprocate, the piston extension will be so reciprocated in the cylinder extension as to compress air and force the same into suitable reservoirs for further use, substantially as described.

4. In a gas-engine, the combination with suitable cylinders adapted to be operated by an explosive mixture, of an air-cylinder arranged upon the end of one of the said explosive-mixture cylinders, a piston moving in the said air-cylinder and connected with the piston in the explosive-mixture chamber, a valve-chest connected with each end of the said air-cylinder and means for admitting compressed air or other pressure to the said valve-chest, the construction being such that the piston in the air-cylinder will assist the piston in the explosive-mixture cylinder in running the engine, substantially as described.

5. In an air and gas engine, the combination with suitable cylinders, of a compressor attached to the piston of one of the cylinders, a compressed-air piston connected with another cylinder, reservoirs for collecting air which is compressed and piping for leading the said air to the air-operated cylinder for as-

sisting in the operation of the engine, and means for conducting the exhaust from the air-cylinder, to one of the cylinders of the engine for further assisting in the operation thereof, substantially as described.

6. In an air and gas engine, the combination with high and low pressure cylinders, of pistons operating therein, an air-compressor mounted upon one of the said cylinders, an air-operated cylinder mounted upon another of the said cylinders, reservoirs for receiving the air which is compressed, piping for conducting the compressed air to the air-cylinder, a heating-compartment surrounding a portion of the said piping and adapted to receive the exhaust from the low-pressure cylinder, means for piping the said exhaust to the air-cylinder, a heating-compartment enclosing a portion of the said piping, means for pumping the exhaust from the low-pressure cylinder through the said compartment, whereby the heat of the said exhaust will be imparted to the compressed air for giving it further expansive power, substantially as described.

7. In an air and gas engine, the combination of high and low pressure cylinders, of means for compressing air in suitable reservoirs, means for admitting compressed air to the low-pressure cylinder for starting the engine, a valve controlling the admission of the said compressed air, the stem of the said valve extending opposite the casing, a pivoted end portion mounted upon the said valve-stem and a valve-operating rod for lifting the said valve, the construction being such that when the pivoted end of the valve-stem is in its straightened position, the valve will be operated to admit air to the low-pressure cylinder and when the said pivoted end is turned upwardly, the said valve will cease to be operated, substantially as described.

8. In a compound air and gas engine, the combination with high-pressure gas-cylinders, of a low-pressure cylinder adapted to receive the exhaust therefrom, an air-pressure cylinder also adapted to exhaust into the said low-pressure cylinder, the same low-pressure cylinder receiving the exhaust from both the air-cylinder and the gas-cylinders, substantially as described.

9. In a compound gas and air engine, the combination with high-pressure gas-cylinders and high-pressure air-cylinders, of a low-pressure cylinder adapted to receive and be operated by the exhaust from both the high-pressure gas-cylinders and the high-pressure air-cylinders, and a vacuum-chamber for drawing the exhaust from the said low-pressure cylinder, substantially as described.

In testimony whereof I hereunto affix my signature in presence of two witnesses.

JOHN W. EISENHUTH.

Witnesses:

CHARLES H. GRAHAM,
JOHN A. HILTON.