



(19) **United States**

(12) **Patent Application Publication**
Smith et al.

(10) **Pub. No.: US 2010/0120928 A1**

(43) **Pub. Date: May 13, 2010**

(54) **MIX OF GRAFTED AND NON-GRAFTED PARTICLES IN A RESIN**

Publication Classification

(76) Inventors: **James D. B. Smith**, Monroeville, PA (US); **Gary Stevens**, Surrey (GB); **John W. Wood**, Winter Springs, FL (US)

(51) **Int. Cl.**
C08J 9/00 (2006.01)
C08L 63/00 (2006.01)
C08K 9/00 (2006.01)

(52) **U.S. Cl. 521/50; 523/400; 523/200; 523/440**

Correspondence Address:
SIEMENS CORPORATION
INTELLECTUAL PROPERTY DEPARTMENT
170 WOOD AVENUE SOUTH
ISELIN, NJ 08830 (US)

(57) **ABSTRACT**

In one application the mix grafted and non grafted invention provides for high thermal conductivity resin that comprises a host resin matrix **32** with a first class of grafted **31** high thermal conductivity particles that are grafted to the host resin matrix. Also a second class of non-grafted **30** high thermal conductivity particles that are not directly grafted the host resin matrix **32**. The first class and the second class comprise approximately 2-60% by volume of the high thermal conductivity resin. The first class of grafted particles and the second class of non-grafted particles are high thermal conductivity fillers are from 1-1000 nm in length, and have an aspect ratio of between 3-100.

(21) Appl. No.: **12/695,279**

(22) Filed: **Jan. 28, 2010**

Related U.S. Application Data

(63) Continuation of application No. 11/396,989, filed on Apr. 3, 2006, now Pat. No. 7,655,295, which is a continuation-in-part of application No. 11/152,986, filed on Jun. 14, 2005.

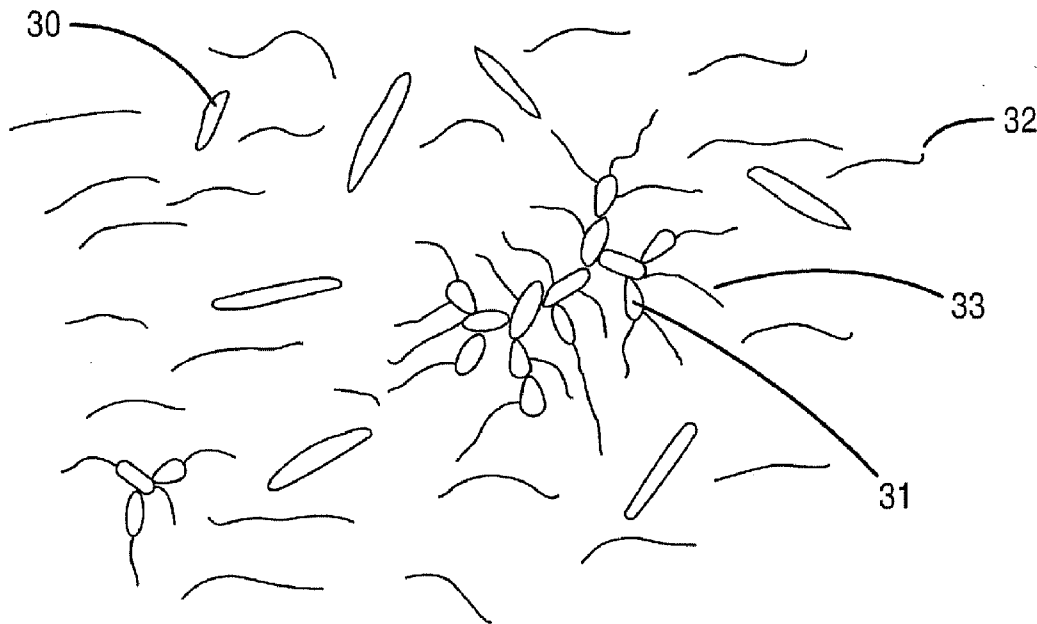

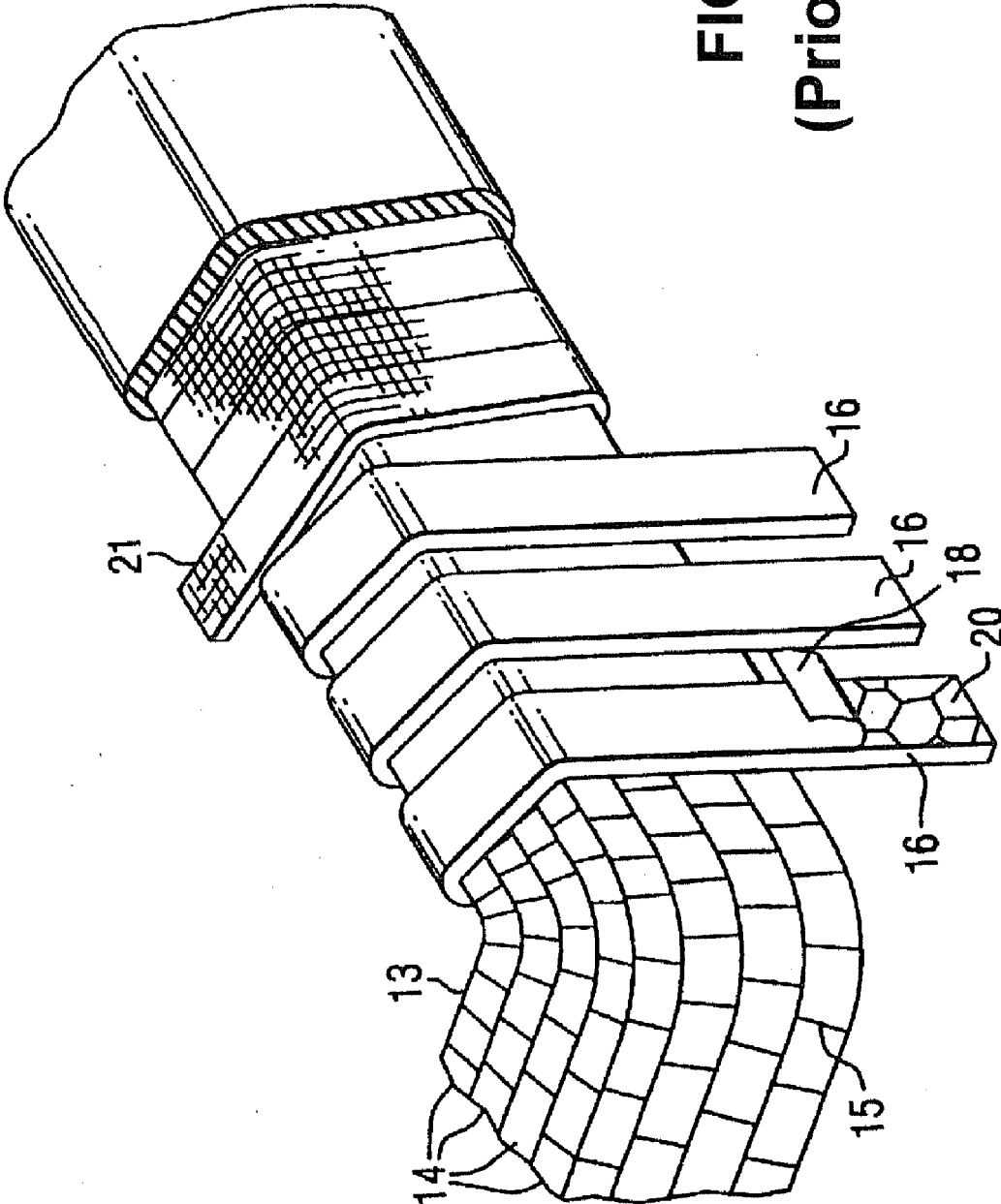

FIG. 1
(Prior Art)

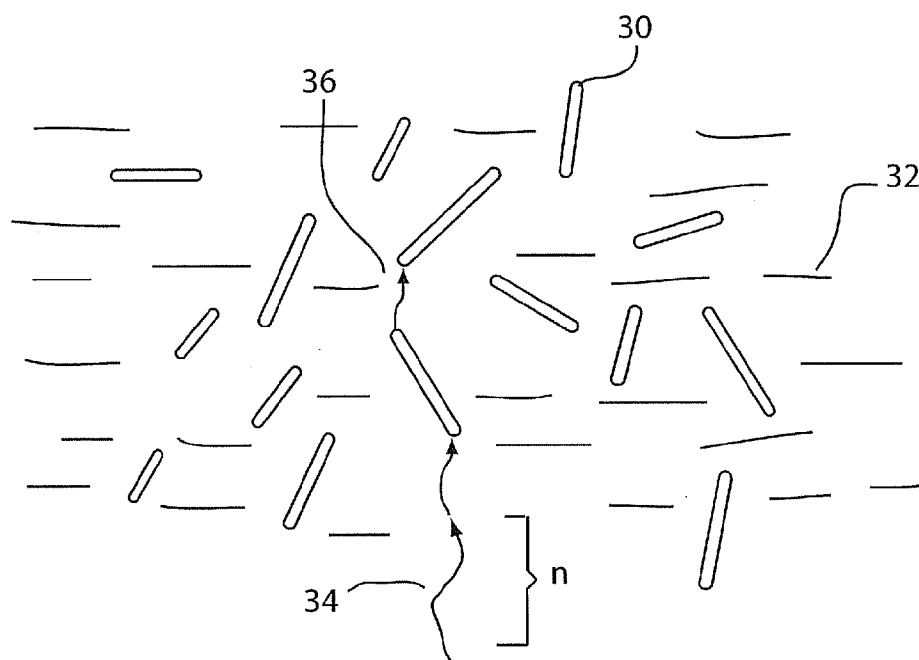

FIG. 2



FIG.3

MIX OF GRAFTED AND NON-GRAFTED PARTICLES IN A RESIN

CROSS-REFERENCE TO RELATED APPLICATIONS

[0001] This application is a continuation-in-part of U.S. application Ser. No. 11/152,986, "High Thermal Conductivity Materials with Grafted Surface Functional Groups" filed Jun. 14, 2005, by Smith, et al., which is incorporated herein by reference.

FIELD OF THE INVENTION

[0002] The field of the invention relates to high thermal conductivity materials with surface grafted functional groups impregnated into resins.

BACKGROUND OF THE INVENTION

[0003] With the use of any form of electrical appliance, there is a need to electrically insulate conductors. With the push to continuously reduce the size and to streamline all electrical and electronic systems there is a corresponding need to find better and more compact insulators and insulation systems.

[0004] Various epoxy resin materials have been used extensively in electrical insulation systems due to their practical benefit of being tough and flexible electrical insulation materials that can be easily adhered to surfaces. Traditional electrical insulation materials, such as mica flake and glass fiber, can be surface coated and bonded with these epoxy resins, to produce composite materials with increased mechanical strength, chemical resistance and electrical insulating properties. In many cases epoxy resins have replaced traditional varnishes despite such materials having continued use in some high voltage electrical equipment.

[0005] Good electrical insulators, by their very nature, also tend to be good thermal insulators, which is undesirable. Thermal insulating behavior, particularly for air-cooled electrical equipment and components, reduces the efficiency and durability of the components as well as the equipment as a whole. It is desirable to produce electrical insulation systems having maximum electrical insulation and minimal thermal insulation characteristics.

[0006] Electrical insulation often appears in the form of insulating tapes, which themselves have various layers. Common to these types of tapes is a paper layer that is bonded at an interface to a fiber layer, both layers tending to be impregnated with a resin. A favored type of insulation material is a mica-tape. Improvements to mica tapes include catalyzed mica tapes as taught in U.S. Pat. No. 6,103,882. The mica-tape may be wound around conductors to provide extremely good electrical insulation. An example of this is shown in FIG. 1. Illustrated here is a coil **13**, comprising a plurality of turns of conductors **14**, which in the example illustrated here are assembled into a bakelized coil. The turn insulation **15** is prepared from a fibrous material, for example glass or glass and Dacron which is heat treated. Ground insulation for the coil is provided by wrapping one or more layers of composite mica tape **16** about the bakelized coil **14**. Such composite tape may be a paper or felt of small mica flakes combined with a pliable backing sheet **18** of, for example, glass fiber cloth or polyethylene glycol terephthalate mat, the layer of mica **20** being bonded thereto by a liquid resinous binder. Generally, a plurality of layers of the composite tape **16** are wrapped about

the coil depending upon voltage requirements. A wrapping of an outer tape **21** of a tough fibrous material, for example, glass fiber, may be applied to the coil.

[0007] Generally, multiple layers of the mica tape **16** are wrapped about the coil with sixteen or more layers generally being used for high voltage coils. Resins are then impregnated into the tape layers. Resins can even be used as insulation independently from the insulating tape. Unfortunately this amount of insulation only further adds to the complications of dissipating heat. What is needed is electrical insulation that can conduct heat higher than that of conventional methods, but that does not compromise the electrical insulation and other performance factors including mechanical and thermal capability.

[0008] Other difficulties with the prior art also exist, some of which will be apparent upon further reading.

SUMMARY OF THE INVENTION

[0009] With the foregoing in mind, methods and apparatuses consistent with the present invention, which inter alia facilitates the transport of phonons through a high thermal conductivity (HTC) impregnated medium to reduce the mean distances between the HTC materials below that of the phonon mean free path length. This reduces the phonon scattering and produces a greater net flow or flux of phonons away from the heat source. The resins may then be impregnated into a host matrix medium, such as a multi-layered insulating tape.

[0010] High Thermal Conductivity (HTC) organic-inorganic hybrid materials may be formed from discrete two-phase organic-inorganic composites, from organic-inorganic continuous phase materials based on molecular alloys and from discrete organic-dendrimer composites in which the organic-inorganic interface is non-discrete within the dendrimer core-shell structure. Continuous phase material structures may be formed which enhance phonon transport and reduce phonon scattering by ensuring the length scales of the structural elements are shorter than or commensurate with the phonon distribution responsible for thermal transport, and/or that the number of phonon scattering centers are reduced such as by enhancing the overall structural order of the matrix, and/or by the effective elimination or reduction of interface phonon scattering within the composite. Continuous organic-inorganic hybrids may be formed by incorporating inorganic, organic or organic-inorganic hybrid nano-particles in linear or cross-linked polymers (including thermoplastics) and thermosetting resins in which nano-particles dimensions are of the order of or less than the polymer or network segmental length (typically 1 to 50 nm or greater). These various types of nano-particles may contain reactive surfaces to form intimate covalently bonded hybrid organic-inorganic homogeneous materials. Similar requirements exist for inorganic-organic dendrimers which may be reacted together or with matrix polymers or reactive resins to form a continuous material. In the case of both discrete and non-discrete organic-inorganic hybrids it is possible to use sol-gel chemistry to form a continuous molecular alloy. The resulting materials will exhibit higher thermal conductivity than conventional electrically insulating materials and may be used as bonding resins in conventional mica-glass tape constructions, when utilized as unreacted vacuum-pressure impregnation resins and as stand alone materials to fulfill electrical insulation applications in rotating and static electrical power plant and in both high (approximately over 5 kV) and low voltage (approximately under 5 kV) electrical equipment, components and products.

[0011] The formation of engineered electrical insulation materials having prescribed physical properties and performance characteristics, and based on the use of nano-to-micro sized inorganic fillers in the presence of organic host materials, requires the production of particle surfaces which can form an intimate interface with the organic host. This may be achieved through the grafting of chemical groups onto the surface of the fillers to make the surface chemically and physically compatible with the host matrix, or the surfaces may contain chemically reactive functional groups that react with the organic host to form covalent bonds between the particle and the host. The use of nano-to-micro sized inorganic fillers in the presence of organic host materials requires the production of particles with defined surface chemistry in addition to bulk dielectric and electrical properties and thermal conductivity. Most inorganic materials do not allow independent selection of structural characteristics such as shape and size and properties to suit different electrical insulation applications or to achieve composites having the right balance of properties and performance. This may be achieved by selecting particles with appropriate bulk properties and shape and size characteristics and then modifying the surface and interfacial properties and other characteristics to achieve the additional control of composite properties and performance required for electrical insulation applications. This may be achieved by appropriate surface coating of the particles which may include the production of metallic and non-metallic inorganic oxides, nitrides, carbides and mixed systems and organic coatings including reactive surface groups capable of reacting with appropriate organic matrices which act as the host material in the electrical insulation system. The resulting hybrid materials and composites in unreacted or partially reacted form may be used as bonding resins in mica-glass tape constructions, as unreacted vacuum-pressure, and global vacuum-pressure impregnation resins for conventional mica tape constructions, in other glass fiber, carbon fiber and ply-type and textile composites and as stand alone materials to fulfill electrical insulation applications in rotating and static electrical power plant and in both high and low voltage electrical equipment, components and products.

[0012] In addition to using grafted HTC particles, the present invention uses a mix of grafted and non grafted HTC particles in the final loaded resin. The grafted and non grafted classes of particles can each contain the full range of HTC particles discussed, although certain applications may favor different particles in the different classes. Both classes can also have additional surface treatment for various effects.

[0013] In one application the mix grafted and non grafted invention provides for high thermal conductivity resin that comprises a host resin matrix with a first class of grafted high thermal conductivity particles that are grafted to the host resin matrix. Also, a second class of non-grafted high thermal conductivity particles that are not directly grafted to the host resin matrix. The first class and the second class comprise approximately 2-60% by volume of the high thermal conductivity resin. The first class of grafted particles and the second class of non-grafted particles are high thermal conductivity fillers are from 1-1000 nm in length, and have an aspect ratio of between 3-100.

[0014] In particular embodiments the first class and the second class comprise approximately 25-40%. The second class of non-grafted particles can be surface treated to not react with other particles with their class. Also, the second class of non-grafted particles can be surface treated to react

with other particles with their class to form aggregations within the host resin matrix. And the first class of grafted particles can be surface treated to react with the second class of non-grafted particles.

[0015] In other particular embodiments the first class of grafted particles have an average length distribution at least ten times greater than the second class of non-grafted particles. The host resin network includes epoxy, polyimide-epoxy, liquid crystal epoxy, cyanate-ester, polybutadiene, and appropriate mixtures of the foregoing. The high thermal conductivity resin is impregnated into a composite tape, and the second class of non-grafted particles can be incorporated into the high thermal conductivity resin after the high thermal conductivity resin is impregnated into the composite tape.

[0016] In still other embodiments non grafted becomes grafted to the host resin by the application of at least one of increased temperature and ultraviolet light. The thermal conductivity particles are at least one of oxides, nitrides, and carbides.

[0017] In another application the mix grafted and non grafted invention provides for high thermal conductivity resin that comprises a host resin matrix, a first class of grafted high thermal conductivity particles that are grafted to the host resin matrix, and a second class of non-grafted high thermal conductivity particles that are not grafted to the host resin matrix. Although the first class of particles may provide some thermal conductivity benefit, they do not necessarily have to be of the HTC type particle described herein. The first class and the second class comprise approximately 4-60% by volume of the high thermal conductivity resin. The first class of grafted particles and the second class of non-grafted particles are high thermal conductivity fillers are from 5-1000 nm in length, and have an aspect ratio of between 3-100, and each of the classes of particles comprises at least 1% by volume of high thermal conductivity resin. In some cases the first class of grafted particles have a higher mechanical strength than the second class of non-grafted particles.

[0018] In a particular embodiment the resin is impregnated into a porous media, such as a paper or glass fiber matrix or printed circuit boards. The ratios of the first class of grafted particles and the second class of non-grafted particles can be made different in different parts of the porous media due to a greater filtering effect that the porous media has on the second class of non-grafted particles. In some cases the ratios of the first class of grafted particles and the second class of non-grafted particles are different in different parts of the porous media due to the original positioning of the particles.

[0019] In still another application the mix grafted and non grafted invention provides for a high thermal conductivity resin that comprises a host resin matrix and a first class of grafted particles that are grafted to the host resin matrix, the grafted particles increase the local strength of the host resin matrix. Also, a second class of non-grafted high thermal conductivity particles that are not grafted to the host resin matrix. The first class and the second class comprise approximately 2-60% by volume of the high thermal conductivity resin, and the second class of non-grafted particles are high thermal conductivity fillers are from 1-1000 nm in length, and have an aspect ratio of between 3-100.

[0020] In particular embodiments the second class of non-grafted particles have an average length of 2-10 times that of the first class of grafted particles. Applications of this embodiment include the longer, non-grafted particles increasing the thermal conductivity, while the shorter grafted

particles increase localized strength of the resin. In some embodiments a third class of non-grafted particles that are not high thermal conductivity particles are present in the host resin matrix.

[0021] In other particular embodiments at least a portion of the first class of grafted particles are high thermal conductivity fillers from 1-1000 nm in length, and have an aspect ratio of between 3-100. In other embodiments the grafted particles increase the dielectric strength of the host resin matrix.

[0022] Other embodiments of the present invention also exist, which will be apparent upon further reading of the detailed description.

BRIEF DESCRIPTION OF THE FIGURES

[0023] The invention is explained in more detail by way of example with reference to the following drawings:

[0024] FIG. 1 shows the use of an insulating tape being lapped around a stator coil.

[0025] FIG. 2 illustrates phonons traveling through a loaded resin of the present invention.

[0026] FIG. 3 illustrates one embodiment of the present invention where smaller grafted particles have been surface treated to aggregate while longer non grafted particles have been surface treated to more evenly disperse.

DETAILED DESCRIPTION OF THE INVENTION

[0027] High thermal conductivity (HTC) composites comprise a resinous host network combined with fillers that are two phase organic-inorganic hybrid materials. The organic-inorganic hybrid materials are formed from two phase organic-inorganic composites, from organic-inorganic continuous phase materials that are based on molecular alloys, and from discrete organic-dendrimer composites in which the organic-inorganic interface is non-discrete with the dendrimer core-shell structure. Phonon transport is enhanced and phonon scattering is reduced by ensuring the length scales of the structural elements are shorter than or commensurate with the phonon distribution responsible for thermal transport.

[0028] Two phase organic-inorganic hybrids may be formed by incorporating inorganic micro, meso or nano-particles in linear or cross linked polymers (thermoplastics) and thermosetting resins. Host networks include polymers and other types of resins, definitions of which are given below. In general, the resin that acts as a host network may be any resin that is compatible with the particles and, if required, is able to react with the groups introduced at the surface of the filler. Nano-particle dimensions are typically of the order of or less than the polymer network segmental length. For example 1-30 nm. The inorganic particles contain reactive surfaces to form covalently bonded hybrid organic-inorganic homogeneous materials. The particles may be oxides, nitrides, carbides and hybrid stoichiometric and non-stoichiometric mixes of the oxides, nitrides and carbides, more examples of which are given below.

[0029] The inorganic particles are surface treated to introduce a variety of surface functional groups which are capable of participating in reactions with the host network. The surface functional groups include but are not limited to hydroxyl, carboxylic, amine, epoxide, silane and vinyl groups. The groups may be applied using wet chemical methods, non-equilibrium plasma methods, chemical vapor and physical vapor deposition, sputter ion plating and electron and ion beam evaporation methods.

[0030] The discrete organic-dendrimer composites may be reacted together or with the resin matrix to form a single material. The surface of the dendrimer can contain reactive groups similar to those mentioned above, which will either allow dendrimer-dendrimer or dendrimer-organic matrix reactions to occur. The dendrimer will have an inorganic core and an organic shell containing the reactive groups of interest. It may also be possible to have an organic core with an inorganic shell which also contains reactive groups such as hydroxyl or silane groupings which can participate in inorganic reactions similar to those involved in common sol-gel chemistries.

[0031] In regards to the use of non-discrete organic-inorganic hybrids it is possible to use sol-gel chemistry to form a continuous molecular alloy. Gel sol-chemistries involving aqueous and non-aqueous reactions may be used. Other compounds for the formation of organic-inorganic hybrids include the polyhedral oligomeric silsesquioxanes (POSS), tetraethyl orthosilicate (TEOS) and tetrabutyl orthotitanate (TBOT) and related monomeric and oligomeric hybrid compounds which are organic functionalized inorganic compounds. In the example of POSS, molecules are built around a building block of $R-SiO_{1.5}$ in which the R group is chosen to compatibilize with and/or react with other organic compounds and the host network. The base compounds may be combined to yield larger molecules commensurate with the size of polymer segment and coil structures. POSS may be used to create organic-inorganic hybrids and may be grafted into existing polymers and networks to control properties, including thermal conductivity. The materials may be obtained from suppliers such as Aldrich™ Chemical Co., Hybrid Plastics™ Inc. and Gelest™ Inc.

[0032] As mentioned, it is important to control the structural form of the materials to reduce phonon scattering. This can be further assisted by using nano-particles whose matrices are known to exhibit high thermal conductivity and to ensure that the particles size and its interfacial characteristics with the resin are sufficient to sustain this effect, and also to satisfy the length scale requirement to reduce phonon scattering. A choice of structures that are more highly ordered will also benefit this, including reacted dendrimer lattices having both short and longer range periodicity and ladder or ordered network structures that may be formed from a host resin, such as liquid crystal epoxies and polybutadienes.

[0033] The filled resins may be used as bonding resins in a variety of industries such as circuit boards and insulating tapes. A particular kind of insulating tape is the mica-glass tape used in the electrical generator fields. Resins with these types of tapes can be used as bonding resins, or as impregnating resins as is known in the art. The filled resin may also be used in the electrical generator field without the tapes to fulfill electrical insulation applications in the rotating and static electrical equipment components.

[0034] The tapes may be impregnated with resin before or after being applied to electrical objects. Resin impregnation techniques include VPI and GVPI, discussed more below. In VPI, once a tape is lapped and impregnated it is compressed. Once in position, the resin in the compressed tape is cured, which effectively locks the position of the HTC materials. In some embodiments the resin is cured in a two stage process, as will be apparent to one of ordinary skill in the art. However, optimal compression of the loaded HTC materials favors a completely uncured resin during the compression stage.

[0035] FIG. 2 shows one embodiment of the present invention. Illustrated here are HTC materials **30** loaded into a resinous matrix **32**. Phonons **34** traveling through the matrix have a mean path length n ; this is the phonon mean free path. This path length can vary depending on the exact composition of the resin matrix, but is generally from 2 to 100 nm, and more typically 5-50 nm, for resins such as epoxy resins. Therefore the mean distance between the loaded HTC materials should be on average less than this distance. Note that the distance between the HTC materials can vary in the thickness versus transverse direction of the tape, and it is generally the thickness direction where the spacing needs to be optimized.

[0036] As phonons **34** travel through the resin **32** they will tend to pass along the embedded HTC materials **30**. This will increase the local phonon flux since the raw HTC materials will have a thermal conductivity of between 10-1000 W/mK, as opposed to the resin which is about 0.1-0.5 W/mK. As phonons pass along a loaded HTC material the phonons **36** pass to the next HTC material if the distance between the materials is less than n , therefore the HTC materials form an interconnecting network. FIG. 2 illustrates an idealized path. In practice there will be phonon scattering as the phonons pass between the resin and HTC materials, although the shorter the distance between the materials, and the better the match of phonon propagation characteristics between the HTC materials and the resin, the less the scattering.

[0037] The amount of HTC materials loaded in the resin could actually be quite low, for example about 10% as illustrated in FIG. 2. The average distances, or length scales, between loaded HTC materials therefore may be slightly greater than n , however, a large percentage will still be less than n and therefore fall within embodiments of the present invention. In particular embodiment, the percentage materials that are less than n distance from the next HTC material is over 50%, with particular embodiment being over 75%. In particular embodiment the average length of the HTC materials is greater than n , which further aids in phonon transport.

[0038] The shorter n the greater the concentration of loaded HTC materials, and conversely, the greater the particle size, the less HTC materials needed. Particular embodiment use 5-60% loaded HTC materials by total volume of the resins and fillers, with more particular embodiments at 25-40%. When the resin is impregnated into the tape, it will fill up the spaces between the tape fibers and substrates. The HTC distribution within the tape at this point, however, is often not optimized, and can even have the mean distance between HTC materials greater than n . Practice of the present invention then compresses the resin impregnated tapes and reduces the distances between the loaded HTC materials.

[0039] When a loaded resin is being impregnated into a tape, the fibers or particles of the tape act to block some of the HTC materials, particularly if the resin is 30% or more filler. However, by compressing the tapes, the reverse happens, and more fillers are trapped within the tape as the HTC materials attach themselves to non-mobile parts of the overall structure. The HTC fillers even get pinned to one another. In the embodiments given, it has been implied that the fillers do not react with the resin matrix, however, in some embodiments the fillers do form covalent bonds with the resin and form more homogeneous matrixes. In a homogenous matrix, the resin molecules that are bound to fillers will be retained better than the unbound resin molecules during compression.

[0040] Resins are used in a plurality of industries, and have a large number of uses. Different properties of the resins affect not only their uses, but also the quality and efficiency of the products that they are used with. For example, when resins are used in electrical insulation applications, their characteristics of dielectric strength and voltage endurance needs to be high, as does the thermal stability and thermal endurance. However, often contrary to these objectives, resins usually will also have a low thermal conductivity. The present invention balances the various physical properties of resins and the insulation system they are introduced into to produce a system that has a higher thermal conductivity than conventional electrically insulating materials while maintaining adequate, and even enhancing, key physical properties such as dielectric strength, voltage endurance, thermal stability and thermal endurance, mechanical strength and viscoelastic response. Delamination and microvoid formation resulting from stresses caused by thermal, vibration and mechanical cycling effects are reduced or eliminated. As used herein, the term resin refers to all resins and epoxy resins, including modified epoxies, polyesters, polyurethanes, polyimides, polyesterimides, polyetherimides, bismaleimides, silicones, polysiloxanes, polybutadienes, cyanate esters, hydrocarbons etc. as well as homogeneous blends of these resins. This definition of resins includes additives such as cross-linking agents, accelerators and other catalysts and processing aids. Certain resins, such as liquid crystal thermosets (LCT) and 1,2 vinyl polybutadiene combine low molecular weights characteristics with good crosslinking properties. The resins can be of an organic matrix, such as hydrocarbons with and without hetero atoms, an inorganic matrix, containing silicate and/or alumino silicate components, and a mixture of an organic and inorganic matrix. Examples of an organic matrix include polymers or reactive thermosetting resins, which if required can react with the reactive groups introduced on inorganic particle surfaces. Cross-linking agents can also be added to the resins to manipulate the structure and segmental length distribution of the final crosslinked network, which can have a positive effect on thermal conductivity. This thermal conductivity enhancement can also be obtained through modifications by other resin additives, such as catalysts, accelerators and other processing aids. Certain resins, such as liquid crystal thermosets (LCT) and 1,2 vinyl polybutadiene combine low molecular weights characteristics with good crosslinking properties. These types of resins tend to conduct heat better because of enhanced micro and macro ordering of their sub-structure which may lead to enhanced conduction of heat as a result of improved phonon transport. The better the phonon transport, the better the heat transfer.

[0041] When the high thermal conductivity fillers of the present invention are mixed with resins they form a continuous product, in that there is no interface between the resins and the fillers. In some cases, covalent bonds are formed between the fillers and the resin. However, continuous is somewhat subjective and depends on the scale to which the observer is using. On the macro-scale the product is continuous, but on the nano-scale there can still be distinct phases between the fillers and the resin network. Therefore, when referring high thermal conductivity fillers mixing with the resin, they form a continuous organic-inorganic composite, on the macro-scale, while on the micro-scale the same mixture can be referred to as a hybrid.

[0042] As mentioned, filled resin may be used in the electrical generator field without the tapes to fulfill electrical

insulation applications in the rotating and static electrical equipment components. The use of high thermal conductivity materials in a generator is multiple. Within the stator coil there are component materials other than the groundwall which must have high thermal conductivity to optimize the design. Likewise other components associated with the coils to maximize heat removal. Improvements to stator design dictate that improvements be made to rotor design so that generator efficiency can be maximized.

[0043] It is important that the interface between the various inorganic and organic components is made to be chemically and physically intimate to ensure a high degree of physical continuity between the different phases and to provide interfaces which are mechanically strong and not prone to failure. This is especially important during the operation of the electrical insulation embodiments discussed, such as the electrical insulation systems for both high and low voltage applications. An enhanced interface integrity would enable an enhanced power rating, higher voltage stressing, reduced insulation thickness and high heat transfer.

[0044] Surface treatments to fillers introduce a variety of surface functional groups that are capable of compatibilizing inorganic surface of the filler with the organic resin matrix. Typical surface treatment is to introduce surface functional groups is to treat a surface physically (e.g. silane solution on metal oxides) to give reactive groups. The interface between the particle surface, such as the HTC filler, surface and the silane layer would only be held by physical bonding, such as polar attraction and H-bonds. Although the silane surface could react with a resin that it is mixed in, there is no true chemical bond formed between the particle surface and the silane, i.e. essentially unreactive coupling. Even if the substrate surface was rich in OH groups, such as hydrated Alumina, that could potentially react with the silane, it is unlikely that significant chemical bonds will form. In the case of the HTC fillers discussed herein, there would be virtually no chemical bond formation.

[0045] In order to obtain functional groups that are chemically attached to the HTC material (particle) surface, the present invention uses reactive grafting. Reactive grafting occurs when the functional groups are chemically attached to the nanoparticle surface by a reactive process, such as by chemical reaction. Other processes include those that are plasma and radiation (e.g. UV, gamma, electron, etc.) driven, which require appropriate environments and may be done in a multi-stage process. In this manner, a strong chemical bond is produced between the nanoparticle surface and the functional group attached (e.g., OH, COOH, NH₂ and vinyl); i.e. reactive coupling. This would be the definition of a reactive functional graft, i.e., the chemical attachment of a functional group directly onto the particle surface. These reactive grafting procedures are high energy compared to the physical bonding of the prior art, and use, for example, non-equilibrium plasma methods, chemical vapor and physical vapor deposition, sputter ion plating, laser beams, electron and ion beam evaporation methods to chemically modify the surfaces of the more inert surfaces of the HTC material, producing chemically attached functional species (e.g. OH, COOH, NH₂, vinyl) which are then reacted with resin to produce a continuous HTC matrix.

[0046] Specific examples of this include treating boron nitride (BN) nanoparticles with an electron beam in the presence of water vapor to produce reactive N—OH groups that subsequently can be reacted with an LCT epoxy resin. The

nitrogen of the reactive group comes directly from the boron nitride particle and remains linked to the particle. Therefore the formulation is:

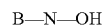

where the boron is part of the larger nanoparticle. The hydroxyl (OH) group can then react directly with the resin or even another intermediate function group. Another example is modifying the surface of Aluminum Nitride nanoparticles in a hydrogen-rich vapor to produce surface NH₂ reactive groups which can subsequently be reacted with a LCT epoxy or polyimide resin. Still another specific example uses a plasma polymerization procedure, with Silicon Carbide nanoparticles, to produce surface grafted vinyl groups which can then be reacted with a vinyl monomer or a polybutadiene resin.

[0047] In a distinct aspect, the present invention involves a less energetic reactive grafting procedure involving wet chemical techniques of selective reactions between an HTC material and a surface functional group produce homogenous LCT-epoxy polymers with oligomers containing grafted nano-sized HTC-materials.

[0048] In one of these distinct aspects the present invention relates to a method of making homogenous LCT-epoxy polymers with oligomers containing grafted nano-sized HTC-materials (HTC-oligomers). The dielectric strength of these polymers is at least 1.2 kV/mil. The steps of making these polymers include grafting at least one functionalized organic group onto a nano-sized HTC-material to produce an HTC-oligomer. The HTC-oligomer is then reacted with at least one LCT-epoxy resin under conditions sufficient to form a uniform dispersion and an essentially complete co-reactivity of the HTC-oligomer with the LCT-epoxy resin(s). This reaction forms an intermediate resin-like mixture that is then cured to produce the homogenous LCT-epoxy polymers with HTC-oligomers.

[0049] In this aspect of the invention, the amount of the HTC-oligomer to the amount LCT-epoxy resin comprises a ratio of between 1:4 and 3:1 by weight. In a more particular embodiment of the wet chemical grafting technique the HTC-oligomer portions of the homogenous LCT-epoxy polymers with HTC-oligomers is 20-50% by weight.

[0050] Though there are a variety of methods for preparing LCT-epoxy resins, a particular method is warming the sample at approximately 60° C. until the LCT-epoxy resin is clear. Likewise, when mixing the LCT-epoxy resin and the HTC-oligomer, one method is to warm to approximately 60° C. until clear. The nano-sized HTC-material can be one or more of alumina, silica and a metal oxide. In a more particular embodiment of the wet chemical grafting technique the metal oxide is magnesium oxide. Other appropriate HTC-materials will be apparent to one of ordinary skill in the art.

[0051] In another embodiment of the wet chemical grafting technique, the grafting the functionalized organic group(s) onto the nano-sized HTC-material is performed by either a silane grafting or a free radical grafting. In a more particular embodiment of the wet chemical grafting technique, the silane grafting involves reactants chosen from 4-trimethoxysilyl tetra-hydrophthalic anhydride (TSPA) and 3-methacryloxypropyl trimethoxy silane (MOTPS). In another particular embodiment of the wet chemical grafting technique, the free radical grafting involves the reactant ceric ammonium nitrate.

[0052] In another embodiment of the wet chemical grafting technique, the method further comprises mixing at least one

anhydriding agent with either or both of the LCT-epoxy resin (s) and the HTC-oligomers, where the homogenous LCT-epoxy polymers with HTC-oligomers are a homogenous LCT-epoxy anhydride polymers with HTC-oligomers.

[0053] In a particular embodiment of the wet chemical grafting technique the anhydriding agent is taken from the group consisting of 1-methylhexahydrophthalic anhydride and 1-methyltetrahydrophthalic anhydride. In another particular embodiment of the wet chemical grafting technique the anhydriding agent is approximately 20-40% by weight of the homogenous LCT-epoxy anhydride polymers with HTC-oligomers. In another embodiment of the wet chemical grafting technique, the method further comprises mixing at least one vinyl agent with either or both of the LCT-epoxy resin(s) and the HTC-oligomers, where the homogenous LCT-epoxy polymers with HTC-oligomers are a homogenous LCT-epoxy vinyl polymers with HTC-oligomers.

[0054] In another aspect, the present invention provides for a method of making homogenous LCT-epoxy polymers with HTC-oligomers that have a dielectric strength of at least 1.2 kV/mil, which is coated on at least one electrical insulator. This method involves the steps of grafting at least one functionalized organic group onto a nano-sized HTC-material to produce HTC-oligomers. The HTC-oligomers are then reacted with at least one LCT-epoxy resin where an intermediate resin-like mixture is formed. This mixture is then warmed under sufficient conditions to form a uniform dispersion and an essentially complete co-reactivity of the HTC-oligomers with the LCT-epoxy resin(s). The mixture is then impregnated onto the electrical insulator and cured to produce the homogenous LCT-epoxy polymers with HTC-oligomers. In this aspect the amount of the HTC-oligomers to the at least one LCT-epoxy resin comprises a ratio of between 1:4 and 3:1 by weight.

[0055] In one embodiment of the wet chemical grafting technique the method further comprises mixing at least one anhydriding agent with one or both of the LCT-epoxy resin(s) and the HTC-oligomers, where the homogenous LCT-epoxy polymers with HTC-oligomers are a homogenous LCT-epoxy anhydride polymers with HTC-oligomers. In another embodiment of the wet chemical grafting technique the method further comprises mixing at least one vinyl agent with one or both of the at least one LCT-epoxy resin(s) and the HTC-oligomers, where the homogenous LCT-epoxy polymers with HTC-oligomers are a homogenous LCT-epoxy vinyl polymers with HTC-oligomers.

[0056] In another aspect the present invention provides homogenous LCT-epoxy polymers with HTC-oligomers. This comprises at least one HTC-oligomer sub-structure that contains at least one nano-sized HTC-material grafted thereto and at least one LCT-epoxy sub-structure, where the HTC-oligomer sub-structure is organically bonded to the LCT-epoxy substructure. The thermal conductivity in the transverse direction is at least 0.50 W/mK and in the thickness direction is at least 0.99 W/mK in an environment of 25° C. The homogenous LCT-epoxy polymers with HTC-oligomers has a dielectric strength of at least 1.2 kV/mil, and is substantially free of particle wetting and micro-void formation. Further, approximately 20-75% by weight of the homogenous LCT-epoxy polymers with HTC-oligomers is the HTC-oligomer sub-structure.

[0057] Either the homogenous LCT-epoxy polymers with HTC-oligomers or the homogenous LCT-epoxy anhydride/vinyl polymers with HTC-oligomers may be produced as a

coating on insulative materials, such as a mica/glass insulating tape. HTC-oligomers as used herein refers to any oligomer with grafted nano-sized high thermal conductivity (HTC) material, according to the present invention.

[0058] Though there is no intention to be limited to a specific type of HTC-oligomer, or a specific method of synthesizing HTC-oligomers for the purposes of reacting with LCT-epoxy resins, particular nano-sized HTC-materials used may be alumina, silica, and metal oxides, including magnesium oxide and zinc oxide. Furthermore, these materials may be treated in a variety of different ways to produce even more variation on different kinds of HTC-oligomers. Examples of these include metal (or alumina or silica) oxide HTC-oligomers with the basic structure of:

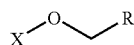

where X represents the HTC-material, and R represents an organic functional group.

[0059] As mentioned, the HTC-materials may be chemically grafted with a polymer structure by a variety of methods to produce the multitude of HTC-oligomers possible. A particular example of this is free radical grafting, where a reactant such as ceric ammonium nitrate may be used. Another particular example is silane grafting. In this example reactants used to produce functional groups include 4-trimethoxysilyl tetra-hydrophthalic anhydride (TSPA) and 3-methacryloxypropyl trimethoxy silane (MOTPS). If these reactants are used, an additional silica group, beyond what may be represented in the X group, will be present:

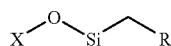

An alumina X group with a TSPA functional group would therefore be:

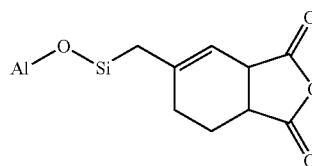

In all cases, the functional group, R, is then used to react with a given substance to produce a desired product.

[0060] In one embodiment of the wet chemical grafting technique the functional group reacts with the epoxy group of an LCT-epoxy resin to produce an LCT-epoxy with HTC-oligomers. However, before, concurrently or even after reacting the functional group with the LCT-epoxy group, the functional group may also react with other substance to improve the reaction with the LCT-epoxy and/or the final polymer structure. For example, an anhydride or a vinyl group or both may be added with the LCT-epoxy resin, in the producing of the HTC-oligomers, or when reacting the HTC-oligomer with the LCT-epoxy resin. In such a reaction, the final product would be an LCT-epoxy anhydride polymer with HTC-oligomers or an LCT-epoxy vinyl polymer with HTC-oligomers

or even an LCT-epoxy anhydride-vinyl polymer with HTC-oligomers. It should be noted that though the HTC-oligomer may be formed using an anhydride containing reagent, the term anhydride used herein describes resins and polymers of the present invention that have had an additional anhydride reagent added.

[0061] The following is a particular method of making a suitable HTC-oligomer as used in the synthesis of homogeneous LCT-epoxy polymers with oligomers containing grafted nano-sized HTC-materials (LOT-epoxy polymers with HTC-oligomers):

Graft polymerization reactions were carried out in a round-bottomed, three-neck flask fitted with a stirrer, a gas inlet tube and a thermometer. 2.0 g of nano-size magnesium oxide was dispersed in 25 ml. of distilled water, and the grafting reaction was carried out under nitrogen by bubbling the gas through the reaction mixture. The required amount of initiator solution was then added (0.55 g of ceric ammonium nitrate dissolved in 10 ml of 1N nitric acid, followed by 6.0 ml of methyl methacrylate. The reaction was allowed to proceed for 3 hours at 40° C. The grafted product was extracted in a soxhlet extractor to remove the polymer.

[0062] Though the below examples use powdered HTC-oligomers, it will be apparent to one of ordinary skill in the art that the HTC-materials may be delivered to the reaction in other forms, such as in solution.

[0063] The synthesis of LCT-epoxy polymers with HTC-oligomers according to the present invention may similarly be done by a variety of methods that will be apparent to one of ordinary skill in the art after review of the procedures contained herein. A particular method, however, comprises:

Alumina-grafted-TSPA-oligomer (HTC-oligomer) (2.5 g) was ground to a fine powder in a porcelain mortar. LCT-epoxy resin RSS-1407 (4.0 g) was warmed to 60° C. in a small glass jar. The HTC-oligomer powder was added to the resin and the mixture stirred for approximately 30 min. until the solution was clear. 0.1 g of zinc naphthenate was added as a cure catalyst and mixed over an additional 5 min. The liquid was then poured into a small aluminum dish and placed in an oven at 150° C. for four hours to cure.

[0064] This reaction may be summarized as follows:

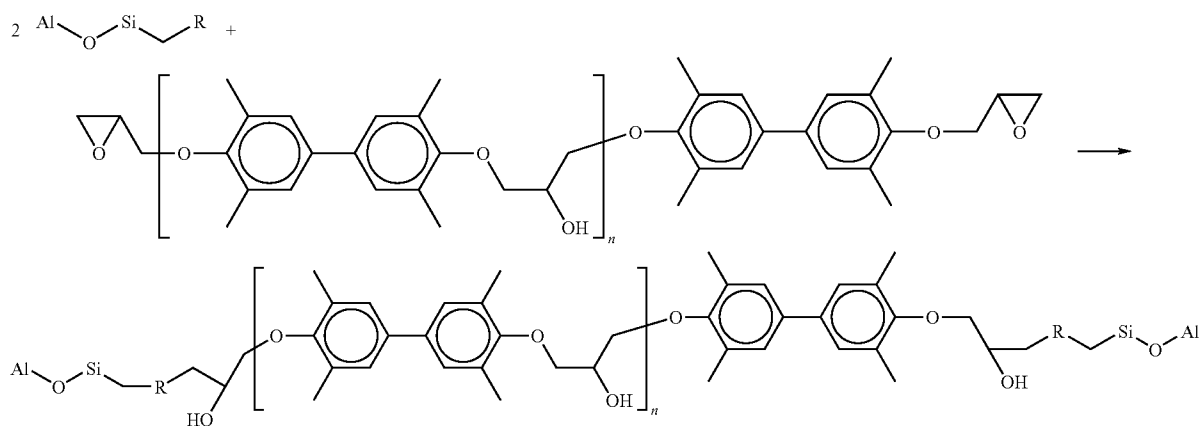

[0065] The two HTC-oligomers with an R functional group are reacted with a biphenol LCT-epoxy chain that contains n repeating biphenol units. The result is an LCT-epoxy polymer

with cross-linked HTC-oligomers. The HTC-oligomers particles become organically bonded to the LCT-epoxy chain. Though this example uses biphenol LCT-epoxy, this reaction could be performed with any variety of LCT, alone or in combination. Examples of other LCTs can be found in U.S. Pat. No. 5,904,984, which is incorporated herein by reference.

[0066] The synthesis of the LCT-epoxy anhydride polymers with HTC-oligomers by this example produces polymers with approximately 38% by weight HTC-oligomer. The remaining percentage is primarily the LCT-epoxies with a small amount of accelerants and other materials. Though this is one embodiment of the wet chemical grafting technique of the present invention, the HTC-oligomer content may be anywhere from approximately 20-75% by weight. With a particular embodiment of the wet chemical grafting technique being from 30-55% by weight and an even more specific embodiment of the wet chemical grafting technique of 35-50% by weight.

[0067] Similar to the synthesis of the LCT-epoxy polymers with HTC-oligomers, an example of the synthesis of an LCT-epoxy-anhydride polymers with HTC-oligomers comprises: Biphenol LCT-epoxy resin RSS-1407 (4.0 g) was added to 1-methylHexahydrophthalic anhydride (4.0 g) stirring in a small glass jar warmed to 60° C. on a hot plate. After the solution was clear, an alumina-grafted-TSPA-oligomer (HTC-oligomer) (3.0 g) was added and the solution stirred further at 60° C. until the solution was again clear. 0.1 g of zinc naphthenate was added as a cure accelerator and mixed over an additional 5 min. The liquid was then poured into a small aluminum dish and placed in an oven at 150° C. for four hours to cure.

[0068] The use of the anhydride components adds additional reactivity to this reaction, aiding the HTC-oligomer's co-reactivity with the LCT-epoxies. Further, the resulting polymers are more fluid, with improved insulative properties. In this example the anhydrides make up approximately 36% by weight of the final LCT-epoxy-anhydride polymers. Though this is one embodiment of the wet chemical grafting technique of the present invention, the anhydride content may

be anywhere from approximately 20-40% by weight. In this example, the overall percentage of HTC-oligomers is lower than that of the above example. This might not always be the

case, and the addition of anhydride might not reduce the overall percentage of HTC-materials in the resulting polymers.

[0069] In both of the above examples, a LCT-epoxy polymer with HTC-oligomers may also contain a vinyl group. A variety of methods for including a vinyl group would be apparent to one of ordinary skill in the art. However, a particular method of making an LCT-epoxy vinyl polymer with HTC-oligomers, or an LCT-epoxy anhydride-vinyl polymer with HTC-oligomers, would be to follow the above examples, but begin with a MOTPS-oligomer instead of a TSPA-oligomer. In following with the above examples, when the cure accelerator is added, add a vinyl containing reactant, such as the di-functional monomer, p-vinylphenylglycidylether (which, in keeping with the above sample sized, would be approximately 1.0 g).

[0070] The addition of a vinyl group to the reaction is dependent upon what types of reagents are being used and under what conditions. For example, some LCT-epoxy resins contain styrene. Therefore the vinyl group would allow for a more complete reaction of the LCT-epoxy resin and the HTC-oligomers, therefore producing a better and more homogeneous polymer. If a vinyl group is added, its approximate percentage in the final polymer will 4-16% by weight.

[0071] One embodiment of the present invention discussed above adds high thermal conductivity (HTC) materials to resins to improve the thermal conductivity of the resins. In some embodiments the other physical properties of the resins are reduced in a trade-off with higher thermal conductivity, but in other embodiments, some of the other physical properties will not be significantly affected, and in some particular embodiments these other properties will be improved. In particular embodiments, the HTC materials are added to resins, such as LCT epoxy, that have ordered sub-structures. When added to these types of resins, the amount of HTC material used can be reduced versus use in resins without ordered sub-structures.

[0072] The HTC materials loaded into the resins are of a variety of substances that can be added so that they may physically and/or chemically interact with or react with the resins to improve thermal conductivity. In one embodiment, the HTC materials are dendrimers, and in another embodiment they are nano or micro inorganic fillers having a defined size or shape including high aspect ratio particles with aspect ratios (ratio mean lateral dimension to mean longitudinal dimension) of 3 to 100 or more, with a more particular range of 10-50.

[0073] In a related embodiment, the HTC materials may have a defined size and shape distribution. In both cases the concentration and relative concentration of the filler particles is chosen to enable a bulk connecting (or so-called percolation) structure to be achieved which confers high thermal conductivity with and without volume filling to achieve a structurally stable discrete two phase composite with enhanced thermal conductivity. In another related embodiment, the orientation of the HTC materials increases thermal conductivity. In still another embodiment, the surface coating of the HTC materials enhances phonon transport. These embodiments may stand apart from other embodiments, or be integrally related. For example, dendrimers are combined with other types of highly structured materials such as thermoset and thermoplastic materials. They are uniformly distributed through a resin matrix such that the HTC materials reduce phonon scattering and provide micro-scale bridges for

phonons to produce good thermally conducting interfaces between the HTC materials. The highly structured materials are aligned so that thermal conductivity is increased along a single direction or directions to produce either localized or bulk anisotropic electrically insulating materials. In another embodiment HTC is achieved by surface coating of lower thermal conductivity fillers with metal oxides, carbides or nitrides and mixed systems having high thermal conductivity which are physically or chemically attached to fillers having defined bulk properties, such attachment being achieved by processes such as chemical vapour deposition and physical vapour deposition and also by plasma treatment.

[0074] In further related embodiments, the HTC materials form essentially homogenous mixtures with the resins, essentially free of undesired microscopic interfaces, variable particle wetting and micro void formation. These homogeneous materials form a continuous-phase material which are non-discrete at length scales shorter than either the phonon wavelength or phonon mean free path in conventional electrical insulating materials. In some embodiments, intentional interfaces can be placed in the resin structure so as to control dielectric breakdown. In insulating materials, dielectric breakdown will occur given the right conditions. By controlling the nature and spatial distribution of the interfaces in two-phase system, dielectric breakdown strength and long term electrical endurance can be enhanced. Increases in dielectric strength will take place in part because of increased densification, the removal of micro voids and a higher level of internal mechanical compression strength.

[0075] Resins of the present invention may be used for impregnation of other composite constructions such as a mica tape and glass and polyester tape. In addition to the standard mica (Muscovite, Phlogopite) that is typically used for electrical insulation there is also Biotite mica as well as several other mica-like Alumino-Silicate materials such as Kaolinite, Halloysite, Montmorillonite and Chlorite. Montmorillonite has lattices in its structure which can be readily intercalated with polymer resins, metal cations and nano particles to give high dielectric strength composites.

[0076] In other embodiments, the present invention is used as a continuous coating on surfaces where insulation is desired; note that "continuous coating" is a description of a macro-scale application. In a continuous coating, the resin forms a coating on materials without the need for a tape or other substrate. When used with a substrate, the HTC materials can be combined with the resin by a variety of different methods. For example, they can be added prior to the resin being added to the substrate, or the HTC materials can be added to the substrate before the resin is impregnated thereon, or the resin can be added first, followed by the HTC material and then an additional impregnation of resin. Other fabrication and process methods will be apparent to one of ordinary skill in the art.

[0077] In one embodiment the present invention as discussed above uses novel organic-inorganic materials which offer higher thermal conductivity and also maintain or enhance other key properties and performance characteristics. Such materials have applications in other high voltage and low voltage electrical insulation situations where high thermal conductivity confers advantage in terms of enhanced power rating, reduced insulation thickness, more compact electrical designs and high heat transfer. The present invention adds nano, meso, and micro inorganic HTC-materials such as alumina, magnesium oxide, silicon carbide, boron

nitride, aluminium nitride, zinc oxide and diamond, as well as others, to give higher thermal conductivity. These materials can have a variety of crystallographic and morphological forms and they may be processed with the matrix materials either directly or via a solvent which acts as a carrier liquid. The solvent mixture may be used to mix the HTC-materials into the matrix to various substrates such as mica-tape. In contrast, molecular hybrid materials which form another embodiment of the present invention, do not contain discrete interfaces, and have the advantages conferred by an inorganic phase within an organic. These materials may also confer enhancement to other physical properties such as thermal stability, tensile strength, flexural strength, and impact strength, variable frequency and temperature dependant mechanical moduli and loss and general viscoelastic response, etc.

[0078] In another embodiment, the present invention as discussed above comprises discrete organic-dendrimer composites in which the organic-inorganic interface is non-discrete with a dendrimer core-shell structure. Dendrimers are a class of three-dimensional nanoscale, core-shell structures that build on a central core. The core may be of an organic or inorganic material. By building on a central core, the dendrimers are formed by a sequential addition of concentric shells. The shells comprise branched molecular groups, and each branched shell is referred to as a generation. Typically, the number of generations used is from 1-10, and the number of molecular groups in the outer shell increase exponentially with the generation. The composition of the molecular groups can be precisely synthesized and the outer groupings may be reactive functional groups. Dendrimers are capable of linking with a resin matrix, as well as with each other. Therefore, they may be added to a resin as an HTC material, or, in other embodiments, may form the matrix themselves without being added to traditional resins.

[0079] The molecular groups can be chosen for their ability to react, either with each other or with a resin. However, in other embodiments, the core structure of the dendrimers will be selected for their own ability to aid in thermal conductivity; for example, metal oxides as discussed below.

[0080] Generally, the larger the dendrimer, the greater its ability to function as a phonon transport element. However, its ability to permeate the material and its percolation potential can be adversely affected by its size so optimal sizes are sought to achieve the balance of structure and properties required. Like other HTC materials, solvents can be added to the dendrimers so as to aid in their impregnation of a substrate, such as a mica or a glass tape. In many embodiments, dendrimers will be used with a variety of generations with a variety of different molecular groups.

[0081] Commercially available organic Dendrimer polymers include Polyamido-amine Dendrimers (PAMAM) and Polypropylene-imine Dendrimers (PPI) and PAMAM-OS which is a dendrimer with a PAMAM interior structure and organo-silicon exterior. The former two are available from Aldrich Chemical™ and the last one from Dow-Corning™.

[0082] Similar requirements exist for inorganic-organic dendrimers which may be reacted together or with matrix polymers or reactive resins to form a single material. In this case the surface of the dendrimer could contain reactive groups similar to those specified above which will either allow dendrimer-dendrimer, dendrimer-organic, dendrimer-hybrid, and dendrimer-HTC matrix reactions to occur. In this case the dendrimer will have an inorganic core and an organic

shell, or vice-versa containing either organic or inorganic reactive groups or ligands of interest. It is therefore also possible to have an organic core with an inorganic shell which also contains reactive groups such as hydroxyl, silanol, vinyl-silane, epoxy-silane and other groupings which can participate in inorganic reactions similar to those involved in common sol-gel chemistries.

[0083] In all cases phonon transport is enhanced and phonon scattering reduced by ensuring the length scales of the structural elements are shorter than or commensurate with the phonon distribution responsible for thermal transport. Larger HTC particulate materials can actually increase phonon transport in their own right, however, smaller HTC materials can alter the nature of the resin matrix, thereby affect a change on the phonon scattering. This may be further assisted by using nano-particles whose matrices are known to exhibit high thermal conductivity and to ensure that the particle size and interfacial characteristics are sufficient to sustain this effect and also to satisfy the length scale requirements for reduced phonon scattering. It is also necessary to consider the choice of structures that are more highly ordered including reacted dendrimer lattices having both short and longer range periodicity and ladder or ordered network structures that may be formed from matrices such as liquid crystal epoxy resins and polybutadienes. A resin matrix of the prior art will have a maximum thermal conductivity of about 0.15 W/mK. The present invention provides resins with a thermal conductivity of 0.5 to 5 W/mK and even greater.

[0084] Continuous organic-inorganic hybrids may be formed by incorporating inorganic nano-particles in linear or crosslinked polymers and thermosetting resins in which nano-particles dimensions are of the order of or less than the polymer or network segmental length (typically 1 to 50 nm). This would include, but is not exclusive to three routes or mechanisms by which this can occur (i) side chain grafting, (ii) inclusive grafting e.g. between two polymer chain ends, (iii) cross-link grafting involving at least two and typically several polymer molecules. These inorganic nano-particles will contain reactive surfaces to form intimate covalently bonded hybrid organic-inorganic homogeneous materials. These nano-particles may be metal oxides, metal nitrides, and metal carbides, as well as some non-metal oxides, nitrides and carbides. For example, alumina, magnesium oxide and zinc oxide and other metal oxides, boron nitride and aluminum nitride and other metal nitrides, silicon carbide and other carbides, diamond of natural or synthetic origin, and any of the various physical forms of each type and other metal carbides and hybrid stoichiometric and non-stoichiometric mixed oxides, nitrides and carbides. More specific examples of these include Al_2O_3 , AlN, MgO, ZnO, BeO, BN, Si_3N_4 , SiC and SiO_2 with mixed stoichiometric and non-stoichiometric combinations. Further, these nano-particles will be surface treated to introduce a variety of surface functional groups which are capable of participating in reactions with the host organic polymer or network. It is also possible to coat non-HTC materials, such as silica and other bulk filler materials, with an HTC material. This may be an option when more expensive HTC materials are used.

[0085] The volume percentage of the HTC materials in the resin may be up to approximately 60% or more by volume, and more particularly up to approximately 35% by volume. Higher volume filling tends to give higher structural stability to a matrix. However, with control of the size and shape distribution, degree of particle association and alignment the

HTC materials can occupy as little as 1% by volume or less. Although, for structural stability reasons, it might be useful to add an amount greater than the minimum needed for percolation to occur. Therefore the resin can withstand physical strains and deformation without damaging the percolation structure and the HTC characteristics.

[0086] The addition of surface functional groups may include hydroxyl, carboxylic, amine, epoxide, silane or vinyl groups which will be available for chemical reaction with the host organic polymer or network forming resin system. These functional groups may be naturally present on the surface of inorganic fillers or they may be applied using wet chemical methods, non-equilibrium plasma deposition including plasma polymerization, chemical vapour and physical vapour deposition, sputter ion plating and electron and ion beam evaporation methods. The matrix polymer or reactive resin may be any system which is compatible with the nano-particles and, if required, is able to react with the reactive groups introduced at the nano-particle surface. These may be epoxy, polyimide epoxy, liquid crystal epoxy, cyanate-ester and other low molecular weight polymers and resins with a variety of crosslinking agents.

[0087] In the case of non-discrete organic-inorganic hybrids it is possible to use sol-gel chemistry to form a continuous molecular alloy. In this case sol-gel chemistries involving aqueous and non-aqueous reactions may be considered.

[0088] The products of the present invention exhibit higher thermal conductivity than conventional electrically insulating materials and may be used as bonding resins in mica-glass tape constructions, as unreacted vacuum-pressure impregnation resins for conventional mica tape constructions and as stand alone materials to fulfill electrical insulation applications in rotating and static electrical power plant and in both high and low voltage electrical and electronic equipment, components and products. Products of the present invention may be combined with each other, as well as HTC-material, and other materials, of the prior art.

[0089] Micro and nano HTC particles may be selected on their ability to self aggregate into desired structural forms such as filaments and branched dendrites. Particles may be selected for their ability to self-assemble naturally, though this process may also be modified by external forces such as an electric field, magnetic field, sonics, ultra-sonics, pH control, use of surfactants and other methods to affect a change to the particle surface charge state, including charge distribution, of the particle. In a particular embodiment, particles such as boron nitride, aluminum nitride, diamond are made to self assemble into desired shapes. In this manner, the desired aggregation structures can be made from highly thermally conductive materials at the outset or assembled during incorporation into the host matrix.

[0090] In many embodiments, the size and shape of the HTC-materials are varied within the same use. Ranges of size and shape are used in the same product. A variety of long and shorter variable aspect ratio HTC-materials will enhance the thermal conductivity of a resin matrix, as well as potentially provide enhanced physical properties and performance. One aspect that should be observed, however, is that the particle length does not get so long as to cause bridging between layers of substrate/insulation. Also, a variety of shapes and length will improve the percolation stability of the HTC-materials by providing a more uniform volume filling and packing density, resulting in a more homogeneous matrix.

When mixing size and shapes, in one embodiment the longer particles are more rod-shaped, while the smaller particles are more spheroidal, platelet or discoid and even cuboids. For example a resin containing HTC-materials could contain about 55-65% by volume 10-50 nm diameter spheroids and about 15-25% by volume 10-50 μm length rods, with 10-30% volume resin.

[0091] In another embodiment the present invention as discussed provides for new electrical insulation materials based on organic-inorganic composites. The thermal conductivity is optimized without detrimentally affecting other insulation properties such as dielectric properties (permittivity and dielectric loss), electrical conductivity, electric strength and voltage endurance, thermal stability, tensile modulus, flexural modulus, impact strength and thermal endurance in addition to other factors such as viscoelastic characteristics and coefficient of thermal expansion, and overall insulation. Organic and inorganic phases are constructed and are selected to achieve an appropriate balance of properties and performance.

[0092] In one embodiment the surface coating of nano, mesa and micro inorganic fillers having the desired shape and size distribution and the selected surface characteristics and bulk filler properties are complimentary to each other. This enables the percolation structure of the filler phase in the organic host and the interconnection properties to be controlled independently while maintaining required bulk properties. In addition organic and inorganic coatings, as singular or secondary coatings may be used to ensure compatibilisation of the particle surfaces with the organic matrix and allow chemical reactions to occur with the host organic matrix.

[0093] In regards to shape, the present invention utilizes individual particle shapes tending towards natural rods and platelets for enhanced percolation, with rods being the most preferred embodiment including synthetically processed materials in addition to those naturally formed. A rod is defined as a particle with a mean aspect ratio of approximately 5 or greater, with particular embodiments of 10 or greater, though with more particular embodiments of no greater than 100. In one embodiment, the axial length of the rods is approximately in the range 10 nm to 100 microns. Smaller rods will percolate a resin matrix better, and have less adverse effect on the viscosity of the resin.

[0094] Many micro and nano particles form spheroidal and discoid shapes, which have reduced ability to distribute evenly under certain conditions and so may lead to aggregated filamentary structures that reduce the concentration at which percolation occurs. By increasing the percolation, the thermal properties of the resin can be increased, or alternately, the amount of HTC material that needs to be added to the resin can be reduced. Also, the enhanced percolation results in a more even distribution of the HTC materials within the resin rather than agglomeration which is to be avoided, creating a more homogenous product that is less likely to have undesired interfaces, incomplete particle wetting and micro-void formation. Likewise aggregated filamentary or dendritic structures, rather than globular (dense) aggregates or agglomerates, formed from higher aspect ratio particles confer enhanced thermal conductivity.

[0095] Additionally, fluid flow fields and electric and magnetic fields can be applied to the HTC materials to distribute and structurally organize them inside of the epoxy resin. By using alternating or static electric fields, the rod and platelet shapes can be aligned on a micro-scale. This creates a mate-

rial that has different thermal properties in different directions. The creation of an electric field may be accomplished by a variety of techniques known in the art, such as by attaching electrodes across an insulated electrical conductor or by use of a conductor in the centre of a material or the insulation system.

[0096] Organic surface coatings, and inorganic surface coatings such as, metal-oxide, -nitride, -carbide and mixed systems may be generated which, when combined with the selected particle size and shape distribution, provide a defined percolation structure with control of the bulk thermal and electrical conductivity of the insulation system while the particle permittivity may be chosen to control the permittivity of the system. Another type of coating is micro-particulate and nano-particulate diamond coatings and of natural or synthetic origin. In poly-crystalline and mono-crystalline nano-particulate form, the particles may associate with the surface of a carrier particle, eg silica. Silica by itself is not a strong thermally conducting material, but with the addition of a surface coating it becomes more of a higher thermal conductivity material. Silica and other such materials, however, have beneficial properties such as being readily formed into rod-shaped particles, as discussed above. In this manner, various HTC properties can be combined into one product. These coatings may also have application to mica tape structures, including both the mica and the glass components, with or without resin impregnation.

[0097] Reactive surface functional groups may be formed from surface groups intrinsic to the inorganic coating or may be achieved by applying additional organic coatings both of which may include hydroxyl, carboxylic, amine, epoxide, silane, vinyl and other groups which will be available for chemical reaction with the host organic matrix. These single or multiple surface coatings and the surface functional groups may be applied using wet chemical methods, non-equilibrium plasma methods including plasma polymerization and chemical vapour and physical vapour deposition, sputter ion plating and electron and ion beam evaporation methods.

[0098] In another embodiment the present invention provides for new electrical insulation systems based on organic-inorganic composites. The interface between the various inorganic and organic components is made to be chemically and physically intimate to ensure a high degree of physical continuity between the different phases and to provide interfaces which are mechanically strong and not prone to failure during the operation of the electrical insulation system in service in both high and low voltage applications. Such materials have applications in high voltage and low voltage electrical insulation situations where enhanced interfacial integrity would confer advantage in terms of enhanced power rating, higher voltage stressing of the insulation systems, reduced insulation thickness and would achieve high heat transfer.

[0099] A particular embodiment uses a variety of surface treatments, nano, meso and micro inorganic fillers, so as to introduce a variety of surface functional groups which are capable of compatibilizing the inorganic surface with respect to the organic matrix or to allow Chemical reactions to occur with the host organic matrix. These surface functional groups may include hydroxyl, carboxylic, amine, epoxide, silane or vinyl groups which will be available for chemical reaction with the host organic matrix. These functional groups may be applied using wet chemical methods, non-equilibrium

plasma methods, chemical vapour and physical vapour deposition, sputter ion plating and electron and ion beam evaporation methods.

[0100] In many embodiments, the surface treated materials may be used in bonding resins in mica-glass tape constructions, in unreacted vacuum-pressure impregnation (GVPI & VPI) resins for conventional mica tape constructions and in stand alone electrical insulation coatings or bulk materials to fulfill either electrically insulating or conducting applications in rotating and static electrical power plant and in both high and low voltage electrical equipment, components and products. Also, all chemical reactions should be the result of addition, and not condensation reactions so as to avoid volatile by-products.

[0101] Improvements in epoxy resins have recently been made by using liquid crystal polymers. By mixing an epoxy resin with a liquid crystal monomer or by incorporating a liquid crystalline mesogen into an epoxy resin molecule such as DGEBA, a liquid crystal thermoset (LCT) epoxy resin is produced that contains polymers or monomers that can be cross-linked to form ordered networks having significantly improved mechanical properties. See U.S. Pat. No. 5,904,984, which is incorporated herein by reference. A further benefit of LCTs is that they also have improved thermal conductivity over standard epoxy resins, and lower coefficient of thermal expansion (CTE) values as well.

[0102] What makes LCT epoxy resins even more appealing is that they are also better able to conduct heat than a standard epoxy resin. U.S. Pat. No. 6,261,481, which is incorporated herein by reference, teaches that LCT epoxy resins can be produced with a thermal conductivity greater than that of conventional epoxy resins. For example, a standard Bisphenol A epoxy is shown to have thermal conductivity values of 0.18 to 0.24 watts per meter degree Kelvin (W/mK) in both the transverse (plane) and thickness direction. By contrast, an LCT epoxy resin is shown to have a thermal conductivity value, when used in practical applications, of no more than 0.4 W/mK in the transverse direction and up to 0.9 W/mK in the thickness direction.

[0103] As used in reference to HTC materials being applied to paper, the term substrate refers to the host material that the insulating paper is formed from, while paper matrix refers to the more complete paper component made out of the substrate. These two terms may be used somewhat interchangeable when discussing this embodiment of the present invention. The increase of thermal conductivity should be accomplished without significantly impairing the electrical properties, such as dissipation factor, or the physical properties of the substrate, such as tensile strength and cohesive properties. The physical properties can even be improved in some embodiments, such as with surface coatings. In addition, in some embodiments the electrical resistivity of the host paper matrix can also be enhanced by the addition of HTC materials.

[0104] In addition to the standard mica (Muscovite, Phlogopite) that is typically used for electrical insulation there is also Biotite mica as well as several other Mica-like Alumino-Silicate materials such as Kaolinite, Halloysite, Montmorillonite and Chlorite. Montmorillonite has lattices in its structure which can be readily intercalated with HTC materials such as metal cations, organic compounds and monomers and polymers to give high dielectric strength composites.

[0105] Insulating papers are just one type of porous media that may be impregnated with the resin of the present inven-

tion. Many other materials and components made therefrom, in many industries, some of which are mentioned below, can use different types of porous media to impregnate the resin into. By way of examples there are glass fiber matrices or fabric, and polymer matrices or fabric, where the fabric might typically be cloth, matt, or felt. Circuit boards, which are glass fabric laminate, with planar lamination, will be one product which will benefit from the use of resins of the present invention.

[0106] Types of resin impregnation used with stator coils are known as VPI and GVPI. Tape is wrapped around the coil and then impregnated with low viscosity liquid insulation resin by vacuum-pressure impregnation (VPI). That process consists of evacuating a chamber containing the coil in order to remove air and moisture trapped in the mica tape, then introducing the insulation resin under pressure to impregnate the mica tape completely with resin thus eliminating voids, producing resinous insulation in a mica host. A compression of about 20% is particular to the VPI process in some embodiments. After this is completed, the coils are heated to cure the resin. The resin may contain an accelerator or the tape may have one in it. A variation of this, global VPI (GVPI) involves the process where dry insulated coils are wound, and then the whole stator is vacuum pressure impregnated rather than the individual coils. In the GVPI process, the coils are compressed prior to impregnation with the resin since the dry coils are inserted into their final position prior to impregnation. Although various compression methods have been discussed above, it is also possible to use the VPI/GVPI impregnating process for the actual compression stage of the present invention.

[0107] In a particular embodiment the present invention provides for continuous high thermal conductivity resin that comprises a host resin matrix and a high thermal conductivity filler. The high thermal conductivity filler forms a continuous organic-inorganic composite with the host resin matrix via surface functional groups that are grafted to the high thermal conductivity filler and forms covalent linkages with the host resin matrix. In a related embodiment the high thermal conductivity fillers are from 1-1000 nm in length, and have aspect ratios of between 3-100. More particular aspect ratios are between 10-50.

[0108] In another related embodiment the high thermal conductivity fillers are chosen from one or more of oxides, nitrides, carbides and diamond. While the surface functional groups are chosen from one or more of hydroxyl, carboxylic, amine, epoxide, silane and vinyl groups.

[0109] In another particular embodiment the present invention provides for continuous organic-inorganic resin with grafted functional groups bridging the organic-inorganic boundary that comprises a host resin network and inorganic high thermal conductivity fillers evenly dispersed in the host resin network and essentially completely co-reacted with the host resin network. The high thermal conductivity fillers have a length of between 1-1000 nm and aspect ratios of 10-50. The high thermal conductivity fillers are selected from one or more of oxides, nitrides, and carbides and the continuous organic-inorganic resin comprises a maximum of 60% by volume of the high thermal conductivity fillers, and in other embodiments a maximum of 35%. Particularly, the high thermal conductivity fillers have surface functional groups that are grafted to the high thermal conductivity fillers and the surface functional groups allow for the essentially complete co-reactivity with the host resin network.

[0110] In related embodiments the functional groups comprise one or more of hydroxyl, carboxylic, amine, epoxide, silane and vinyl groups. The one or more of oxides, nitrides, and carbides comprise Al_2O_3 , AlN, MgO, ZnO, BeO, BN, Si_3N_4 , SiC and SiO_2 with mixed stoichiometric and non-stoichiometric combinations. The host resin network includes epoxy, polyimide epoxy, polyimide, liquid crystal epoxy, polybutadiene, polyester and cyanate-ester. The continuous organic-inorganic resin further can also comprises a cross-linking agent, and the entire resin can be impregnated into a porous media.

[0111] In still another particular embodiment the present invention provides for method of making a high thermal conductivity resin that comprises supplying a host resin matrix and gathering a high thermal conductivity material, which is then surface treated with reactive surface functional groups in a high energy reaction such that the surface functional groups become grafted to the high thermal conductivity materials. Then mixing the treated high thermal conductivity materials with the host resin matrix such that the high thermal conductivity materials are substantially uniformly dispersed within the host resin matrix, and then reacting the surface functional groups that are grafted to the high thermal conductivity materials with the host resin matrix to produce the high thermal conductivity resin. The amount of the high thermal conductivity materials in the high thermal conductivity resin is a maximum of 60% by volume, and the high energy reaction produces bond strength of between approximately 200-500 kJ/mol.

[0112] In a related embodiment the method further comprises inserting a cross-linking agent. In other related embodiments the surface functional groups comprise one or more of hydroxyl, carboxylic, amine, epoxide, silane and vinyl groups, and the high energy reaction comprises one of non-equilibrium plasma radiation, chemical vapor and physical vapor deposition, sputter ion plating, laser beams, electron and ion beam evaporation.

[0113] In another specific embodiment the high thermal conductivity material comprises one or more of diamonds, AlN, BN, Si_3N_4 , and SiC. This group of HTC materials is particularly suited for forming bond strengths of between approximately 200-500 kJ/mol, since the internal bonds of the materials are very strong.

[0114] The present invention also provides for a mixture of some HTC particles that are grafted to the resin as discussed, as well as some HTC particles that are not grafted to the resin and therefore do not form a continuous bond with the host resin matrix. Grafted in this sense refers to grafted to the resin or surface treated ready to be grafted. Either or both of these classes of HTC particles may have additional surface treatments to influence other features such as how the particles interact with each other. As used herein, the grafted class of HTC particles are those that are directly bound to the resin host, while the non grafted class are not directly bound to the resin host; however either class can have a variety of surface treatments that perform other functions. The classes refer to the state of the particles as the resin is being used. Ultimately the resin will be cured, but in some specific embodiment discussed below, the non-grafted particles actually become grafted before or during curing.

[0115] Grafting, as discussed above, refers to the surface functional group of a material chemically bonding to the host resin or the network formed when that host resin reacts. In addition to this, physical grafting may also occur. Physical

grafting can be based upon ionic bonding, hydrogen bonding, or topographic anchoring. In all cases of grafting, the grafted tether, i.e. the attached resin molecule, will affect the properties of the grafted particle.

[0116] Grafted and non grafted particles will behave differently in the resin even if they are comprised of the same types of materials. Grafted particles will flow with the resin, even through small impregnation spaces if small enough. This can be used to increase the relative concentration of the grafted particles when the filled resin is impregnated into a tight network, such as those found in composite tapes. Conversely, if a resin impregnated network is compressed, the grafted particles will tend to flow out of the network with the resin, thereby increasing the concentration of non grafted particles. Therefore, by impregnation and compression, the ratios of the classes of HTC particles can be altered. This presents an opportunity to tailor different areas of a target, such as a composite tape, with different types of HTC materials. For example, the mica layer in a tape may benefit more from a specific kind of HTC material, such as BN, while the rest of the tape could be better suited to alumina. By making the grafted particles BN and the non grafted particles alumina, the ratios of the two types of HTC materials can be varied in the different composite tape components. However, as will be discussed, the particles with higher mechanical strength such as alumina, tend to be grafted, so that physical properties can be more greatly enhanced.

[0117] Furthermore, grafted particles are locked into the resin network, so these particles are more controlled by the resin. As a result the grafted particle reinforces the local structure, making the resin strong and more resistant to fracture than a matrix containing non-grafted particles will. Grafted particles are also less mobile and may create higher viscosity in the resin than non grafted particles. Non grafted particles, particularly if surface treated, flow better, and have a higher mobility and dispersion, but are more prone to aggregating. Grafted also have better contact with the resin, so thermal conductivity is on average better, although various types of surface treatments may make up for this difference.

[0118] The types of HTC materials used for both the grafted and non-grafted particles are similar and are discussed above. Both classes of particles may be chosen from any of the HTC materials mentioned above, with particular types already discussed. The different classes can be composed of the same or different types of material.

[0119] Although the focus on the particles thus far has been high thermal conductivity, particular embodiments for the grafted particles will actually use particles that produce higher mechanical strength and improved dielectric and electrical breakdown and endurance properties due to the effect of the particle on the resin. These particular types of grafted particles may be used to obtain a balance of properties in addition to achieving elevated thermal conductivity properties. Grafted particles naturally have a more intimate contact with the resin and thus more easily confer physical enhancements, but non grafted can also have similar effects.

[0120] In the cases where different types of HTC materials are used in the different classes of particles, different physical property enhancements can be achieved through each type. Materials that have readily available surface functional groups are easier to use as grafted particles. These include alumina, silica and the metal oxides discussed. Accordingly, nitrides, carbides and materials that do not have readily available surface functional groups more naturally fall into non

grafted uses. Special surface treatments may, however, enable the latter to function as grafted materials though.

[0121] Similarly to the composition of the particles, the sizes and shapes of the particles may be the same or different between classes. In regards to maintaining mobility and dispersion, the grafted particles should be generally larger, with average lengths of 100 nm or more, and non grafted generally smaller, 5-100 nm in length. The smaller particles will tend to produce a better packing density. Conversely to this, an embodiment that seeks greater structural strength can have long non grafted particles with smaller grafted particles in and amongst them to reinforce the resin. It should be noted that differences or similarities between the classes of particles does not mean that there has to be homogeneity within the classes themselves. Each class can be composed of a variety of different types and different shapes and sizes of HTC materials.

[0122] The ratio of grafted to non grafted particles will vary depending on the application. Further, the ratios will vary depending on the total amount of HTC particles added to the resin. The lower the total volume of HTC particles in the resin, the higher the minimum ratio of either class of particle needs to be. For example, a resin with a total HTC volume of 10% by volume should have a grafted to non grafted ratio of between 1:3 to 3:1. But a resin with 60% HTC materials could have a ratio of 1:20 to 20:1. In order to observe a net benefit from a given class of particle, the total amount of a class of particle in the resin should have a minimum of 1% by volume to have an appreciable effect, although the greater the aspect ratio of the particles, the greater the effect of the particles at low concentration. Ultimately, the ratios of grafted to non grafted are subject to multiple objective optimization of various physical variables.

[0123] Further, since non grafted particles will tend to cluster more than the grafted, a slightly higher ratio of non grafted particles by volume should be used in resin if the other physical properties discussed are not an overriding consideration. At the upper end of particle concentration, the resin will also support a larger amount of non grafted particles if they are relatively non inter-reactive.

[0124] Although a chemical graft may be formed from a surface functionalization of the particle, additional surface treatments may be done on both the grafted particles that are connected to the resin as well as the particles that are not grafted to the resin. The term surface treatment is a version of the term surface functionalization, which includes the variation that some surface treatments add unreactive groups. The additional surface treatments fulfill a variety of purposes and embodiments. In one case the surface treatments are used so that the HTC particles are well dispersed and do not aggregate. This can be accomplished by adding surface groups that either are generally unreactive or that do not react with one another. In a particular embodiment the two classes of HTC particles will have surface groups that are essentially unreactive with a class, but are reactive between the classes. In this case the non grafted particles become grafted to the resin through the grafted particles. The rate of this reaction can be slow so that penetration and diffusion characteristic differences can be realized before the classes of particles are joined.

[0125] Surface treatments of the HTC particles can provide benefits for the impregnated resin. Long chain surface treatments can facilitate better fracture toughness and viscoelasticity, whereas shorter chains or groups may favor higher mechanical modulus and higher thermal stability.

[0126] Other variations on surface treatment include having one class functionalized to self aggregate while the other class does not. For example, the grafted particles can be functionalized to self aggregate while the non grafted particle will be more uniformly dispersed. This causes a matrix with improved mechanical properties due to the non-grafted particles and increased thermal conductivity due to the grafted particles. Tailored "islands" of grafted particles in a "sea" of non grafted particles could produce block domain and layered structures having improved barrier performance such as to resist electrical breakdown and gas permeation while retaining high thermal conductivity. Anisotropic structures may also be produced providing materials having anisotropic physical properties.

[0127] Surface functionalizing the HTC materials can be done by processes known in the art, which involves grafting at least one functionalized organic group onto the HTC-material. The functionalized group can be a variety of reactive groups, including but not limited to OH, NH, or a carboxylic group. Examples of functionalizing include a silane grafting or a free radical grafting. In a more particular embodiment, the silane grafting involves reactants chosen from 4-trimethoxysilyl tetra-hydrophthalic anhydride (TSPA) and 3-methacryloxypropyl trimethoxy silane (MOTPS). In another particular embodiment, the free radical grafting involves the reactant ceric ammonium nitrate. Different surface treatments will be selected on the amount of reactivity desired between particles. If little or no reactivity is desired then groups such as a paraffinic chain or other chains with non-reactive end groups such as an ester can be added.

[0128] If it is desired to have a delayed interaction between the particles, as discussed above, the surface treatments/conditions may comprise a latent catalyst. Good examples of latent catalysts include Lewis Acid/Amine complexes (e.g., Boron Trifluoride/Mono-ethylamine) or Blocked Isocyanates where the blocking group is removed by heat making the isocyanate available for reaction with another functional group such as OH or epoxy.

[0129] In addition, in some embodiments the non grafted particles become grafted to the host resin prior to curing. Therefore the benefits of using the non grafted particles when the resin is being used can be achieved, while then getting the benefits of grafted particles in the final cured resin. Non-grafted particles later become grafted to the host resin, the application of energies such as temperature, laser, and ultraviolet light can be utilized. The latent catalysts and blocked Isocyanates would also be applicable here.

[0130] Although both classes of particles will end up being in the final cured resin, the two classes may be mixed with the resin at different times. The non grafted particles in particular may be mixed with the resin after the grafted particles. This may be desirable if the non grafted particles have a tendency to, over time, react with the resin. In other cases, the non grafted particles are mixed in with the resin at a different stage. For example, the non grafted particles may be present on a target, such as a dry tape, and are picked up by the resin as it is impregnated onto/into the target.

[0131] Referring to FIG. 3, a mix of grafted 31 and non grafted 30 particles are present in a host resin 32. In this example, the smaller grafted particles 31 have been surface treated so that they aggregate with each other, forming dendritic type structures. Each grafted particle may be grafted to multiple resin molecules 33. The non-grafted particles 30 do not readily react with one another, or with the grafted par-

ticles, and are thus more evenly distributed. This may be changed, and in another example the non grafted can be made to aggregate to the grafted dendritic structures.

[0132] In regards to surface coated fillers, the orientation, position and structural organization of the fillers may be controlled either through the selected nature of the surface coating to align and aggregate itself, or by the application an external field. Examples of such fields are magnetic, electric and mechanical (AC/dynamic, DC/static, pulsed and combinations thereof), sonic and ultrasonic. For example, dielectrophoresis or electrophoresis may be used. Coatings such as TiO₂ would respond to electric fields, while coatings containing or consisting of Ni, Co, Mn, V, Cr, or Fe compounds would respond to magnetic fields, in either a paramagnetic or ferromagnetic manner. Organo-metallic compound may also be used, such as metal acetylacetonates, ferrocene, metal porphyrins and metal phthalocyanines.

[0133] It is also possible that HTC materials can be surface coated onto non-HTC fillers that are responsive to the fields mentioned above. For example, a TiO₂ core could be given a BN surface coating. This can in fact be more effective than putting a field responsive surface coating onto an HTC filler, since by this method the bulk of the filler will be responsive to the field, while heat passing to the filler will tend to travel along the surface. Non grafted particles will tend to self-align more readily due to their lack of tethering and those which are surface treated to reduce viscosity in the liquid resin system will tend to align more easily in an electric field of force.

[0134] In one application the mix grafted and non grafted invention provides for high thermal conductivity resin that comprises a host resin matrix with a first class of grafted high thermal conductivity particles that are grafted to the host resin matrix. Also, a second class of non-grafted high thermal conductivity particles that are not directly grafted to the host resin matrix. The first class and the second class comprise approximately 2-60% by volume of the high thermal conductivity resin. The first class of grafted particles and the second class of non-grafted particles are high thermal conductivity fillers are from 1-1000 nm in length, and have an aspect ratio of between 3-100.

[0135] In particular embodiments the first class and the second class comprise approximately 25-40%. The second class of non-grafted particles can be surface treated to not react with other particles with their class. Also the second class of non-grafted particles can be surface treated to react with other particles with their class to form aggregations within the host resin matrix. And the first class of grafted particles can be surface treated to react with the second class of non-grafted particles.

[0136] In other particular embodiments the first class of grafted particles have an average length distribution at least ten times greater than the second class of non-grafted particles. The host resin network includes epoxy, polyimide epoxy, liquid crystal epoxy, cyanate-ester, polybutadiene, and appropriate mixtures of the foregoing. The high thermal conductivity resin is impregnated into a composite tape, and the second class of non-grafted particles can be incorporated into the high thermal conductivity resin after the high thermal conductivity resin is impregnated into the composite tape.

[0137] In still other embodiments non grafted becomes grafted to the host resin by the application of at least one of increased temperature and ultraviolet light. The thermal conductivity particles are at least one of oxides, nitrides, and carbides.

[0138] In another application the mix grafted and non grafted invention provides for high thermal conductivity resin that comprises a host resin matrix, a first class of grafted high thermal conductivity particles that are grafted to the host resin matrix, and a second class of non-grafted high thermal conductivity particles that are not grafted to the host resin matrix. Although the first class of particles may provide some thermal conductivity benefit, they do not necessarily have to be of the HTC type particle described herein. The first class and the second class comprise approximately 4-60% by volume of the high thermal conductivity resin. The first class of grafted particles and the second class of non-grafted particles are high thermal conductivity fillers are from 5-1000 nm in length, and have an aspect ratio of between 3-100, and each of the classes of particles comprises at least 1% by volume of high thermal conductivity resin. In some cases the first class of grafted particles have a higher mechanical strength than the second class of non-grafted particles.

[0139] In a particular embodiment the resin is impregnated into a porous media, such as a paper or glass fibre matrix or printed circuit boards; a glass fibre matrix is impregnated with resin to make a laminate for a printed circuit board. The ratios of the first class of grafted particles and the second class of non-grafted particles can be made different in different parts of the porous media due to a greater filtering effect that the porous media has on the second class of non-grafted particles. In some cases the ratios of the first class of grafted particles and the second class of non-grafted particles are different in different parts of the porous media due to the original positioning of the particles.

[0140] In still another application the mix grafted and non grafted invention provides for a high thermal conductivity resin that comprises a host resin matrix and a first class of grafted particles that are grafted to the host resin matrix; the grafted particles increase the local strength of the host resin matrix. Also, a second class of non-grafted high thermal conductivity particles that are not grafted to the host resin matrix. The first class and the second class comprise approximately 2-60% by volume of the high thermal conductivity resin, and the second class of non-grafted particles are high thermal conductivity fillers are from 1-1000 nm in length, and have an aspect ratio of between 3-100.

[0141] In particular embodiments the second class of non-grafted particles have an average length of 2-10 times that of the first class of grafted particles. Applications of this embodiment include the longer, non-grafted particles increasing the thermal conductivity, while the shorter grafted particles increase localized strength of the resin. In some embodiments a third class of non-grafted particles that are not high thermal conductivity particles are present in the host resin matrix.

[0142] In other particular embodiments at least a portion of the first class of grafted particles are high thermal conductivity fillers from 1-1000 nm in length, and have an aspect ratio of between 3-100. In other embodiments the grafted particles increase the dielectric strength of the host resin matrix.

[0143] Although the present invention has been discussed primarily in use with electrical industries, the invention is equally applicable in other areas. Industries that need to increase heat transference would equally benefit from the present invention. For example, the energy, chemical, process and manufacturing industries, inclusive of oil and gas, and the automotive and aerospace industries. Other focuses of the present invention include power electronics, conventional

electronics, and integrated circuits where the increasing requirement for enhanced density of components leads to the need to remove heat efficiently in local and large areas. Also, while specific embodiments of the invention have been described in detail, it will be appreciated by those skilled in the art that various modifications and alternatives to those details could be developed in light of the overall teachings of the disclosure. Accordingly, the particular arrangements disclosed are meant to be illustrative only and not limiting as to the scope of the inventions which, is to be given the full breadth of the claims appended and any and all equivalents thereof.

1.-22. (canceled)

23. A high thermal conductivity resin comprising:

a host resin matrix;

a first class of grafted high thermal conductivity particles that are grafted to said host resin matrix; and

a second class of non-grafted high thermal conductivity particles that are not directly grafted said host resin matrix;

wherein said first class and said second class comprise approximately 2-60% by volume of said high thermal conductivity resin;

wherein said first class of grafted particles and said second class of non-grafted particles are high thermal conductivity fillers are from 1-1000 nm in length, and have an aspect ratio of between 3-100.

24. The resin of claim **23**, wherein said first class and said second class comprise approximately 25-40%.

25. The resin of claim **23**, wherein said second class of non-grafted particles have been surface treated to not react with other particles with their class.

26. The resin of claim **23**, wherein said second class of non-grafted particles have been surface treated to react with other particles with their class to form aggregations within the host resin matrix.

27. The resin of claim **23**, wherein said first class of grafted particles have been surface treated to react with said second class of non-grafted particles.

28. The resin of claim **23**, wherein said first class of grafted particles have an average length distribution at least ten times greater than said second class of non-grafted particles.

29. The resin of claim **23**, wherein said host resin network includes epoxy, polyimide epoxy, liquid crystal epoxy, cyanate-ester, polybutadiene, and mixtures thereof.

30. The resin of claim **23**, wherein high thermal conductivity resin is impregnated into a composite tape.

31. The resin of claim **31**, wherein said second class of non-grafted particles are incorporated into said high thermal conductivity resin after said high thermal conductivity resin is impregnated into said composite tape.

32. The resin of claim **23**, wherein non grafted becomes grafted to said host resin by the application of at least one of increased temperature and ultraviolet light.

33. The resin of claim **23**, wherein the thermal conductivity particles are at least one of oxides, nitrides, and carbides.

34. A high thermal conductivity resin comprising:

a host resin matrix;

a first class of grafted high thermal conductivity particles that are grafted to said host resin matrix; and

a second class of non-grafted high thermal conductivity particles that are not grafted to said host resin matrix;

wherein said first class and said second class comprise approximately 4-60% by volume of said high thermal conductivity resin;

wherein said first class of grafted particles and said second class of non-grafted particles are high thermal conductivity fillers are from 5-1000 nm in length, and have an aspect ratio of between 3-100;

wherein each of said classes of particles comprises at least 1% by volume of high thermal conductivity resin.

35. The resin of claim **34**, wherein the resin is impregnated into a porous media.

36. The resin of claim **35**, wherein the porous media is a paper matrix.

37. The resin of claim **35**, wherein the ratios of said first class of grafted particles and said second class of non-grafted particles are different in different parts of said porous media due to a greater filtering effect that the porous media has on said second class of non-grafted particles.

38. The resin of claim **35**, wherein the ratios of said first class of grafted particles and said second class of non-grafted particles are different in different parts of said porous media due to the original positioning of the particles.

39. The resin of claim **34**, wherein said first class of grafted particles have a higher mechanical strength than said second class of non-grafted particles.

40. A high thermal conductivity resin comprising:

a host resin matrix;

a first class of grafted particles that are grafted to said host resin matrix, wherein said grafted particles increase the local strength of said host resin matrix; and

a second class of non-grafted high thermal conductivity particles that are not grafted to said host resin matrix; wherein said first class and said second class comprise approximately 2-60% by volume of said high thermal conductivity resin;

wherein said class of non-grafted particles are high thermal conductivity fillers are from 1-1000 nm in length, and have an aspect ratio of between 3-100.

41. The resin of claim **40**, wherein said second class of non-grafted particles have an average length of 2-10 times that of said first class of grafted particles.

42. The resin of claim **40**, wherein at least a portion of said first class of grafted particles are high thermal conductivity fillers from 1-1000 nm in length, and have an aspect ratio of between 3-100.

43. The resin of claim **40**, wherein a third class of non-grafted particles that are not high thermal conductivity particles are present in said host resin matrix.

44. The resin of claim **40**, wherein said grafted particles increase the dielectric strength of said host resin matrix.

* * * * *