

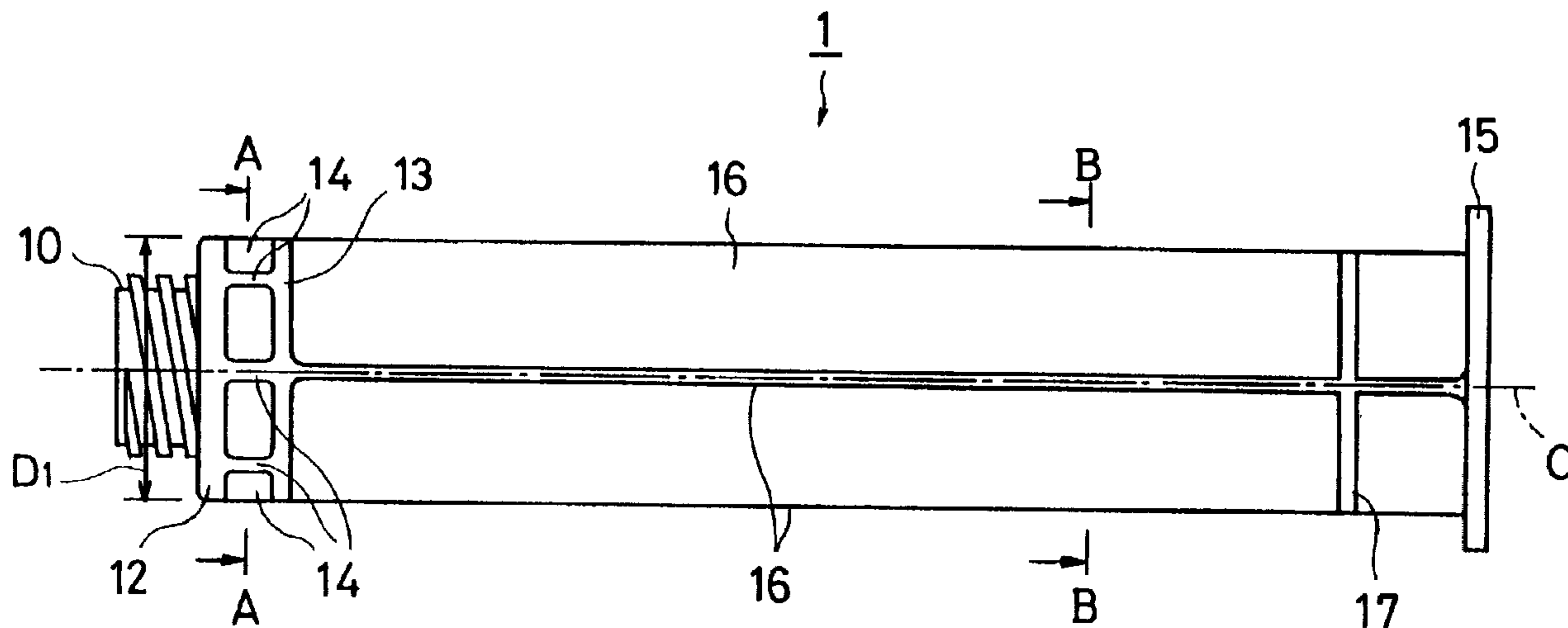

(86) Date de dépôt PCT/PCT Filing Date: 2000/07/14
 (87) Date publication PCT/PCT Publication Date: 2001/01/25
 (45) Date de délivrance/Issue Date: 2007/05/15
 (85) Entrée phase nationale/National Entry: 2002/01/14
 (86) N° demande PCT/PCT Application No.: JP 2000/004754
 (87) N° publication PCT/PCT Publication No.: 2001/005456
 (30) Priorité/Priority: 1999/07/15 (JP11/201814)

(51) Cl.Int./Int.Cl. *A61M 5/315* (2006.01)
 (72) Inventeurs/Inventors:
 IJIMA, KAZUMI, JP;
 YANASE, KAZUYUKI, JP
 (73) Propriétaires/Owners:
 BRACCO INTERNATIONAL B.V., NL;
 DAIKYO SEIKO, LTD., JP
 (74) Agent: RICHES, MCKENZIE & HERBERT LLP

(54) Titre : PISTON POUR SERINGUE
 (54) Title: PLUNGER FOR SYRINGE



(57) Abrégé/Abstract:

A gasket 7 used for a prefilled syringe 1 in which liquid 3 is filled, having a constriction 8 on its circumferential side face in contact with an inner surface of a syringe barrel 2 and having a bottom face 7c which is not in contact with the liquid 3 whose circumference is formed in a tapered shape.

FESI01001

(12/13)

ABSTRACT

A gasket 7 used for a prefilled syringe 1 in which liquid 3 is filled, having a constriction 8 on its circumferential side face in contact with an inner surface of a syringe barrel 2 and having a bottom face 7c which is not
5 in contact with the liquid 3 whose circumference is formed in a tapered shape.

FESI01001

(1/13)

DESCRIPTION

PLUNGER FOR SYRINGE

5 Technical Field

The present invention relates to a plunger for a syringe used for supporting and moving a gasket inserted in a syringe barrel.

Background Art

10 In a general syringe, a liquid medicine is inhaled into its syringe barrel when it is used, but recently a prefilled syringe in which the liquid medicine is previously filled in the syringe barrel was developed to reduce a working load at a medical site. A prefilled syringe in which a contrast medium is filled in its syringe barrel has also come into use lately. Moreover,
15 a prefilled plastic syringe in which a contrast medium is previously filled in its plastic syringe having comparatively large capacity is also used these days.

When such a syringe is used, a plunger is inserted from a rear end of the syringe barrel and a screw portion formed at a tip of the plunger is screwed in a rear face of a gasket so that the gasket is mounted at the tip of
20 the plunger. The gasket is thus mounted at the tip of the plunger and the gasket is pushed via the plunger, which causes the liquid medicine to be injected into a body or the like. Further, since the contrast medium has comparatively high viscosity and resistance when the contrast medium is injected into the body via a blood-vessel, spinal cord, or the like is large,
25 pressure injection is generally performed using a device such as an auto-injector in a case of using the syringe in which the contrast medium is filled.

When the gasket is mounted at the tip of the plunger in this way, if a center axis of the syringe barrel and a center axis of the plunger are not in a state of coinciding with each other, the screw portion at the tip of the plunger cannot be smoothly screwed into the rear face of the gasket. However, it is not easy to make the center axis of the syringe barrel and the center axis of the plunger coincide with each other and the screw portion at the tip of the plunger is sometimes forced to be screwed into the rear face of the gasket in a state in which both of the center axes deviate from each other.

However, if the gasket is mounted on the screw portion at the tip of the plunger in the state in which the center axis of the syringe barrel and the center axis of the plunger deviate from each other, the gasket at the tip of the plunger becomes in a skewed position (a position in which the center axis of the gasket deviates from the center axis of the plunger) and the gasket becomes unable to smoothly move in the syringe barrel, which causes a problem that performance in filling the liquid medicine deteriorates. In addition, as a result of the gasket being in the skewed position, clearance is made between an inner surface of the syringe barrel and an outer circumferential surface of the gasket and fluid leakage easily occurs from the clearance.

It is an object of the present invention to provide a plunger for a syringe in which a gasket can be mounted on a screw portion at a tip of the plunger in a state in which a center axis of a syringe barrel and a center axis of the plunger are easily made to coincide with each other.

Disclosure of the Invention

In order to achieve the object, the present invention provides a plunger for a syringe used for supporting and moving a gasket inserted in a syringe barrel, which is characterized

in that it comprises: a screw portion formed at a tip thereof for mounting the gasket; a pair of ring members arranged at an interval from each other at the rear of the screw portion around a center axis of the plunger; and a plurality of vane members arranged radially from the center axis of the plunger between the ring members, and that outer diameters of the ring members and the vane members are equal to an inner diameter of the syringe barrel or slightly smaller than the inner diameter.

In the plunger of the present invention, the interval between the pair of ring members arranged at the rear of the screw portion is preferably, for example, 0.5 mm or larger. As for the plunger according to the present invention, when the syringe is used, the plunger is inserted from a rear end of the syringe barrel and outer circumferential surfaces of the pair of ring members arranged at the interval from each other at the rear of the screw portion and outer circumferential surfaces of the vane members abut on an inner surface of the syringe barrel to guide the plunger, which indicates that a center axis of the syringe barrel and the center axis of the plunger naturally become in a state of coinciding with each other when the plunger is inserted from the rear end of the syringe barrel. Therefore, using the plunger according to the present invention, the center axis of the syringe barrel and the center axis of the plunger are made to coincide with each other easily without precise positioning, which makes it possible to mount the gasket at the tip of the plunger in a correct state (a position in which a center axis of the gasket coincides with the center axis of the plunger). As a result, the gasket can move smoothly in the syringe barrel, which prevents deterioration of performance in filling a liquid medicine and fluid leakage from a part between the inner surface of the syringe barrel and the outer circumferential surface of the gasket.

In the plunger according to the present invention, it is also suitable that the liquid medicine is previously filled in the syringe barrel. Preferably, eight pieces of the vane members are arranged, for example, at regular intervals and at 5 central angles of 45°.

Preferably, it is also suitable that the plunger further comprises a flange portion formed at a rear end of the plunger; and one or two or more gripping ring members arranged near the front of the flange portion around the center axis of the 10 plunger, and that outer diameters of the gripping ring members are equal to the inner diameter of the syringe barrel or slightly smaller than the inner diameter. Preferably disclosed is a plunger for a syringe used for supporting and moving a gasket inserted in a syringe barrel, which is characterized in 15 that it comprises: a screw portion formed at a tip thereof for mounting the gasket; a flange portion formed at a rear end thereof; and one or two or more gripping ring members arranged near the front of the flange portion around a center axis of the plunger, and that outer diameters of the gripping ring 20 members are equal to an inner diameter of the syringe barrel or slightly smaller than the inner diameter.

Preferably, when the plunger is inserted from a rear end of the syringe barrel, the gripping ring members can be gripped so that the tip of the plunger can be easily inserted.

25 In another aspect, the present invention provides a plunger for a syringe used for supporting and moving a gasket inserted in a syringe barrel, comprising: a screw portion formed at a tip thereof for mounting the gasket; a pair of ring members arranged at an interval from each other at a rear of 30 said screw portion around a center axis of the plunger; and a plurality of vane members arranged radially from the center axis of the plunger between said ring members; wherein outer

4a

diameters of said ring members and said vane members are equal to an inner diameter of the syringe barrel or slightly smaller than the inner diameter, wherein eight pieces of said vane members are arranged at regular intervals and at central angles
5 of 45°.

Brief Description of Drawings

FIG. 1 is a side view of a plunger according to an embodiment of the present invention;

10 FIG. 2 is a front view of the plunger seen from a tip of the plunger;

FESI01001

(5/13)

FIG. 3 is a cross-sectional view taken along the A-A line in FIG. 1;

FIG. 4 is a cross-sectional view taken along the B-B line in FIG. 1;

FIG. 5 is an explanatory view in a state in which the plunger according to the embodiment of the present invention is inserted in a syringe;

5 and

FIG. 6 is an explanatory view in a state in which a gasket is mounted on the tip of the plunger.

Best Mode for Carrying out the Invention

10 A preferred embodiment of the present invention will be explained below with reference to the drawings.

At a tip of a plunger 1, a screw portion 10 for mounting a gasket 25 provided in a later-described syringe 2 is formed. At the rear of the screw portion 10 (the right in FIG. 1), a pair of ring members 12 and 13 are arranged at an interval from each other and a plurality of vane members 14 are arranged between the ring members 12 and 13. One of the ring members 12 is arranged in contact with the screw portion 10 at the tip of the plunger 1 while the other one of the ring members 13 is arranged at the rear of the one of the ring members 12 at the interval therebetween, and the interval between the ring members 12 and 13 is 0.5 mm or larger.

Each of the ring members 12 and 13 has a discoidal shape around a center axis O of the plunger 1. Diameters D1 of the ring members 12 and 13 are equal to an inner diameter D of a syringe barrel 20 of a later-described syringe 2 or slightly smaller than the inner diameter D of the syringe barrel 20.

In this embodiment, eight pieces of the vane members 14 are arranged

FESI01001

(6/13)

between the ring members 12 and 13. As shown in FIG. 3, the vane members 14 are arranged radially from the center axis O of the plunger 1 and the vane members 14 are arranged around the center axis O of the plunger 1 at regular intervals and at central angles of 45° . An outer diameter D2 of the vane members 14 is also equal to the inner diameter D of the syringe barrel 20 of the later-described syringe 2 or slightly smaller than the inner diameter D of the syringe barrel 20.

At a rear end of the plunger 1 (the right end in FIG. 1), a flange 15 is formed. Further, between the flange 15 and the ring member 13, a rib 16 whose cross-sectional shape is a shape of a cross as shown in FIG. 4 is provided. Furthermore, a gripping ring member 17 is arranged near the front (near the left in FIG. 1) of the flange portion 15 at the rear end of the plunger 1. The gripping ring member 17 has also a discoidal shape around the center axis O of the plunger 1. In addition, a diameter D3 of the gripping ring member 17 is also equal to the inner diameter D of the syringe barrel 20 of the later-described syringe 2 or slightly smaller than the inner diameter D of the syringe barrel 20. The plunger 1 as described above can be integrally molded of plastic such as, for example, polypropylene.

As shown in FIG. 5, in the syringe 2, at a tip (the left end in FIG. 5) of the syringe barrel 20 which has a cylindrical shape, a lure lock portion 21 is provided, and the lure lock portion 21 is in a state of being covered by a cap 22 before the syringe 2 is used. The inner diameter D of the syringe barrel 20 is equal to the diameters D1 of the ring members 12 and 13, the diameter D3 of the gripping ring member 17, and the outer diameter D2 of the vane members 14 explained above, or slightly larger than the diameters D1 of the ring members 12 and 13, the diameter D3 of the gripping ring member 17,

FESI01001

(7/13)

and the outer diameter D2 of the vane members 14. Material of the above-described syringe barrel 2 is plastic such as a cyclic polyolefin resin, for example.

In the syringe barrel 20, liquid 23 such as, for example, a contrast medium is filled. Further, a gasket 25 having a substantially columnar shape is inserted in the syringe barrel 20 from an open rear end (the right end in FIG. 5) of the syringe barrel 20, and by the insertion of the gasket 25 in the syringe barrel 20, the liquid 23 is in a state of being sealed in the syringe barrel 20. An outer circumferential surface of the gasket 25 is in close contact with an inner surface of the syringe barrel 20, and thereby, the liquid 23 is not leaked from a part between the outer circumferential surface of the gasket 25 and the inner surface of the syringe barrel 20. In a rear face of the gasket 25 (the right end face in FIG. 5), a screw hole 26 into which the screw portion 10 formed at the tip of the aforesaid plunger 1 is screwed is formed.

Here, when the syringe 2 is used, the tip of the plunger 1 according to the embodiment of the present invention is first inserted from the rear end of the syringe barrel 20. In this case, in the plunger 1 of the embodiment, since the gripping ring member 17 is arranged near the front of the flange portion 15 at the rear end of the plunger 1, the gripping ring member 17 can be gripped when the plunger 1 is thus inserted from the rear end of the syringe barrel 1 and the plunger 1 can be easily inserted.

When the tip of the plunger 1 is inserted from the rear end of the syringe barrel 20 in this way, as shown in FIG. 5, outer circumferential surfaces of the ring members 12 and 13 and outer circumferential surfaces of the vane members 14 abut on the inner surface of the syringe barrel 20 to guide the plunger 1 so that the center axis O of the plunger 1 naturally

FESI01001

(8/13)

becomes in a state in which it coincides with a center axis of the syringe barrel 20. In the state in which the center axis O of the plunger 1 coincides with the center axis of the syringe barrel 20, the plunger 1 is pushed straight into the syringe barrel 20 and the plunger 1 is further turned to screw the screw portion 10 at the tip of the plunger 1 into the screw hole 26 on the rear face of the gasket 25 so that the gasket 25 can be mounted at the tip of the plunger 1 in a correct position (a position in which the center axis of the gasket 25 is made to coincide with the center axis of the plunger 1) as shown in FIG. 6.

10 On the other hand, as shown in FIG. 6, an end of an extension tube 30, for example, is set at the lure lock portion 21 at the tip of syringe barrel 20. The gasket 25 is then pushed via the plunger 1 and thereby the liquid medicine 23 can be injected into an intended position in a body or the like through the extension tube 30.

15 Although an example in which only one of the gripping ring member 17 is provided near the front of the flange portion 15 at the rear end of the plunger 1 is explained in the embodiment shown in the drawings, two or more of the gripping ring members 17 may be provided near the front of the flange portion 15. Incidentally, an example of the plunger 1 in which the pair of ring members 12 and 13 and the gripping ring member 17 are formed around the center axis O of the plunger 1 and the vane members 14 are arranged radially from the center axis O of the plunger 1 is explained above, but it can be also considered that the whole plunger is formed in a round rod shape having a diameter equal to the inner diameter D of the syringe barrel 20 or slightly smaller than the inner diameter D instead of providing the aforesaid ring members 12, 13, and 17 and vane members 14. If the whole

FESI01001

(9/13)

plunger is so formed in the round rod shape, however, a so-called dimensional shrink is caused in dimensional finishing when molded, which makes it difficult to obtain a plunger of accurate size. Accordingly, if the plunger is structured to have the ring members 12, 13, and 17 and the vane members 14, as the plunger 1 explained in the embodiment of the present invention, such a dimensional shrink can be prevented and the plunger 1 of accurate size can be obtained.

Industrial Availability

10 According to claims 1 to 4, it becomes possible to make a center axis of a syringe barrel and a center axis of a plunger coincide with each other easily without precise positioning so that a gasket can be mounted at a tip of the plunger in a correct position in which a center axis of the gasket coincides with the center axis of the plunger. Therefore, when the syringe is used, the gasket can move in the syringe barrel smoothly, which prevents deterioration of performance in filling a liquid medicine and fluid leakage from a part between an inner surface of the syringe barrel and an outer circumferential surface of the gasket. Further, according to claims 4 and 5, when the plunger is inserted from a rear end of the syringe barrel, a gripping ring member can be gripped so that the tip of the plunger can be easily inserted.

CLAIMS:

1. A plunger for a syringe used for supporting and moving a gasket inserted in a syringe barrel, comprising:

a screw portion formed at a tip thereof for mounting the gasket;

a pair of ring members arranged at an interval from each other at a rear of said screw portion around a center axis of the plunger; and

a plurality of vane members arranged radially from the center axis of the plunger between said ring members;

wherein outer diameters of said ring members and said vane members are equal to an inner diameter of the syringe barrel or slightly smaller than the inner diameter, wherein eight pieces of said vane members are arranged at regular intervals and at central angles of 45°.

2. The plunger for a syringe according to claim 1 wherein a rib is provided between one of the ring members and a flange portion at a rear end of said plunger.

3. The plunger for a syringe according to claim 1, further comprising:

a flange portion formed at a rear end of the plunger; and
one or two or more gripping ring members arranged near a front of the flange portion around the center axis of the plunger;

wherein outer diameters of said gripping ring members are equal to the inner diameter of the syringe barrel or slightly smaller than the inner diameter.

FESI01001

(13/13)

Explanation of Codes

	1	plunger
	2	syringe
5	10	screw portion
	12, 13	ring member
	14	vane member
	15	flange
	16	rib
10	17	ring member
	20	syringe barrel
	21	lure lock portion
	22	cap
	23	liquid
15	25	gasket
	26	screw hole
	30	extension tube

FIG. 1

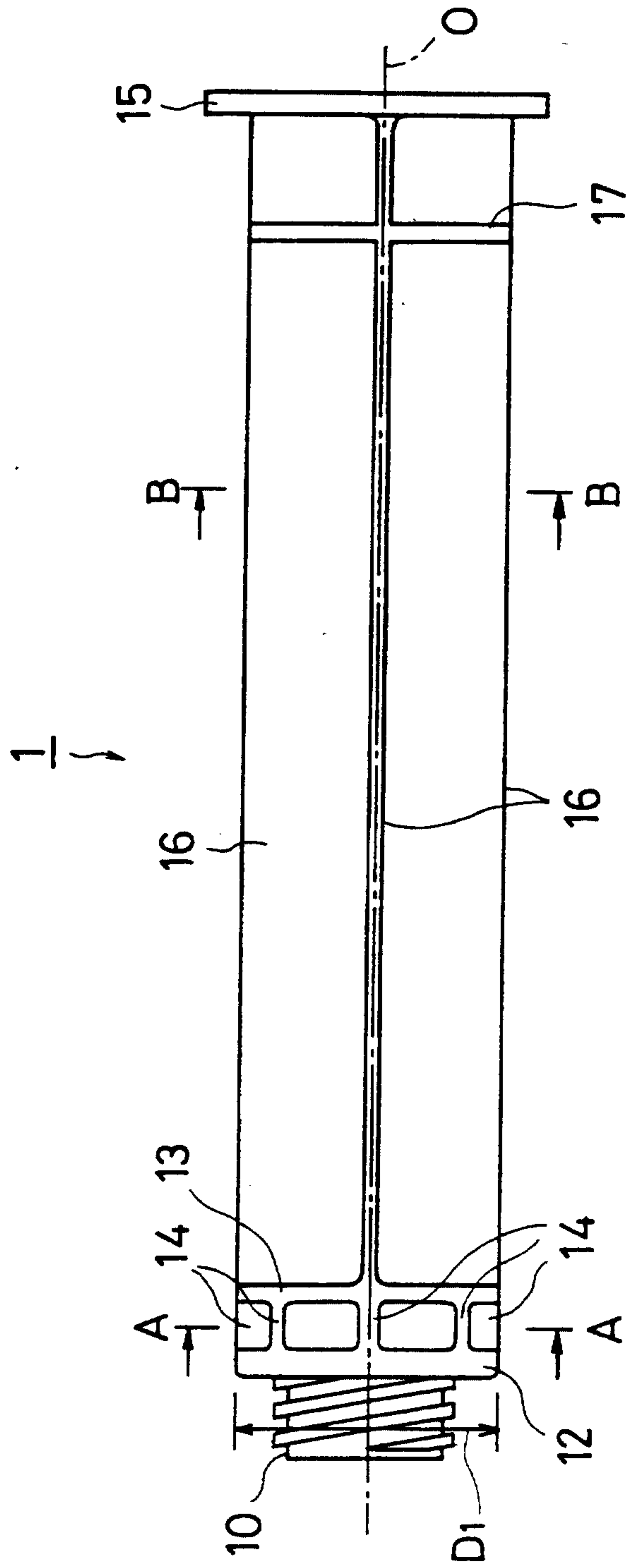

FIG. 2

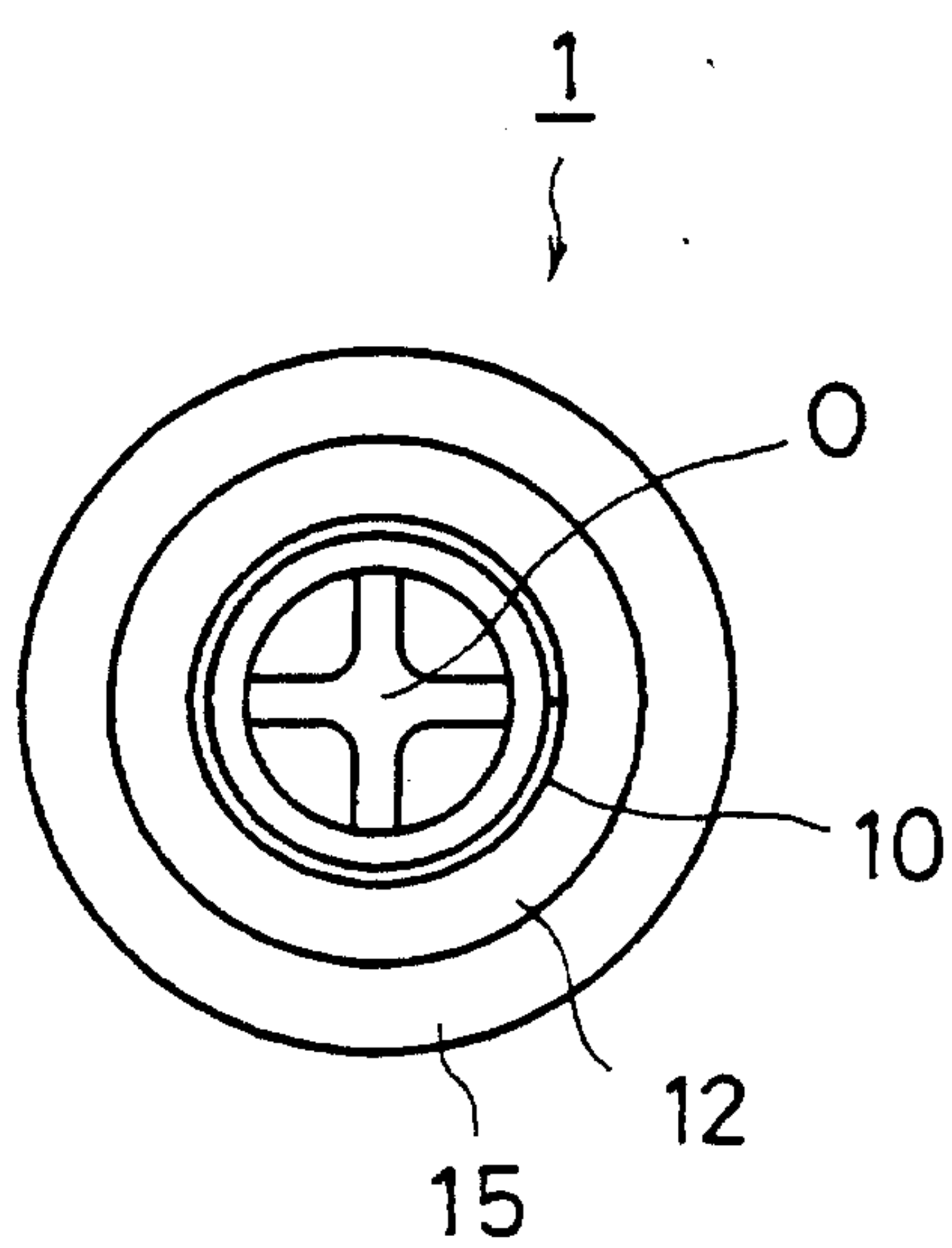

FIG. 3

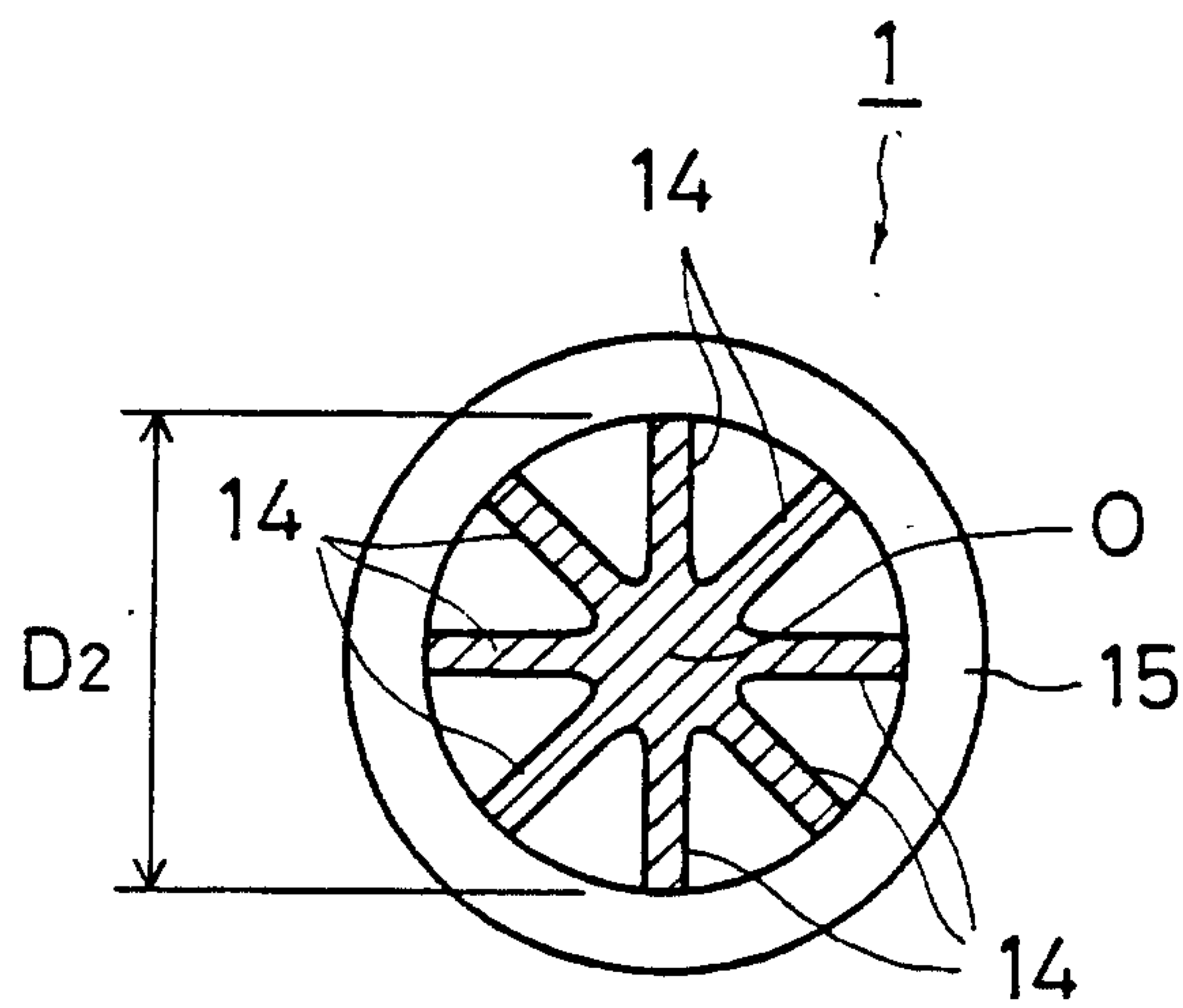

FIG. 4

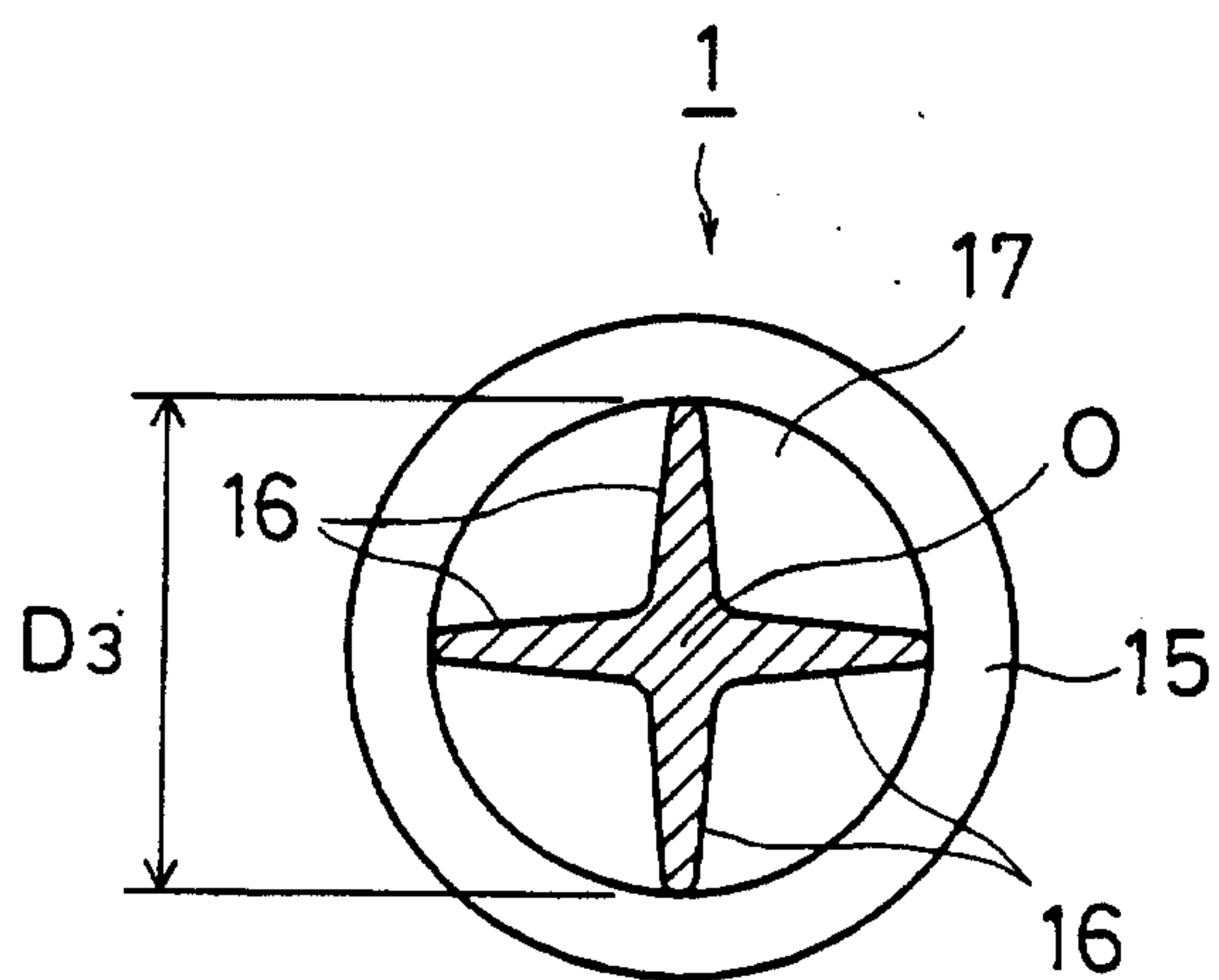

FIG. 5

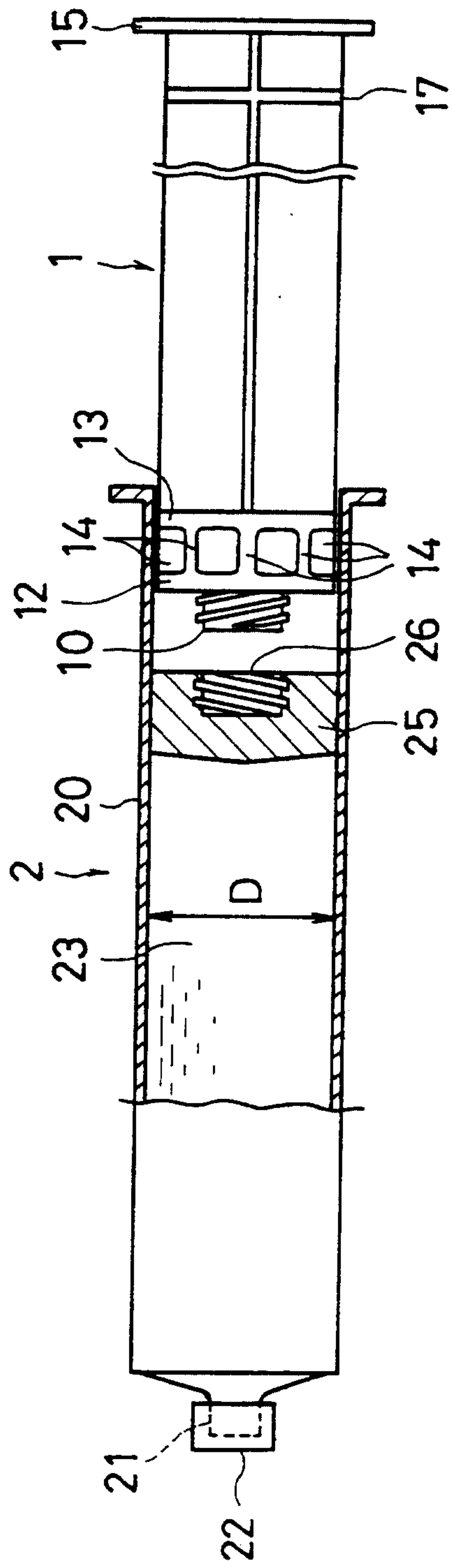

FIG. 6

