

(19) World Intellectual Property Organization
International Bureau



(43) International Publication Date
26 April 2001 (26.04.2001)

PCT

(10) International Publication Number
WO 01/29776 A1

(51) International Patent Classification⁷: G07B 17/00

(74) Agent: TABANDEH, Raymond, R.; Christie, Parker & Hale, LLP, P.O. Box 7068, Pasadena, CA 91109-7068 (US).

(21) International Application Number: PCT/US00/28600

(22) International Filing Date: 16 October 2000 (16.10.2000)

(81) Designated States (*national*): AE, AG, AL, AM, AT, AU, AZ, BA, BB, BG, BR, BY, BZ, CA, CH, CN, CR, CU, CZ, DE, DK, DM, EE, ES, FI, GB, GD, GE, GH, GM, HR, HU, ID, IL, IN, IS, JP, KE, KG, KP, KR, KZ, LC, LK, LR, LS, LT, LU, LV, MA, MD, MG, MK, MN, MW, MX, NO, NZ, PL, PT, RO, RU, SD, SE, SG, SI, SK, SL, TJ, TM, TR, TT, TZ, UA, UG, US, UZ, VN, YU, ZA, ZW.

(25) Filing Language: English

(26) Publication Language: English

(30) Priority Data:

60/160,112	18 October 1999 (18.10.1999)	US
60/160,041	18 October 1999 (18.10.1999)	US
60/160,491	20 October 1999 (20.10.1999)	US
60/160,503	20 October 1999 (20.10.1999)	US
60/160,563	20 October 1999 (20.10.1999)	US
60/193,057	29 March 2000 (29.03.2000)	US
60/193,055	29 March 2000 (29.03.2000)	US
60/193,056	29 March 2000 (29.03.2000)	US

(84) Designated States (*regional*): ARIPO patent (GH, GM, KE, LS, MW, MZ, SD, SL, SZ, TZ, UG, ZW), Eurasian patent (AM, AZ, BY, KG, KZ, MD, RU, TJ, TM), European patent (AT, BE, CH, CY, DE, DK, ES, FI, FR, GB, GR, IE, IT, LU, MC, NL, PT, SE), OAPI patent (BF, BJ, CF, CG, CI, CM, GA, GN, GW, ML, MR, NE, SN, TD, TG).

(71) Applicant (*for all designated States except US*): STAMPS.COM [US/US]; Suite 1040, 3420 Ocean Park Boulevard, Santa Monica, CA 90405 (US).

Published:

- With international search report.
- Before the expiration of the time limit for amending the claims and to be republished in the event of receipt of amendments.

(72) Inventors; and

(75) Inventors/Applicants (*for US only*): OGG, Craig, L. [US/US]; 4405 Cerritos Avenue, Long Beach, CA 90807 (US). CHOW, William, W. [US/US]; 3409 Stoner Avenue, Los Angeles, CA 90066 (US).

For two-letter codes and other abbreviations, refer to the "Guidance Notes on Codes and Abbreviations" appearing at the beginning of each regular issue of the PCT Gazette.

(54) Title: CRYPTOGRAPHIC MODULE FOR SECURE PROCESSING OF VALUE-BEARING ITEMS

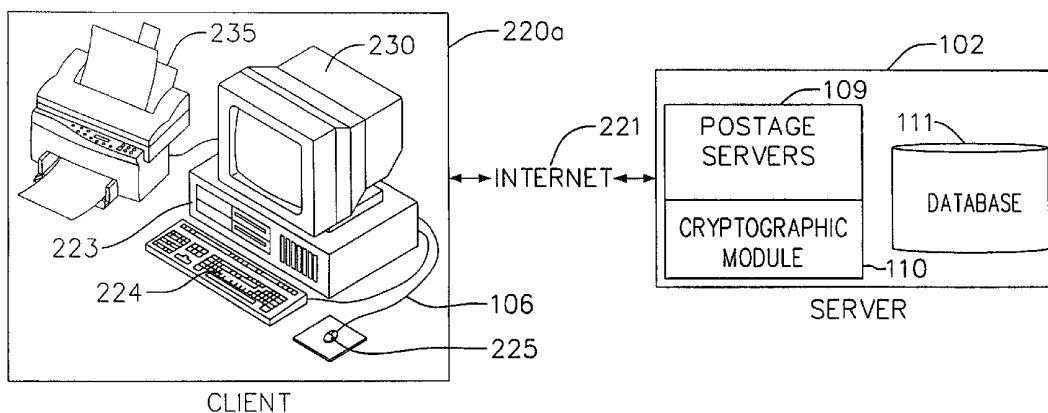

(57) Abstract: An on-line value bearing item (VBI) printing system that includes one or more cryptographic modules and a central database is disclosed. The cryptographic modules are capable of implementing the USPS Information Based Indicia Program Postal Security Device Performance Criteria and other required VBI standards. The modules encipher the information stored in the central database for all of the on-line VBI system customers and are capable of preventing access to the database by unauthorized users. Additionally, the cryptographic module is capable of preventing unauthorized and undetected modification, including the unauthorized modification, substitution, insertion, and deletion of VBI related data and cryptographically critical security parameters.

WO 01/29776 A1

1 CRYPTOGRAPHIC MODULE FOR SECURE PROCESSING
OF VALUE-BEARING ITEMS

FIELD OF THE INVENTION

5 The present invention relates to secure printing of value-bearing items (VBI) preferably, postage. More specifically, the invention relates to a cryptographic module for secure printing of VBIs.

BACKGROUND OF THE INVENTION

10 A significant percentage of the United States Postal Service (USPS) revenue is from metered postage. Metered postage is generated by utilizing postage meters that print a special mark, also known as postal indicia, on mail pieces. Generally, printing postage and any VBI can be carried out by using mechanical meters or computer-based systems.

15 With respect to computer-based postage processing systems, the USPS under the Information-Based Indicia Program (IBIP) has published specifications for IBIP postage meters that identify a special purpose hardware device, known as a Postal Security Device (PSD) that is generally located at a user's site. The PSD, in conjunction with the user's personal computer and printer, functions as the IBIP postage meter. The USPS has published a number of documents describing the PSD specifications, the indicia specifications and other related and
20 relevant information. There are also security standards for printing other types of VBI, such as coupons, tickets, gift certificates, currency, voucher and the like.

25 A significant drawback of existing hardware-based systems is that a new PSD must be locally provided to each new user, which involves significant cost. Furthermore, if the additional PSD breaks down, service calls must be made to the user location. In light of the drawbacks in hardware-based postage metering systems, a software-based system has been developed that does not require specialized hardware for each user. The software-based system meets the IBIP specifications for a PSD, using a centralized server-based implementation of PSDs utilizing one or more cryptographic modules. The system also includes a database for all users' information. The software-based system, however, has brought about new challenges.

30 The software-based system should be able to handle secure communications between users and the database. In a hardware-based system, security is generally handled by the local hardware piece, that is unique to each user and includes an encryption processor that encrypts that user's information and communications. However, as mentioned above, this hardware-based system has significant disadvantages.

35 Therefore, there is a need for a new method and apparatus for implementation of VBI secure printing and a secure IBIP postage meter over a WAN that does not require the special purpose hardware device at the user site. Furthermore, there is a need for a secure system and database that are capable of preventing unauthorized access and tampering.

1 SUMMARY OF THE INVENTION

In accordance with one aspect of the present invention, an on-line VBI printing system that includes one or more cryptographic modules and a central database has been designed. The cryptographic modules serve the function of the PSDs and are capable of implementing the USPS
5 Information Based Indicia Program Postal Security Device Performance Criteria and the cryptographic security requirements specified by Federal Information Processing Standards (FIPS) 140-1, Security Requirements for Cryptographic Modules, and other required standards. The modules encipher the information stored in the central database for all of the on-line VBI system customers and are capable of preventing access to the database by unauthorized users.
10 Also, a secure communication network is in operation to prevent unauthorized access to the users' data stored in the centralized database. Additionally, the cryptographic module is capable of preventing unauthorized and undetected modification, including the unauthorized modification, substitution, insertion, and deletion of VBI related data and cryptographically critical security parameters.

15 Each module prevents the unauthorized disclosure of the non-public contents of the VBI data, such as a postage meter, including plaintext cryptographic keys and other critical security parameters. The module also ensures the proper operation of cryptographic security and VBI related meter functions. The module detects errors in the operation of security mechanisms and prevents the compromise of meter data and critical cryptographic security parameters as a result
20 of those errors.

In one aspect the present invention is a method for securing data on a computer network including a plurality of users comprising the steps of: authenticating and authorizing the plurality of users for secure processing of a value bearing item; storing security device transaction data in a memory for ensuring authenticity and authority of one of the plurality of users, wherein the
25 security device transaction data is related to the one of the plurality of users; and including cryptographically protected data using a stored secret. The method is also capable of storing a plurality of security device transaction data in a database wherein, each transaction data is related to one of the plurality of users.

30 In another aspect the present invention describes a cryptographic device for securing data on a computer network comprising: a processor programmed to authenticate a plurality of users on the computer network for secure processing of a value bearing item; a memory for storing security device transaction data for ensuring authenticity of a user, wherein the security device transaction data is related to the one of the plurality of users; a cryptographic engine for cryptographically protecting data; and an interface for communicating with the computer
35 network.

It is to be understood that the present invention is useful for printing not only postage, but any VBIs, such as coupons, tickets, gift certificates, currency, voucher and the like.

1 BRIEF DESCRIPTION OF THE DRAWINGS

The objects, advantages and features of this invention will become more apparent from a consideration of the following detailed description and the drawings, in which:

5 FIG. 1 is an exemplary block diagram for the client/server architecture of one embodiment of the present invention;

FIG. 2 is an exemplary block diagram of a remote user computer connected to a server via Internet according to one embodiment of the present invention;

FIG. 3 is an exemplary block diagram of a cryptographic device according to one embodiment of the present invention;

10 FIG. 4 is an exemplary block diagram of servers, databases, and services according to one embodiment of the present invention;

FIG. 5 is an exemplary block diagram of a client software, a cryptographic module, and a typical transaction between them during an operational state according to one embodiment of the present invention;

15 FIG. 6 is an exemplary state transition diagram for a cryptographic device according to one embodiment of the present invention;

FIG. 7 is an exemplary diagram of audit chaining according to one embodiment of the present invention;

20 FIG. 8 is an exemplary diagram of multiple user PSD according to one embodiment of the present invention.;

FIG. 9 is an exemplary diagram of multiple users using a gateway server according to one embodiment of the present invention; and

25 FIG. 10 is an exemplary diagram of a browser-based design with or without a UI according to one embodiment of the present invention.

DETAILED DESCRIPTION

In one aspect, the system and method of the present invention prevent unauthorized electronic access to a database subsystem and secure customers' related data, among others. One level of security is achieved by protecting the database subsystem by a postal server subsystem. 30 The postal server subsystem controls preferably, all communications with the database subsystem by executing an authentication algorithm to prevent unauthorized access. Another level of security is achieved by encrypting preferably, all communications between the client system and the postal server subsystem. The encryption-decryption function is employed using commonly known algorithms, such as, Rivest, Shamir and Adleman ("RSA") public key encryption, DES, 35 Triple-DES, Pseudo-random number generation, and the like algorithms. Additionally, DSA signature, and SHA-1 hashing algorithms may be used to digitally sign a postage indicium.

Another measure of security is the interaction between a cryptographic module and the database subsystem whenever a PSD transaction (security device transaction) is initiated. The

1 cryptographic module and the database subsystem cross-verify the last PSD transaction (security
device transaction) before proceeding with the next PSD transaction. If the last transaction
record in the cryptographic module and the database subsystem do not match, then the on-line
postage system shuts down until the situation can be investigated. This verification process
5 protects against attempts of unauthorized individuals to replace the database subsystem. The
registers in the cryptographic modules are cryptographically protected to achieve another level
of security.

An exemplary on-line postage system is described in U.S. patent Application No.
09/163,993 filed September 15, 1998, the entire contents of which are hereby incorporated by
10 reference herein. The on-line postage system includes an authentication protocol that operates
in conjunction with the USPS requirements. The system utilizes on-line postage system software
comprising user code that resides on a client system and controller code that resides on a server
system. The on-line postage system allows a user to print a postal indicium at home, at the
office, or any other desired place in a secure, convenient, inexpensive and fraud-free manner.
15 The system comprises a user system electronically connected to a server system, which in turn
is connected to a USPS system.

Each of the cryptographic modules may be available for use by any user. When a user
requests a PSD service, one of the available modules is loaded with data belonging to the user's
account and the transaction is performed. When a module is loaded with a user's data ,that
20 module becomes the user's PSD. The database record containing each user's PSD data is
referred to as the "PSD package" (security device transaction data). After each PSD transaction
is completed, the user's PSD package is updated and returned to a database external to the
module. The database becomes an extension of the module's memory and stores not only the
items specified by the IBIP for storage inside the PSD, but also the user's personal cryptographic
25 keys and other security relevant data items (SRDI) and status information needed for continuous
operation. Movement of this sensitive data between the modules and the database is secured to
ensure that PSD packages could not be compromised.

In one embodiment, the server system is remotely located in a separate location from the
client system. All communications between the client and the server are preferably accomplished
30 via the Internet. FIG. 1 illustrates a remote client system 220a connected to a server system 102
via the Internet 221. The client system includes a processor unit 223, a monitor 230, printer port
106, a mouse 225, a printer 235, and a keyboard 224. Server system 102 includes Postage servers
109, Database 130, and cryptographic modules 110.

An increase in the number of servers within the server system 102 will not negatively
35 impact the performance of the system, since the system design allows for scalability. The Server
system 102 is designed in such a way that all of the business transactions are processed in the
servers and not in the database. By locating the transaction processing in the servers, increases
in the number of transactions can be easily handled by adding additional servers. Also, each

1 transaction processed in the servers is stateless, meaning the application does not remember the specific hardware device the last transaction utilized. Because of this stateless transaction design, multiple servers can be added to each appropriate subsystem in order to handle increased loads.

5 Furthermore, each cryptographic module is a stateless device, meaning that a PSD package can be passed to any device because the application does not rely upon any information about what occurred with the previous PSD package. Therefore, multiple cryptographic modules can also be added to each appropriate subsystem in order to handle increased loads. A PSD package for each cryptographic module is a database record, stored in the server database, that includes information pertaining to one customer's service that would normally be protected inside a
10 cryptographic module. The PSD package includes all data needed to restore the PSD to its last known state when it is next loaded into a cryptographic module. This includes the items that the IBIP specifications require to be stored inside the PSD, information required to return the PSD to a valid state when the record is reloaded from the database, and data needed for record security and administrative purposes.

15 In one embodiment, the items included in a PSD package include ascending and descending registers (the ascending register "AR" records the amount of postage that is dispensed or printed on each transaction and the descending register "DR" records the value or amount of postage that may be dispensed and decreases from an original or charged amount as postage is printed.), device ID, indicia key certificate serial number, licensing ZIP code, key token for the
20 indicia signing key, the user secrets, key for encrypting user secrets, data and time of last transaction, the last challenge received from the client, the operational state of the PSD, expiration dates for keys, the passphrase repetition list and the like.

As a result, the need for specific PSDs being attached to specific cryptographic modules is eliminated. A Postal Server subsystem provides cryptographic module management services
25 that allow multiple cryptographic modules to exist and function on one server, so additional cryptographic modules can easily be installed on a server. The Postal Sever subsystem is easy to scale by adding more cryptographic modules and using commonly known Internet load-balancing techniques to route inbound requests to the new cryptographic modules.

30 Referring back to FIG. 1, Postage servers 109 includes one or more Postal servers and provide indicia creation, account maintenance, and revenue protection functionality for the on-line postage system. The Postage servers 109 include several physical servers in several distinct logical groupings, or services as described below. The individual servers could be located within one facility, or in several facilities, physically separated by great distance but connected by secure communication links.

35 Cryptographic modules 110 are responsible for creating PSDs and manipulating PSD data to protect sensitive information from disclosure, generating the cryptographic components of the digital indicia, and securely adjusting the user registration. When a user wishes to print VBI, for example, postage or purchase additional VBI or postage value, a user state is instantiated in

1 the PSD implemented within one of the cryptographic modules 110. Database 111 includes all
the data accessible on-line for indicia creation, account maintenance, and revenue protection
processes. Postage servers 109, Database 130, and cryptographic modules 110 are maintained
in a physically secured environment, such as a vault.

5 FIG. 2 shows a simplified system block diagram of a typical Internet client/server
environment used by an on-line postage system in one embodiment of the present invention. PCs
220a-220n used by the postage purchasers are connected to the Internet 221 through the
communication links 233a-233n. Each PC has access to one or more printers 235. Optionally,
as is well understood in the art, a local network 234 may serve as the connection between some
10 of the PCs, such as the PC 220a and the Internet 221 or other connections. Servers 222a-222m
are also connected to the Internet 221 through respective communication links. Servers 222a-
222m include information and databases accessible by PCs 220a-220n. The on-line VBI system
of the present invention resides on one or more of Servers 222a-222m.

15 In this embodiment, each client system 220a-220m includes a CPU 223, a keyboard 224,
a mouse 225, a mass storage device 231, main computer memory 227, video memory 228, a
communication interface 232a, and an input/output device 226 coupled and interacting via a
communication bus. The data and images to be displayed on the monitor 230 are transferred first
from the video memory 228 to the video amplifier 229 and then to the monitor 230. The
communication interface 232a communicates with the servers 222a-222m via a network link
20 233a. The network link connects the client system to a local network 234. The local network
234 communicates with the Internet 221.

25 In one embodiment, a customer, preferably licensed by the USPS and registered with an
IBIP vendor (such as Stamps.com), sends a request for authorization to print a desired amount
of VBI, such as postage. The server system verifies that the user's account holds sufficient funds
to cover the requested amount of postage, and if so, grants the request. The server then sends a
cryptographically authenticated response specifying the VBI to the client system. The client
system then sends image information for printing of a postal indicium for the granted amount to
a printer so that the postal indicium is printed on an envelope or label.

30 In one embodiment, when a client system sends a VBI print request to the server system,
the request needs to be authenticated before the client system is allowed to print the VBI, and
while the VBI is being printed. The request is cryptographically authenticated using an
authentication code. The client system sends a password (or passphrase) entered by a user to the
server for verification. If the password fails, a preferably asynchronous dynamic password
verification method terminates the session and printing of the VBI is aborted. Also, the server
35 system communicates with a system located at a certification authority for verification and
authentication purposes.

In one embodiment, the information processing components of the on-line postage system
include a client system, a postage server system located in a highly secure facility, a USPS system

1 and the Internet as the communication medium among those systems. The information processing equipment communicates over a secured communication line.

Preferably, the security and authenticity of the information communicated among the systems are accomplished on a software level through the built-in features of a Secured Socket Layer (SSL) Internet communication protocol. An encryption hardware module embedded in the server system is also used to secure information as it is processed by the secure system and to ensure authenticity and legitimacy of requests made and granted.

The on-line VBI system does not require any special purpose hardware for the client system. The client system is implemented in the form of software that can be executed on a user computer (client system) allowing the user computer to function as a virtual VBI meter. The software can only be executed for the purpose of printing the VBI indicia when the user computer is in communication with a server computer located, for example, at a VBI meter vendor's facility (server system). The server system is capable of communicating with one or more client systems simultaneously.

In one embodiment of the present invention, the cryptographic modules 110 are FIPS 140-1 certified hardware cards that include firmware to implement PSD functionality in a cryptographically secure way. The cryptographic modules are inserted into any of the servers in the Postal Server Infrastructure. The cryptographic modules are responsible for creating PSDs and manipulating PSD data to generate and verify digitally signed indicia. Since the PSD data is created and signed by a private key known only to the module, the PSD data may be stored externally to the cryptographic modules without compromising security.

FIG. 3 is a block diagram of an exemplary cryptographic module. Processor 302 is electrically coupled to the RAM 303, NVM 304, ROM 305. I/O interface 307, Random Number Generator (RNG) 308, Cipher Engine 310, and Clock 309 through the bus 301. NVM 304 and ROM 305 are protected from unauthorized access by the Hardware Locks control 306. A Security sensing & Response (SSR) circuit 311 detects any attempts to tamper with the module and acts accordingly. The SSR circuit includes sensors to protect against attacks involving probe penetration, power sequencing, radiation, temperature manipulation, and the like, consistent with some security standards, such as FIPS 140-1 Level 3 and 4 requirements. If the tamper sensors are triggered, the cipher Engine 310 resets its critical keys, destroys its certification, and is rendered inoperable.

Initially, the module generates a unique key pair, which is stored in the secured NVM. The tamper detection circuitry is activated at this time and remains active throughout the useful life of the module, protecting this private key, as well as all other keys and sensitive data. The module's private key is certified by a private key and the certificate is retained in the module. Subsequently, the module's private key is used to sign module status responses which, in conjunction with a series of public key certificates, demonstrates that the module remains intact and is genuine. As a result, only the software that has been signed by an entity trusted by the

1 module (via the embedded public key) will be loaded.

2 Cipher Engine 310 supports multiple custom cryptographic engines and other accelerated
3 state machines to provide complex and numerically intensive operations required for encryption/
4 decryption, authentication, and key management. RNG 308 generates the required data for the
5 Cipher Engine. Clock & Calender circuit 309 generates real-time clock and calender for the
6 Cipher Engine and the I/O interface 307 provides interface to other devices on a computer
7 network.

8 In one embodiment, Cipher Engine 310 includes the following logical elements:

- 9 • A DES Engine including the following features:
 - 10 • DES, Triple DES, MAC and Triple-DES MAC functions
 - 11 • Electronic codebook (ECB) support and cipher block chain (CBC) modes of
12 operation
 - 13 • 3 internal 64-bit key registers loaded from a ISA port
 - 14 • 64-bit initial vector register loadable from a ISA port
 - 15 • 64-bit input & output registers readable from both a 16-bit ISA port or a 32-bit PCI
16 add-on port via the output FIFO
 - 17 • Optional DES assist for data padding of data blocks which are not multiples of 64-
18 bytes

19 A SHA Engine including the following features:

- 20 • SHA-1 secure hash algorithm
- 21 • Four 32-bit K registers with fast initialization to FIPS-180 Constants via an ISA
22 port accessible control register
- 23 • Five 32-bit H registers with fast initialization to FIPS-180 initial values by an ISA
24 port accessible control register. Hashing data loadable into H registers via the 16-
25 bit ISA port or the 32-bit PCI add-on port and input FIFO. Hash results readable
26 from five 32-bit H registers via ISA port.
- 27 • Five internal registers for SHA-1 hash results creation
- 28 • SHA engine exercises FIPS 180-1 algorithm. Digital Signature Standard FIPS
29 PUB-186 pseudo random number creation possible by programming K constants
30 and H initialization vector registers via the ISA bus input.

31 A RSA Engine capable of performing the following modular arithmetic and
32 exponentiation functions for high speed RSA encryption:

35

1

Modular Exponentiation With CRT (chinese remainder theorem)	$R=A^{(B_p, B_q)} \bmod (N_p, N_q)$
Modular exponentiation	$R=A^B \bmod N$
Modular multiplication	$R=(A*B) \bmod N$
Modular addition	$R=(A+B) \bmod N$
Addition	$R=(A+B)$
Subtraction	$R=(A-B)$
2's complement	$R=\sim A+1$
Signature	$R=A^B \bmod N; \text{if}(2R \geq N) R=N-R$
Verify	$R=A^B \bmod N; \text{if}(\text{mod } 16 \neq 6) R=N-R$

5

10

15

The RSA engine is a 2048-bit engine with the following registers:

Operand Register	Length (bits)	Contents
A	2048	Data
B	2048	Exponent
B _p	1088	CRT Mod Expo. only
B _q	1024	CRT Mod Expo. only
N	2048	Module
N _q	1088	CRT Mod Expo. only
N _p	1024	CRT Mod Expo. only
U	1088 (CRT only)	Multiplicative inverse for CRT
R	2048	Results

20

25

30

Registers B₁ B_{p1} B_{q1} N₁ N_{p1} N_q and U are write only from the ISA port of the UltraCypher module.

Register R (results) is read only from the ISA port of the UltraCypher module

Chinese Remainder (CRT) Operands

A = data

B_p = the largest of two odd primes so $N=N_p * N_q$

35

B_q = the smallest of two odd primes so $N=N_p * N_q$

$N_p = B \bmod (N_p - 1)$

$N_q = B \bmod (N_q - 1)$

U = Multiplicative inverse: $N_q^{-1} \bmod N_p$

1 Exponentiation performance can be enhanced by enabling the built-in Chinese Remainder Theorem (CRT) algorithm.

5 In this embodiment, there are ten 16-bit Control, Setup, and Status registers which are written and read via the ISA bus. Some are read only and some are write only from outside of the module. These registers control the data paths and various engines inside of the module and provide information as to the status of the engines and FIFO's.

10 A 64-bit shift register is provided for the collecting of Random data bits generated from outside the module. The external 1-bit input (usually a random noise source) is sampled and loaded into bit-0 of the shift register. The sampling rate is controlled from control register bits which are loaded via the ISA bus. The collected data bits are shifted after each new sampling of data. When the shift register is full of new data an interrupt is generated and the shift register contents may be read from the ISA data port.

15 A 128x32-bit Input FIFO and a similar Output FIFO is provided in the module to buffer a PCI Add-on bus.

INPUT FIFO Inputs	INPUT FIFO Outputs	OUTPUT FIFO Inputs	OUTPUT FIFO Outputs
PCI add-on bus	DES engine	DES engine	PCI add-on bus
ISA bus	SHA-1 engine	ISA bus	ISA bus
	OUTPUT FIFO	INPUT FIFO	
	ISA bus		

25 A multipurpose 16-bit data interface supports an ISA 16-bit cycles. Addressing of the module's internal registers is via the ISA address bus. The PCI Add-on bus is capable of supporting PCI bus master. There are also 8 IRQ interrupt outputs, reset, other control lines, clock I/O.

The cryptographic module of the present invention may be embodied in a single-chip module, a multi-chip embedded module, a multi-chip standalone module, embedded in software running on a computer such as a personal computer, or the like.

30 The on-line VBI system is based on a client/server architecture. Generally, in a system based on client/server architecture the server system delivers information to the client system. That is, the client system requests the services of a generally larger computer. In one embodiment, the client is a local personal computer and the server is a more powerful group of computers that house the information. The connection from the client to the server is made via a Local Area Network, a phone line or a TCP/IP based WAN on the Internet. A primary reason
35 to set up a client/server network is to allow many clients access to the same applications and files stored on the server system.

In one embodiment, Postage servers 109 include a string of servers connected to the

1 Internet, for example, through a T1 line, protected by a firewall. The firewall permits a client to
communicate with a server system, only if the information packet transmitted by the client system
complies with a security policy set by the server system. The firewall not only protects the
system from unauthorized users on the Internet, it also separates the Public Network (PUBNET)
5 from the Private Network (PRVNET). This ensures that packets from the Internet will not go to
any location but the PUBNET. The string of servers form the different subsystems of the on-line
postal system. The services provided by the different subsystems of the on-line postage system
are designed to allow flexibility and expansion and reduce specific hardware dependancy.

The Database subsystem is comprised of multiple databases. FIG. 4 illustrates an
10 overview of the on-line VBI system which includes the database subsystems. Database 411
includes the Affiliate DBMS and the Source IDs DBMS. The Affiliate DBMS manages affiliate
information (e.g., affiliate's name, phone number, and affiliate's Website information) that is
stored on the Affiliate Database. Using the data from this database, marketing and business
reports are generated. The Source IDs Database contains information about the incoming links
15 to the vendor's Website (e.g., partners' information, what services the vendor offers, what
marketing program is associated with the incoming links, and co-branding information). Using
the data from this database, marketing and business reports are generated.

The Online Store Database 412 contains commerce product information, working orders,
billing information, password reset table, and other marketing related information. Website
20 database 410 keeps track of user accesses to the vendor website. This database keeps track of
user who access the vendor website, users who are downloading information and programs, and
the links from which users access the vendor website. After storing these data on the Website
Database 410, software tools are used to generate the following information:

- Web Site Status
- 25 • Web Site Reports
- Form Results
- Download Successes
- Signup, Downloads, and Demographic Graphs
- Web Server Statistics (Analog)
- 30 • Web Server Statistics (Web Analyzer)

Offline database 409 manages the VBI (e.g., postal) data except meter information, postal
transactions data, financial transactions data (e.g., credit card purchases, free postage issued, bill
credits, and bill debits), customer marketing information, commerce product information, meter
license information, meter resets, meter history, and meter movement information. Consolidation
35 Server 413 acts as a repository for data, centralizing data for easy transportation outside the vault
400. The Consolidation Server hosts both file and database services, allowing both dumps of
activity logs and reports as well as a consolidation point for all database data.

1 The Offline Reporting Engine MineShare Server 415 performs extraction transformation
from the holding database that received transaction data from the Consolidated Database
(Commerce database 406, Membership database 408, and Postal Database 407). Also, the
Offline Reporting Engine MineShare Server handles some administrative tasks. Transaction data
5 in the holding database contains the transaction information about meter licensing information,
meter reset information, postage purchase transactions, and credit card transactions. After
performing extraction transformation, business logic data are stored on Offline Database 409.
Transaction reports are generated using the data on the Offline Database. Transaction reports
contain marketing and business information.

10 The Data Warehouse database 414 includes all customer information, financial
transactions, and aggregated information for marketing queries (e.g., how many customers have
purchased postage). In one embodiment, commerce Database 406 includes a Payment Database,
an E-mail Database, and a Stamp Mart Database. The E-mail DBMS manages access to the
contents of e-mail that were sent out to everyone by vendor servers. The Stamp Mart database
15 handles order form processing. The E-commerce Server 404 provides e-commerce related
services on a user/group permission basis. It provides commerce-related services such as
payment processing, pricing plan support and billing as well as customer care functionality and
LDAP membership personalization services.

20 A Credit Card Service is invoked by the E-commerce Server 404 to authorize and capture
funds from the customer's credit card account and to transfer them to the vendor's merchant
bank. A Billing Service is used to provide bills through e-mail to customers based on selected
billing plans. An ACH service runs automatically at a configurable time. It retrieves all pending
ACH requests and batches them to be sent to bank for postage purchases (i.e. money destined for
the USPS), or Chase for fee payments which is destined for the vendor account.

25 The E-commerce DBMS 406 manages access to the vendor specific Payment, Credit Card,
and Email Databases. A Membership DBMS manages access to the LDAP membership directory
database 408 that hosts specific customer information and customer membership data. A Postal
DBMS manages access to the Postal Database 407 where USPS specific data such as meter and
licensing information are stored. A Postal Server 401 provides secure services to the Client,
30 including client authentication, postage purchase, and indicia generation. The Postal Server
requires cryptographic modules to perform all functions that involve client authentication,
postage purchase, and indicia generation.

35 Postal Transaction Server 403 provides business logic for postal functions such as device
authorization and postage purchase/register manipulation. The Postal Transaction Server requires
the cryptographic modules to perform all functions. There are four Client Support Servers.
Address Matching Server (AMS) 417 verifies the correct address specified by a user. When the
user enters a delivery address or a return address using the Client Software, the user does not
need the address matching database on the user's local machine to verify the accuracy of the

1 address. The Client software connects to the vendor's server and uses the central address
database obtained from the USPS to verify the accuracy of the address. If the address is
incorrect, the client software provides the user with a prioritized list of addresses to match the
correct address. These choices are ranked in a user definable order. This information is
5 represented using a plain text format.

The Client Support Servers 417 provides the following services: a Pricing Plan service,
an Auto Update service, and a Printer Config service. The Pricing Plan Service provides
information on pricing plans and payment methods available to the user. It also provides what
credit cards are supported and whether ACH is supported. This information is represented
10 preferably using a plain text format. The Auto Update Service verifies whether the user is
running the latest Client Software. If there is newer Client Software, the Auto Update Server
downloads the new patches to the user computer. The Client Support Database has tables for the
client software update information. This information is represented using a plain text format.

Before the user tries to print postage, the user sends his or her printer driver information
15 over the Internet in plain text. The Printer Config Service looks up the printer driver information
in the Printer Driver Database to determine whether the printer driver is supported or not. When
the user tries to configure the printer, the user prints a test envelope to test whether the postage
printing is working properly or not. This testing envelope information is sent over the Internet
in plain text and is stored in the Client Support Database.

20 MeterGen server 422 makes calls into the cryptographic module to create sufficient meters
to ensure that the vendor can meet customer acquisition demands. SMTP Server 418
communicates with other SMTP servers, and it is used to forward e-mail to users. Gatekeeper
Server works as a proxy server by handling the security and authentication validation for the
smart card users to access customer and administration information that reside in the vault.

25 The Proxy Server 423 uses the Netscape™ Enterprise SSL library to provide a secure
connection to the vault 400. Audit File Server 419 acts as a repository for module transaction
logs. The Audit logs are cryptographically protected. The Audit File Server verifies the audit
logs that are digitally signed. The audit logs are verified in real time as they are being created.
Postal Server writes audit logs to a shared hard drive on the Audit File Server. After these logs
30 are verified, the Audit File Server preferably moves them from the shared hard drive to a storage
device that is not shared by any of the vendor servers. Provider Server provides reporting
and external communication functionality including the following services. CMLS Service
forwards license applications and it processes responses from CMLS. The CMLS Service uses
cryptographic functions provided by the Stamps.com Crypt library to decrypt the user's SSN/Tax
35 ID/Employee ID. CMRS Service reports meter movement and resetting to the USPS
Computerized Meter Resetting infrastructure. ACH Service is responsible for submitting ACH
postage purchase requests to the USPS lockbox account at the bank. The CMLS Service uses
cryptographic functions to decrypt the user's ACH account number.

1 After decrypting ACH account information, the ACH is encrypted using the vendor's script library. Then, the encrypted ACH file is e-mailed to the Commerce Group by the SMTP server. When the Commerce Group receives this encrypted e-mail, the vendor's Decrypt utility application is used to decrypt the ACH e-mail. After verifying the ACH information, the
5 Commerce Group sends the ACH information through an encrypted device first and then uses a modem to upload the ACH information to a proper bank. The Certificate Authority issues certificates for all IBIP meters. The certificates are basically used to provide authentication for indicia produced by their respective meters.

 The following are exemplary steps describing the certificate authorization process:

- 10 • MeterGen asks the module to create a meter package,
- The module returns a package and the meter's public key,
- MeterGen creates a certificate request with the public key, signs the request with a USPS-issued smartcard, and submits the request to the USPS Certificate Authority,
- The Certificate Authority verifies the request came from the vendor then, it creates a new
15 certificate and returns it to MeterGen,
- MeterGen verifies the certificate using the USPS Certificate Authority's certificate (e.g., to ensure it wasn't forged) and stores the certificate information in the package. The package is now ready to be associated with a customer.

 The Postal Server subsystem 401 controls client and remote administration access to
20 server functionality, authenticates clients and allows clients to establish a secure connection to the on-line postage system. The Postal Server subsystem also manages access to USPS specific data such as PSD information and a user's license information. The Postal Server subsystem queries the Postal portion of the Database subsystem for the necessary information to complete the task. The query travels through the firewall to the Postal portion of the Database subsystem.
25 The Postal Server subsystem is the subsystem in the Public Network that has access to the Database subsystem.

 In one embodiment of the present invention, Postal Server 401 is a standalone server process that provides secure connections to both the clients and the server administration utilities, providing both client authentication and connection management functionality to the system.
30 Postal Server 401 also houses postal-specific services that require high levels of security, such as purchasing postage or printing indicia. Postal Server 401 is comprised of at least one server, and the number of servers increases when more clients need to be authenticated, are purchasing postage or are printing postage indicia.

 The growth in the number of servers of the Postal Server will not impact the performance
35 of the system since the system design allows for scalability. The Postal Server is designed in such a way that all of the business logic is processed in the servers and not in the database. By locating the transaction processing in the servers, increases in the number of transactions can be easily handled by adding additional servers. Also, since each transaction is stateless (the

1 application does not remember the specific hardware device the last transaction utilized),
multiple machines can be added to each subsystem in order to handle increased loads. In one
embodiment, load balancing hardware and software techniques are used to distribute traffic
among the multiple servers.

5 Typically, the security requirements of an online VBI system entail protections of two
basic types: Logical and Physical, or both. Logical protections employ cryptographic techniques
involving encryption algorithms and authentication processes. Physical security measures are
required to prevent undetected tamper and to protect stored critical data from unauthorized
access, modification or destruction. The PSD functionality and data are to be protected by the
10 cryptographic modules.

For the embodiment that includes printing postage, system functional requirements are
based on the IBIP specifications. The PSD is preferably located at a central location (for
example, the Internet server) and may service multiple clients. The PSD's functions include
client authorization (assignment of a "meter" to a client), postage register arithmetic operations,
15 creation and printing of a valid postage, messages between the provider infrastructure and PSD,
and the like.

The following functional security objectives are achieved by the cryptographic module
according to one aspect of the present invention:

- 20 • preventing unauthorized and undetected modification of data, including the unauthorized
modification, substitution, insertion, and deletion of postage related data and
cryptographically critical security parameters;
- preventing the unauthorized disclosure of the non-public contents of the postage meter,
25 including plaintext cryptographic keys and other critical security parameters;
- ensuring the proper operation of cryptographic security and postage related meter
functions;
- detecting errors in the operation of security mechanisms and to prevent the compromise
30 of meter data and critical cryptographic security parameters as a result of those errors;
- providing indications of the operational state of the postage meter; and
- employing generally accepted security methods for the protection of the meter and
35 cryptographic module, and their contents.

The cryptographic module is capable of supporting authorized roles and the corresponding
services that can be performed within those roles. Since the module can support multiple
concurrent operators, the module internally maintains the separation of the roles and services

1 performed by each operator. Furthermore, a cryptographic module is used to employ access control mechanisms to authenticate an operator accessing the module (either directly or indirectly via a computer process acting on his or her behalf) and to verify that the operator is authorized to assume the desired role and to perform the desired services within that role.

5 In one embodiment, the roles supported by the module includes the following roles:

- Security Officer role initiates key management functions, including import, export, activation and de-activation of keys.
- 10 • Key Custodian role takes possession of (encrypted) shares of keys during key export and enter them during key import.
- Administrator role manages the user access control database.
- Auditor role manages (views, saves, archives, and deletes) audit logs.
- 15 • Provider role transmits signed messages to the PSD's for postage refilling and other provider functions.
- User role performs the expected IBIP postal meter operations.
- 20 • Certificate Authority role allows the PSD's public key certificate to be loaded and verified.

Access to the first four of the above listed roles is preferably obtained by logging on from a computer connected to the cryptographic module. Software applications on the computer and in the module first establish a secure communications channel (a session). A session master key is established using a NIST approved protocol, for example, anonymous unauthenticated Diffie-Hellman key exchange. The Diffie-Hellman system parameters, p and q , are embedded in the software of the module and the associated computer. Because the Diffie-Hellman protocol is vulnerable to certain attacks, preferably, the computer and the module are isolated from the LAN whenever a secure session is required. The master key is then used to derive transaction keys (for MACing and encrypting) that are changed after each message is transmitted.

Once the secure session with the module is established, the entities logging on can input their names and passphrases to provide identity based authentication for the selected role. During the initializing state of the module, access control data for the entity that will assume the administrator role is entered in a module access control database. This allows the administrator to log on and enter access control data for all other entities who will require access to the module.

35 The confidentiality requirement in FIPS 140-1 mandates encryption of all sensitive security parameters, including passwords. The cryptographic module of the present invention

1 establishes the session and its security services first, and then transmits the password over the encrypted (and authenticated) channel.

The user passphrase as typed on the keyboard is hashed by the host machine and the module only has knowledge of the hash value. In the remainder of this document, the hashed
5 passphrase as used to get access to the module is called the password.

Preferably, there is no operational requirement to have more than one user logged on at the same time, or to have users with more than one role. This is desirable because of separation of duties. In one embodiment, for each action that is requested, the access control makes it clear which user requested it, and what his role(s) is (are). This holds irrespective of whether the
10 request is granted or denied. This would be difficult to achieve if more than one user is logged on at the same time.

Certain roles have disjoint sets of authorized commands. For example, an Auditor is not authorized to perform any operational or key management related commands. While it is possible to check that a user does not possess certain roles as well as verifying that he does
15 possess another role (e.g., verify that the user is *not* an Administrator, and is a Security Officer), this would complicate the code and the design. A more elegant and foolproof method is to disallow users to hold multiple roles. If one physical user ever has to have more than one role, an easy solution is to provide multiple accounts for this user, one account for each role.

In one embodiment, for each user, the following user profile data is maintained inside the
20 module, in permanent storage:

- Username (User ID, UID)
- User Role (Role ID, RID)
- Password (hashed passphrase)
- Logon failure count
- 25 • Logon failure limit
- Logon time-out limit
- Account expiration
- Password expiration
- Password period (the period for which password validity is granted when changing
30 it).

The following functions are provided for access management:

- Initialization of the access control database.
- Begin Admin (transition to Administrative state).
- End Admin (transition back to Operational state).
- 35 • Creation of an account.
- Deletion of an account.
- Modification of an account.
- Viewing the access control database. This command lists all users and their roles,

- 1 account expiration, last access, but (of course) not the user passwords.
- Logon.
 - Logoff.
 - Query Current User Role.
 - 5 • Query Current User ID.
 - Change password.
 - Set the internal module clock.
 - Get Status.

10 The initialization of the access control database creates the minimal set of users required by the module. This set includes one Administrator, one Security Officer and at least two Key Custodians. This command is the first command in Initializing state, as all other commands require one of these users. Creation, deletion and modification of an account and access control database and setting the internal module clock are restricted to users with Administrator role, in Administrative state only. Administrative state is entered by the Start Admin command, issued
15 by a Security Officer in Operational state.

All sensitive Administrative commands are collected in Administrative state and require Administrator user role. This separation of roles ensures dual control. Secondly, the transition to Administrative state will ensure that no operational commands can be issued by the Administrator (separation of duties). Finally, Administrative state can only be reached from
20 Operational state, ensuring that initialization of the module has been completed successfully before any administrative command can be issued. The End Admin command causes the module to transition back to Operational state.

Preferably, the cryptographic module only allows one session to be established at a time. After authenticating to select a role, the entity can then issue any command that is available to
25 that role. Preferably, meter users are authenticated on a command-by-command basis. During the user registration process, a DES MAC key, generated by the client cryptographic software, is transmitted to the module and is stored in the client's PSD package. Each command from a user that requests PSD services is DES MAC'ed with his personal DES MAC key which allows the module to authenticate the user. Many clients can be simultaneously connected to the
30 transaction server and the module(s) will respond to their requests for service as each request is received from a client.

The provider is authenticated on a command-by-command basis. Provider messages are signed using DSA. The signature is verified using the public key which is loaded into the module when it is initialized for postal operation. The certificate authority role is authenticated by using
35 the Certificate Authority ("CA") certificate to verify the signature on the PSD's public key certificate. In one embodiment, the module implements identity based authentication for all roles which meets the requirements of FIPS 140-1, level 3, in the area of roles and services.

In one embodiment of the present invention, the cryptographic module is implemented

1 within an IBM 4758 cryptographic Coprocessor to securely print VBIs. The IBM 4758 to
provides a set of cryptographic hardware and software within a protective enclosure that could
be customized through additional software development. The IBM 4758 specification is
described in "Building a High-Performance, Programmable Secure Coprocessor," S.W. Smith
5 and S. Weingart, IBM T.J. Watson Research Center, February 17, 1998; and "IBM 4758
Cryptographic Coprocessor Specification," available on IBM's website (www.IBM.com), the
contents of which are hereby incorporated by reference herein.

The module's software is divided into four separately controlled layers. Software layers
zero and one allow the module to initialize itself after power up, run self-tests, and include
10 functions to cryptographically authenticate software loaded into layers two and three. The 4758
module, including the software of layer zero and one, has received a Security Level 4 certificate
from NIST. In this embodiment, the present invention is implemented by developing a new and
proprietary crypto service and postal application software for installation in layer three.

FIPS 140-1 cryptographic security requirements are graded into four levels of increasing
15 security and assurance. At the transaction server, SSL cryptographic functions may be
implemented with software at security level 1, or may employ a cryptographic module to achieve
a greater level of security. For the cryptographic module of the present invention, security level
3 requirements are specified for each of the applicable FIPS 140-1 security areas, except Physical
Security, which is specified as level 4. The following are brief descriptions of level 3 and level
20 4 security principles.

Level 3 provides for identity-based authentication, which is stronger than the role-based
authentication used in level 2. The module need to authenticate the identity of an operator and
verify that the identified operator is authorized to assume a specific role and perform a
corresponding set of services.

25 Level 3 also provides stronger requirements for entering and outputting critical security
parameters. The data ports used for critical security parameters need to be physically separated
or logically distinct from other data ports. Furthermore, the parameters need to either be entered
into or output from the module in encrypted form, in which case they may travel through
enclosing or intervening systems, or be directly entered into or output from the module (without
30 passing through enclosing or intervening systems) using split knowledge procedures.

Level 3 allows software cryptography in multi-user, timeshared systems when a trusted
operating system is employed along with a trusted path for the entry and output of critical security
parameters. A trusted operating system with a trusted path would have the capability to protect
cryptographic software and critical security parameters from other untrusted software that may
35 run on the system. Such a system could prevent plaintext from being mixed with ciphertext, and
it could prevent the unintentional transmission of plaintext keys.

Security level 4 provides the highest level of security. Level 4 physical security provides
an envelope of protection around the cryptographic module. Whereas, the tamper detection

1 circuits of lower level modules may be bypassed, the intent of level 4 protection is to detect a
penetration of the device from any direction. For example, if one attempts to cut through the
enclosure of the cryptographic module, the attempt is detected and all critical security parameters
are preferably zeroized. Level 4 devices are particularly useful for operation in a physically
5 unprotected environment where an intruder could possibly tamper with the device.

Level 4 also protects a module against a compromise of its security due to environmental
conditions or fluctuations outside of the module's normal operating ranges for voltage and
temperature. Intentional excursions beyond the normal operating ranges could be used to thwart
a module's defense during an attack. A module is required to either include special
10 environmental protection features designed to detect fluctuations or to undergo rigorous
environmental failure testing that provides a reasonable assurance that the module will not be
affected by fluctuations outside of the normal operating range in a manner that can compromise
the security of the module.

The cryptographic modules are capable of being used in a multi-node server based
15 environment. When the transaction server receives a request that requires module services, it
gathers all data required to perform the service and inputs it to a module as part of a module
command. Depending on the service requested, the module may generate outputs such as a
message to the provider infrastructure, a message to the client, or an updated PSD package to be
stored by the database server. The transaction server acts on these module outputs to continue
20 the transaction sequence by relaying messages to the provider, the client, or the database.
Although the server directs the system's operation, the modules and other cryptographic elements
of the system maintain the integrity of data flowing through the system without relying on the
server's software.

Each of the cryptographic modules of the present invention is capable of performing Key
25 management, whether the module implements a secret key (symmetric) algorithm or a public key
(asymmetric) algorithm. Secret keys and private keys are protected from unauthorized disclosure,
modification or substitution. Public keys are protected against unauthorized modification or
substitution. Detailed key management requirements are defined in FIPS 140-1, the contents of
which is incorporated by reference herein. Cryptographic key management is typically concerned
30 with the entire life cycle of the cryptographic keys employed within a cryptographic-based
security system, including their generation, distribution, entry, use, storage, archiving and
destruction.

FIPS 140-1 allows key generation for a cryptographic module to be done either inside the
module or outside the module and then loaded into the module. Because the postage server uses
35 many identical modules to perform the PSD functions, certain keys are generated and distributed
to the other identical modules. All keys are generated using FIPS approved key generation
algorithms, for example the following FIPS approved Standards, the contents of which are hereby
incorporated by reference herein.

- 1 FIPS PUB 46-2: Data Encryption Standard (DES)
 FIPS PUB 46-3: Requirements for 3DES
 FIPS PUB 112: Password Usage
 FIPS PUB 180-1: Secure Hash Standard (SHA-1)
 5 FIPS PUB 186: Digital Signature Standard
 ANSI X9.52-1998 Triple Data Encryption Algorithm Modes of Operation
 PKCS#1: RSA (1024 bits)
 PKCS#3: Anonymous Diffie-Hellman.

10 Each module provides key management support for keys that are used for user data protection. The module is used for the management of a large number of postage meters. Presumably, this number may be too large for (permanent) storage inside the modules. Therefore, all data pertaining to postage meters is stored external to the modules. This necessitates security mechanisms guarded by the module to maintain authenticity and confidentiality of this meter data. In addition, load balancing requires the sharing of the load
 15 between multiple modules. Finally, it is not feasible to predict which module will be processing a certain meter. This leads to the following features:

- Each module supports confidentiality (encryption) and authentication of user data sets when stored outside the module. These keys used for this are called the Master Encryption Key (MEK) and the Master Authentication Key (MAK), respectively.
- 20 • Each module supports encryption and authentication of the key token format: DES (*sccDES_Key_t*), DSA (*sccDSAKeyToken_t*) and RSA (*sccRSAKeyToken_t*), and preferably also generic support for arbitrary-length key data buffers.
- Each module supports generation of Master Keys (MEK and MAK) using the module's hardware-based RNG. Encryption meets FIPS 46-3 requirements for 3DES.
- 25 • Each module provides a backup strategy for Master Keys that maintains security with guaranteed availability under all reasonable circumstances.
- Each module supports activation and de-activation of Master Keys.
- Each module supports rollover from one Master Key Set (MEK and MAK) to another set. This implies support for two Master Key Sets, a active one, and a dormant one. In
 30 addition, each module provides translation of data protected under one of these sets to protection under the other set.
- Each module supports deletion of a (dormant) MKS. This is required in case of compromise of an MKS.

35 Decryption of the data set and verification of its authenticity by another module different than the one that created the encrypted data set is also possible. This implies the requirement of sharing (cloning) of the decryption and authentication keys between modules.

- Export of a Master Key Set (MKS) to another module.
- Import of an MKS from another module.

- 1
- Export and Import of an MKS is encrypted and authenticated.
 - Import and export is under dual control; at least 3 users should be involved.
 - The module that exports an MKS determines whether this MKS is exportable from the importing module.

5 A MKS is generated in the master module. The master module can export an MKS to other modules, in shares, each encrypted under the destination module's Transport Public Key. This process requires prior export of the Transport Public Key from the destination module by a Key Custodian, and provision of that key to the master as an input parameter to the Export Share command. The generation of the Transport Key Pair is done in Initializing state; this
10 command transitions to Importing Shares state. The export of the Transport Public Key is done in Operational or Importing Shares state; the actual import of the MKS is preferably done in Importing Shares state.

The Transport Private Key is a retained key; it can not be exported outside the module it was generated in. This ensures that export of an MKS always is destined for one well-determined
15 module. Generation of a Transport Key Pair only in Initializing state ensures that a module has only one Transport Key Pair in its lifetime; a Reset is required to return to Initializing state. Moreover, transition from Initializing to Importing Shares state upon generation of the Transport Key means that any module should have an MKS when in Operational state.

A MKS can be exported as an exportable MKS or as a retained MKS. This is a property
20 of the exported key itself; the destination module respects this distinction. An exportable MKS can be exported in the same way as the master exports its internally generated key. A retained key cannot be exported (attempted export of a retained MKS will fail). This architecture allows for limitation of the number of modules with an exportable MKS. Unless all of these modules have to be reset, one can always create additional modules with the same MKS. At the same
25 time, there can be fairly tight control over the (few) modules with an exportable MKS.

In case all exportable copies of an MKS are lost (all modules containing an exportable
copy are reset or lost) one can still continue processing with any modules that are still operational. Next, one can create a new MKS (possibly in a new master) and export that to all operational modules. These modules then can roll over to the new key. Subsequently, one can
30 add new modules with this new MKS, like before.

Preferably, all operational modules can be brought back to operational state with the proper MKS as long as at least one exportable copy of this MKS exists. If all exportable copies are lost, one could just continue operating with any remaining operational copies, generate a new MKS in the master (possibly a new module) and roll over to that new MKS in the operational
35 modules. Subsequently, one can create new modules with that MKS, just like before.

This implies that no special backup procedures are required; the cloning procedures and the fact that all exportable copies of an MKS act as each other's backup copy are sufficient to maintain availability under all circumstances that can reasonably be expected to occur.

1 To maximize the probability that at least one exportable copy of the MKS is always
available, an additional MKS backup copy can be created by reserving a separate (non-
operational) module for its storage. To avoid existence of an operational module without
attendance, the import of the MKS is preferably only done when the backup copy is needed.
5 Preferably, the export is done in an n -out-of- m - secret sharing scheme (Shamir).

In the descriptions below for losing keys, the backup shares together with the backup
module are considered to constitute an exportable MKS. Note that the backup module use
requires prior import of n of the m shares.

10 If no exportable copies of the MKS are lost, no capabilities are lost, just operational
capacity (bandwidth). This allows a quick return to full capacity in case a module is lost (see
below), as well as increase of capacity, since the MKS can be exported to a new module.

The recovery procedure is repeated for each of the modules that have lost the MKS.

For a new module or if the transport key is also lost: reset (or replace) the operational
module and generate a new Transport Key Pair in Initializing state;

15 export the Transport Public Key from the destination module;

export encrypted shares of the MKS (for this Transport Public Key) from the source
module;

import the encrypted MKS to the destination module;

activate the MKS in the destination module.

20 If some (but not all) exportable copies of the MKS are lost, the remaining copies can still
export, therefore, no capabilities are lost. (Some capacity may be lost) This allows a quick return
to full capacity by restoring the MKS in all modules that lost it (or in their replacement).

If the only remaining exportable MKS is the backup copy, first import n of the backup
shares into the backup module. This module now is a normal module with an exportable MKS,
25 so the remainder of the procedure is the same as described above. In this case, all operational
modules can continue operating with the current MKS. The only capability lost in this case is
export of the MKS, and therefore the addition of new modules.

The Recovery procedure is as follow:

Reset (or replace) the master;

30 Generate a new MKS in Initializing state;

For each module that is still operational:

Import this module's Transport Public Key;

Export the new MKS from the new master, encrypted under this Transport Public
Key. If the destination module contains a retained copy of the old MKS, the
35 exported MKS should be a retained copy, else it may be an exportable MKS;

Import the new MKS into the operational module;

Translate the protection of all data from the old MKS to the new MKS;

Activate the new MKS in each of the operational modules.

1 This returns the system to a state equivalent to that before loss of all exportable copies of the MKS. In particular, new capacity can now be added again. However, during this recovery, the system has a reduced capacity (only modules that are still operational are running).

5 All keys involved in session key management (ephemeral DH keys, session master keys and transaction keys) are maintained by session management (described below). Local keys are used for encryption of sensitive data stored in persistent memory, to avoid exposure in case of tampering. One mechanism chosen for this is the PPD read/write mechanism for the memory (sccSavePPD and sccGetPPD) where the encryption keys are stored in NVM (which is cleared on tamper). The key management is internal to the module.

10 Key management services related to cloning and management of the MKS include:

- The Key Management Services module interface function
- Generate MKS
- Generate Transport Public Key (TPK)
- Export Transport Public Key
- 15 • Create MKS Shares
- Export MKS Share
- Leave Exporting Shares state
- Start Importing MKS (transition to Importing Shares state)
- Import MKS Share
- 20 • Combine MKS Shares
- Activate MKS (deactivates old MKS, if any, and activates a new one)
- Delete the dormant MKS
- Encryption and/or MAC Translation (decrypt and verify MAC under old MKS; compute MAC and re-encrypt under new MKS)

25 Usage of the MKS include:

- Compute MAC and Encrypt
- Decrypt and verify MAC
- Compute MAC
- Verify MAC

30 The following two keys are generated by a module when the start initialization command is executed. These keys are not shared with other modules.

- ASK, audit signing key. This is a 1024-bit DSA key used to sign entries in an audit log.
- 35 • Audit Verification Public Key. This key is output from the module and will be used to authenticate the audit record log.

The following two keys are generated by a Master cryptographic module when the MKS command is executed.

- MEK, the master encrypting key. This is a triple-DES key used by the module to encrypt

1 all external key tokens for keys that are generated by the modules.

- MAK, the master authentication key. This is preferably an 8-byte key used to generate a DES MAC for key tokens encrypted by the MEK.

5 The following two keys are generated by the modules that are not Masters when the generated transport key command is executed.

- V_TPK, Transport Private Key. This is an RSA key used by a non-master module to decrypt the imported MKS key.
- U_TPK, Transport Public Key. This is an RSA key used by a master module to encrypt an MKS key that will be distributed to another module.

10 The module's system software (CP/Q++) generates the following key during CP/Q++ initialization.

- PPD key. This is a DESkey generated by the CP/Q++ and used to encrypt keys that are stored in the module's flash memory. The key is not accessible outside the system software.

15 The module generates the following keys for use during secure sessions with the host computer.

- Session Master Keys. This is a set of two keys, generated for a given secure session, used to derive session transaction keys. One key is for authentication (DES MAC computation) and the other for security (Triple-DES encryption). The keys are destroyed at the conclusion of the secure session.
- Session Transaction Keys. These keys are used for a single transaction during a secure session. They are derived by a one-way function of the Session Master Keys combined with a transaction counter.

25 The following five keys are generated by a module when the initialize crypto-card command is executed.

- VDSK_ipost, the DSA private key used by the modules to sign challenges during client registration. The key is output in a key token for distribution to other modules.
- 30 • UDSK_ipost, the DSA public key that is imbedded in the client application software and is used to authenticate challenges signed by the module during client registration. The key is output from the module after generation.
- VRSK_ipost, the RSA private key used by the modules to decrypt client secrets transmitted to the modules during client registration. The key is output in a key token for distribution to other modules.
- 35 • URSK_ipost, the RSA public key that is imbedded in the client application software and is used to encrypt client secrets transmitted to the module during client registration. The key is output from the module after generation.

- 1 • MK_chkpt, the DES MAC key used to authenticate a checkpoint database record when it is returned to a module from the database. This key is derived from VDSK_ipost by hashing it using SHA-1 each time that VDSK_ipost is imported by the module.

5 The following keys are generated by a module at the time that a PSD package, the database record containing a postage meter's data, is created.

- V_psd, the DSA private key used to sign indicia created by this VBI meter. This key is stored in the meter's PSD package as a key token, encrypted by the MEK.
- U_psd, the DSA public key used to authenticate the signature on indicia created by this VBI meter. This key is output from the module to the provider after generation.
- MK_psd, the DES MAC key used to authenticate a PSD package when it is returned to a module from the database. This key is derived from V_psd by hashing it using SHA-1 each time that V_psd is imported by the module.
- 15 • EDEK_psd, the 3DES key-encrypting-key used to encrypt the client secrets transmitted to the module during client registration. This key is stored in the client's PSD package as a key token, encrypted by the MEK.

20 FIPS 140-1 allows key distribution to be performed by manual methods, automated methods, or a combination of automated and manual methods. Keys are input to a module when required to initialize the module and to initialize the PSD packages of each meter. These key transfers are not considered key distribution. Also, FIPS 140-1 allows key entry and output procedures to differ depending upon the key distribution technique employed. The cryptographic module does not implement manual key entry. All secret or private keys are input to or output from the module electronically and are encrypted.

25 The system of the present invention utilizes a plurality of cryptographic modules that need to work in concert. This entails creating a shared secret for all the modules. In one embodiment, key entry is required to initialize a new clone module for service at the service provider's facility. Preferably, only one module functions as a master module. The master module generate a Master Key Set (MKS). The exporting of the shares of the MKS keys requires dual control. The Security Officer should first issue a create MKS shares command to specify the number of shares to be created and to authorize the export of the shares.

30 In one embodiment, the module uses a Pseudo-Random Number Generator (PNRG) to generate the MKS, which contains two distinct keys:

- 35 1. Master Encryption Key (MEK): A 3DES key used to encrypt keys when stored outside the module.
2. Master Authentication Key (MAK): This is a key used to compute the DES MAC for signing keys when stored outside of the module.

The MKS is stored in a non-volatile memory (NVM) within the module.

1 When the required number of shares are input to a module, a Key Management Officer
can then enter an export share command to export one of the MKS shares. Input as part of the
export share command is the transport public key of the new module being cloned. This public
key is used to encrypt each key share before it is exported and stored on a storage medium such
5 as a floppy disk, a CDROM, or the like. After the last share is exported, the Master module
returns to the operational state and will no longer output key shares.

For the modules that are not masters, the Security Officer uses the generate transport key
command to request the module to generate the transport key pair. This command also
establishes that the module is not a master module. The transport public key is output for use by
10 a Key Management Officer when exporting MKS key shares from a Master module. To input
MKS shares to a module, the Security Officer must send the start importing shares command to
the destination module. Key Management Officers can then enter their shares from their floppy
disks, CDROMs, or the like until all have been entered. The destination module uses its transport
private key to decrypt the key shares. The process is completed when the Security Officer sends
15 the combine shares command.

The MKS is used to generate external key tokens by MACing the key with the MAK and
Triple-DES encrypting it with the MEK. After a new module has been loaded with the MKS,
the Security Officer can use the initialize crypto-card command to export key tokens from the
module or to load it with key tokens generated by another module.

20 In one embodiment for secure printing of postage values, the following four keys are input
to a module using the initialize crypto-card command.

- VDSK_ipost, the DSA private key used by modules to sign challenges during client
registration.
- VRSK_ipost, the RSA private key used by modules to decrypt client secrets transmitted
25 to the module during client registration.
- U_ca, the USPS Certificate Authority's X.509 certificate.
- UDSK_auth, the DSA public key used to authenticate signatures on messages from the
30 provider infrastructure.

At the time of customer registration, the key URSK_ipost, embedded in the client
computer cryptographic software is used to encrypt client secrets before transmitting them to the
module. These secrets include:

- 35 • HMK, the client's MACing key. The key is used to generate a DES MAC for mutual
authentication of messages between the client and the module.
- PW, the hash of the customer's passphrase. The hash of the passphrase is used to
authenticate the customer to the module if the client's copy of HMK is lost.

1 The module uses the private key VRSK-ipost to decrypt these client secrets before storing
them as an encrypted key token in the meter's PSD package.

5 Within the module, the permanently stored secret keys are stored in designated NVM
locations that serve to adequately identify their function. Secret and private keys that are stored
outside the module as part of a PSD package are contained in key tokens. Key tokens are data
structures that identify the keys and include other information relevant to the keys. The key
tokens are authenticated by the MAK and encrypted by the MEK. When these keys are inside
the module they are stored in designated locations in volatile memory.

10 The cryptographic module of the present invention provides the capability to zeroize all
plaintext cryptographic keys and other unprotected critical security parameters within the module.
For example, the IBM 4758 stores all plain text keys and other SRDI's in BBRAM (NVM).
Zeroization of all BBRAM contents occurs if the module's tamper detection envelope senses
intrusion. A system user can also destroy these SRID's by disconnecting the external batteries
15 that provide backup power to the module. These features allow the 4758 to meet FIPS 140-1
requirements. FIPS 140-1 allows for a cryptographic module to output encrypted keys for
archiving purposes. In one embodiment, each module implements key archiving mechanisms.

20 A state machine determines the availability of module commands in conjunction with the
roles that a user takes up. In other words, the state and the current user role together provide
sufficient information to decide whether an action is allowed or not. Most commands require
authentication for transport from the host to the module. Therefore, an active session is derived
requirement for execution of these commands. This requirement is explicitly verified by these
commands, however.

25 Invalid data may lead to failure of execution. However, verification of validity is
considered the first step in execution. The decision to start execution depends on the state and
the user role alone; validity of input data does not play a role in that decision. The complete
module state or the state of any module application may be composed of the module state as
described in this document, complemented with other state information maintained by other
30 libraries. Exemplary states are described below.

35 Uninitialized state. This is the initial, state that the module is in immediately after loading
the code and booting. No security related data has been loaded. The only available
command is the Start Initializing command.

 Initializing state is the state that the module is in during the initialization process. In this
state, the access control database is initialized and the MKS is generated or its import is
initiated. The module exits this state when an MKS is generated (next state: operational)

1 or when a Transport Key Pair is generated (next state: importing shares).

Operational state. In this state, all normal operational commands can be executed. Depending on the user role(s) these can be administrative (change password), postage
5 meter related, session management or auditing commands. In addition, certain key management commands (activation of a new MKS and deletion of a dormant MKS) are available. Finally, special commands transition to other states (administrative, exporting shares, importing shares) for special restricted commands.

10 Administrative state. This state includes all access control maintenance commands, such as adding, deleting, viewing and modifying user accounts. The module enters this state from Operational state when a Security Officer issues the Begin Admin command in operational state. It remains in this state until the Security Officer issues the End Admin command (next state: operational) .

15 Exporting Shares state. This state allows the Key Custodians to export shares of the MKS. The module enters this state from operational state when a Security Officer issues the Create MKS Shares command. It remains in this state until all shares have been exported (via the Export MKS Share command) or the Abort Export command is issued
20 (in both cases, the next state is operational). If the Abort Export command is issued before all shares are exported, the exported shares may be useless.

Importing Shares state. This state accepts the import of shares of the MKS. The module enters this state from operational state when a Security Officer issues a Start Importing
25 MKS command. It remains in this state until a Combine Shares command is issued (next state: operational if an MKS exists after completion, else error).

30 Error state The coprocessor enters this state on (fatal) errors. Depending on the severity of the error, it should be cleared by rebooting, or the coprocessor should be *reset* (next state: uninitialized). Only audit entry creation and session commands are possible in this state.

FIG. 6 illustrates an exemplary finite state machine. The logon and logoff functions, session management commands, access control queries, and audit entry creation are available in all states except uninitialized and error.

35 Within any thread in the module, it is not possible to interrupt processing, and to resume processing at another instruction than where it was interrupted. The only exception to this rule is rebooting. Rebooting interrupts processing, and starts at a given fixed location in the application.

In one embodiment, two variables hold the current state information: Current State and

1 Persistent State. The latter is stored in NVM. This allows for atomic state transitions and for
retaining state information across rebooting. Atomic state transitions can be implemented by first
updating Current State, then performing all required actions, and finally updating Persistent State.
If the module is rebooted during this sequence, the old state is retained in Persistent State. Thus,
5 if Persistent State has been updated, one is assured that the full transaction has been executed.
In addition, it can be used to retain Error state information as required.

Before executing any function, the module verifies whether a reboot has occurred by
checking a boot detection flag in the NVM. A reboot clears NVM, thus also clearing this flag.
Therefore, the first call to the module after a boot will find this flag cleared. After performing
10 any required initialization, the flag can be set.

Initialization includes the following `boot detection`. When the reboot flag is found
set, no action is taken. When the reboot flag is found cleared, the value of the Persistent State
variable is examined, and the following is done.

If it is Error: a fatal error has occurred, and Current State is set to Error.

15 If it is Initializing: Persistent and Current State are set to Error, as this is a fatal error.

If it is Importing Shares, and if there is no active MKS, Persistent and Current State are
set to Error, as this is a fatal error. (If the module contains a valid active MKS, both
Current State and Persistent State are set to Operational, see below.)

If it is Exporting Shares: Current State is set to Error, as this is a non-fatal error.

20 If it is Uninitialized: no successful initialization has been performed and Current State is
set to Uninitialized.

If it is Importing Shares, and if the module contains a valid active MKS, both Current
State and Persistent State are set to Operational.

Else: both Current State and Persistent State are set to Operational.

25 Unless specified otherwise, all state transitions mentioned in this document are performed
by first updating Current State, and then updating Persistent State. Atomic actions are enclosed
within such a state transition.

The module is in Uninitialized state immediately after loading all software and booting.
In the Uninitialized state, no commands can be accepted, except the "Start Initialization"
30 command. This command erases all non-volatile memory. This erases all data and keys present
in the module, in particular the Master Keys and the access control database; set the internal
module clock; creates the Audit Signing Key; creates the first audit entry, capturing this event;
and transitions to the Initializing state.

35 Preferably, the only way to return to Uninitialized state is to reset the module. This
together with the fact that initialization always erases all data, ensures no data survives a reset.
The Uninitialized state serves as a shield to make sure no transitions to Initializing state are
possible from other states without losing all data and keys.

The Initializing state contains those commands that are to be executed once in the lifetime

1 of a module. The only way to enter Initializing state is by issuing the “Start Initialization” command from the Uninitialized state. This ensures that upon entry to the Initializing state, no data or keys are retained. Here, the module is in an entirely clean state. In Initializing state, the following actions/commands are allowed:

- 5
- Get Status
 - Initialize Access control database
 - Logon
 - Logoff
 - Query Current User Role
 - 10 • Query Current User ID
 - All Session Management commands
 - Audit entry creation
 - Generate Master Key Set
 - Generate Transport Key Pair.

15 The last two commands represent the only means to establish a Master Key Set (MKS) in a module. A module can either generate a Master Key Set (MKS) itself, or it can import one and encrypt it under its own Transport Public Key (TPK). These two commands perform the generation respectively and prepare the import (by generating the import encryption key pair). In summary, the Initializing state serves to initialize the module and the sharing of the MKS.

20 These initializations are one-time activities; the former mainly because there is no need to repeat it; the latter because it is not allowed to happen repeatedly.

All normal, operational commands are executed in Operational state. That is, Operational state contains commands implementing all actions not related to initialization of a module, the maintenance of the access control database, or key management (with the exception of key usage). The following are examples of commands in Operational state associated with different functions.

- 25
- Access Control
 - Begin Admin (transition to Administrative state).
 - Logon
 - 30 Logoff
 - Query Current User Role
 - Query Current User ID
 - View Access control database
 - Change password
 - 35 Set clock
 - Get Status
 - Session Management
 - Open Session

- 1 Close Session
 Compute Session MAC
 Verify Session MAC
 Session Encrypt
 5 Session Decrypt
- Key Management
 - Key management related to cloning and management of the MKS:
 - Export Transport Public Key
 - Start Importing MKS (transition to Importing Shares state)
 - 10 Create MKS Shares (transition to Exporting Shares state)
 - Generate MKS
 - Activate MKS (deactivates old MKS, if any, and activates a new one)
 - Delete dormant MKS
 - Usage of the MKS:
 - 15 Global Encrypt and MAC
 - Global Decrypt and MAC
 - Compute MAC
 - Verify MAC
 - MKS Rollover:
 - 20 Encryption and MAC Translation (decrypt and verify MAC under old MKS;
 compute MAC and re-encrypt under new MKS)
 - Audit Support
 - Audit Entry creation
 - Audit Key Creation
 - 25 Export of the Audit Verification Key
- All administrative commands supporting access control are executed in Administrative state. That is, Administrative state contains commands implementing:
- Creation of an account
 - Deletion of an account
 - 30 • Modification of an account
 - Viewing the access control database. This command lists all users and their roles, account expiration, last access, but not the user passwords.
 - End Admin (transition back to Operational state).
 - Logon
 - 35 • Logoff
 - Query Current User Role
 - Query Current User ID
 - Set clock

- 1
- Get Status
 - All session management commands
 - Audit entry creation.

Preferably, all these commands (except session key usage) are audited.

5 As shown in FIG. 6, Administrative state is entered by the Start Admin command, issued by a Security Officer. The administrative commands in Administrative state require Administrator user role. This separation of roles ensures dual control. Secondly, the transition to administrative state will ensure that no operational commands can be issued by the Administrator (separation of duties).

10 The Exporting Shares state exports encrypted shares of a Master Key Set. When the last share in a secret sharing scheme is exported, the module transitions to operational state. All these commands are audited. (Audit entry creation.) Only an exportable MKS can be exported this way (i.e., internally generated or imported as exportable; by default an imported MKS is a retained key). The export is initiated by a Security Officer issuing the Create MKS Shares

15 command in Operational state. This command changes state to Exporting Shares. The actual export of the encrypted shares is done through the Export Share command, issued by a Key Custodian. Encryption of the shares is under the Transport Public Key. This key is provided by the Key Custodian as an input parameter to the Export Shares command. Rebooting while in

Exporting Shares state may be a fatal error.

20 The following commands are available in the Exporting Shares state.

- Logon
- Logoff
- Query Current User Role
- Query Current User ID

25

- Export Share
- Abort Export
- Get Status
- All Session Management commands
- Audit entry creation.

30 In the Importing Shares state, a module imports encrypted shares of an MKS. The encryption is done under the Transport Key. Importing shares state is entered by Issuing the Start Importing MKS command. The actual import is performed by repeating the Import Share command as required. Combination of the shares to a MKS transitions to Operational state is also possible. All these commands are audited. (Audit entry creation.

35 The following commands are available in the Importing Shares state.

- Logon
- Logoff
- Query Current User Role

- 1 • Query Current User ID
- Export Transport Public Key
- Import Share
- Combine Shares
- 5 • Get Status
- All Session Management commands
- Audit entry creation.

10 In Error state, no cryptographic operations may be performed. Thus, the only commands available in the Error state are Get Status, Access Control Queries. A reset erases all NVM and changes to Uninitialized state. Fatal errors set both Persistent State and Current State to Error. This ensures that rebooting will not clear the error. Therefore, the only way to clear fatal errors is a Reset command, or by a complete re-initialization of the module by other means (both methods change state to Uninitialized). Non-fatal errors only set Current State to Error; the Persistent State is not modified. A subsequent reboot clears the error, unless a boot error occurs.

15 All Module command requests in Error state, with the exception of Get Status, return an error and do not output any data. Error states are preferably non-fatal, with the following exceptions (i.e. these only set Current State to Error):

- failure in Audit Entry Creation which doesn't breaks the audit chain; and
- detection of Exporting Shares state during boot-up

20 Throughout the lifecycle of a module, its software keeps track of the module's present operational state and allows only the operations that are allowed for these module states. Each PSD package also contains information to define its present operational state. When the module is loaded with a PSD's package, module software will only perform operations that are allowed for the present state of that PSD. The following paragraphs describe the states of the module and the PSD package throughout their operating life.

25 When the module is first operated after its software is loaded, it starts in the uninitialized state. Preferably, the only command that it will accept is the start initialization command and the start initialization command will only be executed if the module is in the uninitialized state. During this phase of life, the Module is not considered to be a crypto module and no authentication is required to issue this command. The start initialization command first erases all non-volatile memory to destroy any cryptographic keys or access account database entries that may persist from previous use of the module. When memory erasure is completed, the module transitions to the initializing state.

30 The Initialized state includes commands that can be executed only once in the life of the module. Because this state can only be entered from the uninitialized state, an existing module cannot be modified by using these commands. Within this state the access account database is

35

1 initialized. If a master module is being created, the master key set (MKS) is generated and the operational state is entered. If the module is not a master, the transport key pair is generated and the Importing shares state is entered.

5 Preferably, the module Exporting Shares state can only be entered from the Operational state. Once the master module generates the MKS it can export it to another module. In one embodiment, this is accomplished by using an n of m Shamir secret sharing technique, as follows:

1. A target (clone) module is initialized, following the steps described above.

10 2. The Security Officer logs on to the newly initialized target Module and issues a command to generate a transport key pair (TPK). The TPK is a RSA public key used for transporting an MKS previously generated by the master module. The private portion of the TPK is retained in the new module and can never be exported from the module that generated it. This control ensures that MKS export is always destined for one well-determined target module. The public portion of the TPK is saved on to a floppy disk, a CDROM, or the like.

15 3. The public portion of the TPK is saved onto a storage medium such as a floppy, CDROM, or the like and physically carried over to the machine housing the master module. The Security Officer logs on to the master module and issues the create MKS shares command. The create MKS shares command accepts two arguments: (1) the number of shares to be created (n, one share per key custodian) and (2) the threshold number of shares required to recombine the shares. A successful create MKS command results in n number of shares, where n is greater than or equal to 2.

20 4. A Key Custodian logs in and initiates the export MKS shares command on the master Module and chooses whether the exported key pair should be an exportable or retained key pair for the destination module. An exportable key pair permits the destination module to export key shares in the same manner as the original master module. With a retained key pair, the new cloned module cannot export key shares to other cryptographic modules. The export MKS shares command validates the current key custodian and then encrypts an MKS share with the TPK. The TPK-encrypted share is saved to a floppy, a CDROM, or the like. This procedure is repeated for each key custodian specified in step 3, above.

25 30 35 The module Importing Shares State can be entered from the Initializing state (to load the MKS for the first time) or from the Operational state (to load a replacement MKS). The following describe in more detail the importation of the MKS key shares for generation of the master key set in a module. Once the master Module encrypts the MKS shares and saves them to floppies, the shares can be imported into the target module.

1 1. The Security Officer logs into the target module and initiates the start importing MKS shares command.

5 2. The first Key Custodian inserts their MKS share floppy or CDROM, logs in, and issues the import MKS share command. The target module reads in the first share. This procedure is repeated for each Key Custodian.

10 When the final Key Custodian has finished entering the key share, the Security Officer logs in and issues the combine MKS shares command. The combine MKS shares command causes the target module to unencrypt each share and combine them to create the MKS. The shares are destroyed following this procedure. The MKS is stored in the NVM as described above.

15 Once in the Operational state, the module is capable of completing its remaining initialization steps. The security officer sends an initialize crypto-card command to load all other required module shared keys (These are described in the Key Management section). The administrator can enter the access control data for all other personnel that require authenticated role access to the module.

20 When the module is initialized, it does not become a PSD until PSD packages are created. A PSD package is created using the initialize PSD command. This creates a data structure that contains the PSD package data elements. One data element is the present state of the PSD. The module will only allow the PSD to perform operations that are allowed for its present state. When the initialize PSD process is completed, the PSD state changes to the raw state.

25 In one embodiment, the PSD package for each meter user contains all data needed to restore the meter's PSD to its last known state when it is next loaded into a module. This includes the items that the IBIP Performance Criteria specifies to be stored inside the PSD, information required to return the PSD to a valid state when the record is reloaded from the database, and data needed for record security and administrative purposes. In this embodiment, the PSD package includes the following items:

- Ascending and descending registers
- Device ID
- 30 • Indicia key certificate serial number
- Licensing ZIP code
- Key token for the indicia signing key
- The user secrets, (the client DES MAC key and the SHA-1 hash of the client's passphrase).
- 35 • Key token for EDEK_psd, the key for encrypting user secrets
- Data needed to maintain operating continuity includes:
 - Date and time of the last PSD transaction
 - The last challenge received from the client
 - The operational state of the PSD (leased, withdrawn, etc.)

- 1
- Expiration dates for keys
 - The passphrase repetition list (eliminates reuse of recent passphrases)

5 The IBIP Performance Criteria specifies that the PSD should store the public key certificate for the USPS CA. Because all meters require this information, it serves no purpose to repeat this data in each PSD package. Instead, the certificate for the USPS CA public key is stored in the memory of all the modules.

The following describes the PSD package states.

- 10
- Raw state. As a result of initialization the meter serial number is assigned, the postal registers are set to zero, the PSD keys are generated, and all other initializing steps are performed. The provider receives the PSD public key and device ID needed to obtain the PSD's public key certificate. Preferably, the only command that can be executed while in the raw state is the authorize PSD command.
 - Unleased state. The authorize PSD command loads the PSD public key certificate and changes the PSD state from raw to the unleased state. Preferably, the only command that can be executed while in the unleased state is the configure PSD command.
 - 15 • Assigned state. The configure PSD command assigns the PSD to a customer, allows entry of the customer shared secrets, and places the PSD in the assigned state. When the customer's postal license is issued, the authorize customer command enters the customer's originating zip code and places the PSD in the leased state.
 - 20 • Leased state. Once in the leased state the PSD is ready for the customer to use. The meter can begin printing indicia once the first postage value download had been completed.
 - Password Reset state. This is a temporary state to allow a lost password to be replaced.
 - Withdrawn state. The user's account has been closed or suspended. This state is entered from the leased state or pwreset state by executing the create refund indicium command.
 - 25 The PSD package remains in the database where it can be accessed by the server but after entering the withdrawn state the Module will no longer execute any PSD command when loaded with this PSD package.

30 The PSD packages are stored outside the modules when not being used and the module is able to detect when record storage problems have occurred. In one embodiment, a Redundant Array of Independent Disks (RAID) and a database server are used together to provide reliable operation of the database. Multiple copies of each record are maintained and a locking system is used to prevent more than one postal server from simultaneously accessing one meter's PSD package. If a partial failure of the RAID occurs, the system transparently switches to backup records.

35 In one embodiment, the cryptographic modules store up to five transactions in a respective internal register. The number of transactions compared in the verification process system may be set by the system administrator. A verification process compares a predetermined number of last transactions. The database subsystem stores a table that preferably includes the module(s)

1 present in the Postal Server subsystem, the module serial numbers, the time of the last transaction
 the module processed, the date of the last transaction the module processed and the value of the
 last transaction the cryptographic module processed. Other values related to a transaction and
 a module can also be saved for verification purposes. An example of the module table, where
 5 the Postal Server subsystem has four modules, is illustrated below.

Cryptographic module	Cryptographic module Serial. #	Transaction Time	Transaction Date	Transaction Value
1	34576590	11:53 PM	08/06/99	\$ 0.33
2	34582152	07:30 AM	08/05/99	\$ 7.55
3	34593104	03:00 PM	08/02/99	\$ 3.45
4	34593992	11:22 AM	08/03/99	\$ 5.78

15 When a cryptographic module loads a new PSD out of the Database subsystem
 (performing a transaction), the module's register, containing the last transaction's time, date and
 value, is verified against that module's entry in the Database subsystem's module table. The
 time, date or value for each transaction stored in each module should match the corresponding
 values for the respective module stored in the database for the verification process to be
 20 successfully completed. Cryptographic modules do not load new PSD transactions unless the
 verification process has been successfully completed. If any of the compared values is found to
 be different, preferably the whole system shuts down until authorized personnel can investigate
 the situation. In one embodiment, the threshold in the system is adjustable so that the system
 may be set to shut down if one, two or more modules fail the verification process.

25 With the success of the authorization state, the client software not only trusts the
 cryptographic module, but also shares a common HMK with the cryptographic module, which
 it uses to sign and challenge each successive message. FIG. 5 is an exemplary embodiment
 illustrating client software and cryptographic module (PSD) communication during the
 operational state. Client software 503 sends a new challenge message to cryptographic module
 30 502, as shown by 501. The cryptographic module responds by signing the challenge with the
 shared HMK and then sends this ciphertext back to the client software, along with its own
 challenge, as shown by 504. Client software 503 compares the ciphertext of the challenge it
 originally sent to the cryptographic module, and also signs the message received from the
 cryptographic module.

35 If the signatures compare, the client software trusts the cryptographic module for this
 transaction. Client software 503 uses the cryptographic module challenge message to

1 authenticate itself to cryptographic module 502. Client software 503 now sends the signed challenge that cryptographic module 502 had sent, with the addition of the client software local record of the user's AR and DR, as shown by 505.

5 The client software also sends a cleartext of the challenge and the transaction message, as shown by 506. Next, the client software sends a Hash Message Authentication Code (HMAC) for all of the data sent in 505 and 506, using shared HMK, as shown by 507. HMAC is a digital signature created using a hash algorithm with an arbitrary message and the secret key (HMK). The client software sends the original arbitrary message and the HMAC to Postal Server via the network. HMK, as the HMAC Key, stays in the client software 503. The cryptographic module 10 502 already has a copy of HMK because it was sent over to Postal Server during the user registration process. In another embodiment, Data Encryption Standard Message Authentication Code (DES MAC) is used instead of HMAC.

15 In one embodiment, the checkpoint concept operates in the following manner. Each module retains in its memory records relating to the three most recent transactions that modified a PSD package. For example, these records include the following data items:

- PSD meter ID
- Transaction type
- Transaction amount
- PSD AR value
- 20 • PSD DR value
- Module serial number
- Date/time stamp (for record replay detection)
- Module total amount reset
- Module total amount printed
- 25 • Module total amount refunded

30 The record of the most recent transaction is also output to the database and is protected from modification by a DES MAC generated using the key HMK_chkpt. When a PSD transaction is to be performed, the checkpoint record from the database is input along with the PSD package for the meter. Preferably, all IBIP commands to the modules are handled by the function sdx_dispatch. Within dispatch, the checkpoint record from the database is compared with the most recent checkpoint record stored in the module memory. If they match, it is highly likely that no switchover of the database (resulting in lost records) has occurred. The module then trusts that the PSD package is up to date and allows the IBIP command to be executed. When the IBIP command is completed, the checkpoint record is updated and output to the server 35 for database storage along with the updated PSD package.

In the case of create indicium commands, the server first confirms that the updated records have been stored on the database before the indicium is transmitted to the client for printing. (Server transaction logs keep a record of all messages sent to clients.) In the case of the provider

1 commanding postage value download or create refund indicium, the server reports an error if the database fails to correctly store the updated checkpoint record and PSD package.

If the comparison of internal and external checkpoint records does not match, the module will not execute the IBIP command and an error code is returned to the server. The server then sends a command called "Auto-Recover module Checkpoint" to the module. This command allows a controlled rollback to an older checkpoint if the external checkpoint record matches either of the two older checkpoint records stored in the module internal memory. The module updates its internal records using data from the accepted checkpoint and outputs audit log records to document the more recent PSD transactions that are to be discarded (transactions more recent than the accepted checkpoint). If none of the module's internal checkpoint records match the record input from the database, auto-recovery fails and an error is returned to the server. This module is now effectively inhibited from processing PSD packages and operator intervention, using the disaster recovery process, is needed to return it to operation.

In summary, the checkpoint validation and auto-recovery processes allows the module to verify that the database providing records is up to date and to automatically resynchronize the module with the database if possible.

An Audit Log Verification protects PSD Package Replay. Use of a DES MEC to authenticate a PSD package ensures that the record originated from a module with knowledge of the client's package DES MAC key. The DES MAC verifies that the data within the record has not been modified since the DES MAC was generated. But because the DES MAC cannot ensure that the record is the most recent update of the client's data, other safeguards need to be used to prevent or detect substitution of a record created at an earlier time. The module addresses this problem by creating a cryptographically protected audit log entry each time a PSD package is modified by a module. The command scaaeCreateAuditEntry is used to create the audit record.

25 An Audit Log Verification protects PSD Package Replay. Use of a DES MEC to authenticate a PSD package ensures that the record originated from a module with knowledge of the client's package DES MAC key. The DES MAC verifies that the data within the record has not been modified since the DES MAC was generated. But because the DES MAC cannot ensure that the record is the most recent update of the client's data, other safeguards need to be used to prevent or detect substitution of a record created at an earlier time. The module addresses this problem by creating a cryptographically protected audit log entry each time a PSD package is modified by a module. The command scaaeCreateAuditEntry is used to create the audit record.

The initialize cryptocard or update cryptocard commands perform the initializations. Limits are set for the minimum and maximum value of indicium that can be printed. The USPS certificate authority public key certificate is loaded. The provider public key is loaded. Private keys used during new customer registration are loaded. These commands are issued by the Security Officer.

The initialize PSD command assigns the device ID, set the postal registers to zero and

1 generates the PSD public keys. This command is not authenticated but can only be executed once in the life of a PSD.

The authorize PSD command loads the PSD's public key certificate. The PSD's certificate is authenticated by the CA certificate, and the device ID and public key from the certificate are
5 verified to match those contained in the PSD package.

The configure PSD command enters the new customer's customer ID and receives the encrypted secrets from the customer. The module decrypts the secrets using VRSK_ipost. Preferably, this command is not authenticated but the response returned to the customer is DES
10 MAC'ed by the module with the CDSK_client key just received. The customer PC software verifies this DES MAC to ensure that the module has received the CDSK_client key correctly.

The authorize customer command enters the originating zip code after the server receives the meter license and then the maximum descending register limit is set. This command is authenticated as a provider role command from the provider's signature using the key
15 UDSK_auth.

As described above, the cryptographic modules use roles and services to control access to the module and to specify which services (commands) are available to the user. Services of concern are those that access security parameters or postal financial data protected by the module. Each module supports many roles. In one embodiment, access control is accomplished as
20 follows.

Authentication may be accomplished by using a secure session. For example, the roles of Security Officer, Key Custodian, Administrator, and Auditor are authenticated after a secure session between the user's PC and the module has been established. When the user issues an scasmOpenSession command, application software on the user's PC and corresponding software
25 in the module perform the session opening process. An anonymous Diffie-Hellman key generation protocol is used to establish a set of session keys (triple DES keys for encryption and MAC'ing) that are used during the session. The session keys are not used directly but instead unique keys, derived from the session keys, are used for each successive message.

Once a secure session is established, the user sends the scaacLogon command containing
30 the user ID and user password. The module uses its access account database to verify the user data received and to select the role that this user is allowed to enter. The user can now send the module any command allowable for the selected role. In one embodiment, the module design limits each user to a single role and will only allow one user to be logged on at a time.

Session management provides security services to the communications between the host
35 and the module. Session management will establish a secure channel between the host application and the module application. This channel provides authentication and optional confidentiality for the data exchanged through it. In particular, all command requests and responses, except those for opening a session, are protected by a MAC. This provides

1 authentication to the command. The host and module can verify that it is their counterpart that issued the command because no other entity can generate the MAC. Optionally, the command data can also be encrypted. This provides confidentiality to the channel.

5 All commands from the host are initiated by a user that is authorized to execute this command on the module. That is, all host-initiated commands require an active user with an appropriate role (authorized to issue the given command). Except for Default role, this implies that a user (with that role) should be currently logged on. For all users with roles other than Default, the session management is closely tied to user logon. A session should be established before the logon and it lasts while the user is logged on. The session can be terminated after the user logs off. Logon fails if no session is established; session termination fails if a user is still
10 logged on. Similarly, any module command that requires session security (encryption or a MAC) is aborted if this mechanism is not used. An active session is instantiated by active session master keys. These keys are exchanged between host and module application at session set-up, and they are destroyed at session termination. All data transmitted between the host and the
15 module within a certain session is protected by these session master keys. All data is authenticated (by means of a MAC); in addition, some data is encrypted to preserve confidentiality.

Preferably, session master keys are not used directly. Instead, a temporary key is derived from a session master key for each transmission. This transaction key is then used to MAC or
20 encrypt the transmitted data. The transaction keys are derived as a one-way function of the session master keys and a nonce (e.g., a transaction sequence counter). This set-up with session master keys and derived transaction keys is straightforward, and it protects the session master key. The transaction keys are protected by limiting the amount of ciphertext available for attacks. In addition, even if they would be revealed, the use of a good one-way function together
25 with nonce for the derivation of the transaction keys are sufficient to secure the session master key.

The Session Master Keys are obtained from an anonymous, unauthenticated key exchange. In one embodiment, the key exchange protocol is an anonymous (ephemeral-ephemeral) Diffie-Hellman protocol executed between the host application and the module application. The system
30 parameters (a strong prime p , and a generator g) are fixed. That is, they are hard-coded into the software at both ends. This protocol establishes a shared secret that can be used to create a secure channel between the two end entities.

Anonymous Diffie-Hellman does not provide authentication of the end entities or key confirmation. However, the module can implicitly authenticate the host via user logon and
35 application data authentication provided from outside of the module. Similarly, the host implicitly authenticates the module by verifying that it can process the application data. Finally, key confirmation is achieved at the first exchanged message.

Session Management functions include:

- 1 • Session Management Services
 - Open Session
 - Close Session
- Session Security:
 - 5 • Compute Session MAC
 - Verify Session MAC
 - Session Encrypt
 - Session Decrypt

10 Role Access may be accomplished by Command Authentication. Because many customers need to be provided rapid access to the module, commands from each customer are individually authenticated to provide access control. Each customer has a DES MAC key (CDSK_client) and generates a DES MAC for each command sent to the module. The module uses its copy of CDSK_client from the customer's PSD package to perform the command authentication. This meets the requirements for identity-based role authentication. Individual
15 command authentication ensures that each customer is authorized to enter the customer role and that the command is an authorized service of the customer role.

The provider role also uses command authentication. Provider commands are signed with the key VDSK_auth. The e-commerce server provides the interface to the USPS infrastructure and also functions as the provider when interacting with PSD Packages. When a customer's
20 postal license is approved, the provider sends an authorize_customer command to the module to store the licensing zip code and maximum descending register value in the customer's PSD Package. Completion of the authorize_customer command places the PSD Package in the *leased* state, allowing it to begin operating.

When the e-commerce server is notified that the customer has deposited funds to buy
25 postage, a download postage value command, signed by the provider key, VDSK_auth, is sent to the module. The Certificate Authority role is used to load the PSD's public key certificate. This command (authorize PSD) is authenticated when the signature on the certificate provided with the command is authenticated by the CA certificate contained in the module. Some
30 commands from the server to the module do not require authentication. These commands are used to prepare a PSD for operation, to request status from a PSD, or to facilitate system operation, for example. None affect data within operating PSD packages.

When the server receives a message from the client requesting an indicium, it forwards
the request to the module using the create indicium command. Whenever a client's PSD package is required to perform a module service, the server provides it to the module with the command.
35 The PSD package and the client-provided data elements for the indicium are then used by the module in the following way.

1. The indicia signing key token is decrypted and the DES MAC key is derived from it. This key is used to verify the DES MAC for the package.

- 1 2. The PSD state is checked. Preferably, the package should be in the leased state for this command to be executed.
3. The meter number in the command should match the meter number in the PSD package.
- 5 4. The challenge included in the client message is verified.
5. The key token containing the client secrets is decrypted and the DES MAC on the client's request is verified to authenticate the client with his PSD package. This also authenticates the command into the user role.

10 After the above checks are completed, the module is assured of the identity of the client making the request, and is certain that it has a valid PSD package for that client. The module can now perform the requested register modification process.

6. The value of the indicium is then checked to ensure it is within the minimum and maximum limits enforced by the module.
7. The DR is checked to see if it contains sufficient value for the indicium.
- 15 If the above tests are successfully completed, the module completes the indicium creation process:

8. The indicium value is subtracted from the DR and added to the AR.
9. The data elements for the indicium are assembled and the indicium signature is generated.
- 20 10. The message that will be sent to the client is assembled. In addition to the indicium, this includes the challenge received from the client in the indicium creation request and a new challenge generated by the module that will be returned in the next message from the client. A DES MAC for this message is generated using the client's CDSK_client key.
- 25 11. The PSD package and checkpoint record are updated and DES MAC's are generated for both.
12. The audit log record is then generated.

30 To broaden the appeal of the IBIP architecture to the small business and enterprise market, one embodiment of the present invention allows multiple employees within a company to access a meter registered to that company as shown in FIG. 8. This embodiment supports such an architecture by leveraging the existing security characteristics of the Postage Server Cryptomodule. In particular, the invention employs identity-based authentication, which is needed to meet the FIPS 140-1 security level 4 requirements. As depicted in FIG. 8, multiple users within an enterprise account are connected via the Internet and a firewall to the Postal server, Postal Transaction server, Provider server, and e-commerce server.

35 In a single user model where there is a direct one-to-one mapping from customer to PSD, only a single secret needs to be shared between the individual and the cryptographic module. This secret allows the PSD to authenticate the communication with the user. To provide this

1 capability for multiple users, the PSD needs to have access to their secrets as well. In this
embodiment of the present invention, the PSD supports the ability to share secrets with multiple
users, so that it may perform identity-based authentication of these users. To support this
capability, existing services are modified for them to support multiple secrets. Preferably no
5 change is necessary to the secure protocol the system uses to communicate with the user.

Additional user management capabilities support multiple users in a PSD. This is
provided through the addition of new services needed to support the administration of a PSD's
authorized users. Also, a new role called "customer administrator", is added that has the
authority to perform the new services. This embodiment supports multiple users per PSD,
10 supports multiple machines per PSD. In this embodiment, preferably, all users are within the
same license. Preferably there is no additional restrictions on a user's capabilities.

In one embodiment, the system of the present invention allows multiple individuals to
function as a single customer by separating the user interface function of the host system from
the other core functions. An individual interacts with the machine performing the user interface
function, which in turn, then communicates with the machine performing the other core
15 functions. The machine performing all core functions of the host system, excluding the user
interface, is called a gateway machine. This machine acts, on behalf of the individuals, to
perform all customer functions. Multiple individuals are communicating with the gateway from
different machines, each of which is performing the user interface function of the host system.
20 These machines are called interface machines.

In this embodiment of the present invention, the gateway is performing the user
authentication function. As such, the gateway is responsible for supporting secure
communication between the customer and its PSD. This means that the gateway performs the
authentication of all messages sent to and received from the PSD.

25 As previously mentioned, the gateway also performs all other core functions of the host
system (excluding the user interface function). Performing these functions at the gateway
provides many benefits due to its centralized nature, including consolidated usage logging and
simpler configuration management.

A customer entity is responsible for the security of the host system used to access the
30 system. In this embodiment, a gateway and one or more interface machines embody the host
system. To provide the same level of security as that afforded by a single machine model, it is
necessary for the communication between the interface machines and the gateway to be private
and tamper-resistant with respect to the community of users accessing the host system.

35 When and if the interface machines and the gateway all reside on a network private to the
user community sharing the PSD, typically, no additional security is necessary to protect their
communication. For example, a corporate LAN is typically protected with a firewall that
prevents the machines within the private network from being accessed externally.

In this embodiment, the mechanism by which a customer submits a request to purchase

1 postage to the provider infrastructure is performed on the gateway machine. Additionally, the
corresponding purchase approval and download of postage value to the PSD is performed by the
provider infrastructure and is preferably unaffected by the introduction of the gateway
component. FIG. 9 shows multiple users using a gateway server to generate secure indicium
5 bitmaps. Users can be connected to the gateway system via a private network or using a secure
channel such as SSL if they are using a public network to access the gateway system. Users can
print the indicium generated from the gateway system using network printers or local printers that
are available. Also, they can use printers connected to the gateway system.

10 In one embodiment, an IBI solution that allows users to use IBI from within a standard
web browser tool is used. However, running in the browser environment where the UI and
potentially code are delivered dynamically over the Internet brings with it additional security
requirements. Improperly designed browser-based IBI systems could allow a number of attacks
over the network that are not possible in an application-based system. These include the theft
of indicia, substitution of values in indicia (printing something different than the user requested),
15 substitution of values in postage purchases, and the theft of personal information. Generally,
printing of indicia can be broken down into the following exemplary steps: entry of values into
UI, generation of indicium by PSD, and Printing.

20 Typically, the security of an IBI system is dependent on the security of the steps above. In an
application-based product these steps are either contained within one cryptoboundary or protected by a
private, tamper resistant communication mechanism (e.g., SSL). There is a high degree of assurance that
what is requested is what is printed and that no one is able to intercept the indicium. A browser plug-in
that displays its own native code UI for collecting data for the indicium and prints the indicium itself is
shown in FIG. 10. This browser offers the same protections as an application. Untrusted code (e.g.,
JavaScript) cannot access the data in the UI and transparently modify or steal it.

25 A UI-less (also known as, "headless") browser plug-in that generates and prints indicia with the
UI provided by web pages is potentially unsafe. A plug-in installed in this manner is visible to all web
pages, not just to pages from the original site. This allows attacks on the first arrow. Input can safely
be taken from a web page, but only by providing a way to ensure only authorized pages can create and
print indicia. It is possible to ensure that the plug-in is being called by an authorized web page by having
30 the plug-in check the browser's Document Object Model to check to see if the page was delivered by
SSL (to eliminate spoofing) and whether it came from an authorized domain (e.g., *.stamps.com). If
both of these are true, then the plug-in can trust the web page as its UI because the web page has been
strongly authenticated to be from an authorized source. This can also be accomplished by having the
customer's web browser connect to a web server (proxy) running within the same cryptoboundary, as
35 shown in FIG. 10. Preferably, the proxy only allows connections to authorized domains via SSL. In
order to ensure that the proxy is only receiving requests from authorized domains, it is necessary for the
proxy to authenticate that the request came from a page it delivered to the browser. The easiest way to
accomplish this is to only accept requests over the same connection the page was delivered on, but other

1 authentication methods are possible. This browser-based design has generally greater security than application-based designs.

For authentication, each user has a unique user ID and their own password. Preferably, user administration may only be performed in the cryptographic module. Also, client transactions are authenticated to a specific user. For access control, the system is capable of granting/revoking PSD privileges (e.g., create indicia, reset password, retrieve status, retrieve UDSKpsd), and granting/revoking administrative privileges (e.g., add user, delete user, modify user, e.g. privileges, view all users). Some account features include account expiration, password expiration (enforced by client), logon failure count, and maximum total postage. Transactions associated with a specific user may be audited and administration actions are tracked in an audit trail.

Once the audit log record is generated, the server receives the audit record, the updated database records, and the indicium message to the client from the module. The server stores the audit record on the audit file server and sends the PSD package and checkpoint record to the database for storage. When the server gets confirmation that the database storage operation has been successful, the message containing the indicium is transmitted to the client application.

The create postage correction indicium command performs the correction indicia creation function. Preferably, it operates identically to the create indicium command except that it results in a correction indicium being generated.

Because redating indicia creation does not involve the PSD postal registers, the module does not perform this function. When redating of an indicia is necessary, preferably server software performs this function.

When a meter is removed from service, the create refund indicium command is used to empty the meter's DR. This command, which is a service of the provider role, is preferably sent from the provider infrastructure and signed with the provider key, VDSK_auth. Preferably, this command can only be performed if the package is in the leased state or the pwreset state. When the module receives this command the result is the creation of an indicium equal to the value remaining in the DR. Because withdrawal is a special case of a normal indicium creation operation, the module preferably performs the same series of checks as for the create indicium command, the difference being the authentication of the provider in place of the customer. As a result of this command, the AR is increased by the amount of the refund indicium and the DR is reduced to zero. The PSD package state is changed to withdrawn which inhibits this meter from any further use. The indicia data, including a signature using the client's private key, is output to the server to allow the remaining funds to be credited to the client's account. The updated PSD package, checkpoint record, and audit log record, are output to the server for storage.

VBI value download messages are sent from the provider infrastructure to the PSD. When a customer deposits funds into their account, this triggers the provider's server (the provider software) to generate a VBI value download message to the customer's PSD. This message is a service of the provider role and is signed by the provider key, VDSK_auth. The message contains the meter number,

1 control total value (from the last successful resetting), and the VBI download value. The module performs the following steps.

1. The provider signature on the message is verified.
2. The PSD package is authenticated by checking its DES MAC.
- 5 3. The PSD state is checked. Preferably, it should be in the leased state or pwreset state.
4. The meter number in the command must match the meter number in the PSD package.
5. The control total in the message must equal the sum of the AR and DR from the PSD package.
6. A check is made to ensure that the DR will not exceed a predetermined value (in one
10 embodiment, \$500) after the new VBI is loaded. A check is also made to ensure that the AR will not exceed predetermined value after the new VBI is spent.
7. If the above tests pass, the module increments the DR by the VBI amount contained in the message.
8. The PSD package and checkpoint record are updated and DES MAC's are generated for
15 both. These are output to the database server for storage.
9. The audit log record is generated and output to the server for storage on the audit file server.

Audit support provides functions that enable secure logging of all (sensitive) actions. The security requirements include the authenticity of the entries, completeness, and the inability to insert
20 (fraudulent) additional entries. For reasons of storage space availability, the storage of the entries happens outside the module. Therefore, the security features are built into the audit entries themselves. To avoid involvement of the originating module (or cloning of the related keys) audit is public key based meaning, the audit entries are digitally signed. To address performance concerns, this is implemented as follows.

25 Instead of signing each individual audit entry, the entries are securely chained, and only selected entries in the chain are digitally signed. The security of the chaining mechanism then makes sure that any previous entries in the chain are implicitly authenticate as well. This chaining can be achieved by means of a hash function: each entry also contains a hash code of the previous entry. Modification of any entry in the chain before a given one then requires finding a second value that hashes to the same
30 hash code. (This is finding a second pre-image for the used hash function.) That is, the hash code provides a link back to the previous entry in the audit chain, and implicitly to the entire pre-existent audit chain. This is depicted in FIG. 7. In FIG. 7, the arrows between the (identical) hash codes indicate the linking back through the chain.

The only remaining risk is that the last few entries before a crash may be unsigned (and thus
35 forgeable). This risk can be mitigated by forcing a signature for certain (more sensitive) actions, in addition to forcing a signature on a periodic, recurring basis (for example, each 100 entries) as well as for the first command after a reboot.

All sensitive actions generate an audit entry. Audit entry creation functionality are exposed to

1 the module applications such that audit entries for all sensitive actions can be created. This is the
responsibility of each of the functions themselves. Audit entries are available immediately at completion
of the sensitive action, to avoid losing audit information due to a crash following it. This is done by
providing the entry as a output parameter of the command itself. Storage is the responsibility of the host
5 application. (The SCA layer can provide the tools to verify authenticity and completeness; given the
absence of sufficient storage capabilities within the module, there is no way to guarantee availability of
audit entries. Therefore, this is left to the host application.)

Audit is started at the earliest possible moment, that is, in the Start Initialization command that
effects the exit from Uninitialized state. This means that all sensitive actions following that event can
10 be audited. During the Start Initialization command an Audit Signing Key (DSA) is generated. This
event, and anything sensitive that follows can be audited by creating an audit entry.

In one embodiment, an audit entry includes:

- Audit record sequence number
- Hash of the previous audit record
- 15 • Identity of software module requesting generation of the audit record
- Identity of the command requesting generation of the audit record
- The user ID (if a user is logged on to the module)
- The user role (if a user is logged on to the module)
- The current state of the module
- 20 • The persistent state of the module
- Date/time stamp
- The reason code
- Data to be stored in the audit record (dependant on the requesting command)
- Signature (if required by the requesting command)

25 After the above data elements are prepared for output, a SHA-1 hash for the record is computed
and is stored in the module so that it can be included in the next generated audit record. An audit entry
is chained to the previous entry by the hash of the previous entry, as shown in FIG. 7. The chaining is
enforced by the module by always storing the last hash in persistent memory. The register used for this
is initialized to all-zero (20 bytes) for the first entry.

30 The chain of audit records begins when the start initialization command is sent to a new module.
This first command to the module generates the DSA audit signing key pair (VDSK_audit and
UDSK_audit) and uses it to sign the first audit log record. Audit records for commands that affect the
module (initialize cryptocard, checkpoint commands, etc) are always signed. Commands that affect a
PSD package are not signed but include the hash of the previous record to create a trusted chain of audit
35 records between records that are signed. The server requests a signature on every several records, for
example, every one hundredth record. The public key for authenticating audit record signatures,
UDSK_audit, is extracted from the module using the ExportAuditKey command. This command can
only be executed by the Auditor role.

1 If an audit entry cannot be generated correctly and in its entirety, this is considered an error. Since
the audit chain should not be broken, all data that is correctly obtained is returned in the audit entry. In
addition, the command that just finished execution cannot be undone anymore. Therefore, the command
5 results are returned to the caller (and eventually, the host) only if the error is non-fatal and the output
processing can be performed (i.e. does not require Session Security commands). In general, no
additional commands should be executed anymore, so the state is set to Error.

 In case the audit chain is still unbroken, the error is not fatal, and may be recoverable through a
reboot. (I.e., Persistent state is not set to error.) If the hash chain is broken, the audit is permanently
10 damaged (reliability of any entries younger than the latest signature before the error is somewhat
questionable). In this case, the error is fatal, and both Current and Persistent state are set to Error. This
is not recoverable, except through a reinitialization of the module.

 To avoid continued operation with damaged audit creation capability, the first command after
a reboot should be audited, with a forced signature. This ensures that permanently damaged audit
creation capability allows the execution of at most one command after rebooting. Since no sensitive
15 functionality can be accessed directly at reboot (e.g., at least a session and a user logon are required), this
ensures that no sensitive commands can be executed with damaged audit entry creation capabilities. In
summary, audit entry creation only leads to command failure if a fatal error is encountered. If the error
is non-fatal, an incomplete audit entry is returned for the command. In addition, the command's results
are returned to the caller if their output processing can be performed (i.e. does not require Session
20 Security commands). Also, audit entry creation set the state to Error in case of failure to deliver a
complete entry. This error is fatal (non-recoverable except through re-initialization) in case the linking
with the existing audit chain is lost. (This occurs only if the previous hash or the sequence number are
unavailable.). This is implemented by setting both Current and Persistent state to Error. This error is
recoverable through rebooting in all other cases. This is implemented by setting only Current state to
25 Error (Persistent state is not modified). The first command after booting should always generate a signed
audit entry. This ensures that no sensitive commands are executed if the audit is permanently faulty.

 The Audit Support Commands include:

- Export audit key
- Create a new audit key
- 30 • Create audit entry. This command has a flag to indicate forcing of signature.
- In addition, the Start Initialization command performs the initialization of the Audit (as
well as general module initialization) and as such is grouped in the Audit Support
module.

 External storage (external to the module) and management of the audit database is entirely up
35 to the host; neither SCA nor SHL can play a role in that. In one embodiment, the postal servers store
redundant copies of the audit log records on a mirror disk. Storage directly to disk is considered to be
more reliable than storage on the database server which is accessed through the LAN. Storing the audit
records separately from the PSD package database also protects against all data being lost if the database

1 should suffer a catastrophic failure.

5 A proper audit verifies the completeness of the audit chain, by verifying all hashes in the chain, starting from the last verified signature, and ending at the most recently created signature. In addition, all signatures encountered should be verified. Finally, the hash of the most recently created audit entry should be logged (manually) to ensure that replacement of the entire chain will be detected. For example, in FIG. 7, if Audit Entry 4 were the last entry, one would verify Signature 1, Hashes 1 through 4 (establishing that the chain is unbroken) and Signature 4. (If Audit Entry 2 were signed as well, that signature should be verified as well.) The Auditor would then log Hash 4 as verified (e.g., written in an audit report) such that the next audit can start at Signature 4. (One may still want to verify that all earlier entries are present.)

10 Provider software, running on the e-commerce server, verifies the integrity of the audit log records at predetermined time intervals. First, the chain of records from each module is verified by checking all hash values and authenticating the necessary signatures. Next, the records from all module can be combined and sorted by meter number and time to view the history of each meter. Because each PSD's AR value is recorded in the audit record after each PSD transaction, a database replay attack, which would rollback the AR to an earlier value, can be detected. If the audit log verification process fails for any reason, the Security Officer is notified, for example, by e-mail. The verification starts at the most recent entry and work back towards the entry logged for the previous audit, or the start from the entry logged for the previous audit and work forward to the most recent entry.

15 It will be recognized by those skilled in the art that various modifications may be made to the illustrated and other embodiments of the invention described above, without departing from the broad inventive scope thereof. It will be understood therefore that the invention is not limited to the particular embodiments or arrangements disclosed, but is rather intended to cover any changes, adaptations or modifications which are within the scope and spirit of the invention as defined by the appended claims.

25

30

35

1 What IS CLAIMED IS:

1. A cryptographic device for securing data on a computer network comprising:
a processor programmed to authenticate a plurality of users on the computer network for
secure processing of a value bearing item;
5 a memory for storing security device transaction data for ensuring authenticity of a user,
wherein the security device transaction data is related to the one of the plurality of users;
a cryptographic engine for cryptographically protecting data; and
an interface for communicating with the computer network.

10 2. The cryptographic device of claim 1, wherein the processor is programmed to verify that
the identified user is authorized to assume a role and perform a corresponding operation.

3. The cryptographic device of claim 2, wherein the assumed role is a key custodian role to
take possession of shares of keys.

15

4. The cryptographic device of claim 2, wherein the assumed role is an administrator role
to manages a user access control database.

5. The cryptographic device of claim 2, wherein the assumed role is a provider role to
20 authorize increasing credit for a user account.

6. The cryptographic device of claim 2, wherein the assumed role is a user role to perform
expected IBIP postal meter operations.

25 7. The cryptographic device of claim 1 further comprising a stored secret for
cryptographically protecting data.

8. The cryptographic device of claim 1, wherein the secret is a password.

30 9. The cryptographic device of claim 1, wherein the secret is a public/private key pair.

10. The cryptographic device of claim 2, wherein the processor is programmed to include a
state machine for determining a state corresponding to availability of commands in conjunction with the
roles.

35

11. The cryptographic device of claim 1, wherein the processor is stateless.

- 1 12. The cryptographic device of claim 1, wherein the processor is programmed to prevent
unauthorized and undetected modification of data.
- 5 13. The cryptographic device of claim 1, wherein the processor is programmed for preventing
unauthorized disclosure of data.
14. The cryptographic device of claim 1, wherein the processor is programmed to ensure
proper operation of cryptographic security and VBI related meter functions.
- 10 15. The cryptographic device of claim 1, wherein the processor is programmed for providing
indications of an operational state of a VBI meter.
16. The cryptographic device of claim 2, wherein the processor is programmed for supporting
multiple concurrent users and maintaining a separation of roles and operations performed by each user.
- 15 17. The cryptographic device of claim 1, wherein the processor stores information about a
number of last transactions in an internal register and compares the information saved in the register with
the information saved in a memory before loading a new transaction data.
- 20 18. The cryptographic device of claim 17, wherein the memory includes data for creating
indicium, account maintenance, and revenue protection.
19. The cryptographic device of claim 1, wherein the value bearing item is a postage value
including a postal indicium.
- 25 20. The cryptographic device of claim 19, wherein the postal indicium comprises a digital
signature.
21. The cryptographic device of claim 19, wherein the postal indicium comprises a postage
30 amount.
22. The cryptographic device of claim 19, wherein the postal indicium comprises an
ascending register of used postage and descending register of available postage.
- 35 23. The cryptographic device of claim 1, wherein the value bearing item is a ticket.
24. The cryptographic device of claim 1, wherein the value bearing item includes a bar code.

- 1 25. The cryptographic device of claim 1, wherein the value bearing item is a coupon.
26. The cryptographic device of claim 1, wherein the value bearing item is currency.
- 5 27. The cryptographic device of claim 1, wherein the value bearing item is a voucher.
28. The cryptographic device of claim 1, wherein the value bearing item is a traveler's check.
29. The cryptographic device of claim 1, wherein each security device transaction data
10 includes an ascending register value, a descending register value, a respective cryptographic device ID,
an indicium key certificate serial number, a licensing ZIP code, a key token for an indicium signing key,
user secrets, a key for encrypting user secrets, data and time of last transaction, last challenge received
from a respective client subsystem, an operational state of the respective device, expiration dates for
keys, and a passphrase repetition list.
- 15 30. The cryptographic device of claim 1, wherein the processor is capable of sharing a secret
with a plurality of other cryptographic devices.
31. The cryptographic device of claim 1, wherein the processor and the cryptographic engine
20 generate a master key set (MKS).
32. The cryptographic device of claim 31, wherein the MKS includes a Master Encryption
Key (MEK) used to encrypt keys when stored outside the device.
- 25 33. The cryptographic device of claim 32, wherein the MKS further includes a Master
Authentication Key (MAK) used to compute a DES MAC for signing keys when stored outside of the
device.
34. The cryptographic device of claim 31, wherein the MKS is exported to other
30 cryptographic devices.
35. The cryptographic device of claim 1, further comprising a memory including a user profile
for a subset of the plurality of users.
- 35 36. The cryptographic device of claim 35, wherein the user profile includes username, user
role, password, logon failure count, logon failure limit, logon time-out limit, account expiration,
password expiration, and password period

1 37. The cryptographic device of claim 10, wherein the state machine comprises of an uninitialized state, an initialized state, an operational state, an administrative state, an exporting shares state, an importing shares state, and an error state.

5 38. The cryptographic device of claim 37, wherein the operational state comprises means for access control, means for session management, and means for key management, and means for audit support.

10 39. The cryptographic device of claim 1, wherein the cryptographic engine is programmed to perform one or more of Rivest, Shamir and Adleman (RSA) public key encryption, DES, Triple-DES, DSA signature, SHA-1, and Pseudo-random number generation algorithms.

15 40. The cryptographic device of claim 1, wherein at least one of the plurality of users is an enterprise account.

 41. A method for securing data on a computer network including a plurality of users comprising the steps of:

 authenticating and authorizing the plurality of users for secure processing of a value bearing item;

20 storing a security device transaction data in a memory for ensuring authenticity and authority of one of the plurality of users, wherein the security device transaction data is related to the one of the plurality of users; and

 including cryptographically protected data using a stored secret.

25 42. The method of claim 41 further comprising the step of printing the value bearing item.

 43. The method of claim 41 further comprising the step of storing a plurality of security device transaction data in a database wherein, each transaction data is related to one of the plurality of users.

30 44. The method of claim 43 further comprising the step of loading a security device transaction data related to the cryptographic device when the user requests to operate on a value bearing item.

35 45. The method of claim 41 further comprising the steps of authenticating the identity of each user and verifying that the identified user is authorized to assume a role and to perform a corresponding operation.

- 1 46. The method of claim 45, wherein the assumed role is an administrator role to manage a user access control.
- 5 47. The method of claim 45, wherein the assumed role is a provider role to authorize increasing credit for a user account.
48. The method of claim 45, wherein the assumed role is a user role to perform expected IBIP postal meter operations.
- 10 49. The method of claim 45, wherein the assumed role is a security officer role for initiating key management function.
50. The method of claim 45, wherein the assumed role is a key custodian role to take possession of shares of keys.
- 15 51. The method of claim 45, wherein the assumed role is an auditor role to manage audit logs.
52. The method of claim 41, further comprising the step of printing a postage value including a postal indicium.
- 20 53. The method of claim 52, wherein the postal indicium comprises a digital signature.
54. The method of claim 52, wherein the postal indicium comprises a postage amount.
- 25 55. The method of claim 52, wherein the postal indicium comprises an ascending register of used postage and descending register of available postage.
56. The method of claim 41, further comprising the step of printing a ticket.
- 30 57. The method of claim 41, further comprising the step of printing a bar code.
58. The method of claim 41, further comprising the step of printing a coupon.
59. The method of claim 41, further comprising the step of printing a currency.
- 35 60. The method of claim 41, further comprising the step of printing a traveler's check.
61. The method of claim 41, further comprising the step of printing a voucher.

1 62. The method of claim 41, further comprising the step of storing a user profile for a subset
of the plurality of users.

5 63. The method of claim 62, wherein the user profile includes username, user role, password,
logon failure count, Logon failure limit, logon time-out limit, account expiration, password expiration,
and password period

10 64. The method of claim 41, further comprising the step of performing one or more of Rivest,
Shamir and Adleman (RSA) public key encryption, DES, Triple-DES, DSA signature, SHA-1, and
Pseudo-random number generation algorithms by each of the cryptographic devices.

 65. The method of claim 41, further comprising the steps of supporting multiple concurrent
operators and maintaining a separation of roles and operations performed by each operator.

15 66. The method of claim 41, further comprising the steps of:
 storing information about a number of last transactions in a respective internal register of
each of the one or more cryptographic devices;
 storing a table including the information about a last transaction in the database; and
 comparing the information saved in the respective device with the respective information
20 saved in the database.

 67. The method of claim 66, further comprising the step of loading a new transaction data if
the respective information stored in the device compares with the respective information stored in the
database.

25 68. The method of claim 41, wherein the secret is a password.

 69. The method of claim 41, wherein the secret is a public/private key pair.

30 70. The method of claim 41, wherein at least one of the plurality of users is an enterprise
account.

35

FIG. 1

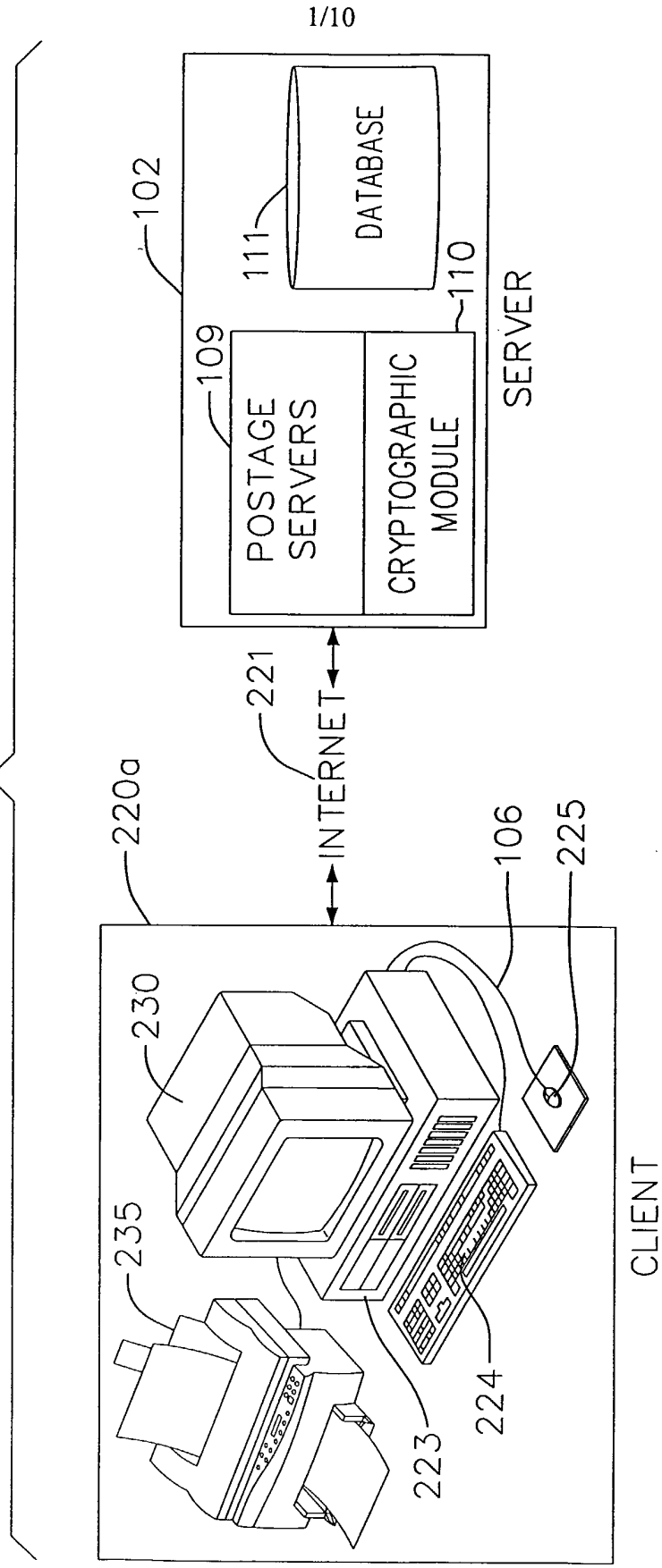

FIG. 2

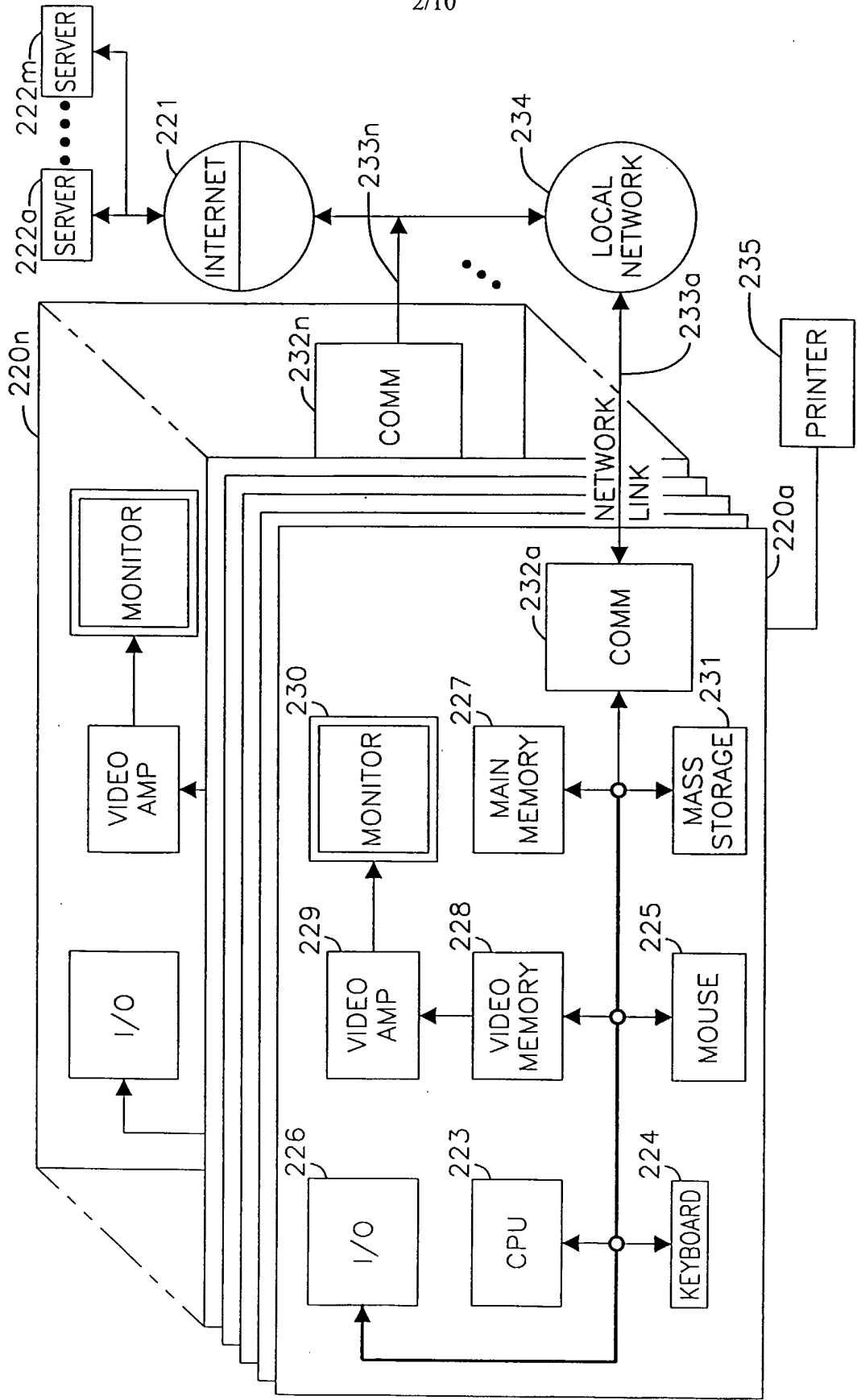
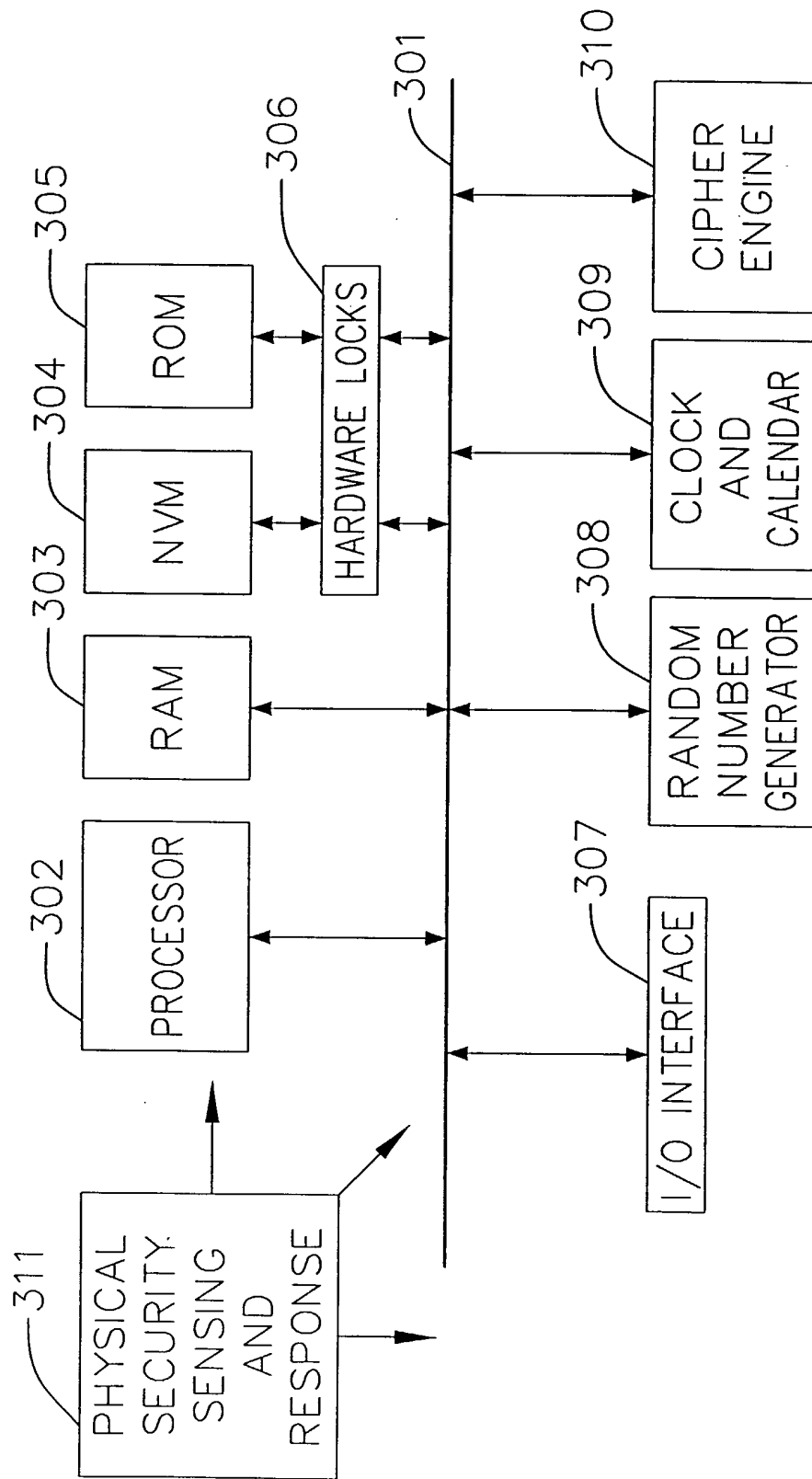

FIG. 3



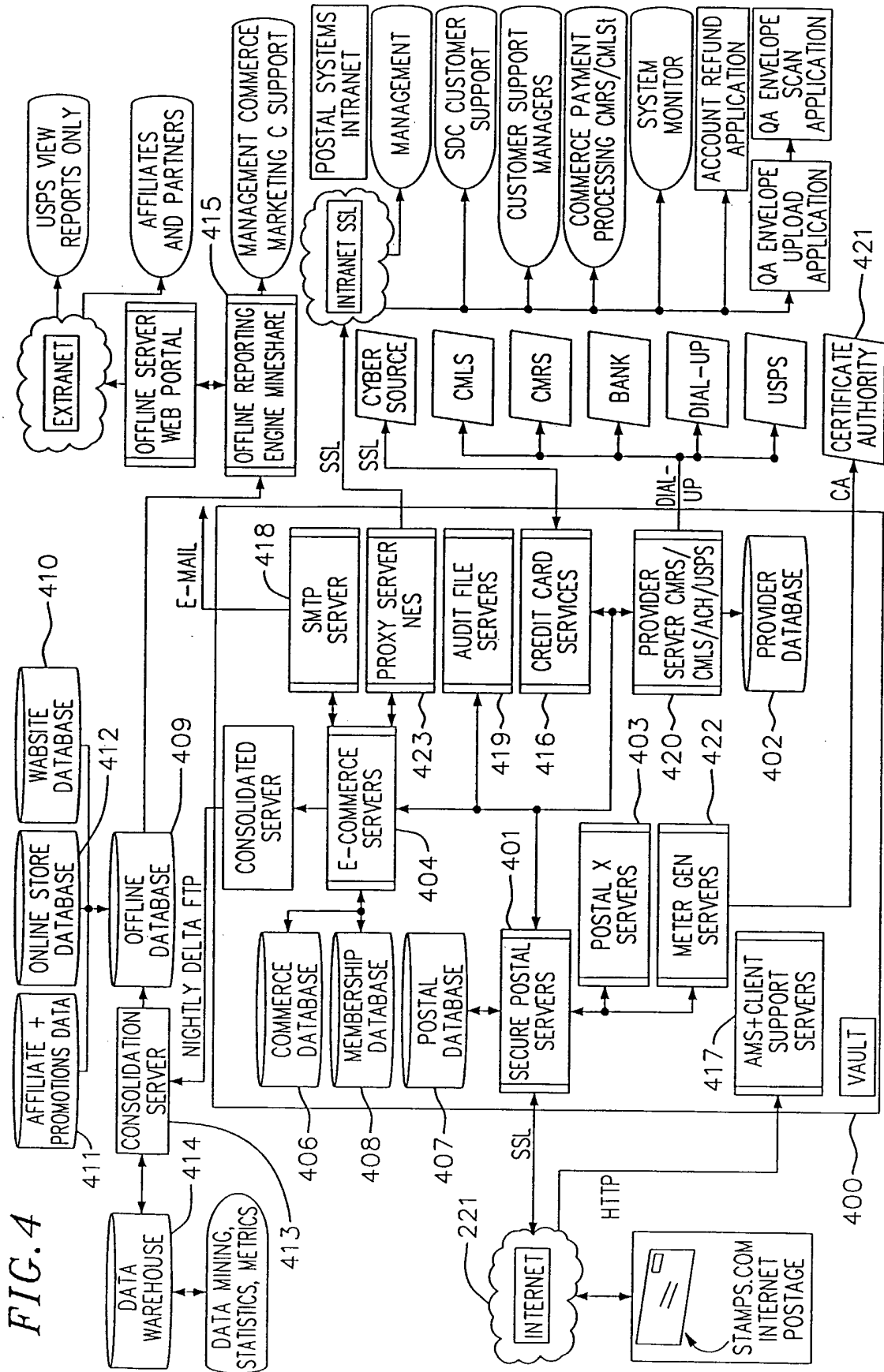
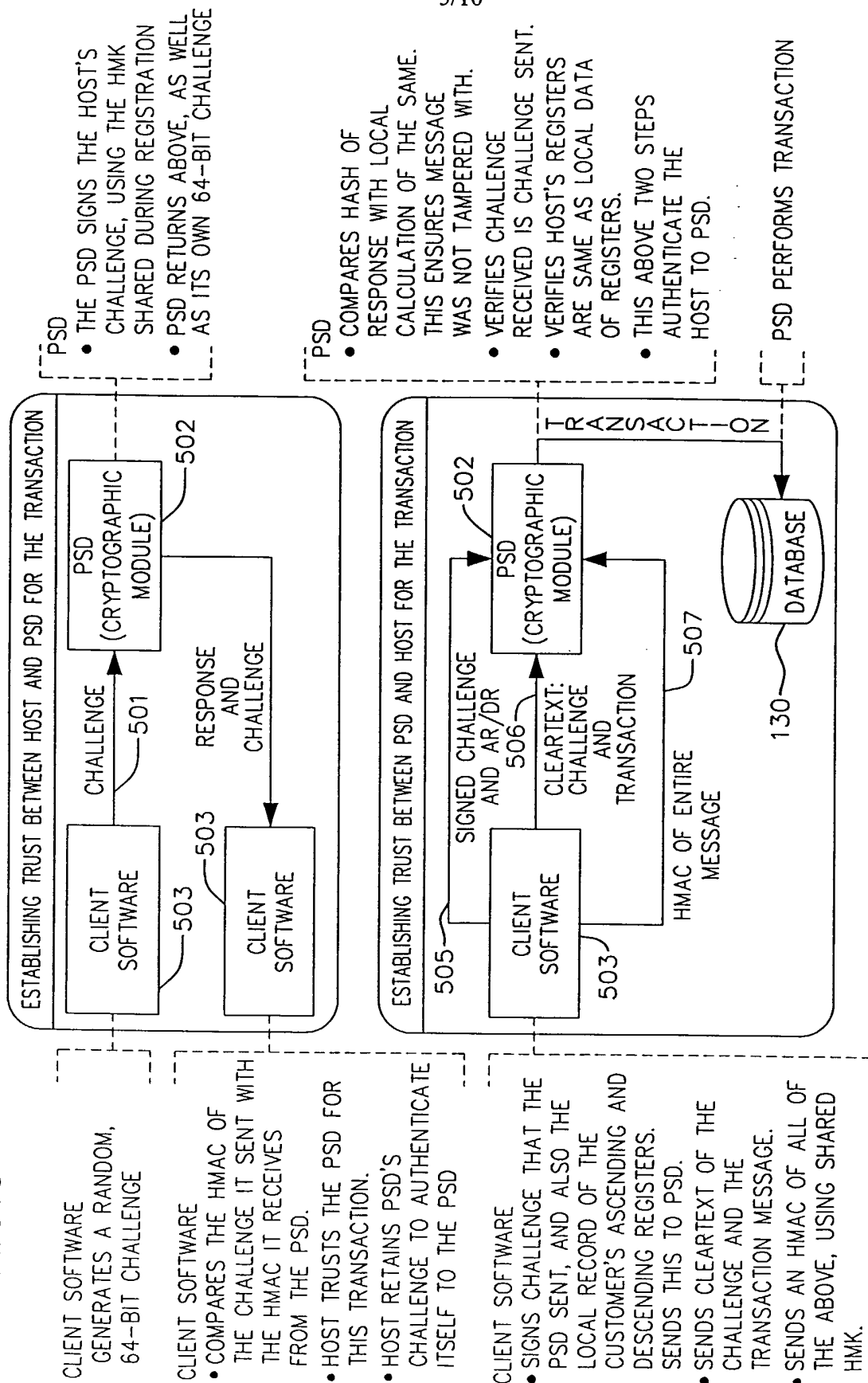

FIG. 4

FIG. 5



- PSD
- THE PSD SIGNS THE HOST'S CHALLENGE, USING THE HMK SHARED DURING REGISTRATION
 - PSD RETURNS ABOVE, AS WELL AS ITS OWN 64-BIT CHALLENGE

- PSD
- COMPARES HASH OF RESPONSE WITH LOCAL CALCULATION OF THE SAME. THIS ENSURES MESSAGE WAS NOT TAMPERED WITH.
 - VERIFIES CHALLENGE RECEIVED IS CHALLENGE SENT.
 - VERIFIES HOST'S REGISTERS ARE SAME AS LOCAL DATA OF REGISTERS.
 - THIS ABOVE TWO STEPS AUTHENTICATE THE HOST TO PSD.

PSD PERFORMS TRANSACTION

FIG. 6

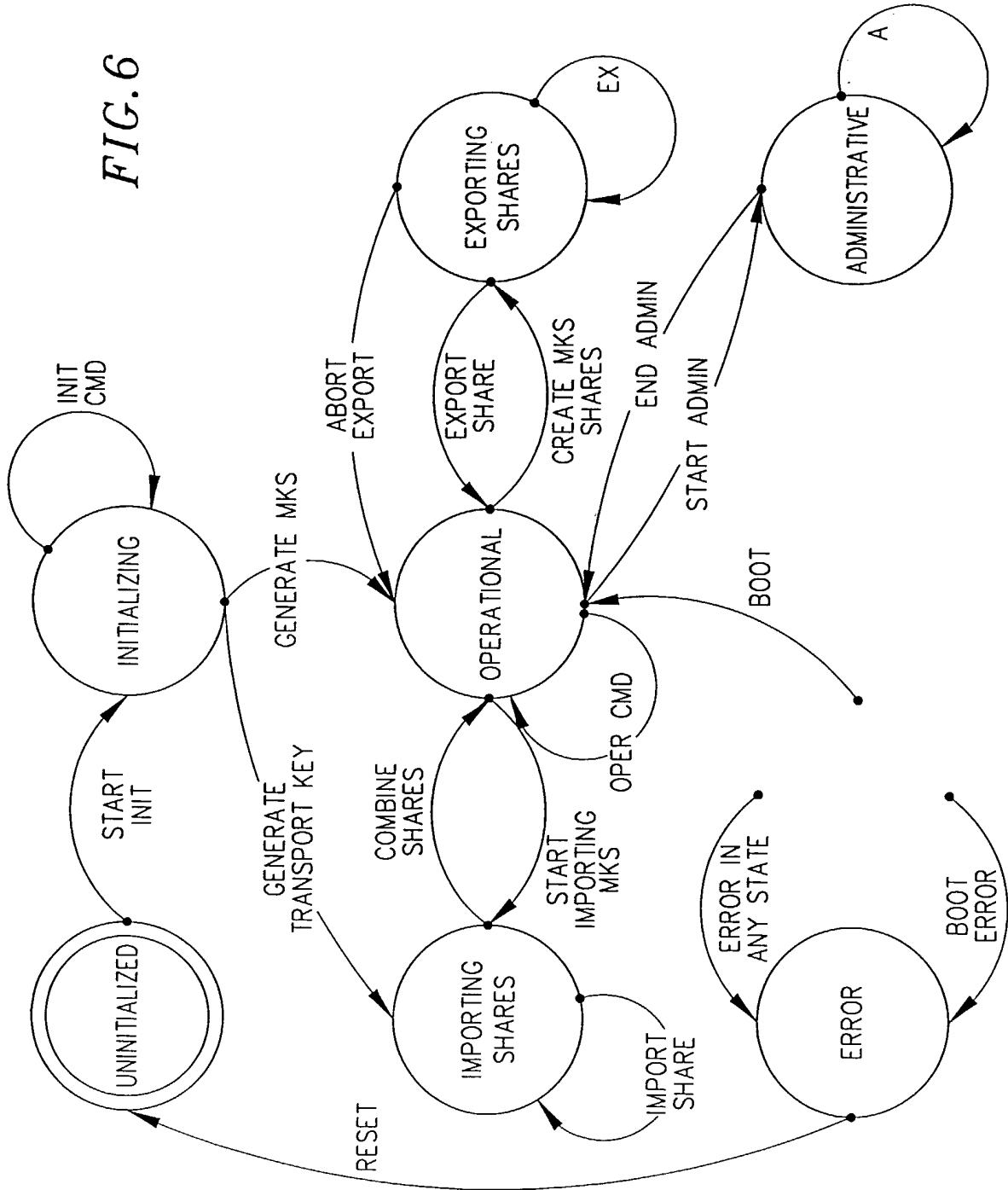

FIG. 7

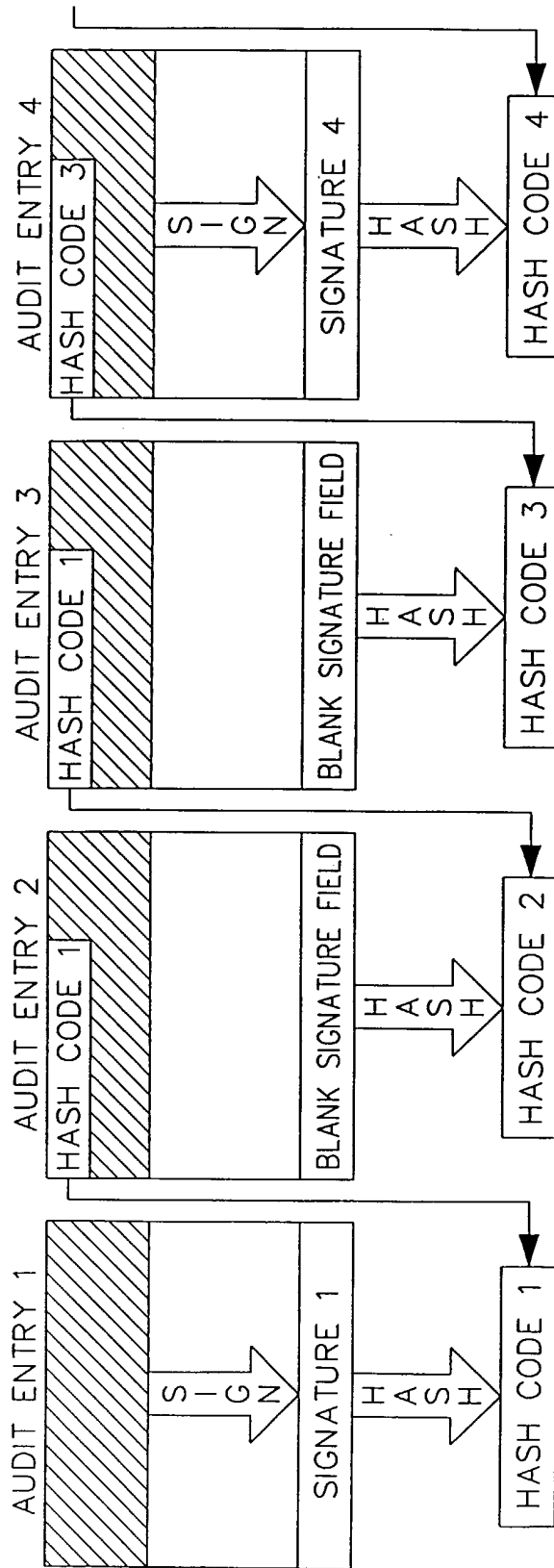

FIG. 8

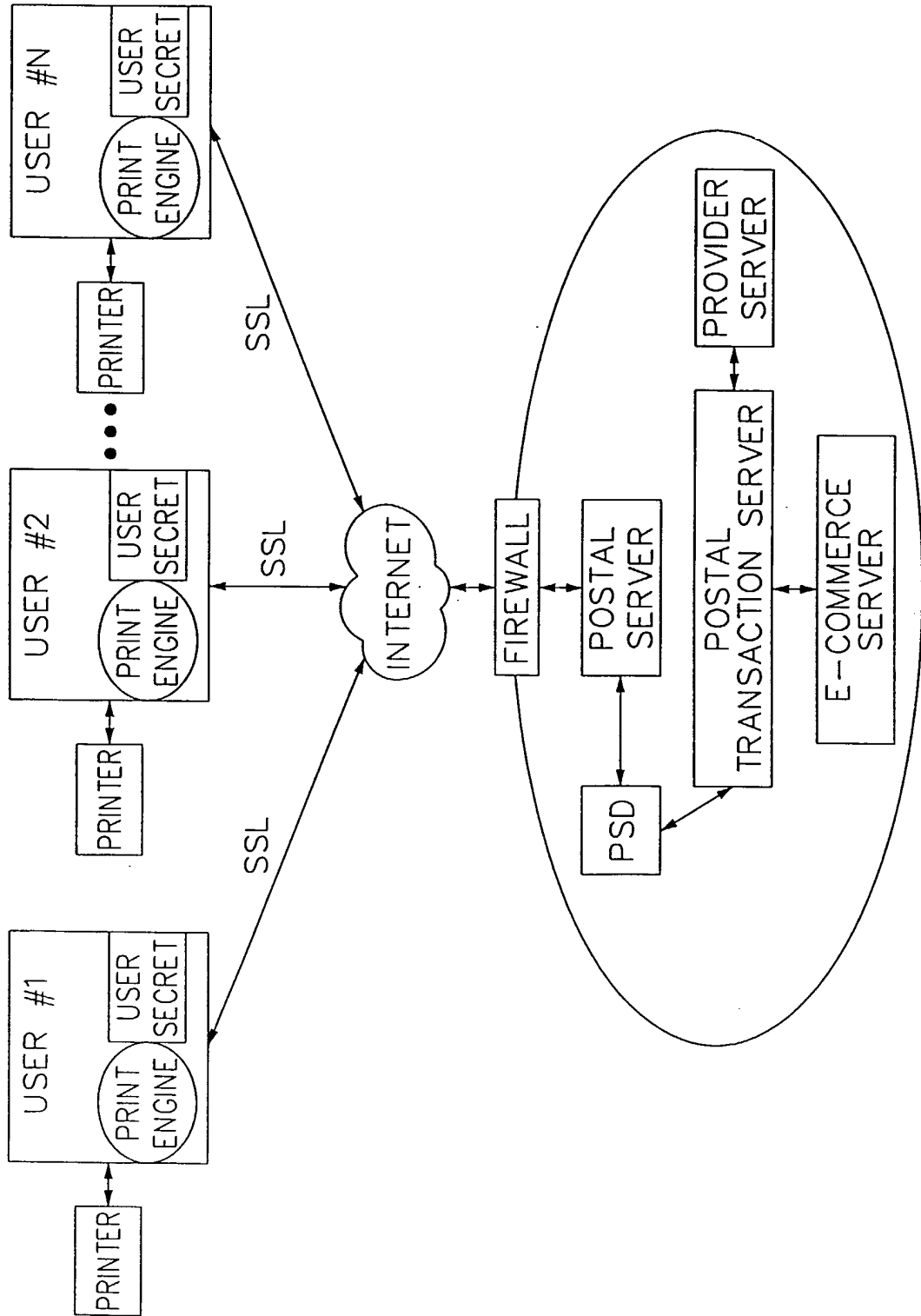

FIG. 9

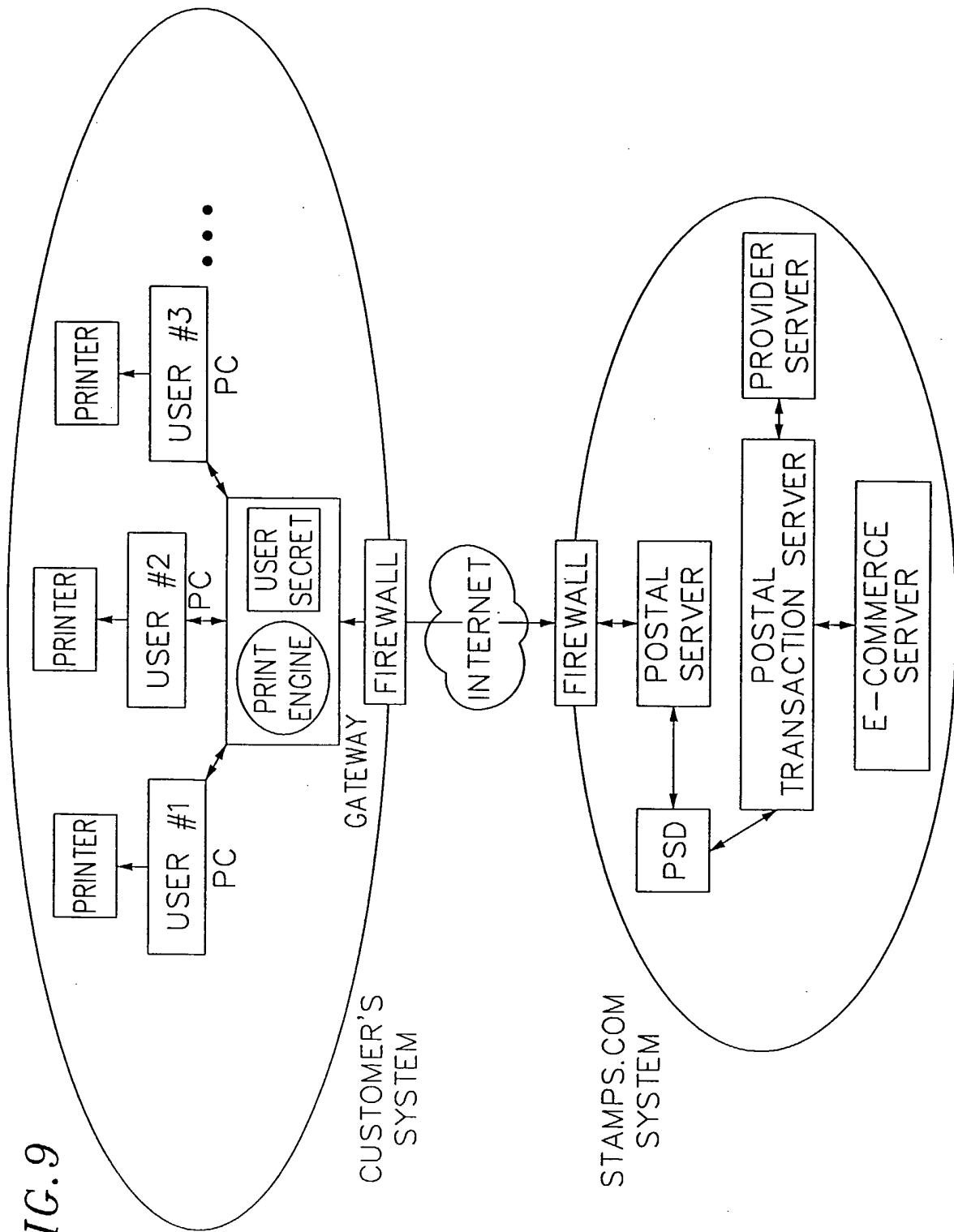
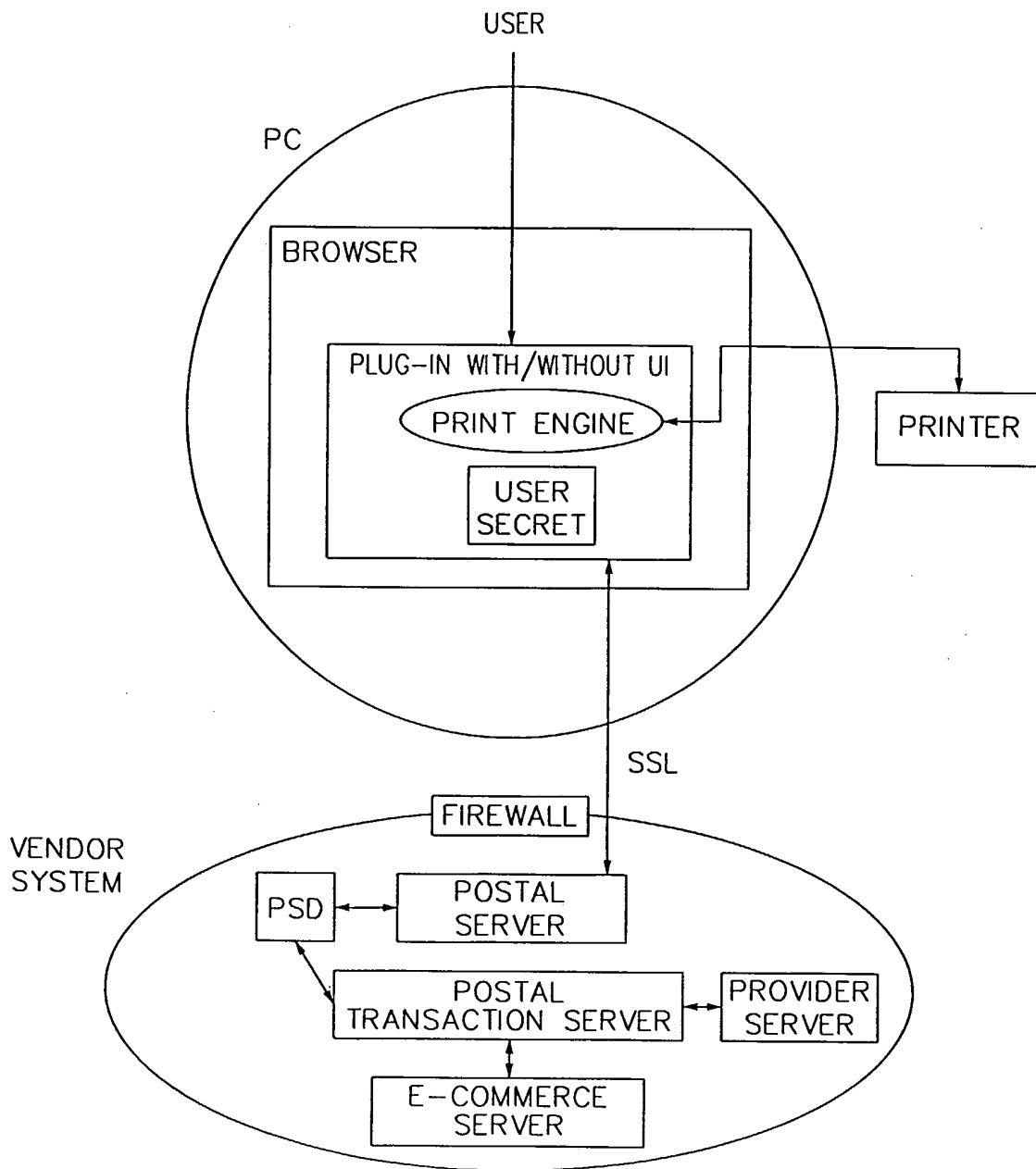

FIG. 10



INTERNATIONAL SEARCH REPORT

International Application No
PCT/US 00/28600**A. CLASSIFICATION OF SUBJECT MATTER**

IPC 7 G07B17/00

According to International Patent Classification (IPC) or to both national classification and IPC

B. FIELDS SEARCHED

Minimum documentation searched (classification system followed by classification symbols)

IPC 7 G07B

Documentation searched other than minimum documentation to the extent that such documents are included in the fields searched

Electronic data base consulted during the international search (name of data base and, where practical, search terms used)

EPO-Internal, WPI Data, PAJ

C. DOCUMENTS CONSIDERED TO BE RELEVANT

Category °	Citation of document, with indication, where appropriate, of the relevant passages	Relevant to claim No.
X	EP 0 927 958 A (PITNEY BOWES) 7 July 1999 (1999-07-07)	1,7-9, 11-15, 17-30, 39-44, 56-61, 64,66-70
Y	claim 1; figure 1	2-6,10, 16, 31-37, 45-49, 51-55,65
Y	US 4 802 218 A (BRISTOW STEPHEN ET AL) 31 January 1989 (1989-01-31) claim 1; figure 3	2-6,10, 16, 35-37, 45-49, 51-55,65
	-/--	

 Further documents are listed in the continuation of box C. Patent family members are listed in annex.

° Special categories of cited documents :

- *A* document defining the general state of the art which is not considered to be of particular relevance
- *E* earlier document but published on or after the international filing date
- *L* document which may throw doubts on priority claim(s) or which is cited to establish the publication date of another citation or other special reason (as specified)
- *O* document referring to an oral disclosure, use, exhibition or other means
- *P* document published prior to the international filing date but later than the priority date claimed

- *T* later document published after the international filing date or priority date and not in conflict with the application but cited to understand the principle or theory underlying the invention
- *X* document of particular relevance; the claimed invention cannot be considered novel or cannot be considered to involve an inventive step when the document is taken alone
- *Y* document of particular relevance; the claimed invention cannot be considered to involve an inventive step when the document is combined with one or more other such documents, such combination being obvious to a person skilled in the art.
- *Z* document member of the same patent family

Date of the actual completion of the international search

15 February 2001

Date of mailing of the international search report

23/02/2001

Name and mailing address of the ISA

European Patent Office, P.B. 5818 Patentlaan 2
NL - 2280 HV Rijswijk
Tel. (+31-70) 340-2040, Tx. 31 651 epo nl,
Fax: (+31-70) 340-3016

Authorized officer

Kirsten, K

INTERNATIONAL SEARCH REPORT

International Application No
PCT/US 00/28600

C.(Continuation) DOCUMENTS CONSIDERED TO BE RELEVANT		
Category °	Citation of document, with indication, where appropriate, of the relevant passages	Relevant to claim No.
Y	EP 0 948 158 A (FRANCOTYP POSTALIA GMBH) 6 October 1999 (1999-10-06) claim 1; figure 2 ----	31-34
A	EP 0 927 963 A (PITNEY BOWES) 7 July 1999 (1999-07-07) claim 1; figure 1 ----	1-70
A	WO 98 57302 A (RAHRIG JOHN G ;RILEY DAVID W (US); GRAVELL LINDA V (US); PINTSOV L) 17 December 1998 (1998-12-17) claim 1; figure 1 ----	1-70
A	EP 0 840 258 A (PITNEY BOWES) 6 May 1998 (1998-05-06) claim 1; figure 1 ----	1-70
A	US 4 935 961 A (GARGIULO JOSEPH L ET AL) 19 June 1990 (1990-06-19) claim 1; figure 5 ----	1-70
A	WO 94 27258 A (SPAULDING JOHN ;INTERACTIVE TELEVISION SYSTEMS (US); RHOADES DONAL) 24 November 1994 (1994-11-24) claim 1; figure 1 ----	1-70
A	USPS: "IBIP Postal Security Device Specification" USPS IBIP, 13 June 1996 (1996-06-13), XP002137734 the whole document -----	1-70

INTERNATIONAL SEARCH REPORT

Information on patent family members

International Application No

PCT/US 00/28600

Patent document cited in search report		Publication date	Patent family member(s)	Publication date
EP 0927958	A	07-07-1999	US 6151591 A	21-11-2000
			AU 9719598 A	08-07-1999
			BR 9806686 A	03-10-2000
			CN 1232234 A	20-10-1999
			JP 11288474 A	19-10-1999
US 4802218	A	31-01-1989	AT 116778 T	15-01-1995
			AT 175512 T	15-01-1999
			AT 160456 T	15-12-1997
			AT 160039 T	15-11-1997
			AU 605443 B	10-01-1991
			AU 7961287 A	24-03-1988
			BR 8707450 A	06-12-1988
			CA 1320578 A	20-07-1993
			CA 1326911 A	08-02-1994
			CA 1335839 A	06-06-1995
			CA 1296809 A	03-03-1992
			DE 3750958 D	16-02-1995
			DE 3750958 T	08-06-1995
			DE 3752138 D	11-12-1997
			DE 3752138 T	26-03-1998
			DE 3752146 D	02-01-1998
			DE 3752146 T	09-04-1998
			DE 3752247 D	18-02-1999
			DE 3752247 T	10-06-1999
			DK 228888 A	17-06-1988
			EP 0294397 A	14-12-1988
			EP 0619563 A	12-10-1994
			EP 0619564 A	12-10-1994
			EP 0619565 A	12-10-1994
			EP 0740275 A	30-10-1996
			FI 882047 A, B,	02-05-1988
			JP 1500863 T	23-03-1989
			JP 2661932 B	08-10-1997
			NO 300660 B	30-06-1997
			WO 8801818 A	10-03-1988
			US 4864618 A	05-09-1989
			US 4900904 A	13-02-1990
			US 4900903 A	13-02-1990
EP 0948158	A	06-10-1999	DE 19816344 A	07-10-1999
EP 0927963	A	07-07-1999	US 6064993 A	16-05-2000
			AU 9717298 A	08-07-1999
			BR 9805459 A	23-11-1999
			CN 1220431 A	23-06-1999
			JP 2000105845 A	11-04-2000
WO 9857302	A	17-12-1998	AU 7961998 A	30-12-1998
			AU 7963898 A	30-12-1998
			AU 8255898 A	30-12-1998
			AU 8256698 A	30-12-1998
			AU 8567098 A	30-12-1998
			AU 8567298 A	30-12-1998
			BR 9805995 A	31-08-1999
			BR 9806225 A	21-03-2000
			CN 1234890 T	10-11-1999
			CN 1234891 T	10-11-1999

INTERNATIONAL SEARCH REPORT

Information on patent family members

International Application No
PCT/US 00/28600

Patent document cited in search report	Publication date	Patent family member(s)	Publication date
WO 9857302 A		EP 0925558 A	30-06-1999
		EP 0931299 A	28-07-1999
		EP 0925663 A	30-06-1999
		EP 0920679 A	09-06-1999
		EP 0966728 A	29-12-1999
		EP 0960394 A	01-12-1999
		WO 9857303 A	17-12-1998
		WO 9857460 A	17-12-1998
		WO 9857304 A	17-12-1998
		WO 9857305 A	17-12-1998
		WO 9857306 A	17-12-1998

EP 0840258 A	06-05-1998	US 5805701 A	08-09-1998
		CA 2219857 A	01-05-1998

US 4935961 A	19-06-1990	NONE	

WO 9427258 A	24-11-1994	AU 6912894 A	12-12-1994
