



- (51) **International Patent Classification:**  
*E06B 7/22* (2006.01)      *A01M 29/30* (2011.01)  
*E06B 7/16* (2006.01)
- (21) **International Application Number:**  
PCT/DK2018/050413
- (22) **International Filing Date:**  
20 December 2018 (20.12.2018)
- (25) **Filing Language:** English
- (26) **Publication Language:** English
- (30) **Priority Data:**
- |             |                               |    |
|-------------|-------------------------------|----|
| PA201700744 | 22 December 2017 (22.12.2017) | DK |
| PA201800009 | 08 January 2018 (08.01.2018)  | DK |
| PA201870153 | 12 March 2018 (12.03.2018)    | DK |
| PA201800160 | 13 April 2018 (13.04.2018)    | DK |
| PA201800238 | 28 May 2018 (28.05.2018)      | DK |
- PA201800923      27 November 2018 (27.11.2018)      DK
- (71) **Applicant:** RAXIT SEALS APS [DK/DK]; c/o Helle Frimand, Kongevejen 345 A, 2840 Holte (DK).
- (72) **Inventor:** FRIMAND, Claus; Kongevejen 345 A, 2840 Holte (DK).
- (74) **Agent:** NORDIC PATENT SERVICE A/S; Bredgade 30, DK-1260 Copenhagen K (DK).
- (81) **Designated States** (*unless otherwise indicated, for every kind of national protection available*): AE, AG, AL, AM, AO, AT, AU, AZ, BA, BB, BG, BH, BN, BR, BW, BY, BZ, CA, CH, CL, CN, CO, CR, CU, CZ, DE, DJ, DK, DM, DO, DZ, EC, EE, EG, ES, FI, GB, GD, GE, GH, GM, GT, HN, HR, HU, ID, IL, IN, IR, IS, JO, JP, KE, KG, KH, KN, KP, KR, KW, KZ, LA, LC, LK, LR, LS, LU, LY, MA, MD, ME, MG, MK, MN, MW, MX, MY, MZ, NA, NG, NI, NO, NZ, OM, PA, PE, PG, PH, PL, PT, QA, RO, RS, RU, RW, SA,

(54) **Title:** REINFORCED FLEXIBLE STRUCTURE OR SEAL

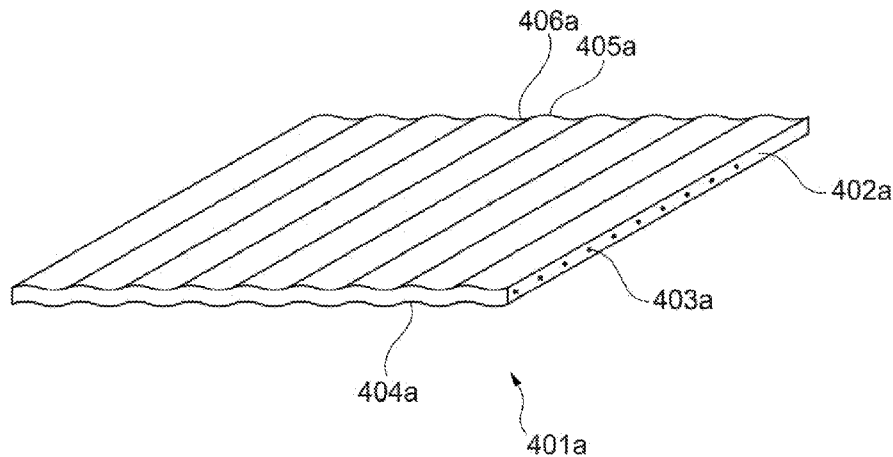

Fig. 4a

(57) **Abstract:** A reinforced flexible seal ( 101 and 201) for sealing a gap or space, such as a gap or space between an edge of a wall, fence, door, door leaf or wing, port or window and a surface adjacent to the wall, fence, door, door leaf or wing, port or window is provided. The flexible seal may be used to provide a barrier below a door leaf or door wing in order to avoid entrance of for example unwanted animals. The reinforced flexible seal has a width and a length and comprises a flexible outer material (102a, 102b, 202a, 202b), and a plurality of elongated metal wires (103, 203) embedded in the flexible outer material and running substantially in a longitudinal direction of the reinforced flexible seal with at least part of said elongated metal wires arranged at a distance to each other. For at least one of the embedded elongated metal wires, at least part of said metal wire holds several bent, bulging or wavelike deformations in the longitudinal direction of the wire.



SC, SD, SE, SG, SK, SL, SM, ST, SV, SY, TH, TJ, TM, TN,  
TR, TT, TZ, UA, UG, US, UZ, VC, VN, ZA, ZM, ZW.

- (84) Designated States** (*unless otherwise indicated, for every kind of regional protection available*): ARIPO (BW, GH, GM, KE, LR, LS, MW, MZ, NA, RW, SD, SL, ST, SZ, TZ, UG, ZM, ZW), Eurasian (AM, AZ, BY, KG, KZ, RU, TJ, TM), European (AL, AT, BE, BG, CH, CY, CZ, DE, DK, EE, ES, FI, FR, GB, GR, HR, HU, IE, IS, IT, LT, LU, LV, MC, MK, MT, NL, NO, PL, PT, RO, RS, SE, SI, SK, SM, TR), OAPI (BF, BJ, CF, CG, CI, CM, GA, GN, GQ, GW, KM, ML, MR, NE, SN, TD, TG).

**Published:**

- *with international search report (Art. 21(3))*
- *with amended claims (Art. 19(1))*

**(88) Date of publication of the international search report:**

18 July 2019 (18.07.2019)

**Date of publication of the amended claims:**

31 October 2019 (31.10.2019)

## AMENDED CLAIMS

received by the International Bureau on 24 June 2019 (24.06.2019)

CLAIMS

1. A reinforced flexible seal for sealing a gap or space, such as a gap or space between an edge of a wall, fence, door, door leaf or wing, port or window and a surface adjacent to the wall, fence, door, door leaf or wing, port or window, said reinforced flexible seal having a width and a length and comprising:
- 5 a flexible outer material; and
- a plurality of elongated metal wires embedded in the flexible outer material and running substantially in a longitudinal direction of the reinforced flexible seal with at least part of said elongated metal wires arranged at a distance to each other;
- 10 wherein for at least one of the embedded elongated metal wires, at least part of said metal wire holds several bulging or wavelike deformations in the longitudinal direction of the wire.
- 15 2. A reinforced flexible seal according to claim 1, wherein each metal wire holding bulging or wavelike deformations has a diameter or thickness, and the bulging or wavelike deformations have a top part and a bottom or lower part with a height difference between the highest point of the top part and the lowest point of the bottom or lower part;
- said difference in height between the top part and a consecutive bottom part of a bulging or wavelike deformation being at least  $\frac{1}{2}$  of said diameter or thickness, such as at least  $\frac{3}{4}$  of said diameter or thickness, such as at least the measure of said diameter or thickness, or such as at least  $1\frac{1}{2}$  of said diameter or thickness.
- 20 3. A reinforced flexible seal according to claim 2, wherein said difference in height between a top part and a consecutive bottom part of a bulging or wavelike deformation is no larger than 5 times said diameter or thickness, such as no larger than 4 times said diameter or thickness, such as no larger than 3 times said diameter or thickness.
- 25 4. A reinforced flexible seal according to any one of the claims 1 to 3, wherein each metal wire holding bulging or wavelike deformations has a diameter or thickness, and wherein the distance between two closest arranged consecutive tops of said bulging or wavelike deformations is no larger than 20 times said diameter or thickness, such as no larger than 17 times said diameter or thickness, such as no larger than 15 times said
- 30

diameter or thickness, such as no larger than 12 times said diameter or thickness, or such as about 8 times said diameter or thickness.

5. A reinforced flexible seal according to claim 4, wherein the distance between two closest arranged consecutive tops of said bulging or wavelike deformations is at least 5 times said diameter or thickness.

6. A reinforced flexible seal according to any one of the claims 1 to 5, wherein the flexible outer material has a thickness in the range of 2 to 5 times the diameter or thickness of a metal wire holding bulging or wavelike deformations, such as in the range of 2,5 to 4 times said diameter or thickness, or such as about 3 times said diameter or thickness.

7. A reinforced flexible seal according to any one of the claims 1 to 6, wherein for several or all of the plurality of elongated metal wires, at least part of said metal wires holds several bulging or wavelike deformations in the longitudinal direction.

8. A reinforced flexible seal according to any one of the claims 1 to 7, wherein said several bulging or wavelike deformations are arranged consecutively in the longitudinal direction.

9. A reinforced flexible seal according to any one of the claims 1 to 8, wherein said bulging or wavelike deformations extend substantially perpendicular to a plane defined by the lengthwise and widthwise directions of the reinforced flexible seal.

10. A reinforced flexible seal according to claim 9, wherein the flexible outer material, in which the at least one metal wire holding bulging or wavelike deformations is embedded, is deformed in accordance with the deformation of said metal wire(s).

11. A reinforced flexible seal according to any one of the claims 1 to 10, wherein at least part of or all of said plurality of elongated metal wires embedded in the flexible outer material are running substantially in parallel to each other within the flexible outer material.

12. A reinforced flexible seal according to claim 11, wherein several of said parallel running metal wires holds said several bulging or wavelike deformations in the longitudinal direction.
- 5 13. A reinforced flexible seal according to claim 12, wherein for at least two parallel running metal wires, the bulging or wavelike deformations of one wire are positioned parallel to the bulging or wavelike deformations of a neighbouring parallel wire.
14. A reinforced flexible seal according to any one of the claims 1 to 13, wherein for at  
10 least part of or all of said plurality of elongated metal wires embedded in the flexible outer material, the distance between two neighbouring wires does not exceed a predetermined maximum distance.
15. A reinforced flexible seal according to claim 14, wherein the reinforced flexible seal  
15 has a lower or outer edge, and the spacing between said lower or outer edge and a lower- or outermost positioned elongated metal wire is smaller than said predetermined maximum distance.
16. A reinforced flexible seal according to any one of the claims 1 to 15, wherein said  
20 bulging or wavelike deformations in the longitudinal direction of a wire are similarly shaped or deformed.
17. A reinforced flexible seal according to any one of the claims 1 to 16, wherein said  
25 bulging or wavelike deformations in the longitudinal direction of a wire are arranged with substantially equal spacing.
18. A reinforced flexible seal according to any one of the claims 1 to 17, wherein said  
several bulging or wavelike deformations in the longitudinal direction comprises at least 2,  
such as at least 3, such as at least 4, or such as at least 5 consecutive bulging or wavelike  
30 deformations.
19. A reinforced flexible seal according to any one of the claims 1 to 18, wherein the flexible outer material has a substantially constant thickness.

20. A reinforced flexible seal according to any one of the claims 1 to 19, wherein only elongated metal wires are embedded in the flexible outer material of the reinforced flexible seal.
- 5 21. A reinforced flexible seal according to any one of the claims 1 to 20, wherein all the elongated metal wires of the reinforced flexible seal are arranged substantially parallel to each other, and the successively arranged elongated metal wires are arranged with substantially equal spacing.
- 10 22. A reinforced flexible seal according to any one of the claims 1 to 21, wherein at least part of or all the elongated metal wires extend in the whole length of the flexible seal.
23. A reinforced flexible seal according to any one of the claims 1 to 22, wherein the flexible outer material comprises a flexible plastic material, such as flexible polyvinyl  
15 chloride, PVC, and/or wherein the flexible outer material comprises a rubber material.
24. A reinforced flexible seal according to any one of the claims 1 to 23, wherein the flexible outer material comprises a thermoplastic elastomer, TPE, type material.
- 20 25. A reinforced flexible seal according to any one of the claims 1 to 24, at least part of or all of said metal wires are arranged at a distance to each other being no larger than 8 mm, such as no larger than 7 mm, such as no larger than 6 mm, such as no larger than 5 mm, or such as no larger than 4 mm.
- 25 26. A reinforced flexible seal according to any one of the claims 1 to 25, wherein the metal wires are made of one or more of the following three materials or alloys thereof: a) iron b) steel c) stainless steel.
- 30 27. A reinforced flexible seal according to any one of the claims 1 to 26, wherein the reinforced the flexible seal has an upper part and a bottom part, and wherein  
a brush or fibre material, such as a fibre or brush strip, is attached to or integrated into the bottom part of the reinforced flexible seal and extends below said reinforced flexible seal.

28. A reinforced flexible seal according to claim 27, wherein the brush or fibre material further extends in the lengthwise direction of the flexible structure.
29. A sealed wall, fence, door, port or window assembly comprising:  
5 a wall, fence, door, door leaf or wing, port or window with a lower or outer edge, and  
a reinforced flexible seal or seal assembly according to any one of the claims 1 to 28, wherein the reinforced flexible seal is connected to the lower or outer edge of the wall, fence, door, door leaf or wing, port or window.  
10
30. A sealed wall, fence, door, port or window assembly for sealing a space between an edge of a wall, fence, door, port or window and an adjacent surface to avoid entrance of animals, insects, or water between the edge of the door or window and the surface, or to avoid temperature changes across the sealed space, said door or window assembly  
15 comprising:  
a wall, fence, door, door leaf or wing, port or window with an outer edge, and  
a reinforced flexible seal or seal assembly according to any one of the claims 1 to 28, wherein the reinforced flexible seal is connected to the outer edge of the wall, fence, door, door leaf or wing, port or window.  
20
31. A sealed wall, fence, door, port or window assembly according to claim 29 or 30, wherein an upper or connection part of the reinforced flexible seal is connected to the lower or outer edge of the wall, fence, door, door leaf or wing, port or window, and a lower or sealing part of the reinforced flexible seal extends below said lower edge or further out  
25 from said outer edge, wherein said lower or sealing part of the seal comprises several of said embedded metal wires running in the longitudinal direction of the seal and holding said bulging or wavelike deformations.
32. A sealed wall, fence, door, port or window assembly according to claim 31, wherein  
30 the elongated metal wires of the lower or sealing part of the flexible seal extend substantially parallel to the longitudinal direction of said lower or outer edge.

33. A sealed wall, fence, door, port or window assembly according to claim 31 or 32, wherein the elongated metal wires running in the lower or sealing part of the flexible seal are arranged with increasing distance to said lower or outer edge.
- 5 34. A sealed wall, fence, door, port or window assembly according to any one of the claims 31 to 33, wherein the upper or connection part of the reinforced flexible seal has no embedded metal wires, or only a part of the upper or connection part of the reinforced flexible seal has embedded metal wires.
- 10 35. A sealed wall, fence, door, port or window assembly according to any one of the claims 29 to 34, wherein the reinforced flexible seal comprises a mounting or connection part and a sealing part,  
wherein the sealing part comprises several of said metal wires embedded in the flexible outer material and running in the longitudinal direction of the seal and holding  
15 bulging or wavelike deformations, and  
wherein at least part of the mounting or connection part is connected to the wall, fence, door, door leaf or wing, port or window edge and at least part of the sealing part is positioned free from the wall, fence, door, door leaf or wing, port or window edge.

20

25