

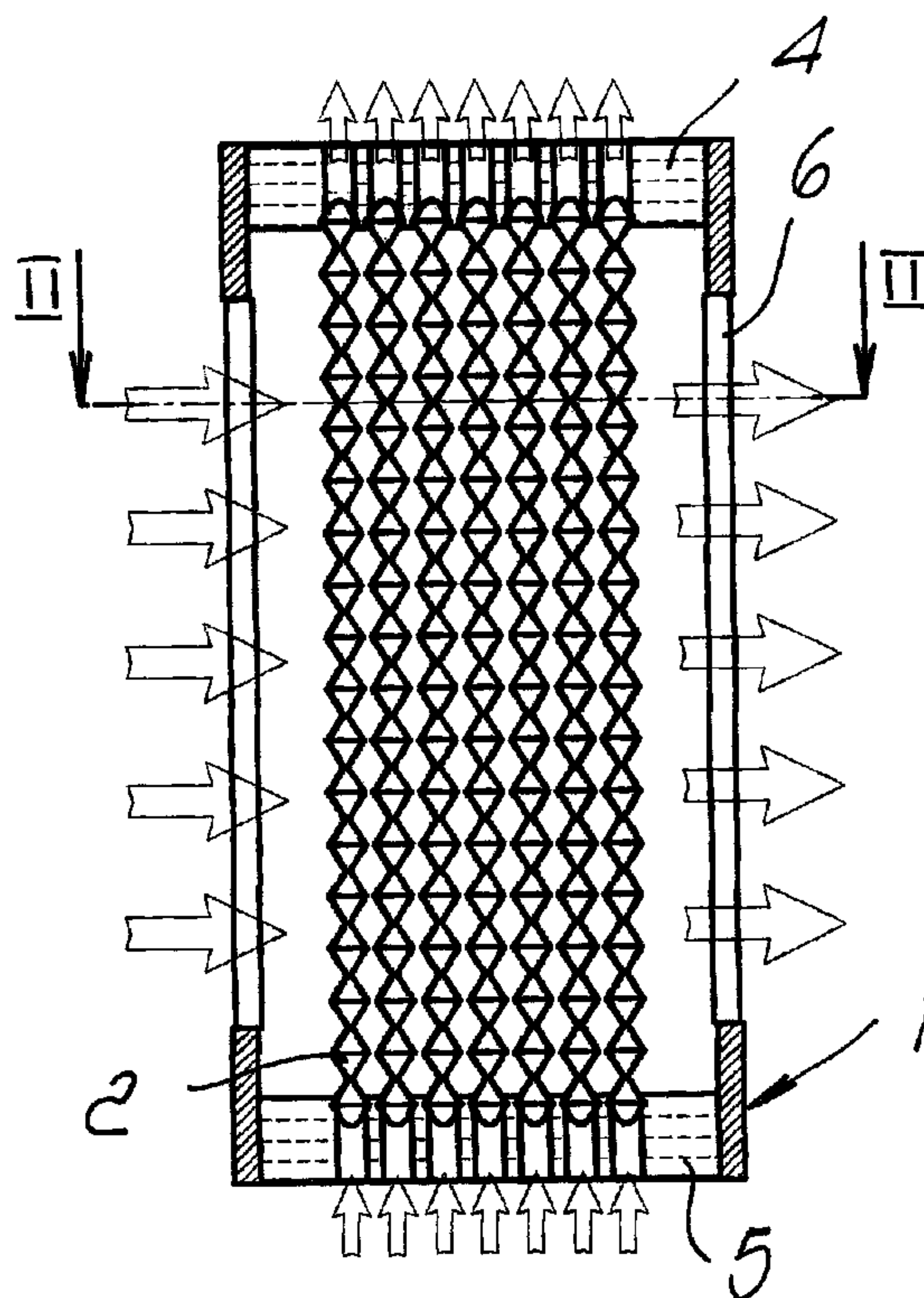

(22) Date de dépôt/Filing Date: 2006/09/27
(41) Mise à la disp. pub./Open to Public Insp.: 2007/04/10
(30) Priorité/Priority: 2005/10/10 (ITMI2005A001899)

(51) Cl.Int./Int.Cl. *F28D 1/053* (2006.01),
A61M 1/36 (2006.01), *F28F 1/06* (2006.01),
F28F 9/013 (2006.01)
(71) Demandeur/Applicant:
EUROSETS S.R.L., IT
(72) Inventeurs/Inventors:
GHELLI, NICOLA, IT;
COSTA MAIANI, EDGARDO, IT;
BALANZONI, ROBERTO, IT
(74) Agent: BCF LLP

(54) Titre : ECHANGEUR DE CHALEUR POUR USAGE MEDICAL
(54) Title: HEAT EXCHANGER FOR MEDICAL USE



(57) Abrégé/Abstract:

A heat exchanger for medical use, comprising a tube bundle formed by a plurality of tubes having a straight axis for the conveyance of a primary fluid, which are embedded at their ends in disks located at the end faces of an outer jacket which is adapted to delimit, together with the disks, a portion of space for the containment of the tube bundle which is designed to be crossed by a secondary fluid, each tube having, at least at a portion of its length, a plurality of consecutive crimps adapted to determine a progressive variation of the shape of the passage section.

HEAT EXCHANGER FOR MEDICAL USE

5

ABSTRACT OF THE DISCLOSURE

A heat exchanger for medical use, comprising a tube bundle formed by a plurality of tubes having a straight axis for the conveyance of a primary fluid, which are embedded at their ends in disks located at the end faces of an outer jacket which is adapted to delimit, together with the disks, a portion
10 of space for the containment of the tube bundle which is designed to be crossed by a secondary fluid, each tube having, at least at a portion of its length, a plurality of consecutive crimps adapted to determine a progressive variation of the shape of the passage section.

(Figure 1)

The present invention relates to a heat exchanger for medical use.

It is known that extracorporeal circuits designed to be crossed by
5 blood during certain surgical procedures comprise, among others, a device
in which the blood exchanges heat with a fluid, usually water, in order to
provide optimum temperature adjustment.

In the medical field there are also many other applications in which a
device is provided which is designed to exchange heat between a generic
10 primary fluid and a generic secondary fluid, which are thus not necessarily
constituted by blood and water.

Such heat exchanger has different shapes in the background art, and a
very common one provides for the presence of a bundle of tubes which
comprises a plurality of cylindrical tubes for conveying the primary fluid
15 which are arranged with parallel axes and are embedded at their ends in
disks located at the end faces of an external jacket which is adapted to
delimit with such disks a portion of space for containing the tube bundle;
such portion of space is intended to be crossed by the secondary fluid.

20 Such devices certainly have high-level functional characteristics, but
the aim of the present invention is to provide a device whose heat exchange
efficiency is improved further.

This aim is achieved by a heat exchanger for medical use according to
the invention, comprising a tube bundle formed by a plurality of tubes
25 having a straight axis for the conveyance of a primary fluid, which are
embedded at their ends in disks located at the end faces of an outer jacket
which is adapted to delimit, together with said disks, a portion of space for
the containment of said bundle of tubes which is designed to be crossed by a
secondary fluid, characterized in that each tube has, at least at a portion of
30 its length, a plurality of consecutive crimps adapted to determine a

progressive variation of the shape of the passage section.

Further characteristics and advantages of the present invention will become better apparent from the description of a preferred but not exclusive
5 embodiment thereof, illustrated by way of non-limiting example in the accompanying drawings, wherein:

Figure 1 is a longitudinal sectional view of a heat exchanger according to the invention;

Figure 2 is a sectional view, taken along the line II-II of Figure 1;

10 Figures 3, 4, 5 are three views of a tube according to the invention obtained by turning such tube with respect to Figure 3 first through 45° and then through 90° ;

Figures 6, 7, 8 are sectional views taken respectively along the lines VI-VI, VII-VII, VIII-VIII of Figure 3;

15 Figure 9 is a view of an embodiment of the connection of the tubes;

Figures 10 and 11 are views of different configurations of the tubes which form the tube bundle.

With reference to Figures 1 and 2, the reference numeral 1 generally
20 designates a heat exchanger according to the invention, which is designed to be inserted in an extracorporeal blood circuit and comprises a tube bundle formed by tubes 2 and 3 for conveying blood, whose axes are straight and parallel; the tubes are embedded at their ends in disks 4 and 5 located at the end faces of an outer jacket 6, which delimits, together with the disks, a
25 portion of space which contains the tube bundle and is designed to be crossed by the fluid for exchanging heat with the blood, constituted by water, along the arrows shown in the figures.

All the tubes 2 and 3 are identical, and therefore a tube according to the invention, generally designated by the reference numeral 7, is described
30 with reference to Figures 3 to 8.

Such tube has a plurality of consecutive crimps organized into two series: a first series of parallel crimps 8a, 8b, 8c, which are alternated with parallel crimps 9a, 9b, 9c of a second series, and the directions of the crimps of the two series are mutually offset through 90°.

5 This leads to a progressive variation of the shape of the blood passage section, shown in Figures 6, 7, 8 by highlighting cross-sections 10, 11, 12, which induces the blood to move with a turbulent flow, as occurs also for the water as well, with a much higher heat exchange efficiency than that which occurs in known exchangers which use cylindrical tubes, which
10 therefore produce a laminar flow of blood and of the water.

It becomes thus possible to provide compact devices which are highly advantageous in terms of space occupation, of quantity of blood contained, known as priming, and of resistance offered to the flow of the blood.

The device according to the invention can be provided with wire-like
15 elements 13 for connecting one another the individual tubes of the bundle, arranged so as to come into contact with said tubes at coplanar crimps, and thus properly kept in position.

By adopting the wire-like elements 13 it becomes easy to give to the tubes of the tube bundle a prearranged organization, as occurs for tubes 14
20 of Figure 10 or tubes 15 of Figure 11.

The described invention is susceptible of numerous modifications and variations, all of which are within the scope of the appended claims: thus, for example, the directions of the crimps can be offset in any manner and moreover the axes of the tubes, instead of being parallel, may be oblique;
25 moreover, the invention, besides being provided for single use, can be provided with means for coupling to different devices which are integrated in a single structure, as is for example the case of an oxygenation apparatus or of a cardiotomy reservoir used within an extracorporeal blood circuit.

THE EMBODIMENTS OF THE INVENTION IN WHICH AN EXCLUSIVE PROPERTY OR PRIVILEGES IS CLAIMED ARE DEFINED AS FOLLOWS:

1. A heat exchanger for medical use, comprising a tube bundle
5 formed by a plurality of tubes having a straight axis for the conveyance of a primary fluid, which are embedded at their ends in disks located at the end faces of an outer jacket which is adapted to delimit, together with said disks, a portion of space for the containment of said tube bundle which is designed to be crossed by a secondary fluid, wherein each tube has, at least at a
10 portion of its length, a plurality of consecutive crimps adapted to determine a progressive variation of the shape of the passage section.

2. The heat exchanger according to claim 1, wherein each tube has a plurality of crimps with mutually offset directions.

3. The heat exchanger according to claim 1, wherein each tube has a
15 first series of parallel crimps alternated with a second series of parallel crimps, said crimps of the two series having directions that are offset.

4. The heat exchanger according to claim 1, wherein each tube has a first series of parallel crimps alternated with a second series of parallel crimps, directions of the crimps of the two series being offset substantially
20 by 90°.

5. The heat exchanger according to claim 1, wherein at least one wire-like element is provided for mutual connection of the individual tubes of the bundle, arranged so as to come into contact with said tubes at coplanar crimps.

25 6. The heat exchanger according to claim 1, wherein the tubes having a straight axis of the bundle have parallel axes.

7. The heat exchanger according to claim 1, wherein the tubes having a straight axis of the bundle have oblique axes.

8. The heat exchanger according to claim 1, comprising means for
30 coupling to different devices integrated in a single structure.

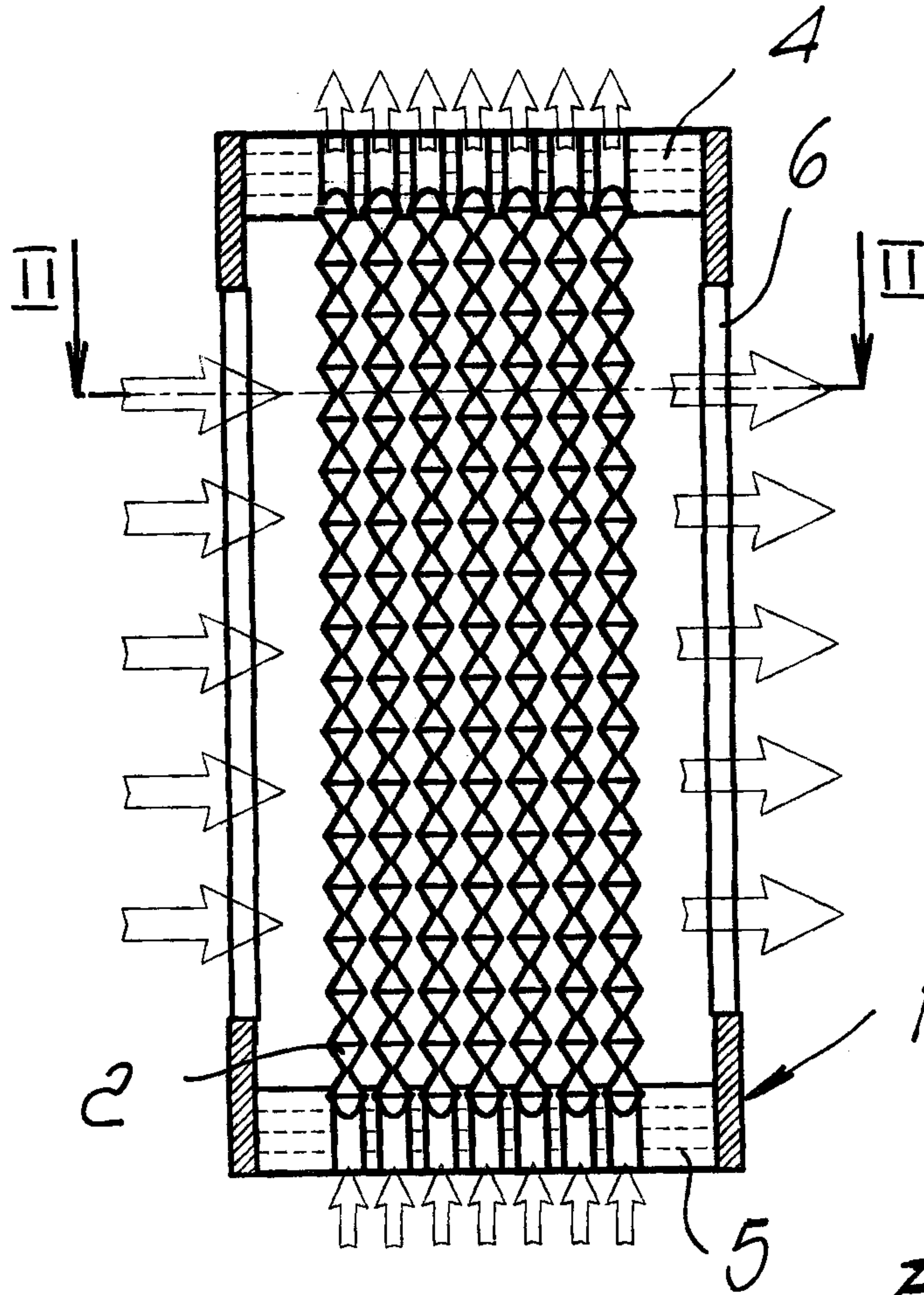

FIG. 1

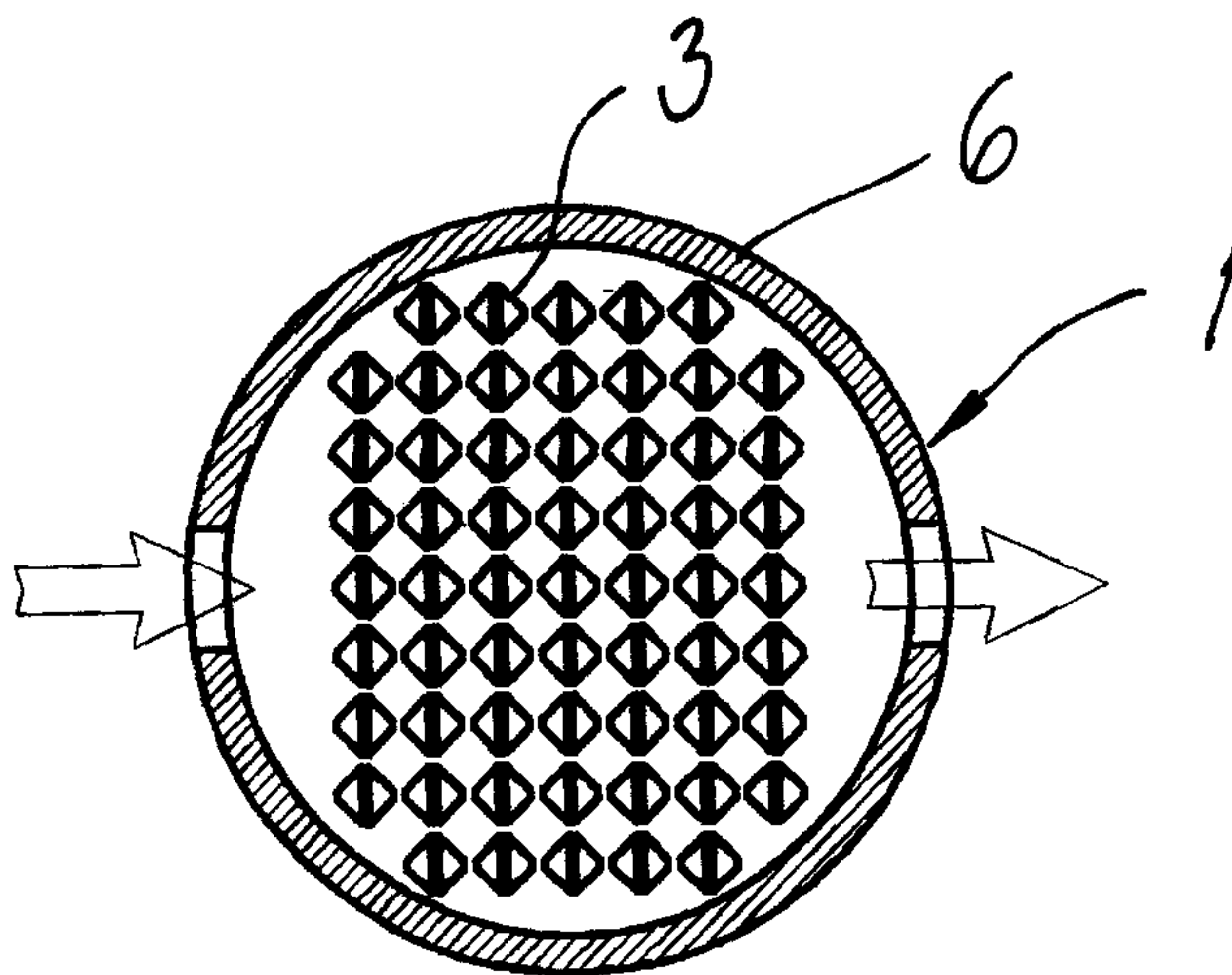

FIG. 2

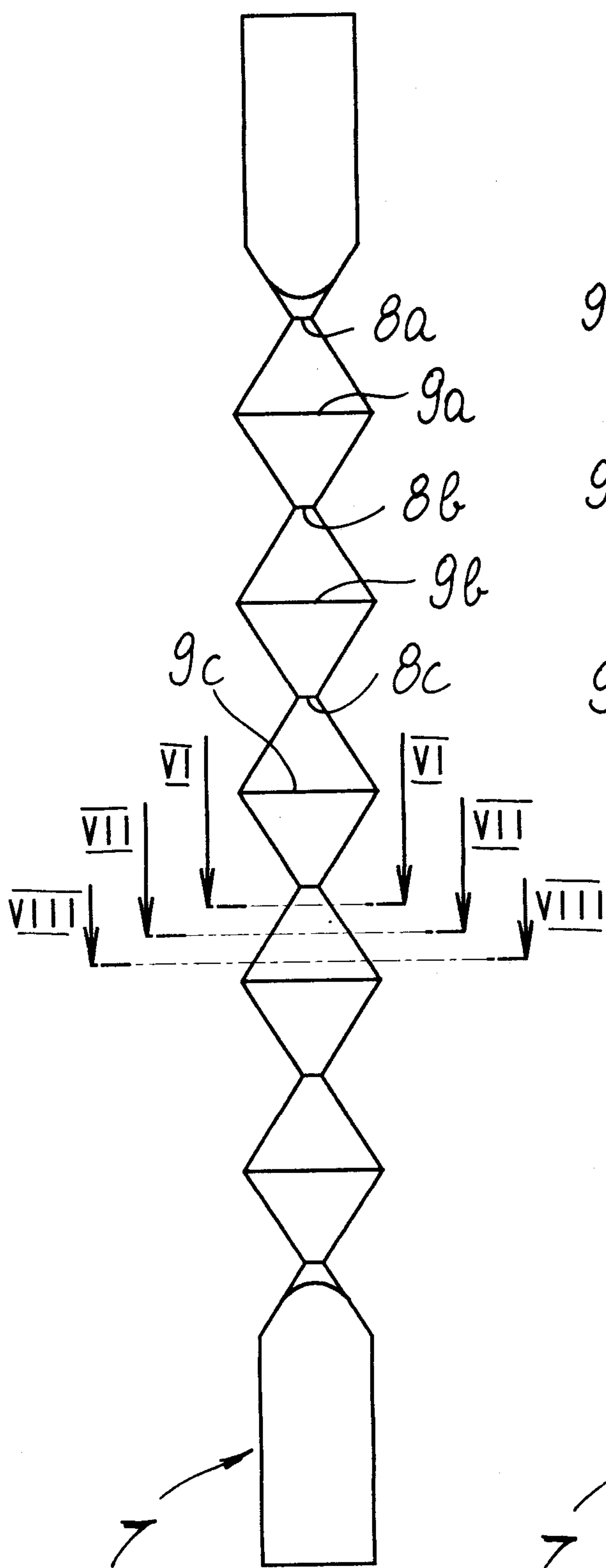

Fig. 3

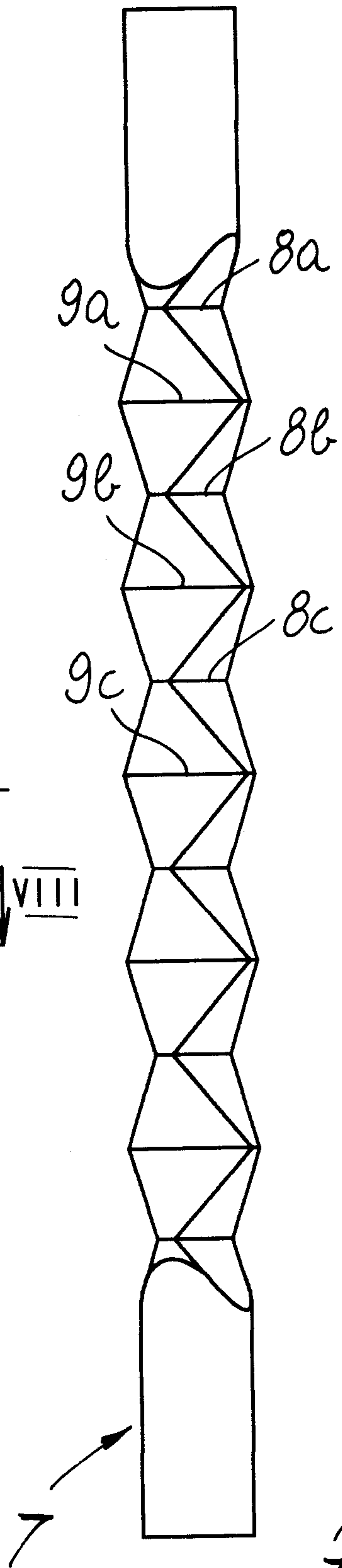

Fig. 4

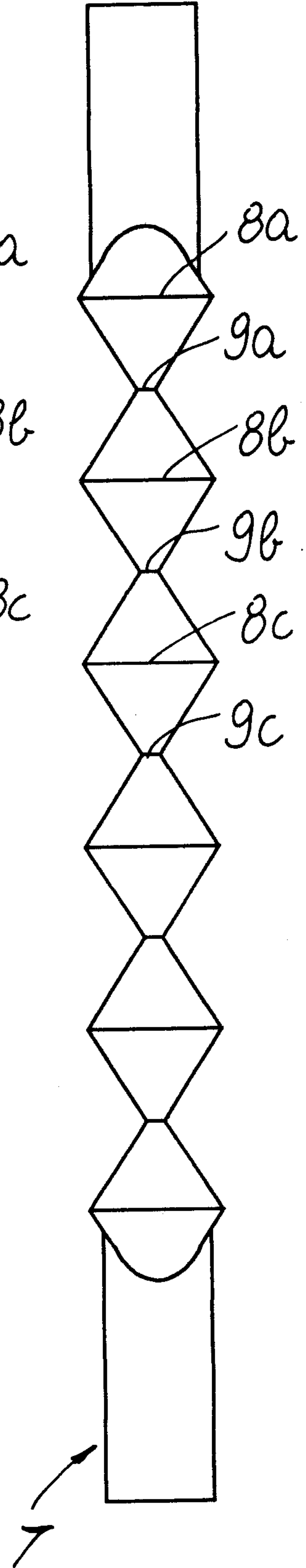

Fig. 5

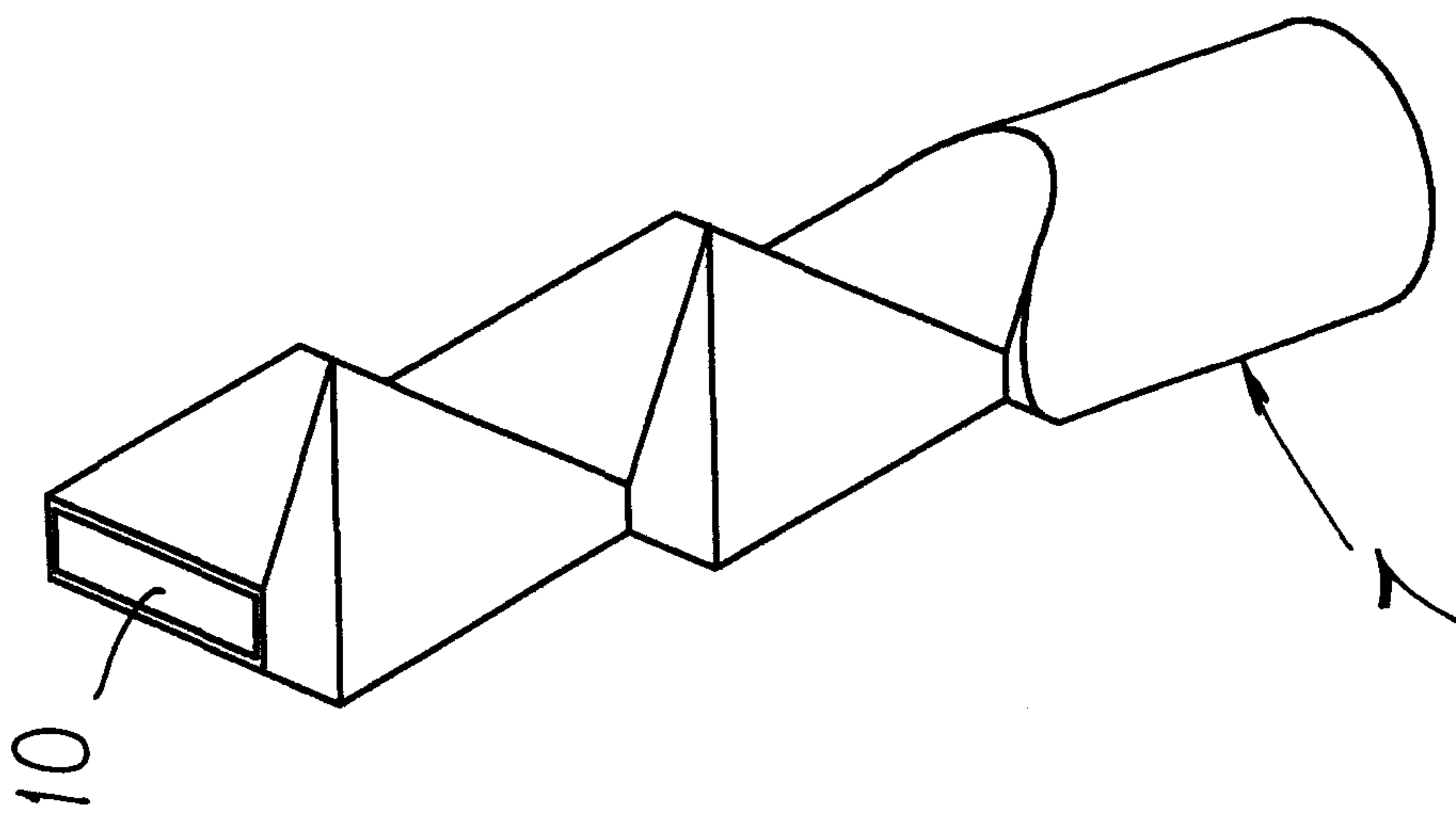

FIG. 6

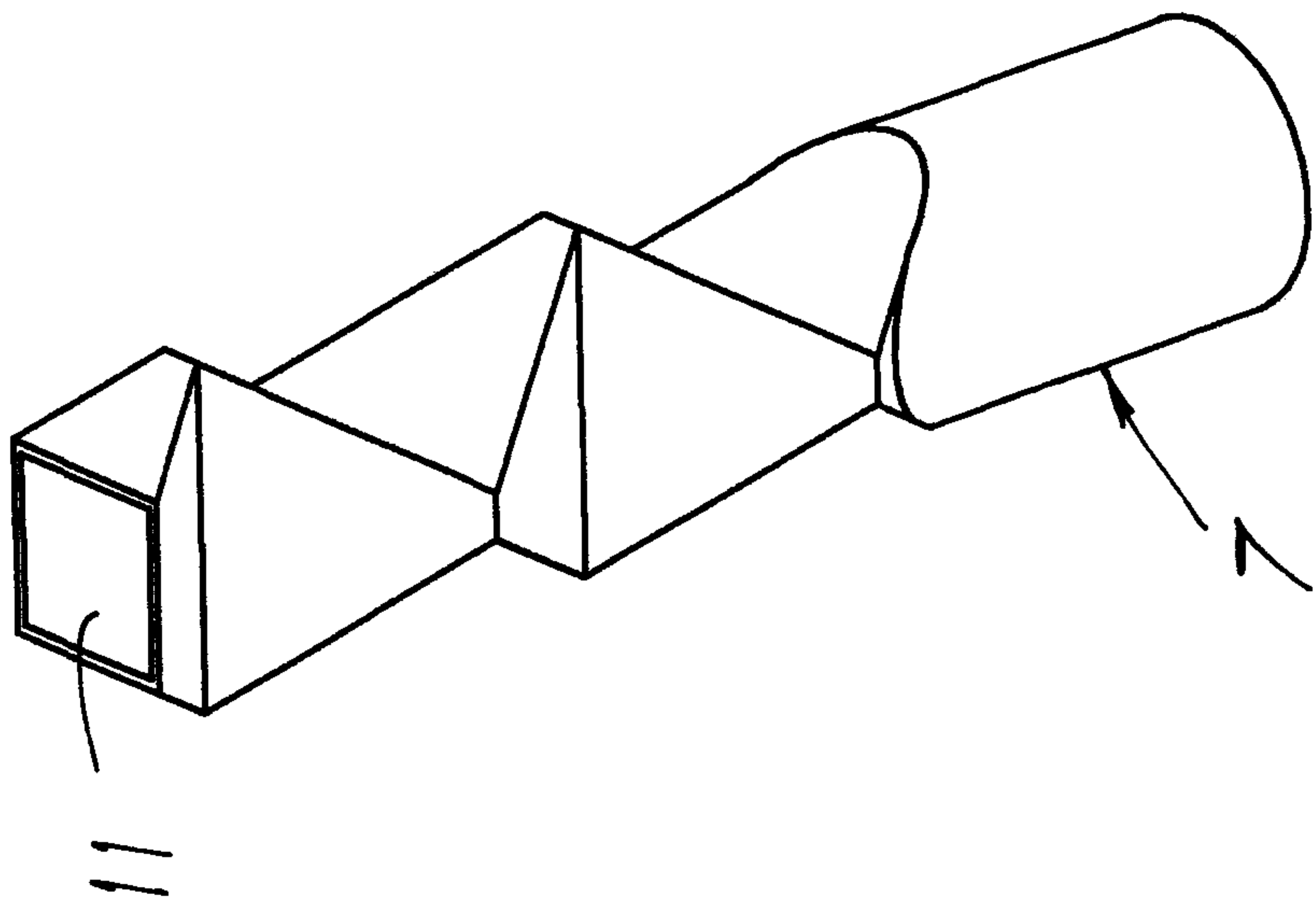

FIG. 7

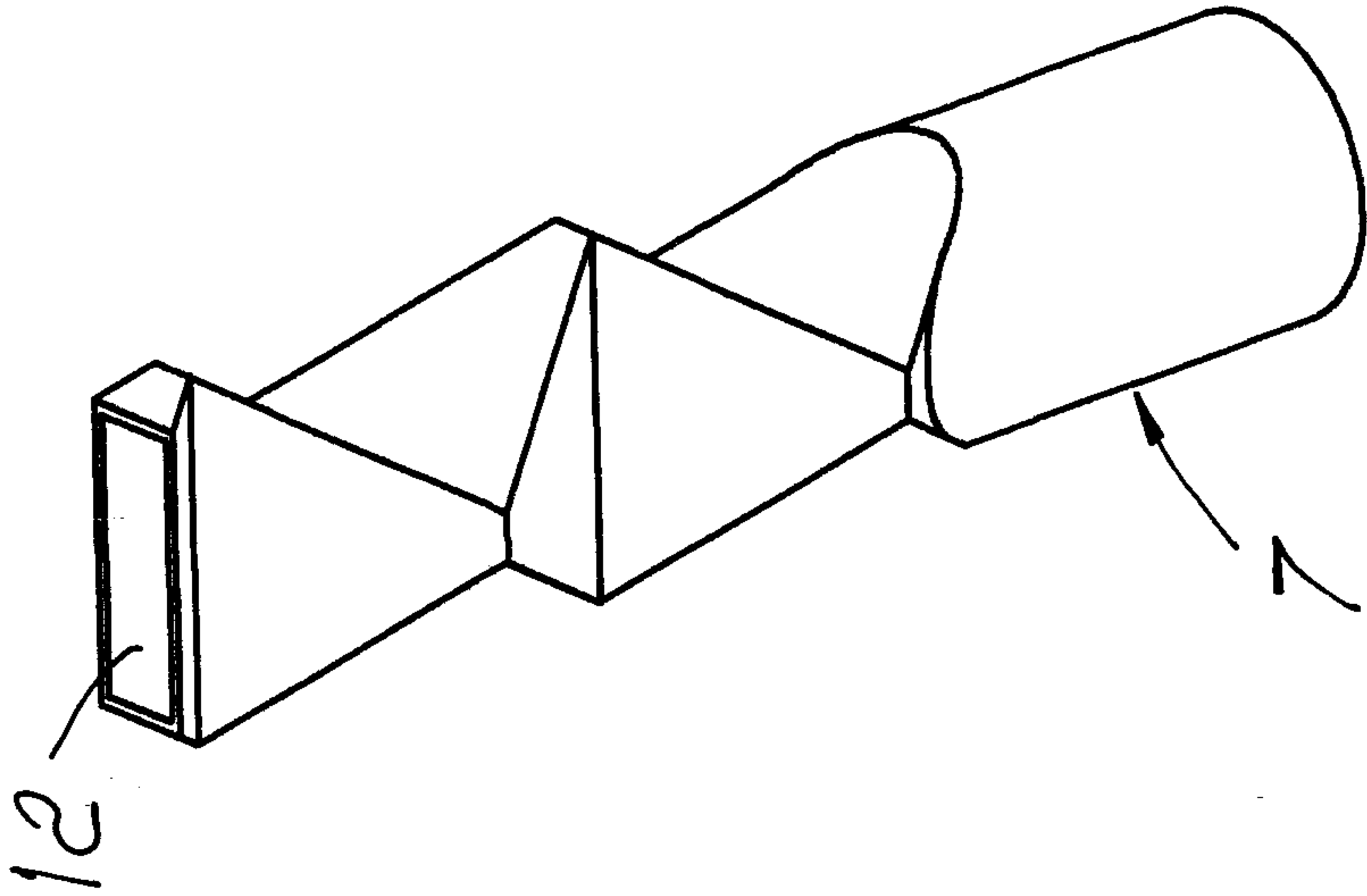

FIG. 8

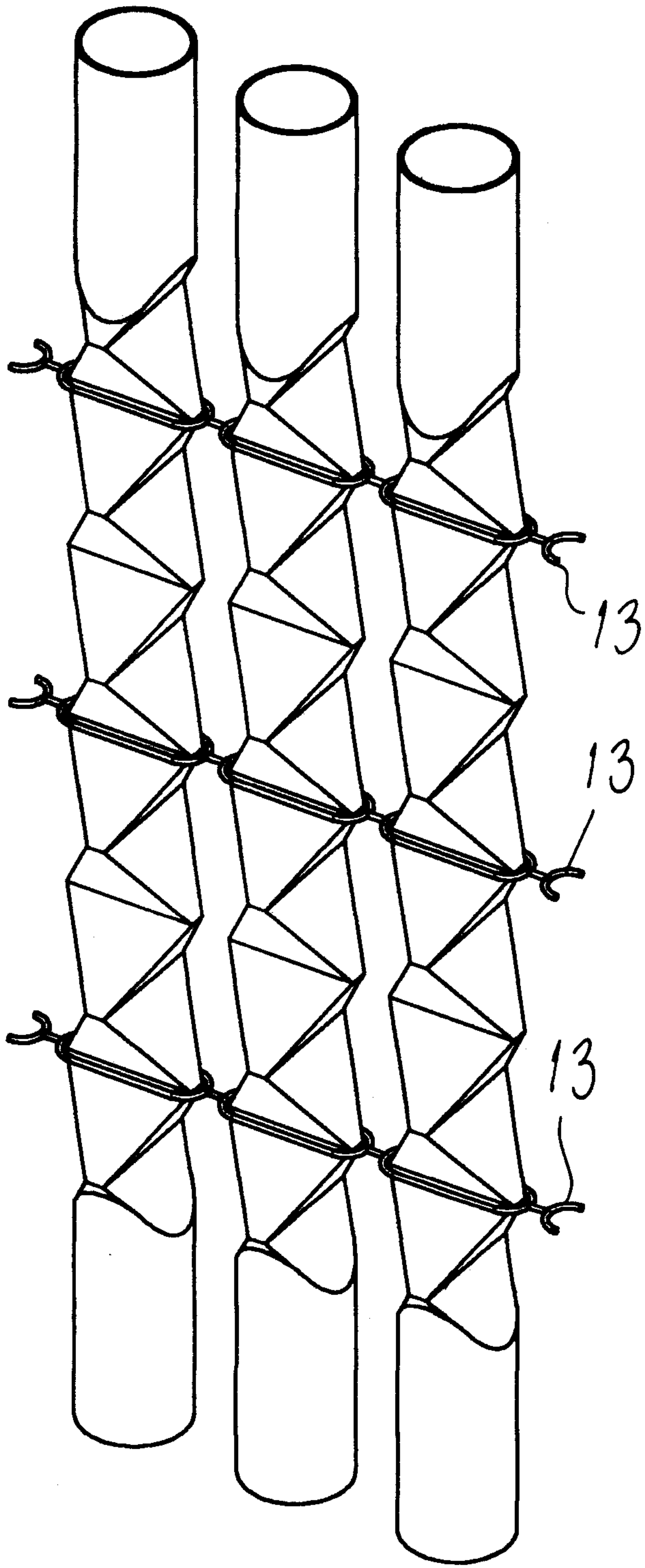

Fig. 9

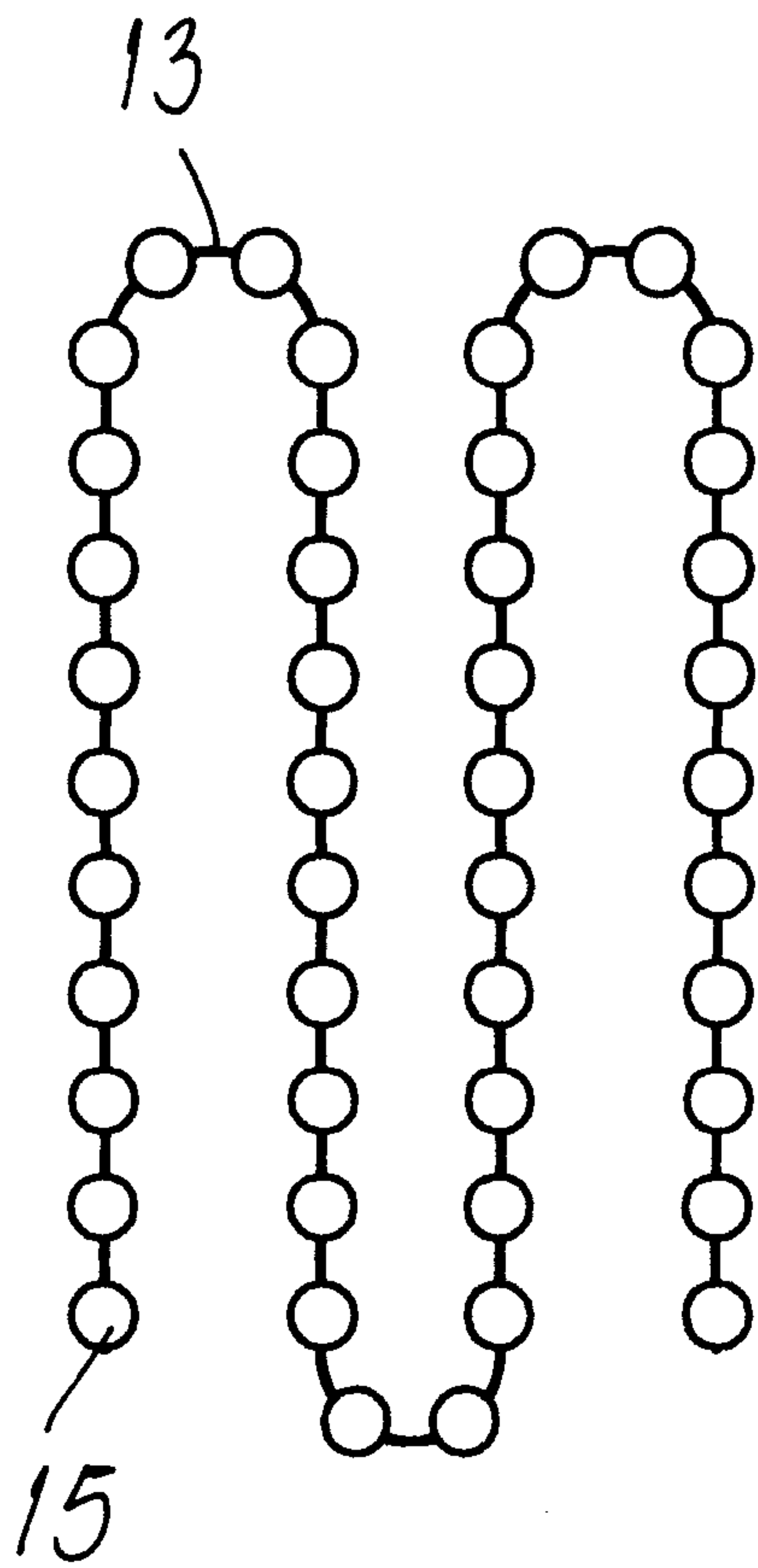
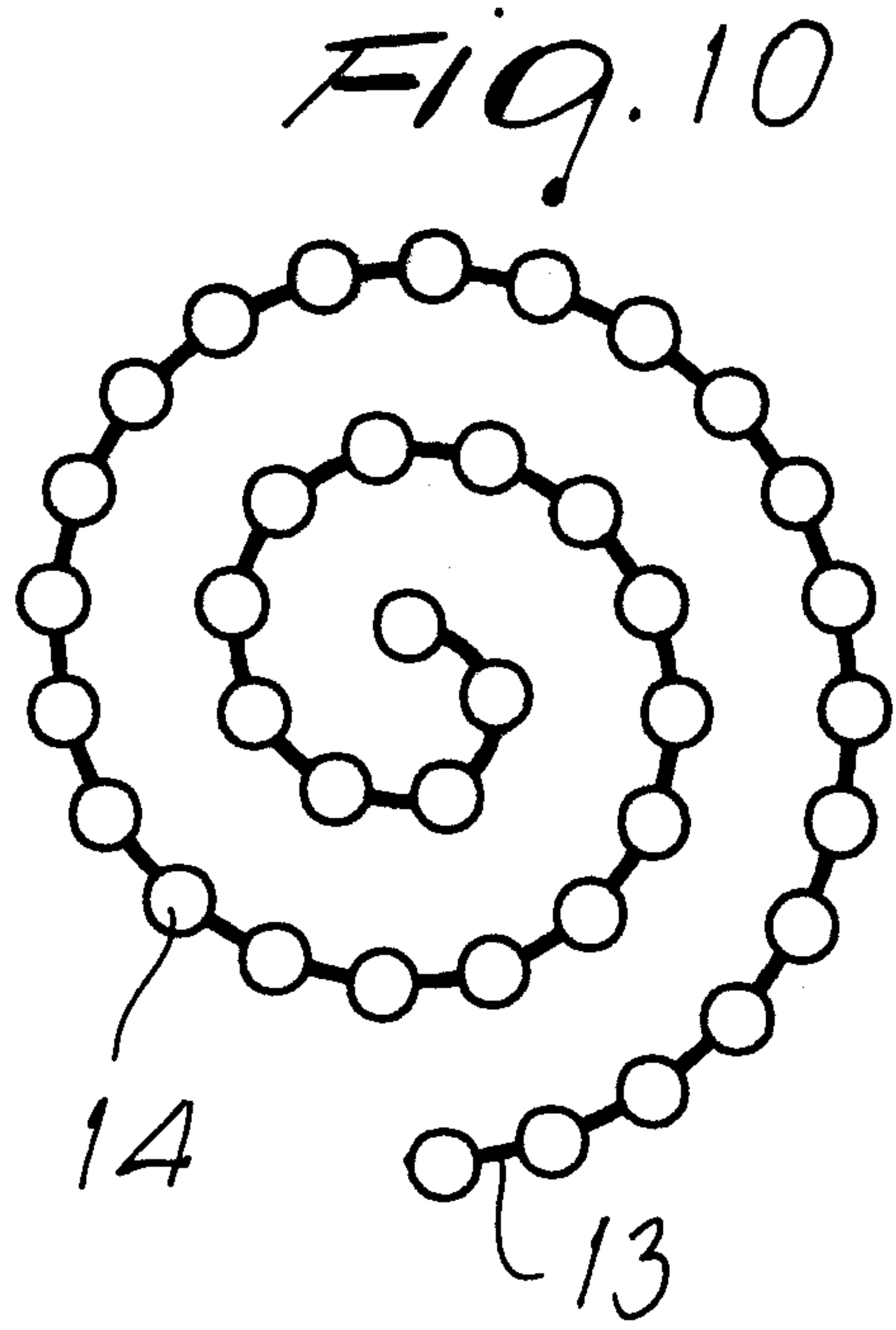

Fig. 11

