

E. F. Wilder.

Oil Can.

N^o 101,069

Patented Mar. 22. 1870.

Fig. 1.

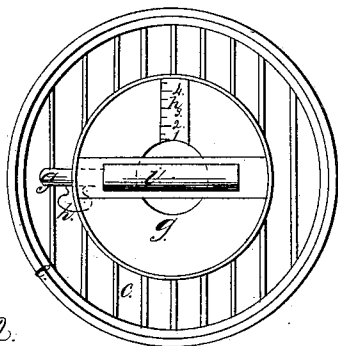

Fig. 2.

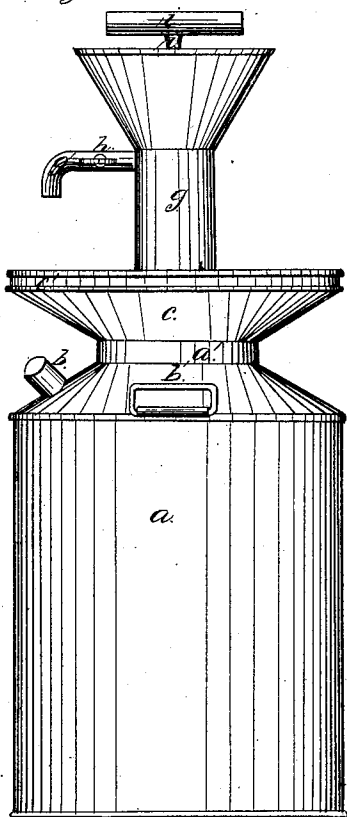
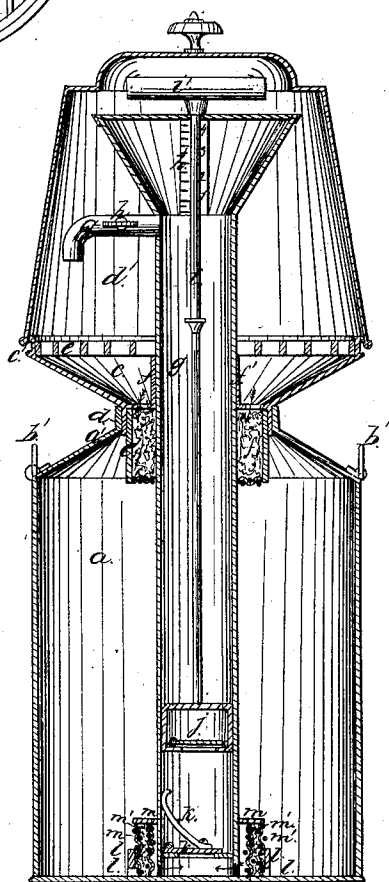

Fig. 3.



Witnesses:
J. F. Gladwin
George E. Peery,

Inventor:
Eli S. Wilder.

United States Patent Office.

ELI F. WILDER, OF LOWELL, MASSACHUSETTS.

Letters Patent No. 101,069, dated March 22, 1870; antedated September 22, 1869.

IMPROVEMENT IN APPARATUS FOR MEASURING LIQUIDS.

The Schedule referred to in these Letters Patent and making part of the same.

To all whom it may concern:

Be it known that I, ELI F. WILDER, of Lowell, in the county of Middlesex and State of Massachusetts, have invented new and useful Improvements in Oil-Cans; and I do hereby declare that the following is a full and exact description thereof, reference being had to the accompanying drawings and to the letters of reference marked thereon.

The nature of my invention consists in the arrangement and construction of the receiver or oil-can, whereby the user is enabled to accurately measure the oil drawn from the same, and at the same time, during the operation of drawing, the oil is completely filtered and cleansed from all particles of dirt, dust, &c., and the interior of the can is kept perfectly clean.

To enable others skilled in the art to make and use my invention, I will proceed to describe its construction and operation.

Figure 1 represents a plan of my improved oil-can with the cover removed.

Figure 2 represents a side elevation of the same.

Figure 3 represents a vertical section showing the can complete and its working parts.

Similar letters in the different figures indicate corresponding parts.

a represents the can or receiver, which is made of the required common size and shape, its body being straight, and contracted at the top, and provided with a suitable flange which forms the neck *a'* of the same.

The top of the can *a* is further provided with a filling inlet, *b*, and handles *b' b'* for carrying or moving the same.

Connecting with and fitting in the neck *a'* is the tunneled gatherer *c*, provided with top and bottom flanges *c'* and *d*.

The top flange *c'* serves to hold the cover *d'* and rack *e*.

The bottom flange *d* fitting in the neck *a'* receives the filter-cup *e'*, its bottom being constructed of gauze and filled with a suitable filtering material, *f*.

Through the bottom of the gatherer *c* is a sufficient number of holes or ducts, as indicated by arrows in the drawings, for the escape of the waste or excess of oil, and it is provided with a tube or bearing, *f'*, which prevents the waste oil from passing into the receiver *a*, except through the filter-cup *e'* and serves also for a top bearing for the pump *g*. This pump is provided with a nose *g'*, which has a suitable stop-cock, *h*. The top of the pump *g* is in form of a tunnel and its inside provided with a figured gauge *h'*, which accurately indicates and measures the quantity of oil required, at any given time drawn from the receiver *a*, measurement being reckoned and started from the nose *g'* to the top of the pump *g*. The top of the pump

g is also provided with a cross-bar, which strengthens the same, and accommodates, by furnishing a bearing for the piston *i*, which is supplied with a handle, *i'*, at the top. At the bottom is a common pump-box, *j*, which fits nicely and works in the interior of the pump *g*. The bottom of the pump is provided with a stationary box, *j'*, its valve *k* being furnished with a spring, *k'*, which serves to keep the valve *k* closed when the pump-box *j* descends. Connected to the bottom, in the inside of the receiver or can *a*, is an annular flange, *l*, which is perforated with holes or conducting ducts *l' l'*.

This flange *l* receiving the filter-cup *m*, the barrel of which being formed of two annular rings of wire gauze *m' m'*, between which is filled with filtering material *n*, leaving a vacuum between the pump *g* and the inner gauze lining.

Operation.

The oil-can being thus constructed and its several parts adjusted in their respective places, is then ready for use.

The can *a* being filled with oil, which may be done through the inlet *b*, or with greater facility by removing the pump *g* from the receiver or can *a* and inserting it in the barrel containing the oil, and attaching a pipe or hose to the nose *g'* of the pump *g*, and connecting with the inlet *b* of the can *a*. In either case, when filled and the pump *g* being in position in the can *a*, the operator, if required to fill a vessel without measurement, operates the pump *g* by aid of the handle *i'*, drawing the piston *i* upward in the usual way, alternately, until the required quantity is drawn from the can *a* into the same.

If an accurate measurement or a given quantity of oil is to be drawn the cock *h* is closed, the piston *i* is operated as before until the oil rises in the tunneled part of the pump *g* to the required given point or figure on the gauge *h'*, which indicates the exact quantity of oil required. The cock *h* is then opened, and this quantity of oil is allowed to discharge through the nose *g'* into its previously prepared vessel.

In both, or either case, the oil is compelled to pass through the filtering-cup *m* before entering the pump *g*, thus completely purifying and cleansing the oil from all particles of dirt, impurities and settlings, which always are deposited on the bottom of cans before being discharged from the pump *g*, and also prevents much of the usual and ordinary wear of the boxes *j* and *j'*, whilst in operation.

The escape and waste of oil, occasioned through carelessness or otherwise whilst drawing the oil from the pump *g* through the nose *g'*, is conveyed to the filter-cup *e'* by aid of the gatherer *c*, where it passes through the filtering material *f* into the receiver or

can *g*, thus effectually filtering this excess and waste from all impurities before passing into the same, which may have collected on the vessel filled.

The pump *g*, gatherer *c*, and filterers *e'* and *m* are so constructed as to be adapted and operated in the cans now in use, thus obviating the unnecessary expense of new receivers or cans.

Thus, it will be seen by the use of my improved oil-can with its new arrangement and construction of devices, saves to the user the entire cost and space of a full set of measuring vessels, a perfect purifier from all particles of dirt, settlings, and sediment to oils, rendering them clean and pure, thus increasing the

value of the same for illuminating or lubricating purposes, besides saving the constant usual waste and trouble attending the same.

What I claim as my invention, and desire to secure by Letters Patent, is—

The filter-cups *m* and *e'* and gatherer *c*, in combination with the pump *g*, when arranged substantially as and for the purposes herein described.

ELI F. WILDER.

Witnesses:

S. F. GLADWIN,
GEORGE E. PEVEY.