

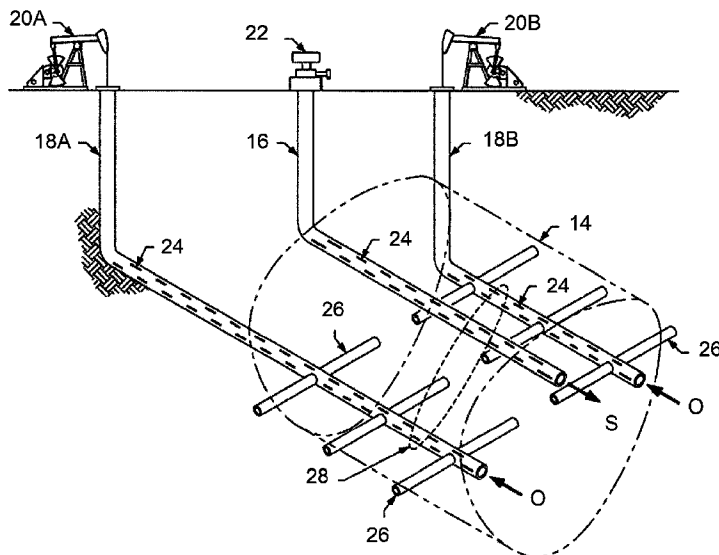

(22) Date de dépôt/Filing Date: 2016/09/23
 (41) Mise à la disp. pub./Open to Public Insp.: 2017/03/23
 (45) Date de délivrance/Issue Date: 2022/03/08
 (30) Priorité/Priority: 2015/09/23 (US62/222,543)

(51) Cl.Int./Int.Cl. *E21B 43/24* (2006.01),
E21B 43/30 (2006.01), *C09K 8/592* (2006.01)
 (72) Inventeurs/Inventors:
 FILATYEV, SERGEI A., US;
 GOVIND, PRADEEP ANANTH, CA;
 WHEELER, THOMAS J., US
 (73) Propriétaire/Owner:
 CONOCOPHILIPS COMPANY, US
 (74) Agent: OYEN WIGGS GREEN & MUTALA LLP

(54) Titre : CONDITIONNEMENT THERMIQUE D'ARRETES DE POISSON
 (54) Title: THERMAL CONDITIONING OF FISHBONES



(57) Abrégé/Abstract:

The present disclosure relates to a particularly effective well configuration that can be used for SAGD and other steam based oil recovery methods. Fishbone multilateral wells are combined with SAGD, effectively expanding steam coverage, but the fishbones are preheated to mitigate plugging problems, with e.g., resistive heating, EM heating or chemical heating.

ABSTRACT

The present disclosure relates to a particularly effective well configuration that can be used for SAGD and other steam based oil recovery methods. Fishbone multilateral wells are combined with SAGD, effectively expanding steam coverage, but the fishbones are preheated to mitigate plugging problems, with e.g., resistive heating, EM heating or chemical heating.

THERMAL CONDITIONING OF FISHBONES

FIELD OF THE INVENTION

[0001] This invention relates generally to well configurations that can advantageously produce oil using steam-based mobilizing techniques, and their pretreatment to prevent bitumen plugging.

BACKGROUND OF THE INVENTION

[0002] Many countries in the world have large deposits of oil sands, including the United States, Russia, and the Middle East, but the world's largest deposits occur in Canada. Oil sands are a type of unconventional petroleum deposit. The sands contain naturally occurring mixtures of sand, clay, water, and a dense and extremely viscous form of petroleum technically referred to as "bitumen," but which may also be called heavy oil or tar. At room temperature, bitumen is much like cold molasses. Often times, the viscosity can be in excess of 1,000,000 cP.

[0003] Due to their high viscosity, these heavy oils are hard to mobilize, and they generally must be made to flow in order to produce and transport them. Methods for mobilizing heavy oil have been previously established, and include, but are not limited to, the addition of gases, solvents, and energy, individually or in combination. However, Steam Assisted Gravity Drainage or "SAGD" is the most extensively used technique for *in situ* recovery of bitumen resources in the McMurray Formation in the Alberta Oil Sands.

[0004] In a typical SAGD process, shown in FIG. 1, two horizontal wells are vertically spaced by 4 to 10 meters (m) in the oil sands layer. The production well 10 is located near the bottom of the pay and the steam injection well 12 is located directly above and parallel to the production well 10. In SAGD, steam is injected continuously into the injection well 12, where it rises in the reservoir and forms a steam chamber.

[0005] With continuous steam injection, the steam chamber will continue to grow upward and laterally into the surrounding formation. At the interface between the steam chamber and cold oil, steam condenses and heat is transferred to the surrounding oil. This heated oil

becomes mobile and drains, together with the condensed water from the steam, into the production well due to gravity segregation within steam chamber.

[0006] This use of gravity gives SAGD an advantage over conventional steam injection methods. SAGD employs gravity as the driving force and the heated oil remains warm and movable when flowing toward the production well. In contrast, conventional steam injection displaces oil to a cold area, where its viscosity increases and the oil mobility is again reduced.

Conventional SAGD tends to develop a cylindrical steam chamber with a somewhat tear drop or inverted triangular cross section. With several SAGD well pairs operating side by side, the steam chambers tend to coalesce near the top of the pay, leaving the lower “wedge” shaped regions midway between the steam chambers to be drained more slowly, if at all. Operators may install additional producing wells in these midway regions to accelerate recovery and such wells are called “infill” wells, filling in the area where oil would normally be stranded between SAGD well-pairs (e.g., US20130008651).

[0007] Although quite successful, SAGD does require enormous amounts of water in order to generate a barrel of oil. Some estimates provide that 1 barrel of oil from the Athabasca oil sands requires on average 2 to 3 barrels of water (cold water equivalent) and as many as 7 barrels, although with recycling the total amount can be reduced to 0.5 barrel. In addition to using a precious resource, additional costs are added to convert those barrels of water to high quality steam for downhole injection. Therefore, any technology that can reduce water or steam consumption has the potential to have significant positive environmental and cost impacts.

[0008] One concept for improving production is the “multilateral” or “fishbone” well configuration idea. The concept of fishbone wells for non-thermal horizontal wells was developed by Petrozuata in Venezuela starting in 1999. That operation was a cold, viscous oil development in the Faja del Orinoco Heavy Oil Belt. The basic concept was to drill open-hole side lateral wells or “ribs” off the main spine of a producing well prior to running slotted liner into the spine of the well. Such ribs appeared to significantly contribute to the productivity of the wells when compared to wells without the ribs in similar geology.

[0009] The advantages of multilateral wells can include:

[0010] Higher Production. In the cases where thin pools are targeted, vertical wells yield small contact with the reservoir, limited to the reservoir thickness, which results in lower production. Drilling several laterals in thin reservoirs and increasing contact improves recovery. Slanted laterals can be of particular benefit in thin stacked pay zones.

[0011] Decreased Water/Gas Coning. By increasing the length of “wellbore” in a horizontal strata, the inflow flux around the wellbore can be reduced. This allows a higher withdrawal rate with less pressure gradient around the producer. Coning is aggravated by pressure gradients that exceed the gravity forces that stabilize fluid contacts (oil/water or gas/water), so that coning is minimized with the use of multilaterals, which minimize the pressure gradient.

[0012] Improved sweep efficiency. By using multilateral wells, the sweep efficiency may be improved, and/or the recovery may be increased due to the additional area covered by the laterals.

[0013] Faster Recovery. Production from the multilateral wells is at a higher rate than that in single vertical or horizontal wells, because the reservoir contact is higher in multilateral wells.

[0014] Decreased environmental impact. The volume of consumed drilling fluids and the generated cuttings during drilling multilateral wells are less than the consumed drilling fluid and generated cuttings from separated wells, at least to the extent that two conventional horizontal wells are replaced by one dual lateral well and to the extent that laterals share the same mother-bore. Therefore, the impact of the multilateral wells on the environment can be reduced.

[0015] Saving time and cost. Drilling several laterals in a single well may result in time and cost saving in comparison with drilling several separate wells in the reservoir.

[0016] Although an improvement in some respects, the multilateral well methods have disadvantages too. One disadvantage is that fishbone wells are more complex to drill and clean up. Another disadvantage is increased risk of accident or damage, due to the complexity of the operations and tools. Sand control can also be difficult. In drilling multilateral wells, the mother well bore can be cased to control sand production, however, the legs branched from the mother

well bore are open hole. Therefore, the sand control from the branches is not easy to perform. There is also increased difficulty in modeling and prediction due to the sophisticated architecture of multilateral wells.

[0017] One area of uncertainty with the fishbone concept is whether the ribs will establish and maintain communication with the offset steam chambers, or will the open-hole ribs collapse early and block flow. One of the characteristics of the Athabasca Oil Sands is that they are unconsolidated sands that are bound by the million-plus centipoises bitumen. When heated to 50-80°C the bitumen becomes slightly mobile. At this point the open hole rib could collapse. If so, flow would slow to a trickle, temperature would drop, and the rib would be plugged. However, if the conduit remains open at least long enough that the bitumen in the near vicinity is swept away with the warm steam condensate before the sand grains collapse, then it may be possible that a very high permeability, high water saturation channel might remain even with the collapse of the rib. In this case, the desired conduit would still remain effective.

[0018] Another uncertainty with many ribs along a fishbone producer of this type is that one rib may tend to develop preferentially at the expense of all the other ribs leading to very poor conformance and poor results. This would imply that some form of inflow control may be warranted to encourage more uniform development of all the ribs.

[0019] US application US20140345861 by ConocoPhillips took the fishbone concept and for the first time applied it to SAGD techniques, and showed several variations on the theme, which resulted in reduced startup time because the fishbones overlapped, or nearly so, such that the fishbone laterals contributed significantly to allowing early fluid communication. Application US20140345855 applied this idea to radial well configurations, thus minimizing wellpads.

[0020] In order to maximize bitumen recovery and reduce the amount of stranded resources, the fishbones need to be placed as low in the reservoir as possible, ideally at the same elevation of the offset producer well pair. However, our numerical simulations show that placing a fish bone so low results in cold bitumen filling and plugging the fishbone, preventing steam propagation in the fishbone and results in reduced performance relative to a conventional SAGD process.

[0021] Therefore, although beneficial, the multilateral well concept could be further developed to address some of these disadvantages or uncertainties. In particular, a method that combines multilateral well architecture with steam assisted processes would be beneficial, especially if such methods conserved the water, energy, and/or cost to produce a barrel of oil.

SUMMARY OF THE DISCLOSURE

[0022] The fishbone well concept for steam recovery methods was described in US20140345861 and US20140345855 and these methods are modified by supplementing the steam preheat with an additional heat source at the laterals in order to ensure adequate flow therein.

[0023] Typically, horizontal SAGD cased wellpairs (one injector and one producer) are placed at the base of the formation. Another cased producer is placed at a distance (normally about 50-100 meters away) parallel to the wellpair and is known as an “infill” well or “standalone producer” and serves to collect oil in the lost wedge between wellpairs.

[0024] Several uncased openhole wells "fish bones" that connect or nearly connect the wellpair and the standalone producer are drilled along the length of the wellpair. This well arrangement is designed to accelerate bitumen production and reduce the number of cased wells therefore reducing well costs and increasing the profitability of operations.

[0025] Injectors may be at the same depth or higher than the producers. Laterals nearly overlap, but typically are not connected to an adjacent well, but reach at least to the steam chamber. Laterals preferably originate at the producer (either the paired producer or standalone or both), but could be on the injectors or both injectors and producers.

[0026] Any steam injected into a well with laterals will also travel down the lateral. No effort needs be made to stop that flow. However, the standalone producer may be equipped with ICDs, ICVs or other steam control methods, to prevent steam flashing through to the standalone producer.

[0027] In order to maximize bitumen recovery and reduce the amount of stranded resources, the fishbone's need to be placed as low in the payzone reservoir as possible, ideally at the same elevation of the offset producer well pair. Our numerical simulations show that placing a fish bone so low results in cold bitumen filling and plugging the fishbone, preventing steam

propagation along the fishbone and resulting in reduced performance relative to a conventional SAGD process. However, our simulations also indicate that if the fishbone is preheated with an additional heat source at the same time as the wellpair during steam circulation period (normally 3-6 months before initiating SAGD, but can be less in fishbone operations), the plugging does not occur and the fishbone performs much better. Thus, some heat in addition to the typical steam preheat during startup is beneficial.

[0028] To preheat the fishbone, several techniques are proposed herein:

[0029] MicroWave/Radio-Frequency (MW/RF) heating: Place particles susceptible to MW/RF heating inside the fishbone during or right after drilling, apply MW/RF radiation to the particles and heat them while the main SAGD wellpair is in the circulation period.

[0030] Of course, the well will need to be fitted with antenna so that the RF or MW waves could be applied thereto and the extra equipment and facilities may make this less economic than other methods. There are many patents describing how to apply electromagnetic energy to wellbores, downhole antennae, and susceptors, including US8729440, US8936090, US8960286, US20120305239, US20140266951, US20140266951, US8674274, US8133384, US20120085533, US8128786, US8783347, US5082054, US8337769, US8646527, US20140131044, US8772683, and the like.

[0031] Resistive Heating: Place conductive material with high resistivity inside the fishbone during or right after drilling, apply voltage across the fishbone and heat the material while the main wellpair is in the circulation period.

[0032] As above, there are several patents directed to resistive heating in wellbores, including US5621844, US6353706, US7165607, US6942032, and the like.

[0033] Inductive heating: Another electrical method of heating wellbores is inductive heat. US6285014 and US6353706 describes such a tool. However, such methods may only be applicable to cased laterals.

[0034] Chemical Heating: In this context, chemical pellets are introduced into the fishbone during or right after drilling. During the steam circulation preheating period, the pellets undergo chemical reaction, generating heat in the open hole fishbone. One example is to use coated elemental sodium pellets.

[0035] There are patents describe chemical heating downhole, including e.g., US20060081374, US8691731, US20150000912, WO2013130361, and the like.

[0036] The methods described herein add additional heat, beyond what may be quickly achieved with the typical steam startup procedure, thus ensuring that the laterals are warmed, and fully available to allow flow therethrough on the commencement of production. This is particularly beneficial where startup period is reduced because it is easier to achieve fluid communication with the use of nearly overlapping laterals, and the reduced startup period is thus insufficient to heat the length of the lateral, especially when low in the pay.

[0037] The disclosure relates to well configurations that are used to improve steam recovery of oil, especially heavy oils. In general, fishbone wells replace conventional wellbores in SAGD operations. Either or both injector and producer wells are multilateral, and preferably the arrangement of lateral wells, herein called “ribs” is such as to provide overlapping coverage of the pay zone between the injector and producer wells. However, in the methods herein described, the laterals are preheated thus mitigating any risk of plugging the laterals with cold bitumen.

[0038] Where both well types have laterals, a pair of ribs can cover or nearly cover the distance between two wells, but where only one of the well types is outfitted with laterals, the lateral length can be doubled such that the single rib covers most of the distance between adjacent wells. It is also possible for laterals to intersect with each other or with one of the main wellbores, but this is not necessary.

[0039] The density and lengths of open-hole ribs may be varied to suit the particular environment, but, as noted, preferably they nearly reach, reach and/or extend beyond an opposing rib originating from an adjacent wellbore or reach or nearly reach an adjacent wellbore.

[0040] Also the spacing between injectors and producers, both vertically and laterally, in the pay section may be optimized for the particular reservoir conditions. The open-hole ribs may be horizontal, slanted, or curved in the vertical dimension to optimize performance. Where pay is thin, horizontal laterals may suffice, but if the pay is thick and/or there are many stacked thin pay zones, it may be beneficial to combine horizontal and slanted laterals, thus contacting more of the pay zone.

[0041] With sufficient lateral well coverage, it may be possible to significantly reduce conventional steam circulation for startup that is required for conventional SAGD, especially where lateral well coverage reaches from the production wells to the injector wells, thus establishing immediate or nearly immediate fluid communication. However, the lateral preheat is still beneficial for optimal performance of the laterals.

[0042] Flow distribution control may be used in either or both the injectors and producers to further optimize performance along all the ribs instead of the ones closer to the heel, and to potentially lower the development cost. In a preferred embodiment, the standalone producer is equipped with ICDs.

[0043] Such wells can be placed as infill wells or well pairs between conventional SAGD well pairs or used entirely independently of conventional SAGD well pairs.

[0044] With the fishbone SAGD methodology described herein, the injection wells may or may not be placed directly vertically above the producing well. In particular, a preferred embodiment may be to place the injectors and producers laterally apart by 50 to 150 meters, using the lateral wells to bridge the steam gaps. Combinations of lateral and vertical spacing may also be used.

[0045] The invention can comprise any one or more of the following embodiments, in any combination:

[0046] —A method steam assisted gravity drainage (SAGD) production of hydrocarbons, comprising:

[0047] providing a plurality of horizontal production wells at a first depth at or near a bottom of a hydrocarbon play;

[0048] providing a plurality of horizontal injection wells, each injection well laterally spaced at a distance D from an adjacent production well;

[0049] providing a plurality of lateral wells originating from at least some of said horizontal production wells or horizontal injection wells or both, wherein said plurality of lateral wells cover at least 90% of said distance D;

[0050] preheating a reservoir by injecting steam into all wells to establish fluid communication between said injection wells and said production wells;

- [0051] preheating said plurality of lateral wells using electromagnetic heating, resistive heating, or chemical heating;
- [0052] continuing steam injection in said injection wells only, and simultaneously producing mobilized heavy oil from said production wells.
- [0053] —A method for steam production of hydrocarbons, comprising:
- [0054] providing a plurality of wellpairs in a heavy oil reservoir, each wellpair including a horizontal production well at a bottom of a heavy oil payzone and a horizontal injection well above said horizontal production well;
- [0055] providing a standalone horizontal production well flanking each wellpair, said standalone horizontal production well being at or near said bottom or said heavy oil payzone and at a lateral distance D from a nearest wellpair;
- [0056] providing a plurality of lateral wells originating from one or both of adjacent horizontal production wells such that said lateral wells extend over at least 90% of said first distance D between adjacent wells;
- [0057] preheating said wellpair by injecting steam into all wells until fluid communication is established between said wellpair and preheating said lateral wells using electromagnetic (EM) heating, resistive heating or chemical heating;
- [0058] continuing steam injection only in said injection wells after said preheating step, and simultaneously producing mobilized heavy oil from said production wells.
- [0059] —An improved method of fishbone SAGD comprising a plurality of horizontal production wells, and a plurality of horizontal injection wells, said production wells having a plurality of lateral wells, wherein steam is injected into all wells during a startup period until fluid communication is established, then steam is injected only into injection wells during a production period and mobilized oil is produced from said production wells, the improvement comprising preheating said lateral wells with resistive heating, EM heating or chemical heating before commencing said production period.
- [0060] —A method as herein described, wherein each injection well is part of a wellpair, being directly over a horizontal producer well.

[0061] —A method as herein described, wherein each injection well is laterally spaced apart from a nearest producer well.

[0062] —A method as herein described, wherein said plurality of lateral wells originate from every horizontal production well or every other production well and cover at least 95% or 98% or 100% of said distance D.

[0063] —A method as herein described, wherein said plurality of lateral wells are arranged in an alternating pattern.

[0064] —A method as herein described, wherein each injection well is about at said first depth.

[0065] —A method as herein described, wherein each injection well is at a lesser depth (higher) than said first depth, or wherein each injection well is 4-10 meters higher than said first depth.

[0066] —A method as herein described, wherein said distance D is at least 50 meters, 100, 150 or more.

[0067] —A method as herein described, wherein said lateral wells extend over at least 95% or 98% or 100% of said first distance D between adjacent wells.

[0068] —A method as herein described, wherein a standalone horizontal production well or a producer in a well pair, or both, are completed with passive inflow control devices. If desired, the injectors can also include passive ICDs.

[0069] —A method as herein described, wherein said EM heating uses a downhole antenna to heat susceptors in said lateral well, and an EM wavelength activates and heats said susceptors or wherein said EM heating uses a downhole antenna and an RF wavelength to heat susceptors in said lateral well.

[0070] —A method as herein described, wherein said resistive heating uses electric current and a conductive material in said lateral well, said electric current travelling through and heating said conductive material.

[0071] —A method as herein described, wherein said chemical heating uses a chemical pellet that exothermically reacts with water and wherein condensed steam is used to activate said chemical pellet.

[0072] “Vertical” drilling is the traditional type of drilling in oil and gas drilling industry, and includes well $< 45^\circ$ of vertical.

[0073] “Horizontal” drilling is the same as vertical drilling until the “kickoff point” which is located just above the target oil or gas reservoir (pay zone), from that point deviating the drilling direction from the vertical to horizontal. By “horizontal” what is included is an angle within $45^\circ (\leq 45^\circ)$ of horizontal.

[0074] “Multilateral” wells are wells having multiple branches (laterals) tied back to a mother wellbore (also called the “originating” well), which conveys fluids to or from the surface. The branch or lateral may be vertical or horizontal, or anything therebetween.

[0075] A “lateral” well as used herein refers to a well that branches off an originating well. An originating well may have several such lateral wells (together referred to as multilateral wells), and the lateral wells themselves may also have lateral wells. The laterals may also be called ribs or fishbones herein.

[0076] An “openhole well” as used herein means the well is not cased.

[0077] An “alternate pattern” or “alternating pattern” as used herein means that subsequent lateral wells alternate in direction from the originating well, first projecting to one side, then to the other.

[0078] As used herein a “slanted” well with respect to lateral wells, means that the well is not in the same plane as the kickoff point from the originating well, but travels upwards or downwards from same.

[0079] As used herein, “overlapping” multilateral wells, means the ends of lateral wells from adjacent wellbores nearly reach or even pass each other or the next adjacent main wellbore, when viewed from the top.

[0080] Overlapping lateral wells is one option, but it may be more cost effective to provide e.g., only producers with lateral wells. In such cases, the laterals can be made longer so as to reach or nearly reach or even intersect with an adjacent well. In this way, fewer laterals are

needed, but the reservoir between adjacent main wellbores is still adequately covered to enable efficient steam communication and good drainage.

[0081] By “nearly reach” we mean at least 90% of the distance between adjacent main wellbores is covered by a lateral or a pair of laterals.

[0082] By “main wellbores” what is meant are injector and producer wells. Producer wells can also be used for injection early in the process.

[0083] By “wellpair” what is meant is the traditional SAGD well pair with a horizontal injector over a horizontal producer.

[0084] By “standalone producer” what is meant is a production well, low in the pay that does not have an injector above it.

[0085] By “startup” what is meant is a period before production when **all** wells are fitted for injection. This is typically used in SAGD to establish fluid communication between wellpairs. Startup is typically 3 – 6 months, but may be significantly reduced with the use of fishbone wells.

[0086] By “preheating laterals” what is meant is that additional heat (beyond the usual steam startup heat) is supplied to the laterals, to ensure good flow of hydrocarbons therethrough.

[0087] By “SAGD” in the claims, we include any of the variations on SAGD so long as steam and gravity are used to some extent. Thus, solvent assisted SA-SAGD, gas-push SAGD, single well-SAGD, and the like are all included. Although we focus herein on steam-based processes, the invention can also be applied to other processes, such as combustion-based processes, solvent based processes, and the like.

[0088] The use of the word “a” or “an” when used in conjunction with the term “comprising” in the claims or the specification means one or more than one, unless the context dictates otherwise.

[0089] The term “about” means the stated value plus or minus the margin of error of measurement or plus or minus 10% if no method of measurement is indicated.

[0090] The use of the term “or” in the claims is used to mean “and/or” unless explicitly indicated to refer to alternatives only or if the alternatives are mutually exclusive.

[0091] The terms “comprise”, “have”, “include” and “contain” (and their variants) are open-ended linking verbs and allow the addition of other elements when used in a claim.

[0092] The phrase “consisting of” is closed, and excludes all additional elements.

[0093] The phrase “consisting essentially of” excludes additional material elements, but allows the inclusions of non-material elements that do not substantially change the nature of the invention.

[0094] The following abbreviations are used herein:

SAGD	Steam assisted gravity drainage
EM	Electromagnetic
RF	Radio frequency
MW	Microwave
FCD	Flow control device
ICD	Inflow control device
ICV	Interval control valve, an active flow control device

BRIEF DESCRIPTION OF THE DRAWINGS

[0095] FIG. 1 shows a conventional SAGD well pair.

[0096] FIG. 2 is a view of two producer wells having lateral openhole wells thereon (fishbones), with a higher injector well therebetween.

[0097] FIG. 3 shows a SAGD wellpair bracketed by a pair of standalone producer wells.

[0098] FIG. 4A-C shows variation in placement of lateral well depth, being at the same depth as the producer of the wellpair in A and somewhat higher in B. FIG. 4C is a horizontal plane view (top view) of both FIG 4A and B.

DETAILED DESCRIPTION

[0099] FIG. 2 is a view of two producer wells having lateral openhole wells thereon (fishbones), with a higher injector well therebetween. As seen in FIG. 2, an injector well 16 is arranged between two producer wells 18A, 18B. A pump jack 20A, 20B may be used to lift oil (O) out of the producer wells 18A, 18B. A Christmas tree 22 may be used to control the injection of steam (S) into the injector well 16. Each of the injector wells 16 and producer wells 18A, 18B have one or more slots 24 spaced-apart along a length of the wells 16, 18A, 18B to form slotted

wells 28. A plurality of open-hole lateral wells 26 may be arranged to originate from the producer wells 18A, 18B and/or injector well 16.

[00100] FIG. 3 shows a SAGD wellpair bracketed by a pair of standalone producer wells. As seen in referring to FIG. 3, an injector well 16 and a producer well 18A are bracketed by a pair of standalone producer wells 30A, 30B. A pump jack 20A, 20B may be used to lift oil (O) out of the standalone producer wells 30A, 30B. A Christmas tree 22A, 22B may be used to control the injection of steam (S) into the injector well 16 and to lift oil (O) out of the horizontal producer well 18A. Each of the injector wells 16, producer well 18A and standalone producer wells 30A, 30B have one or more slots 24 spaced-apart along a length of the wells 16, 18A, 30A, 30B to form slotted wells 28. A plurality of open-hole lateral wells 26 may be arranged to originate from the producer well 18A and/or injector well 16.

[00101] The following is a detailed description of the preferred method of the present invention. It should be understood that the inventive features and concepts may be manifested in other arrangements and that the scope of the invention is not limited to the embodiments described or illustrated. The scope of the invention is intended to only be limited by the scope of the claims that follow.

[00102] The present invention provides a novel fishbone SAGD method, which uses the “fishbone” SAGD configurations previously described, wherein injectors or producers or both are both fitted with a plurality of multilateral wells, and wherein the fishbones are preheated to mitigate plugging. Once the laterals are preheated and fluid communication is established, the enhanced oil recovery method precedes as normal.

[00103] Although particularly beneficial in gravity drainage techniques, this is not essential and the configuration and methods could be used for horizontal sweeps as well. The well configuration can be used in any enhanced oil recovery techniques, including cyclic steam stimulations, SAGD, expanding solvent SAGD, polymer sweeps, water sweeps, and the like.

[00104] The ribs can be placed in any arrangement known in the art, depending on reservoir characteristics and the positioning of nonporous rocks and the play. Ribs can originate from producers or injectors or both, but preferably originate from the producers. Ribs can be placed on each producer, but preferably are used every other producer. E.g., every producer in a wellpair or very standalone producer.

[00105] The ribs can be planar or slanted or both, e.g., preferably slanting upwards towards the injectors, where injectors are placed higher in the pay. However, injectors need not be higher in the pay with this method. Nonetheless, upwardly slanted wells may be desirable to contact more of a thick pay, or where thin stacked pay zones exist. Downwardly slanting wells may also be used in some cases. Combinations of planar and slanted wells are also possible.

[00106] The rib arrangement on a particular main well can be pinnate, alternate, radial, or combinations thereof. The ribs can also have further ribs, if desired.

[00107] The fishbones are preheated by one the following methods:

EM HEATING

[00108] Electromagnetic heating using microwaves (MW) or Radio-Frequency (RF) waves can be used, particularly where susceptors are placed inside the fishbone during or right after drilling. One applies MW/RF radiation to the susceptors, thus preheating them before commencing production, e.g., during the preheat period to establish fluid communication. If there is sufficient connate water in the laterals, the susceptor may be omitted, and water heating frequencies used instead.

[00109] By “susceptor” herein, what is meant is any material that absorbs the microwave or radio frequency(s) applied to the reservoir. Any susceptors can be used in the method. US8133384, for example, described carbon fiber susceptors that can be heated e.g., using 2450 MHz (microwave). Other examples of susceptor materials are disclosed in US5378879; US6649888; US6045648; US6348679; and US4892782.

[00110] It is known in the art how to arrange antennae for effective heating using electromagnetic heating. *See e.g.*, US20120085533 (CCS using RF); US8616273 (RF preheating and solvent extraction); US20120061080 (reheating steam); US8807220 (in situ upgrading using RF); US8729440 (RF heater); US20140110395 (RF heater).

[00111] In one exemplary embodiment, RF energy can be applied in a manner that causes the susceptor particles to heat by induction. Induction heating involves applying an RF field to electrically conducting materials to create electromagnetic induction. An eddy current is created when an electrically conducting material is exposed to a changing magnetic field due to relative motion of the field source and conductor; or due to variations of the field with time. This can

cause a circulating flow or current of electrons within the conductor. These circulating eddies of current create electromagnets with magnetic fields that opposes the change of the magnetic field according to Lenz's law. These eddy currents generate heat. The degree of heat generated in turn, depends on the strength of the RF field, the electrical conductivity of the heated material, and the change rate of the RF field. There can be also a relationship between the frequency of the RF field and the depth to which it penetrates the material; in general, higher RF frequencies generate a higher heat rate.

[00112] Induction RF heating can be for example carried out using conductive susceptor particles. Exemplary susceptors for induction RF heating include powdered metal, powdered iron (pentacarbonyl E iron), iron oxide, or powdered graphite. The RF source used for induction RF heating can be for example a loop antenna or magnetic near-field applicator suitable for generation of a magnetic field.

[00113] The RF source typically comprises an electromagnet through which a high-frequency alternating current (AC) is passed. For example, the RF source can comprise an induction heating coil, a chamber or container containing a loop antenna, or a magnetic near-field applicator. The exemplary RF frequency for induction RF heating can be from about 50 Hz to about 3 GHz. Alternatively, the RF frequency can be from about 10 kHz to about 10 MHz, 10 MHz to about 100 MHz, or 100 MHz to about 2.5 GHz. The power of the RF energy, as radiated from the RF source, can be for example from about 100 KW to about 2.5 MW, alternatively from about 500 KW to about 1 MW, and alternatively, about 1 MW to about 2.5 MW. Of course, the frequency is tailored to activate the particular susceptor or blend of susceptors used.

[00114] In another exemplary embodiment, RF energy can be applied in a manner that causes the susceptor particles to heat by magnetic moment heating, also known as hysteresis heating. Magnetic moment heating is a form of induction RF heating, whereby heat is generated by a magnetic material. Applying a magnetic field to a magnetic material induces electron spin realignment, which results in heat generation. Magnetic materials are easier to induction heat than non-magnetic materials, because magnetic materials resist the rapidly changing magnetic fields of the RF source. The electron spin realignment of the magnetic material produces hysteresis heating in addition to eddy current heating. A metal which offers high resistance has high magnetic permeability from 100 to 500; non-magnetic materials have a permeability of 1.

One advantage of magnetic moment heating can be that it can be self-regulating. Magnetic moment heating only occurs at temperatures below the Curie point of the magnetic material, the temperature at which the magnetic material loses its magnetic properties.

[00115] Magnetic moment RF heating can be performed using magnetic susceptor particles. Exemplary susceptors for magnetic moment RF heating include ferromagnetic materials or ferrimagnetic materials. Exemplary ferromagnetic materials include iron, nickel, cobalt, iron alloys, nickel alloys, cobalt alloys, and steel. Exemplary ferrimagnetic materials include magnetite, nickel-zinc ferrite, manganese-zinc ferrite, and copper-zinc ferrite. In certain embodiments, the RF source used for magnetic moment RF heating can be the same as that used for induction heating—a loop antenna or magnetic near-field applicator suitable for generation of a magnetic field, such as an induction heating coil, a chamber or container containing a loop antenna, or a magnetic near-field applicator.

[00116] The exemplary RF frequency for magnetic moment RF heating can be from about 100 kHz to about 3 GHz. Alternatively, the RF frequency can be from about 10 kHz to about 10 MHz, 10 MHz to about 100 MHz, or 100 MHz to about 2.5 GHz. The power of the RF energy, as radiated from the RF source, can be for example from about 100 KW to about 2.5 MW, alternatively from about 500 KW to about 1 MW, and alternatively, about 1 MW to about 2.5 MW.

[00117] In a further exemplary embodiment, the RF energy source and susceptor particles selected can result in dielectric heating. Dielectric heating involves the heating of electrically insulating materials by dielectric loss. Voltage across a dielectric material causes energy to be dissipated as the molecules attempt to line up with the continuously changing electric field.

[00118] Dielectric RF heating can be for example performed using polar, non-conductive susceptor particles. Exemplary susceptors for dielectric heating include butyl rubber (such as ground tires), barium titanate, aluminum oxide, or PVC. Water can also be used as a dielectric RF susceptor. Dielectric RF heating typically utilizes higher RF frequencies than those used for induction RF heating. At frequencies above 100 MHz an electromagnetic wave can be launched from a small dimension emitter and conveyed through space. The material to be heated can therefore be placed in the path of the waves, without a need for electrical contacts. For example, domestic microwave ovens principally operate through dielectric heating, whereby the RF

frequency applied is about 2.45 GHz. The RF source used for dielectric RF heating can be for example a dipole antenna or electric near field applicator.

[00119] An exemplary RF frequency for dielectric RF heating can be from about 100 MHz to about 3 GHz. Alternatively, the RF frequency can be from about 500 MHz to about 3 GHz. Alternatively, the RF frequency can be from about 2 GHz to about 3 GHz. The power of the RF energy, as radiated from the RF source, can be for example from about 100 KW to about 2.5 MW, alternatively from about 500 KW to about 1 MW, and alternatively, about 1 MW to about 2.5 MW.

RESISTIVE HEATING

[00120] For resistive heating, a conductive material with high resistivity is placed inside the fishbone during or right after drilling. Voltage is then applied across the fishbone, thus heating the material while the main wellpair is in the preheat stage.

[00121] *In situ* processes involving downhole heaters are described in a large number of publications, including US2634961; US2732195; US2780450; US2548360; US4716960; US5060287; US6023554; US6360819; and SPE-165323-MS. Indeed, SPE-165323-MS (2013) Hale, et al., History and Application of Resistance Electrical Heating in Downhole Oil Field Applications provides a discussion of resistive heat use downhole, and notes that engineers are now modeling reservoir stimulation for pilots in Alberta with heaters as long as 2300 meters, operating at 4160 Volts with output of up to 1000 watts per meter.

[00122] Preferred lateral heating methods include introducing conductive high resistivity material (i.e. metal proppants, materials in powder or granular form) to the fishbone, and applied voltage using the conductive materials as an electrical conduit inducing heating of the fishbone lateral. E.g., US8087460, US8168570, US3642066.

[00123] In one aspect, the material comprising the conductive granular material has an electrical resistivity of less than 0.0001 Ohm-meters. More preferably, the material comprising the granular material has an electrical resistivity of less than 0.000001 Ohm-meters. The electrically conductive granular material may include metal, metal coated particles, coke or graphite. In one embodiment, the granular material is comprised of a mixture of granular materials of differing electrical conductivity.

CHEMICAL HEATING

[00124] The fishbone can also be heated chemically, by introducing one or more compounds that react to produce heat in an exothermic reaction. In this context, chemical pellets are introduced into the fishbone during or right after drilling. During the steam circulation preheating period, the pellets undergo chemical transformation, releasing heat in the open hole fishbone thus achieving the preheating effect.

[00125] One example is to use coated elemental sodium pellets. The highly exothermic reaction of sodium with the in-situ formation water results in the liberation of large amount of heat which reduces oil viscosity and can potentially generate in-situ steam as well. The coating prevents instantaneous reaction of sodium with water right after placement of pellets in the fishbone. Instead, the coating will degrade over time, and the exothermic reaction with connate water or steam that has traveled through the fishbones will provide heat in the fishbones over a required period of time. Another important advantage of this process is the formation of sodium hydroxide, which reduces the interfacial tension at the bitumen interface and improves the recovery.

[00126] An alternative process can be carried out by displacement of carbon dioxide in a simultaneous injection of carbon dioxide and elemental sodium in a heavy oil reservoir. When sodium suspended in liquid carbon dioxide is injected into the reservoir, it will diffuse through the carrier phase and then interact with water, releasing heat resulting in oil viscosity reduction and enhanced mobility due to the combined benefit from carbon dioxide solubility and the exothermic reaction heat.

[00127] Other exothermic reactions are known. US20140090839, for example, describes injecting an aqueous composition comprising an ammonium containing compound and a nitrite containing compound into the reservoir; and then injecting an activator. The activator initiates a reaction between the ammonium containing compound and the nitrite containing compound, such that the reaction generates steam and nitrogen gas, increasing localized pressure and improving oil mobility.

[00128] Other examples include use of alkali metals such as potassium, lithium, and combustion with magnesium, metal alloys, calcium, iron, phosphorus, sulfur, solid propellants,

etc. Combustion of magnesium, calcium, iron, phosphorus, sulfur, and metal alloys will require injection of oxidizer such as air/oxygen. On the other hand, solid propellants contain both fuel and oxidizer and do not require any additional oxidizing agent.

[00129] REFERENCES:

[00130] CA2684049 Infill well methods for SAGD well heavy hydrocarbon recovery operations

[00131] EME 580 Final Report: Husain, et al., Economic Comparison of Multi-Lateral Drilling over Horizontal Drilling for Marcellus Shale Field (2011), available online at ems.psu.edu/~elsworth/courses/egee580/2011/Final%20Reports/fishbone_report.pdf

[00132] Hogg, C. 1997. Comparison of Multilateral Completion Scenarios and Their Application. Presented at the Offshore Europe, Aberdeen, United Kingdom, 9-12 September. SPE-38493-MS.

[00133] OTC 16244, Lougheide, et al. Trinidad's First Multilateral Well Successfully Integrates Horizontal Openhole Gravel Packs, OTC (2004).

[00134] petrowiki.org/Multilateral_completions

[00135] SPE 69700-MS, "Multilateral-Horizontal Wells Increase Rate and Lower Cost Per Barrel in the Zuata Field, Faja, Venezuela", March 12, 2001.

[00136] SPE-165323-MS (2013) Hale, et al., History and Application of Resistance Electrical Heating in Downhole Oil Field Applications

[00137] STALDER J.L., et al., Alternative Well Configurations in SAGD: Rearranging Wells to Improve Performance, presented at 2012 World Heavy Oil Congress [WHOC12], available online at osli.ca/uploads/files/Resources/Alternative%20Well%20Configurations%20in%20SAGD_WHO C2012.pdf

[00138] Technical Advancements of Multilaterals (TAML). 2008. Available at taml-intl.org/taml-background/

[00139] US20060081374 Process for downhole heating

[00140] US20110067858 Fishbone well configuration for in situ combustion

- [00141] US20120061080 Process for downhole heating
- [00142] US20120085533 Cyclic steam stimulation using RF
- [00143] US20120227966 In situ catalytic upgrading
- [00144] US20120247760 Dual injection points in SAGD
- [00145] US20120305239 Cyclic radio frequency stimulation
- [00146] US20130008651 Method for hydrocarbon recovery using SAGD and infill wells with RF heating
- [00147] US20140090839 Enhanced oil recovery by in-situ steam generation
- [00148] US20140110395 System including tunable choke for hydrocarbon resource heating and associated methods
- [00149] US20140131044 Hydrocarbon resource heating device including superconductive material RF antenna and related methods
- [00150] US20140266951 Subsurface antenna for radio frequency heating
- [00151] US20140345855 Radial Fishbone SAGD
- [00152] US20140345861 Fishbone SAGD
- [00153] US20150000912 In-situ downhole heating for a treatment in a well
- [00154] US2548360 Electric oil well heater
- [00155] US2634961 Method of electrothermal production of shale oil
- [00156] US2732195 Method of treating oil shale and recovery of oil and other mineral products therefrom
- [00157] US2780450 Method of recovering oil and gases from non-consolidated bituminous geological formations by a heating treatment in situ
- [00158] US3642066 Electrical method and apparatus for the recovery of oil
- [00159] US4716960 Method and system for introducing electric current into a well
- [00160] US4892782 Fibrous microwave susceptor packaging material

- [00161] US5060287 Heater utilizing copper-nickel alloy core
- [00162] US5082054 In-situ tuned microwave oil extraction process
- [00163] US5378879 Induction heating of loaded materials
- [00164] US5621844 Electrical heating of mineral well deposits using downhole impedance transformation networks
- [00165] US6023554 Electrical heater
- [00166] US6045648 Thermoset adhesive having susceptor particles therein
- [00167] US6285014 Downhole induction heating tool for enhanced oil recovery
- [00168] US6348679 RF active compositions for use in adhesion, bonding and coating
- [00169] US6353706 Optimum oil-well casing heating
- [00170] US6360819 Electrical heater
- [00171] US6649888 Radio frequency (RF) heating system
- [00172] US6942032 US7165607 Resistive down hole heating tool
- [00173] US8087460 Granular electrical connections for in situ formation heating
- [00174] US8128786 RF heating to reduce the use of supplemental water added in the recovery of unconventional oil
- [00175] US8133384 US8337769 Carbon strand radio frequency heating susceptor
- [00176] US8168570 Method of manufacture and the use of a functional proppant for determination of subterranean fracture geometries
- [00177] US8333245 US8376052 Accelerated production of gas from a subterranean zone
- [00178] US8616273 Effective solvent extraction system incorporating electromagnetic heating
- [00179] US8646527 US8783347 Radio frequency enhanced steam assisted gravity drainage method for recovery of hydrocarbons
- [00180] US8674274 Apparatus and method for heating material by adjustable mode RF heating antenna array

- [00181]** US8691731 Heat generation process for treating oilfield deposits
- [00182]** US8729440 Applicator and method for RF heating of material
- [00183]** US8772683 Apparatus and method for heating of hydrocarbon deposits by RF driven coaxial sleeve
- [00184]** US8807220 Simultaneous conversion and recovery of bitumen using RF
- [00185]** US8936090 Inline RF heating for SAGD operations
- [00186]** US8960286 Heavy oil recovery using SF6 and RF heating
- [00187]** US20130220616 In situ heat generation

CLAIMS

1. A method for steam assisted gravity drainage (SAGD) production of hydrocarbons, the method comprising:

a) providing a plurality of horizontal production wells at a first depth at or near a bottom of a hydrocarbon play;

b) providing a plurality of horizontal injection wells, each one of the plurality of horizontal injection wells being laterally spaced at a distance D from an adjacent one of the plurality of horizontal production wells, wherein said distance D is at least 50 meters;

c) providing a plurality of lateral wells originating from at least some of said plurality of horizontal production wells, wherein said plurality of lateral wells cover at least 90% of said distance D and are open-hole laterals:

d) preheating a reservoir by injecting steam into all said wells to establish fluid communication between said plurality of horizontal injection wells and said plurality of horizontal production wells;

e) preheating said plurality of lateral wells using electromagnetic heating, resistive heating, or chemical heating; and

f) continuing steam injection in said plurality of horizontal injection wells only, and simultaneously producing mobilized heavy oil from said plurality of horizontal production wells.

2. A method for steam assisted gravity drainage (SAGD) production of hydrocarbons, the method comprising:

a) providing a plurality of horizontal production wells at a first depth at or near a bottom of a hydrocarbon play;

b) providing a plurality of horizontal injection wells, each one of the plurality of horizontal injection wells being laterally spaced at a distance D from an adjacent one of the plurality of horizontal production wells, wherein said distance D is at least 50 meters;

c) providing a plurality of lateral wells originating from at least some of said plurality of horizontal injection wells, wherein said plurality of lateral wells cover at least 90% of said distance D and are open-hole laterals:

d) preheating a reservoir by injecting steam into all said wells to establish fluid communication between said plurality of horizontal injection wells and said plurality of horizontal production wells;

e) preheating said plurality of lateral wells using electromagnetic heating, resistive heating, or chemical heating; and

f) continuing steam injection in said plurality of horizontal injection wells only, and simultaneously producing mobilized heavy oil from said plurality of horizontal production wells.

3. A method for steam assisted gravity drainage (SAGD) production of hydrocarbons, the method comprising:

a) providing a plurality of horizontal production wells at a first depth at or near a bottom of a hydrocarbon play;

b) providing a plurality of horizontal injection wells, each one of the plurality of horizontal injection wells laterally being spaced at a distance D from an adjacent one of the plurality of horizontal production wells, wherein said distance D is at least 50 meters;

c) providing a plurality of lateral wells originating from at least some of said plurality of horizontal production wells and said plurality of horizontal injection wells, wherein said plurality of lateral wells cover at least 90% of said distance D and are open-hole laterals:

d) preheating a reservoir by injecting steam into all said wells to establish fluid communication between said plurality of horizontal injection wells and said plurality of horizontal production wells;

e) preheating said plurality of lateral wells using electromagnetic heating, resistive heating, or chemical heating; and

f) continuing steam injection in said plurality of horizontal injection wells only, and simultaneously producing mobilized heavy oil from said plurality of horizontal production wells.

4. The method according to claim 1 or 3, wherein said plurality of lateral wells originate from every one of the plurality of horizontal production wells or every other one of the plurality of horizontal production wells and cover at least 95% of said distance D .

5. The method according to any one of claims 1 to 3, wherein said plurality of lateral wells are arranged in an alternating pattern.

6. The method according to any one of claims 1 to 3, wherein each one of the plurality of horizontal injection wells is about at said first depth.
7. The method according to any one of claims 1 to 3, wherein each one of the plurality of horizontal injection wells is at a lesser depth than said first depth.
8. The method according to any one of claims 1 to 3, wherein said distance D is at least 150 meters.
9. The method according to any one of claims 1 to 3, wherein said distance D is at least 100 meters.
10. A method for production of hydrocarbons, the method comprising:
 - a) providing a plurality of wellpairs in a heavy oil reservoir, each said wellpair including a horizontal production well at a bottom of a heavy oil payzone and a horizontal injection well above said horizontal production well thereof;
 - b) providing a standalone horizontal production well flanking each said wellpair, said standalone horizontal production well being at or near said bottom of said heavy oil payzone and at a lateral distance D from a nearest said wellpair, wherein said distance D is at least 50 meters;
 - c) providing a plurality of lateral wells originating from one or both of adjacent said horizontal production wells such that said plurality of lateral wells extend over at least 90% of said distance D and are open hole lateral wells;
 - d) preheating said plurality of wellpairs by injecting steam into all said wells until fluid communication is established between said plurality of wellpairs and simultaneously preheating said plurality of lateral wells using electromagnetic (EM) heating, resistive heating or chemical heating; and
 - e) continuing steam injection only in said horizontal injection wells after said preheating step d, and simultaneously producing mobilized heavy oil from said horizontal production wells.
11. The method according to claim 10, wherein said distance D is at least 100 meters.

12. The method according to claim 10, wherein said distance D is at least 150 meters.
13. The method according to claim 10, wherein said plurality of lateral wells extend over at least 95% of said distance D between adjacent said wells.
14. The method according to claim 10, wherein said standalone horizontal production well is completed with passive inflow control devices.
15. The method according to claim 10, wherein said EM heating uses a downhole antenna to heat susceptors in said plurality of lateral wells, and wherein an EM wavelength activates and heats said susceptors.
16. The method according to claim 10, wherein said EM heating uses a downhole antenna and a radio frequency (RF) wavelength to heat susceptors in said plurality of lateral wells.
17. The method according to claim 10, wherein said resistive heating uses electric current and a conductive material in said plurality of lateral wells, with said electric current travelling through and heating said conductive material.
18. The method according to claim 10, wherein said chemical heating uses a chemical pellet that exothermically reacts with water and wherein condensed steam is used to activate said chemical pellet.

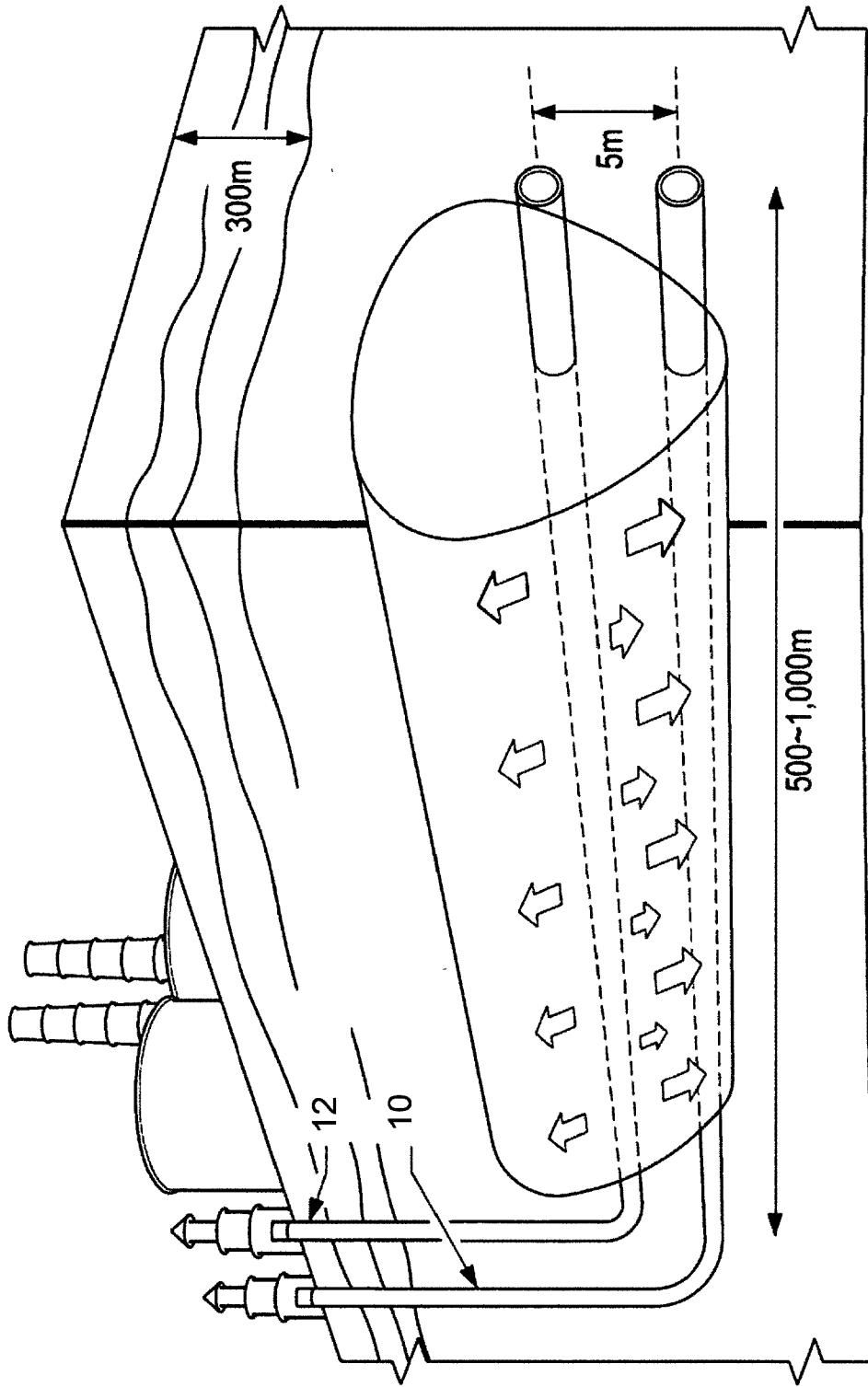

FIG. 1
(PRIOR ART)

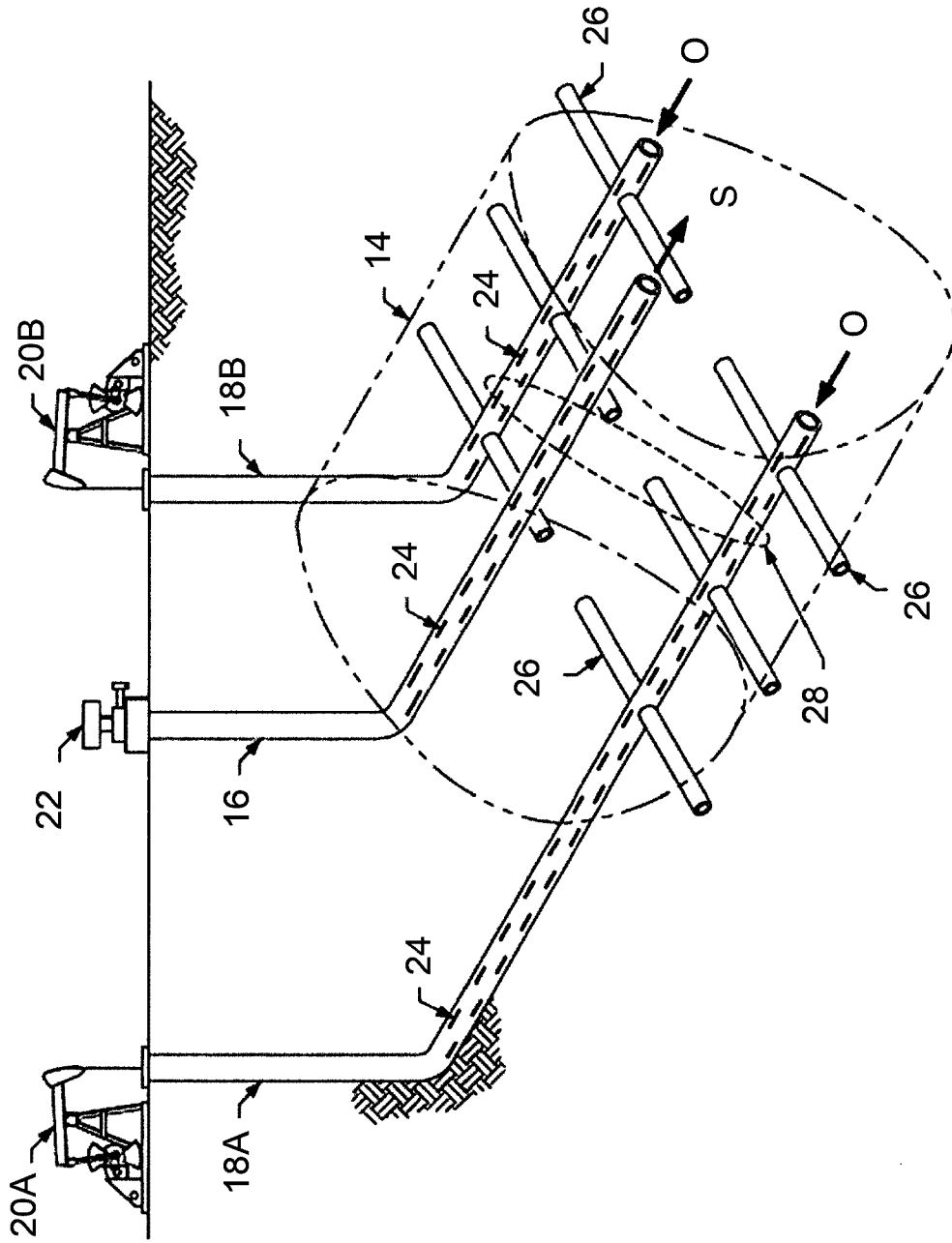

FIG. 2

