

Sept. 13, 1960

M. M. JONES

2,952,441

COOLING CONSTRUCTION FOR GAS TURBINE BLADES

Filed Dec. 10, 1956

2 Sheets-Sheet 1

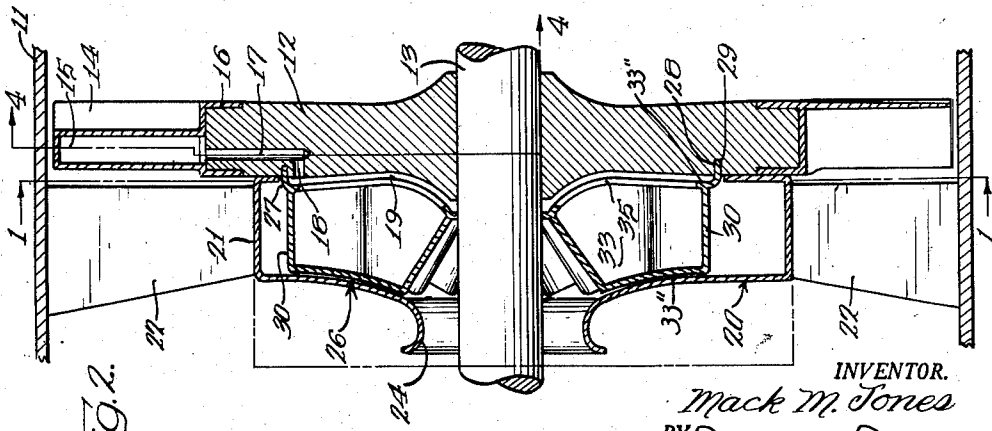
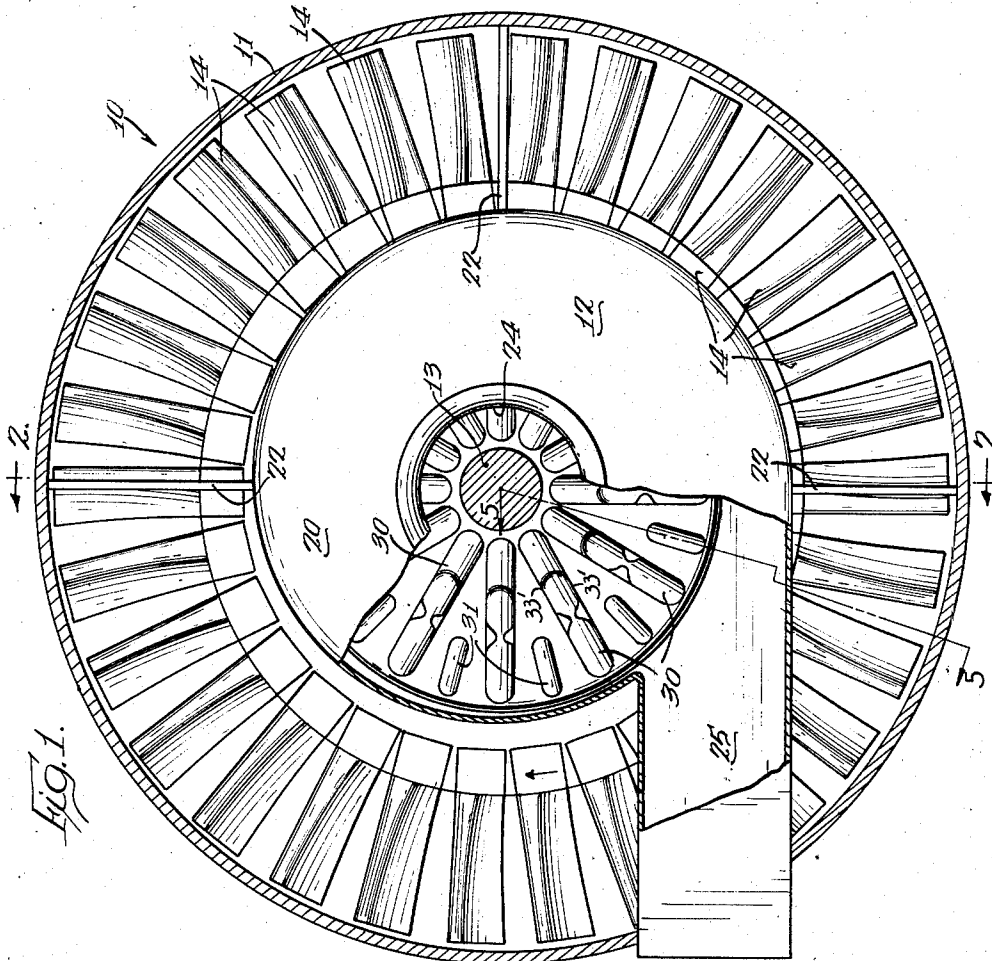

FIG. 2.

INVENTOR.
Mack M. Jones
BY Paul O. Rippe
Atty.

1

2,952,441

COOLING CONSTRUCTION FOR GAS TURBINE
BLADES

Mack M. Jones, Western Springs, Ill., assignor to International Harvester Company, a corporation of New Jersey

Filed Dec. 10, 1956, Ser. No. 627,269

1 Claim. (Cl. 253—39.15)

This invention relates to gas turbines and more specifically it relates to an improved cooling construction for cooling the blades of a gas turbine rotor.

It is a well known fact that one of the paramount problems in gas turbines is to provide turbine rotor blades which will satisfactorily withstand the high temperatures to which the blades are subjected by reason of the hot gases flowing through the blades to drive the rotor. In order to secure maximum efficiency of the turbine, high temperature gases under high pressure are directed to the rotor for driving the same. Various alloys have been tried with some success but in general it has been found that the turbine blades deteriorate rapidly under the extreme temperatures to which they are subjected. Accordingly it is a prime object of this invention to provide an improved cooling arrangement or construction for cooling the turbine blades of a turbine rotor during operation in order to reduce maintenance and increase the life of the turbine blades.

A still further object is to provide an improved cooling construction for gas turbine blades, the said construction including a cooling fan adapted to condense vapor into liquid, said liquid being directed to the turbine blades for cooling the same.

A still further object is to provide an improved gas turbine rotor having a plurality of hollow turbine blades adapted to receive coolant from a rotating cooling fan for cooling the said blades.

A still further object is to provide an improved cooling construction for gas turbine blades wherein liquid within the blades is vaporized, directed to a condensing means, the resultant condensed liquid again being directed by centrifugal force outwardly to the turbine blades for cooling the same.

A still further object is to provide an improved cooling construction for gas turbine blades, the rotor having connected thereto a cooling fan having hollow fan blades adapted to receive vapor from hollow turbine blades, the said vapor being condensed in the hollow fan blades and the resultant liquid being directed outwardly to the turbine blades for cooling the same.

These and further objects will become more readily apparent from a reading of the specification when examined in connection with the accompanying sheets of drawings.

In the drawings:

Figure 1 is a cross-sectional view taken generally along the line 1—1 of Figure 2 showing a gas turbine rotor and a fan housing with portions of the housing broken away to show a fan blade structure;

Figure 2 is a cross-sectional view through a turbine rotor and fan taken substantially along the line 2—2 of Figure 1;

Figure 3 is a fragmentary view generally similar to Figure 1, showing a turbine rotor including a fan housing and a plurality of fan blades, with portions of the fan blades broken away to show the interior construction thereof;

2

Figure 4 is a cross-sectional view through a turbine rotor taken generally along the line 4—4 of Figure 2;

Figure 5 is a fragmentary view of portions of a turbine rotor and fan, the said view being taken substantially along the line 5—5 of Figure 1; and

Figure 6 is a detail of a turbine blade in plan view.

Referring now particularly to Figures 1, 2 and 3 a gas turbine motor is generally designated by the reference character 10. The turbine motor 10 comprises a housing 11 within which a turbine rotor 12 is positioned for rotation. The turbine rotor 12 is suitably supported on a shaft 13 for rotating the same. A plurality of turbine blades 14 are circumferentially positioned around the outer periphery of the rotor 12. The turbine blades 14 are of hollow construction, each including a chamber 15. As indicated at 16 each of the blades 14 is suitably imbedded within the rotor 12. The rotor 12 also includes a plurality of bores 17, one of which is in communication with each chamber 15. Each bore 17 includes a passage 18 which opens outwardly along one side of the rotor 12. Each bore 17, thus is in communication with a chamber 15 and is also in communication with a chamber 19 disposed on one side of the rotor 12.

A fan casing 20 comprises a cylindrical metal body 21 suitably supported on the outer casing 11 by means of a plurality of spacers or supports 22. The fan casing 20 is provided with an inlet opening 24 and an exhaust or outlet duct 25. A fan 26 is disposed for rotation within the fan casing 20. The fan 26 comprises an annular plate 27 having a peripheral flange 28 which is suitably imbedded or fastened within the turbine rotor 12. The fan 26 comprises a plurality of relatively large hollow blades 30 and a plurality of relatively small hollow blades 31 suitably circumferentially spaced as particularly shown in Figure 1. The hollow blades 30 are suitably crimped as indicated at 32 in Figure 3, to provide individual chambers 33. The chambers 33 are formed by laterally spaced substantially parallel side walls 33' and end walls 33''. The small hollow blades 31 are also provided with chambers 34. The chambers 34 are formed by laterally spaced parallel side walls 34' and end walls 34''. As best indicated in Figure 2 the chambers 33 are in communication with the chamber 19 by means of openings 35 provided in the end walls 33'' nearest the rotor 12. As particularly shown in Figure 5 the chambers 34 are in communication with the chamber 19 by means of openings 36 provided in the end walls 34'' nearest the rotor 12.

The mechanism which provides for rotation of the turbine rotor may be conventional and is not shown. It may consist primarily of combustors which are adapted to direct hot gases under pressure through a nozzle ring which directs the hot gases into engagement with the turbine blades for providing rotation of the rotor 12. Such a nozzle ring is usually positioned immediately adjacent the rotor 12 with the nozzle blades in coaxial relation with respect to the turbine blades of the rotor.

In the operation the chambers 33 and 34 are filled with a suitable liquid. During high speeds of rotation the liquid is centrifugally directed outwardly from the chambers 33 and 34 through the chamber 19 and into the bore 17 whereupon the cooling liquid is delivered to the chambers 15 of the blades 14 for suitably cooling the said blades. Due to the extreme high temperatures of the gases from the gas turbine which engage the blades 14 and the liquid within the chamber 15 is vaporized and is forced inwardly back through the bores 17 and into the chambers 33 and 34 of the fan blades 30 and 31.

The fan 26 sucks air through the inlet opening 24 and discharges the same through the exhaust outlet 25. During this flow of air the blades 30 and 31 are cooled and the vapor within the chambers 33 and 34 is cooled

and condensed and returned to the blades 14 for cooling the same. The centrifugal action of the rotor causes the liquid to be forced outwardly to the chambers 15 of the blades 14 where the blades 14 are cooled. The liquid in the chambers 15 is then heated by the hot gases of the motor whereupon vapor is formed. The vapor being lighter than the liquid is then displaced by the liquid and travels inwardly to the chambers 33 and 34 whereupon the cycle is repeated. During operation of the gas turbine the cycle is continuously repeated and thus the turbine blades are constantly being cooled. Thus the temperatures at which the rotor can operate may be greatly increased and thus greater efficiency of the gas turbine results. With the effective cooling action thus afforded a much longer life of the blades results and less maintenance is required. It is of course contemplated that various cooling liquids may be utilized with equally good results.

Thus the objects of the invention have been fully achieved. It must be realized that changes and modifications in the structure may be made without departing from the spirit of the invention as disclosed or the scope thereof as defined in the appended claim.

What is claimed is:

A gas driven turbine comprising a turbine rotor, a plurality of turbine blades circumferentially disposed about the outer peripheral surface of said rotor, each of said turbine blades having a hollow portion, said rotor having a plurality of radially extending bores communicating with said hollow portions, said rotor also including a plurality of passages opening outwardly on a first side of said rotor, said passages communicating with said bores, a fan housing stationarily positioned ad-

acent said first side of said rotor, said fan housing including an air inlet and an air outlet, a fan connected to said rotor for rotation within said housing, a plurality of fan blades on said fan, each fan blade having substantially parallel laterally spaced side walls and axially spaced end walls, said walls providing a chamber in each fan blade, said end walls positioned nearest said first side of said rotor having openings communicating with said chambers of said fan blades, said fan blades and said chambers being positioned radially inwardly with respect to said hollow portions of said turbine blades, said openings of said fan blades communicating with the passages and said bores, a heat transfer liquid in said chambers of said fan blades, the hollow portions of said turbine blades being adapted to receive said heat transfer liquid by centrifugal force during rotation, said liquid being vaporized by heat from gas directed against the turbine blades to drive the same, the vapor traveling inwardly through said bores and passages into said chambers of said fan blades, being condensed and again being directed to said hollow portions of said turbine blades to cool the same.

References Cited in the file of this patent

UNITED STATES PATENTS

2,565,594	Constant	Aug. 28, 1951
2,737,366	Ledinegg	Mar. 6, 1956
2,782,000	Ledinegg	Feb. 19, 1957
2,848,190	Barr	Aug. 19, 1958

FOREIGN PATENTS

478,970	France	Nov. 2, 1915
---------	--------	--------------