

J. W. BLOWER.
RAILWAY FASTENING DEVICE.
APPLICATION FILED OCT. 1, 1910.

999,742.

Patented Aug. 8, 1911.

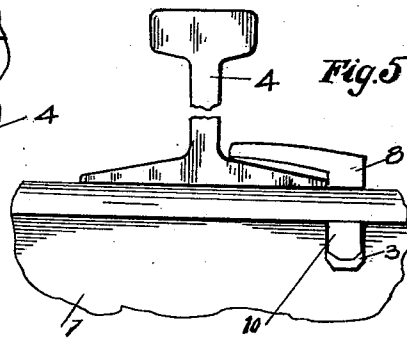
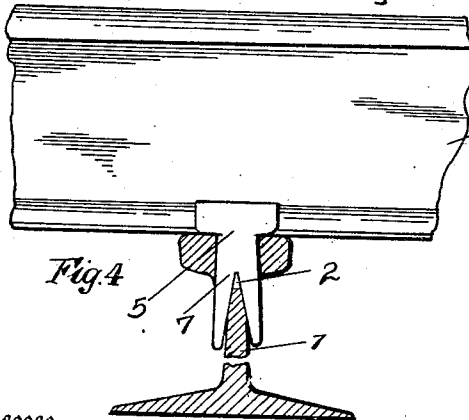
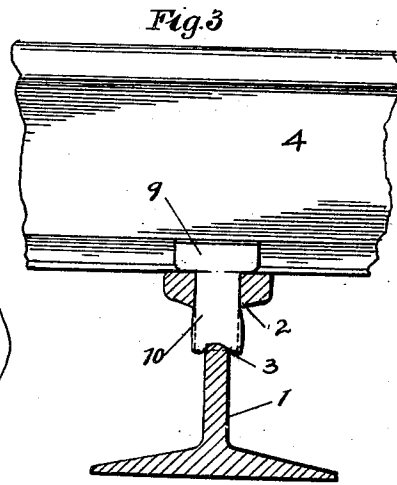
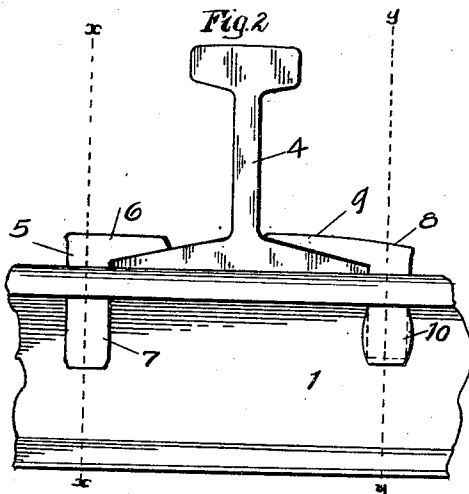
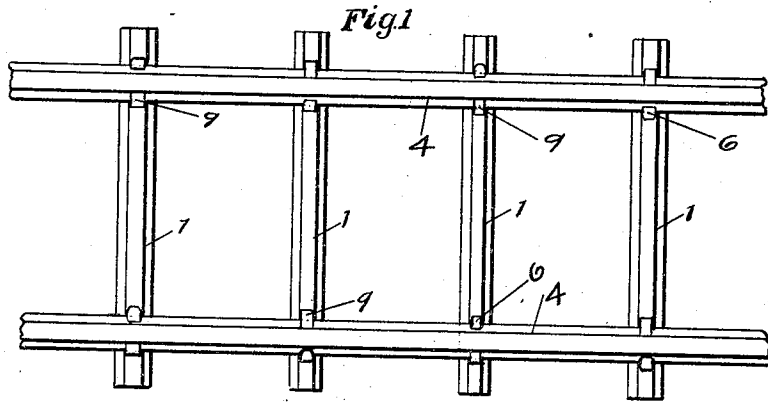

Witnesses
Dennis Dalton
A. L. Phelps

Inventor
Joseph W. Blower

By C. C. Shepherd
Attorney

UNITED STATES PATENT OFFICE.

JOSEPH W. BLOWER, OF COLUMBUS, OHIO.

RAILWAY FASTENING DEVICE.

999,742.

Specification of Letters Patent. Patented Aug. 8, 1911.

Application filed October 1, 1910. Serial No. 584,893.

To all whom it may concern:

Be it known that I, JOSEPH W. BLOWER, a citizen of the United States, residing at Columbus, in the county of Franklin and State of Ohio, have invented certain new and useful Improvements in Railway Fastening Devices, of which the following is a specification.

The present invention relates to certain novel and useful improvements in railway fastening devices, and has particular application to devices of the character described adapted especially for fastening the rails to metallic cross ties.

In carrying out my invention, it is my purpose to provide fastening means, the shanks of which may penetrate the ball or top of the tie, the latter being provided with a suitable opening therethrough, through which the shanks pass.

Still a further object of my invention is to provide a fastening device embracing a spike of soft metal such as steel, adapted when driven into the rail, which is of harder metal, to spread or lock itself therein, so that a firm, rigid fastening is provided, the upper portion or head of the spike at the same time being driven into contact with the base of the rail.

Still a further object of my invention is to provide a fastening device comprising a spike of hard metal provided with a split shank, which is adapted to embrace one side of the base of the rail, while the soft metal spike is driven at the opposite side of the rail.

It is also my purpose to provide a fastening device which will securely and rigidly hold the rail in position, which will embody the desired features of economy of cost of production and use.

With the above recited objects and others of a similar nature in view, my invention consists in the construction, combination and arrangement of parts set forth in and falling within scope of the appended claims.

In the accompanying drawings—Figure 1 is a plan view of a section of railway track, showing my improved fastening devices used in connection therewith, Fig. 2 is an end view of the rail and showing the manner of securing the same to the ties, the spikes being shown in their driven position, Fig. 3 is a view taken on the line $y-y$ of Fig. 2, Fig. 4 is a view taken on line $x-x$ of Fig. 2, and, Fig. 5 is an end view of the rail show-

ing the soft metal spike in position ready to be driven.

Referring now to the accompanying drawings in detail, the numeral 1 indicates a cross tie preferably formed of metal, said tie having vertical openings 2 formed in the top thereof, which merge or communicate with a horizontal or transverse opening 3 in the web of the tie.

The track rails are shown at 4 and may be of any ordinary or well known construction. In order to secure the rails 4 to the ties 1, I provide a spike 5 the head 6 of which is adapted to engage the base of the rail, while the shank 7 which is bifurcated, extends through a vertical opening 2 in the tie and spreads at the opening in the web with the bifurcated members lying at opposite sides of the web. I also provide a second form of spike, shown at 8 which spike is preferably formed of soft steel, while, as heretofore stated, the tie is made of hardened steel. The head 9 of the spike 8 is made of the same material as the shank, that is, of soft steel and is preferably relatively elongated, so that when driven into position, as is shown in Fig. 2, the end of said head will abut against the web 4. The shank 10 of the soft metal spike, is formed solid or in one piece, and is adapted to project through the vertical and transverse openings in the tie. In Fig. 5, I have shown this soft spike in position to be driven, while in Fig. 2, said spike is shown as in driven position and it will be noted that as the end of the soft shank is brought into contact and driven against the hard metal of the web, at the base of the transverse opening, the soft shank will spread as is shown in Figs. 2 and 3, and by thus spreading or bulging, locks itself and thereby prevents accidental withdrawal of the spike. It will further be noted that when driven home, the head of the spike will contact with the base of the rail and flatten against the same, while the shank of the spike itself is securely wedged in the opening. In Fig. 1 wherein I have shown the track rail section, it will be noted that the split spikes and the soft metal solid spikes, are arranged alternately, that is, instead of having all the split spikes at the outside of the rail, or the soft ones so arranged, I alternate the positions of the spikes at the different ties. I wish it to be understood, however, that I do not limit myself to this arrangement, as is shown in

Fig. 1, as the spikes may be arranged in any suitable or desired manner.

It will be noted that I have provided an exceedingly simple form of fastening device, yet one which will securely hold the rail in position and further that the metal of the soft spike spreading in the opening and against the harder metal of the web, forms a secure locking device, cooperating with the hard split shank spikes at the opposite side of the base of the rail.

What I claim, is—

1. The combination with the track rails and metallic ties having openings therein, of means for fastening the rails to the ties, said means including a spike formed of separate material than the tie, said spike having a solid shank adapted when the spike is driven through the opening in the tie to contact with the web of the latter and spread and lock therein.

2. The combination with the track rails and the metallic cross ties having spike openings therein, of means for fastening the rails of the ties comprising a hard metal spike adapted to be driven through one of the openings in the tie and into contact with the base of the rail, and a second spike at the opposite side of the rail, said second spike being formed of soft steel and having

a solid shank adapted to spread when forced into contact with the web of the tie and thereby lock in the tie.

3. The combination with the track rails and the metallic cross ties having openings therein, of means for fastening the rails to the ties, said means comprising a spike of relatively hard metal adapted to be driven through one of the openings in the ties and into contact with the base of the rail, and a second spike of soft steel provided with an elongated head and a solid shank, the shank of the spike when driven spreading in the opening in the tie, while the head is forced into contact with the base of the rail and up against the web of the latter.

4. The combination with the track rails and the metallic cross ties, of fastening means therefor including a spike of soft steel having an elongated head and a solid shank, said shank spreading and locking when driven through an opening in the tie and into contact with the web of the tie.

In testimony whereof I affix my signature in presence of two witnesses.

JOSEPH W. BLOWER.

Witnesses:

INGLE A. MORRIS,
A. L. PHELPS.