

Nov. 17, 1953

V. KELSEY

2,659,404

COMBINATION BEACH TOWEL AND BEACH BAG

Filed Feb. 8, 1952

2 Sheets-Sheet 1

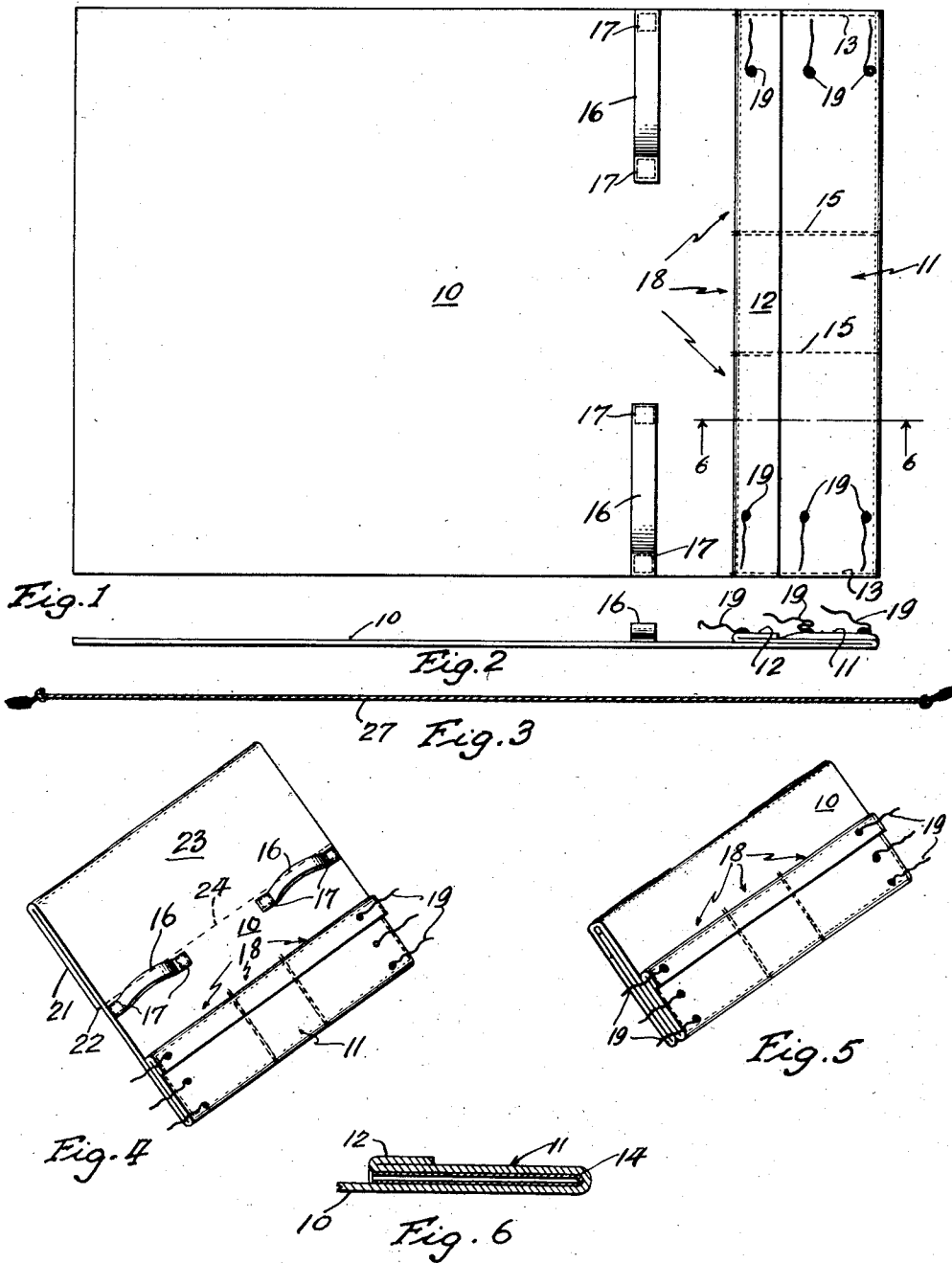

Inventor:
Virginia Kelsey,
by Andros and Smith
Her Attorneys.

Nov. 17, 1953

V. KELSEY

2,659,404

COMBINATION BEACH TOWEL AND BEACH BAG

Filed Feb. 8, 1952

2 Sheets-Sheet 2

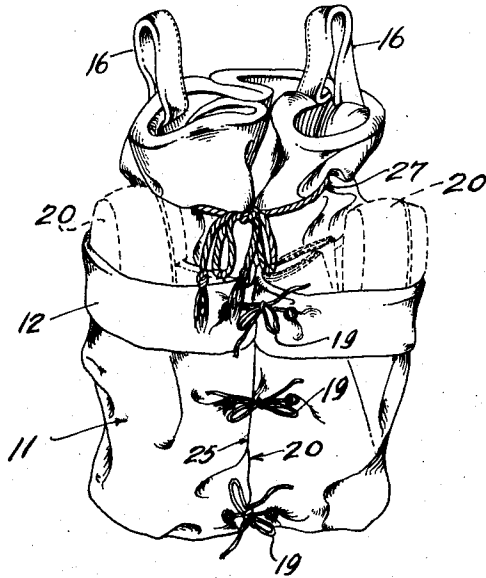

Fig. 8

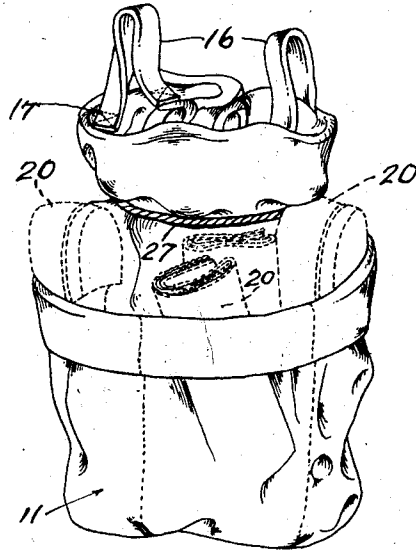

Fig. 9

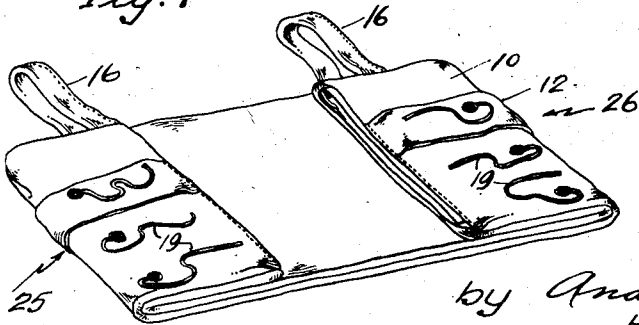

Fig. 7

Inventor:
Virginia Kelsey,
by Andros and Smith
Her Attorneys.

UNITED STATES PATENT OFFICE

2,659,404

COMBINATION BEACH TOWEL AND BEACH BAG

Virginia Kelsey, Delmar, N. Y.

Application February 8, 1952, Serial No. 270,546

1 Claim. (Cl. 150—1)

1

This invention relates to an improved type of beach bag, having particular reference to a combination beach towel and beach robe arrangement adapted, when properly folded and secured in position, to provide a beach bag for carrying articles to and from beaches, and the provision of such an article is a principal object of the invention.

Generally, it is an object of the invention to provide such an article which is sturdy, yet simple and durable in construction, economic to manufacture, colorful and attractive in appearance, and well suited to the purposes for which it is intended.

More specifically, it is an object of the invention to provide a beach bag formed from an elongated rectangular sheet of suitable material folded along a plurality of lines extended transversely of the sheet and having the lateral edges of the folded sheet disposed in juxtaposed relation, with means for detachably holding the lateral edges of the sheet in proximity to each other when so folded, means forming a carrying handle secured to the folded sheet in a zone adjacent that portion thereof forming the top of the bag, and means secured to the folded sheet and laterally surrounding and cooperating therewith to form a pocket of substantial depth around the lower portion of the folded sheet.

Yet more specifically, it is an object of the invention to provide a combined beach bag and towel made of an elongated rectangular sheet of terry cloth, or the like, having one end thereof overfolded and secured in such position by stitching at the lateral marginal edges thereof to form a pocket extending transversely of the sheet at such end, with aligned carrying handles secured to the sheet adjacent the lateral marginal edges thereof and extending transversely therefrom substantially parallel to the ends of the sheet, and in spaced parallel disposed relation to the top of the pocket, and tie strings secured to the pocket adjacent the ends thereof, in order that the sheet, when folded along transversely extending parallel disposed lines, may be transversely folded and secured in folded position by the tie strings to form a beach bag structure with the carrying handles at the top thereof.

Other specific objects of the invention are the provision of such an article in which the pocket is divided into a plurality of smaller pockets by lines of stitching extending longitudinally of the sheet, the pockets preferably being lined with water-proof material; in which the pocket forming means is an overfolded portion of the sheet;

2

in which the bag is provided with a tie string surrounding the same in a zone intermediate the top of the pocket and the handle, or handles, and in which the means detachably securing the lateral edges of the folded sheet together comprises tie strings.

Other objects of the invention will in part be obvious and will in part appear hereinafter.

The invention accordingly comprises the features of construction, combination of elements, and arrangement of parts, which will be exemplified in the construction hereinafter described and the scope of the application of which will be indicated in the claim.

For a fuller understanding of the nature and objects of the invention reference should be had to the following detailed description taken in connection with the accompanying drawing, in which:

Fig. 1 is a plan view of the beach bag when opened up to provide a beach robe and towel;

Fig. 2 is a lateral edge view thereof;

Fig. 3 is a tie string, or rope, for securing the robe, or towel, when folded, in position;

Fig. 4 is an isometric view illustrating one manner of folding the robe, or towel to provide a bag;

Fig. 5 is another isometric view illustrating a further folding arrangement to provide such a bag;

Fig. 6 is a transverse sectional view, somewhat enlarged, of a fragmentary portion of the robe, or towel, in the pocket area illustrated in Fig. 1, taken along the lines 6—6, and looking in the direction of the arrows, illustrating the pocket lines with a suitable waterproof material;

Fig. 7 is another isometric view, somewhat enlarged, illustrating a further step of folding the article depicted in Figs. 4 and 5;

Fig. 8 is an elevational view of the same, with articles therein, finally folded, or rolled into position and secured together to provide such a bag; and

Fig. 9 is a rear elevational view of Fig. 8.

Referring more particularly to the drawings there is shown at 10 an elongated rectangular sheet of terry cloth, or the like, having one end portion 11 overfolded upon itself. Preferably, a marginal portion 12 of the free edge is backfolded upon the overfolded portion 11. The overfolded portions 11 and 12 are stitched, or otherwise secured, to the body of the sheet along opposite side edges as indicated at 13, 13 to provide a pocket for the reception of any suitable articles such as beach shoes, smaller towels, soap, combs or the like.

3

Preferably this pocket is lined with any suitable type of water-proof material as indicated at 14 in Fig. 6 of the drawing.

Also, the pocket may be subdivided into two or more pockets by medial lines of stitching 15, 15, 5 passing through the overfolded and back-folded portions 11 and 12, in the same manner as provided by the stitching 13, 13.

One or more carrying handles 16, 16 may be secured to the sheet 10 by stitching 17, 17 adjacent the lateral marginal edges thereof and ending inwardly therefrom substantially parallel to the ends of the sheet, and in spaced parallel disposed relation to the top of the pocket, or pockets, generally indicated at 18.

Secured to the pocket, or pockets, inwardly adjacent opposite side edges of the sheet are a plurality of tie strings 19 to secure the sheet 10, when folded and suitably rolled into position, together after the pockets have been filled with articles, if desired, as will more fully appear hereinafter. Such articles are illustrated, for example, at 20 in dotted line position in Figs. 8 and 9.

When the beach robe or towel is ready for carrying purposes it may first be folded along a transverse line as shown in Fig. 4 so that the end 21 opposite the overfolded portion 11 is underfolded and the free edge 22 of the underfolded end 21 lies approximately adjacent the carrying handles 16 on the opposite side thereof. The overfolded portion 21 and the portion 23 adjacent thereto is then again folded along a transverse line as indicated by the dotted line 24 in the zone of attachment of the handles 16, 16. Both portions 21 and 23 then overlies the remaining body portion 10 and the pocket, or pockets 18. The so folded article is then placed with the pockets in a downward position and folded longitudinally as indicated generally at 25 and 26 in Fig. 7. Thereupon the edges provided by the folded over ends at 25 and 26 are brought into abutting relation so that the tie strings 19 along each marginal side portion may attractively be tied together to form bows as indicated in Fig. 8.

In order to render a further attractive appearance to the desired contour and configuration of the resulting rolled-up arrangement of the beach towel or robe to provide a beach bag embodied by the invention, a tie string or rope 27, as shown in the Fig. 3 is then tightly tied around the neck of the bag intermediate overfolded portion and the handles 16.

In order further to enhance the attractiveness of the beach bag, or towel, the same may be made in a variety of colors which will add to the eye appeal of the beach bag.

4

It will thus be seen that the objects hereinbefore set forth may readily be attained, and since certain changes may be made in the above article and different embodiments of the invention could be made without departing from the scope thereof, it is intended that all matter contained in the above description or shown in the accompanying drawing shall be interpreted as illustrative and not in a limited sense.

It is also to be understood that the following claim is intended to cover all of the generic and specific features of the invention which, as a matter of language, might be said to fall therebetween.

Having described my invention what I claim as new and desire to secure by Letters Patent is:

An article of manufacture of the character described, comprising an elongated, rectangular sheet of moisture absorbent cloth material for use as a combination beach robe, a towel and, when folded, rolled and secured into position, a beach bag, to provide which said sheet has one marginal end portion thereof overfolded transversely of its longitudinal axis with the adjacent overfolded edges thereof substantially flush with each other; rows of oppositely disposed stitches securing the flush edges together to provide a completely accessible outside pocket, overfolded upon itself along lines parallel to said stitches and rolled into substantially circular position with respect to the vertical axis of said bag; a row of stitches intermediate said first named rows to divide said pocket into compartments and to secure said first overfolded portion in position to a remaining inner portion of said sheet; said remaining inner portion of said sheet being folded upon itself transversely of its longitudinal axis and disposed within the outer confines of said pocket; opposite edges of said last named overfolded pocket being in abutting relation; means securing said abutting edges together; and means secured to said sheet to extend above said bag to carry the same.

VIRGINIA KELSEY.

References Cited in the file of this patent

UNITED STATES PATENTS

Number	Name	Date
398,530	Moore	Feb. 26, 1889
444,029	Vickery	Jan. 6, 1891
1,269,276	Harris	June 11, 1918
1,286,104	Reichmuth	Nov. 26, 1918
1,747,010	Keller	Feb. 11, 1930
2,507,842	Waddill	May 16, 1950