

(19) World Intellectual Property Organization
International Bureau



(43) International Publication Date
10 May 2001 (10.05.2001)

PCT

(10) International Publication Number
WO 01/33371 A1

- (51) International Patent Classification⁷: G06F 13/00, 17/30
 - (21) International Application Number: PCT/US00/41274
 - (22) International Filing Date: 18 October 2000 (18.10.2000)
 - (25) Filing Language: English
 - (26) Publication Language: English
 - (30) Priority Data: 09/435,142 5 November 1999 (05.11.1999) US
 - (71) Applicant: SURFMONKEY.COM, INC. [US/US]; 1901 S. Bascom Ave., 4th Floor, Campbell, CA 95008 (US).
 - (72) Inventors: CHUPIN, Fabrice; SurfMonkey.com, Inc., 1901 S. Bascom Ave., 4th Floor, Campbell, CA 95008 (US). SMITH, David; SurfMonkey.com, Inc., 1901 S. Bascom Ave., 4th Floor, Campbell, CA 95008 (US). JAROL, Scott; SurfMonkey.com, Inc., 1901 S. Bascom Ave., 4th Floor, Campbell, CA 95008 (US). REDKEY, David; SurfMonkey.com, Inc., 1901 S. Bascom Ave., 4th Floor, Campbell, CA 95008 (US).
 - (74) Agents: WININGER, Aaron et al.; Carr & Ferrell LLP, Suite 200, 2225 East Bayshore Road, Palo Alto, CA 94303 (US).
 - (81) Designated States (national): AE, AG, AL, AM, AT, AU, AZ, BA, BB, BG, BR, BY, BZ, CA, CH, CN, CR, CU, CZ, DE, DK, DM, DZ, EE, ES, FI, GB, GD, GE, GH, GM, HR, HU, ID, IL, IN, IS, JP, KE, KG, KP, KR, KZ, LC, LK, LR, LS, LT, LU, LV, MA, MD, MG, MK, MN, MW, MX, MZ, NO, NZ, PL, PT, RO, RU, SD, SE, SG, SI, SK, SL, TJ, TM, TR, TT, TZ, UA, UG, UZ, VN, YU, ZA, ZW.
 - (84) Designated States (regional): ARIPO patent (GH, GM, KE, LS, MW, MZ, SD, SL, SZ, TZ, UG, ZW), Eurasian patent (AM, AZ, BY, KG, KZ, MD, RU, TJ, TM), European patent (AT, BE, CH, CY, DE, DK, ES, FI, FR, GB, GR, IE, IT, LU, MC, NL, PT, SE), OAPI patent (BF, BJ, CF, CG, CI, CM, GA, GN, GW, ML, MR, NE, SN, TD, TG).
- Published:**
- With international search report.
 - Before the expiration of the time limit for amending the claims and to be republished in the event of receipt of amendments.

[Continued on next page]

(54) Title: SYSTEM AND METHOD OF FILTERING ADULT CONTENT ON THE INTERNET

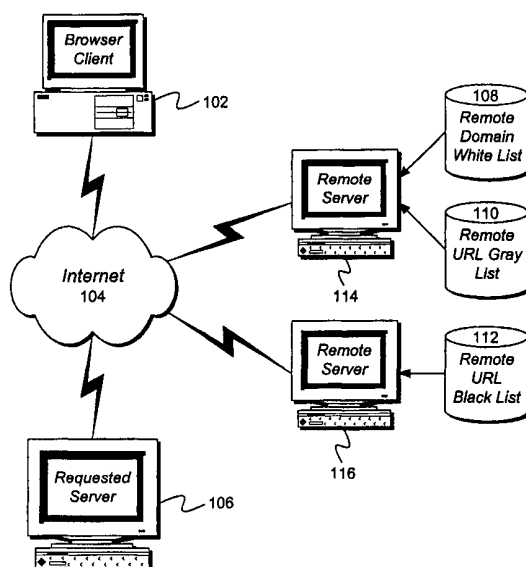

(57) Abstract: A filter for use interactively with an Internet web browser for filtering adult content (102). The filter utilizes a filter database to screen information requested for viewing within a web browser. The information is screened locally by a domain white list (108), an URL black list (112), and an URL white list. The information is also screened remotely from a domain white list (108), an URL gray list (110), and an URL black list (112). Furthermore, words within the requested web page are screened with a local word gray list and a local word black list (112) to add further filtering features prior to displaying the web page to the user. The amount of filtering is readily modified through local content access settings by a local supervisor and by the selection of the remote site(s) (114 and 116) contacted for additional content access control information.



WO 01/33371 A1



For two-letter codes and other abbreviations, refer to the "Guidance Notes on Codes and Abbreviations" appearing at the beginning of each regular issue of the PCT Gazette.

SYSTEM AND METHOD OF FILTERING ADULT CONTENT ON THE INTERNET

By Fabrice Chupin, David Smith, Scott Jarol, and David Redkey

5

BACKGROUND OF THE INVENTION

1. Field of the invention

10 The present invention relates generally to a web browser and methods thereof and more specifically to a web browser having embedded content filtering and methods thereof.

2. Description of the Prior Art

15 Information made available through the Internet in the form of Web Sites, Chat Rooms and Electronic Mail, is generally unregulated. Internet Directory Services and Search Engines such as Yahoo®, HotBot® and others can provide order to the subject matter of the vast amount of information available. However Directory Servers are generally limited to categorizing Web Sites based on Keywords supplied by the site's content provider. Actual content is generally not verified. Internet Search Engines typically provide results by matching the same Keywords to a specific user query to generate a list of matches for each specific query. Again, actual content of the matches is generally not checked. For some users, for example children, such unregulated access is undesirable. In addition, some young users have difficulty in navigating through the vast Internet resource and would benefit if assistance in accessing appropriate information could be made available.

25 Popular Internet Browsers such as the Netscape Navigator® and the Microsoft Internet Explorer® provide some of content screening. However, this screening is generally limited only to Web Sites and typically involves several levels of setup interaction on the part of a parent or guardian to become active. Typically, once active, the content screening is not user specific, thus where a parent might want to limit a child's access to some Internet content, the parent may not want all users limited in the same manner. Other solutions to content screening, for example stand alone solutions such as Surf Watch® or Net Nanny®, while also effective at limiting access to undesirable Web Sites, generally have the same limitations with regard to other sources of Internet content as the browsers. Another limitation of the content screening provided by currently available solutions is that it is typically focused only on sex,

violence and the like, and thus is directed primarily to protecting children. The need for content screening, however, can extend beyond this current focus. For example, in some corporate environments where Internet access is desirable, often it would be more desirable if that access could be readily managed beyond the level that current Browser controls make
5 available. In addition, it would be desirable if this content screening could be effected with little or no monitoring by corporate censors.

There is a need for Internet content regulation and/or screening that is not limited to only preventing access to undesirable Web Sites. This need for regulation extends to other sources of information available through the Internet such as Electronic Mail, Chat Rooms,
10 News Groups and the like. In addition, it would be advantageous for this Internet content regulation to be available through an integrated solution, thus simplifying control of the criteria used for the screening process. It would also be desirable if this integrated solution could be tailored to meet a variety of needs, from those of young children to those of teens, young adults and others. Thus, it would be desirable if such an integrated solution could provide interactive
15 assistance to help direct activities where appropriate within a friendly, engaging, graphical interface.

SUMMARY OF THE INVENTION

A filter for interactive use with an Internet web browser for filtering adult content is provided. The filter utilizes a filter database to screen information requested for viewing
5 within a web browser. The information is screened locally by a domain white list, an URL black list, and an URL white list. The information is also screened remotely from a domain white list, an URL gray list, and an URL black list. Furthermore, words within the requested web page are screened with a local word gray list and a local word black list to add further filtering features prior to displaying the web page to the user. The amount of filtering is
10 readily modified through local content access settings by a local supervisor and by the selection of the remote site(s) contacted for additional content access control information.

BRIEF DESCRIPTION OF THE DRAWINGS

The present invention may be better understood, and its numerous objects, features, and advantages made apparent to those skilled in the art by referencing the accompanying illustrations. For simplicity and ease of understanding, common numbering of elements is employed where an element is the same in different illustrations.

FIG. 1 is a schematic diagram illustrating a browser client requesting a web page over the internet from a requested server, wherein the browser client also accesses remote servers to help filter adult content from the requested web page, in accordance with the present invention;

FIG. 2 is a block diagram of the browser client's computer shown in FIG. 1, in accordance with the present invention;

FIG. 3 is a block diagram of one embodiment of the non-volatile memory module located within the browser client's computer of FIG. 2;

FIG. 4 is a schematic block diagram illustrating the browser and local filter database shown in the non-volatile memory module of FIG. 3 and how the web browser connects with a remote filter database;

FIG. 5 is a flowchart of a method for a supervisor to add or remove user limitations for web browsing, according to the invention;

FIG. 6 is a flowchart depicting the manner in which screening and/or filtering aspects are applied within an embodiment in accordance with the present invention;

FIG. 7 is a flowchart depicting the method of filtering continued from Process A in FIG. 6;

FIG. 8 is a flowchart depicting the method of filtering continued from Process B in FIG. 6, in accordance with the present invention;

FIG. 9 is a flowchart depicting the method of filtering continued from Step A in FIG. 8;

FIG. 10 is a flowchart depicting the method of filtering continued from Step B in FIG. 8; and

FIG. 11 is a flowchart depicting the method of filtering continued from Consolidated Concurrent Processes A and B in FIG. 7 and FIG. 8, according to the present invention.

DETAILED DESCRIPTION OF THE INVENTION

The following is a detailed description of illustrative embodiments of the present invention. As these embodiments of the present invention are described with reference to the
5 aforementioned illustrations, various modifications or adaptations of the methods and or
specific structures described may become apparent to those skilled in the art. All such
modifications, adaptations, or variations that rely upon the teachings of the present invention,
and through which these teachings have advanced the art, are considered to be within the spirit
and scope of the present invention. Hence, these descriptions and drawings should not be
10 considered in a limiting sense, as it is understood that the present invention is in no way limited
to only the embodiments illustrated. For example, while FIGs. 1-11 illustrate an embodiment
in accordance with the present invention that is directed to filtering adult content on the
internet within a web browser, other embodiments can be directed to adult users. For example,
in some embodiments of the present invention, content screening and or regulation is directed
15 in a topical manner, such as all content related to a specific interest and related topics.

Referring now to FIG. 1, a schematic diagram illustrating a browser client 102
requesting a web page over the internet 104 from a requested server 106, wherein the browser
client 102 also accesses remote filter databases 108, 110, 112 at remote servers 114, 116 to
help filter adult content from the requested web page.

20 FIG. 2 is a block diagram of the browser client's computer 102 shown in FIG. 1. The
browser client 102 includes a CPU 202, a ROM 204, a RAM 206, an Internet interface 208, a
non-volatile memory 210, an input device 212, and a display 214. The browser client 102
provides for a computer set-up that can run specific software to browse the Internet.

Referring now to FIG. 3, a block diagram of one embodiment of the non-volatile
25 memory module 210 located within the browser client computer 102 of FIG. 2 is shown. The
non-volatile memory 206 includes an installer module 302, a web browser 304, an email
module 306, a chat module 308, an animation module 310, and a local filter database 312. The
installer module 302 is used to install specific web browsing software that allows the web
browser to filter material from requested web pages. The web browser 304 is an Internet web
30 browser programmed to filter content from requested web pages. The email module 306, chat
module 308, and animation module 310 are additional features that can be incorporated with
the web browser 304 in order to provide enhanced functionality for a user using the web
browser 304. It is possible to incorporate some of the new filtering techniques described

herein to email and chat features incorporated with the web browser 304. The local filter database 312 contains information that helps filter content from web pages and is discussed in conjunction with FIG. 4.

FIG. 4 is a schematic block diagram illustrating the web browser 304 and local filter database 312 shown in the non-volatile memory module 210 of FIG. 3, and how the web browser 304 connects with a remote filter database 400. The web browser 304 includes an Internet browsing engine 402 connected to a filtering engine 404. The Internet browsing engine 402 passes requests to read a web page through the filtering engine 404. The filtering engine 404 analyzes the contents of the web page by accessing and utilizing information contained in the local filter database 312 and the remote filter database 400. In this instance, the web browser 304 is programmed to work interactively with the filtering engine 404. An example of a web browser programmed to work interactively with a filtering engine is a SurfMonkey™ browser made available by SurfMonkey.com, Inc. of Campbell, California. The filtering engine 404 can also be programmed as an add-on to work interactively with other existing web browsers such as Netscape Navigator® and Microsoft Internet Explorer®.

The remote filter database 400 includes remotely accessed databases (as shown in FIG. 1), namely a domain white list 108, an URL gray list 110, and an URL black list 112. The remote filter database 400 can include filters from various independent sources such as Surf Watch®. This provides flexibility in incorporating established filter databases and to help provide quality filters for use with the filtering engine 404.

The domain white list 108 includes a database of acceptable domain names for viewing by the web browser 304. The URL gray list 110 includes a database of web pages that contain a small number of questionable material that may need to be filtered by the filtering engine 404 before being displayed in the web browser 304. The URL black list 112 includes a database of web pages that would be fully blocked by the web browser 304.

Within the local filter database 312 located on the browser client's computer 102, the local domain white list 406 includes a database of acceptable domain names. The local domain white list 406 is a list of acceptable domain names for viewing as defined by the remote domain white list 108.

The local URL black list 408 includes a database of unacceptable web pages that were defined by a supervisory user to be unacceptable or were previously found to be unacceptable by the filtering engine 404.

The local URL white list 410 includes a database of acceptable web pages that were added by a supervisory user to be acceptable pages for viewing, or were previously found to be acceptable by the filtering engine 404 during the current web browsing session. The web pages in the local URL white list 410 that were found to be acceptable by the filtering engine 404 during the web browsing session are deleted after the web browsing session is over. The acceptable web pages in the URL white list 410 defined by a supervisory user remain in the database for use with future web browsing sessions.

The local word gray list 412 is a database of questionable words that may need to be filtered from the web page. Examples of gray list words would include words that may or may not be offensive depending on how they are used and in what context. The local word black list 414 is a database of words that are unacceptable and would need to be filtered or blocked accordingly.

Referring now to FIG. 5, a flowchart of a method for a supervisor to add or remove user limitations for web browsing is shown. At step 500 a supervisor begins to log into the web browser security controls. Step 502 determines if the person logging into the security controls feature is an authorized user, such as a parent. If the person logging in does not supply the correct password, then at step 504 access is denied to the supervisory security controls. If the correct password is supplied, then at step 506 the supervisor can add or remove specific URLs or web pages from the local domain white list 406, the local URL black list 408, and the local URL white list 410. The supervisor can also add or remove words from the local word gray list 412 and the local word black list 414. If at step 508, the supervisor has finished editing the local database lists, then at step 510 the supervisory controlling ends, otherwise, at step 506, the supervisor can continue to edit the local database lists.

Referring now to FIG. 6, a flowchart depicting the manner in which a web page is filtered is shown. At step 600 a user begins using the web browser with the filtering engine. At step 602, the user requests to view a specific web page. If at step 604 it is determined that the security setting for filtering web pages is off, then at step 606 the web page is displayed to the user and at step 608 the filtering process ends. If at step 604 the security setting for filtering web pages is on, then the filtering process continues at step 610 wherein a remote domain white list 108 is accessed over the Internet and is copied over to the local domain white list 406 that is resident on the user's computer. Next at step 612, separate processes 614, 616 begin and are shown in FIGS 7 and 8.

FIG. 7 is a flowchart depicting the method of filtering continued from process A 614 in FIG. 6. At step 700 the web page requested by the user is initiated to the server and at step 702 the web page is downloaded into a hidden browser window that prohibits the user from seeing the web page at this time. Then at step 704 process A is consolidated with process B and
5 continue on FIG. 11.

FIG. 8 is a flowchart depicting the method of filtering continued from process B 616 in FIG. 6. At step 800, it is determined if the requested web page is in the local domain white list 406. If at step 802 it is determined that the web page is on the local domain white list 406 then at step 704 process B is consolidated with process A and continues at FIG. 11. However, if the
10 web page is not on the local domain white list 406 then at step 804 it is determined whether the requested web page is in the local URL black list 408. If at step 806 the web page is found in the local URL black list 408, then at step 808 the web page is stopped from being downloaded and continues at step A in FIG. 9.

If the web page URL is not in the local URL black list 408, then at step 810 it is
15 determined if the web page is in the local URL white list 410. If at step 812 the web page URL is found in the local URL white list, then at step 704 process B is consolidated with process A and continues at FIG. 11. If at step 812 the web page is not found in the local URL white list, then at step 814 it is determined if the web page URL is in a remote URL gray list 110. If at step 816 the web page is found in the remote URL gray list 110 then at step 704 process B is
20 consolidated with process A and continues at FIG. 11. If the web page is found in the remote URL gray list 110, then a search for the web page is the remote URL black list 112 is bypassed. The remote URL gray list 110 can include potentially acceptable web pages that may have been placed on the remote URL black list 112. The web pages listed on the remote URL gray list 110 may only require filtering of some words, as is described in further detail in
25 conjunction with FIG. 11.

If the web page is not found in the remote URL gray list 110, then at step 820 it is determined if the web page URL is in the remote URL black list 112. If at step 822 the web page is not found in the remote URL black list 112 then at step 704 process B is consolidated with process A and continues at FIG. 11. However, if at step 822 the web page is found in the
30 remote URL black list, then at step 824 the web page is stopped from being downloaded and continues at step B in FIG. 10.

Referring now to FIG. 9, as referenced from step A 808 in FIG. 8, the web page filtering continues. At step 900 the web page is stopped from being downloaded, then at step

902 a page is shown to the user indicating that the selected web page is blocked from viewing since it was found in the local URL black list 408. Next at step 904, it is determined if the web page URL is in the remote URL black list 112. If the web page is not in the remote URL black list 112, then at step 908 the web page URL is removed from the local URL black list 408

5 since this web page is no longer black listed by the remote URL black list 112. Alternatively, if the page URL was specifically entered by a supervisor into the remote URL black list, then the web page URL would not be removed from the local URL black list. If at step 906 the web page is found in the remote URL black list, then at step 910 the filtering process ends.

Referring now to FIG. 10, a flowchart depicting the method of filtering continued from Step B in FIG. 8 is shown, wherein the requested web page URL was also found in the remote URL black list 112. At step 1000 the web page is stopped from being downloaded, then at step 1002 a page is shown to the user indicating that the selected web page is blocked from viewing since it was found in the remote URL black list 112. Next at step 1004 the web page URL is added to the local URL black list 410 residing on the user's computer. Then at step 1006 it is
10 determined if the web page URL is in the local URL white list 410. If the web page is found in the local URL white list 410, then at step 1010 the web page URL is removed from the local URL white list 410 since this page is no longer a valid page for viewing. If at step 1008 the web page is not found in the local URL white list, then at step 1012 the filtering process ends.

Referring now to FIG. 11, a flowchart depicting the method of filtering continued from consolidated concurrent processes A and B 704 in FIG. 7 and FIG. 8 is shown. At step 1100
20 the requested web page is added to the local URL white list 410 since the web page was either: a) found in the local domain white list 406; b) found in the local URL white list 410; c) found in the remote URL gray list 110; or d) not found in the remote URL black list. Next at step 1102 all the words in the web page that are found in the local word black list 414 are replaced
25 by blocking characters, such as the number sign (#). At step 1104 the number of black list words is counted. If at step 1106 it is determined that the number of black list words exceeds a certain threshold limit, then at step 1108 the web page is added to the local URL black list 408. Excellent results can be obtained when the threshold limit is set to 10 words. Next at step 1110 a page is shown to the user indicating that the selected web page is blocked from viewing since
30 too many words in the black list were found on the requested web page, and at step 1012 the filtering process ends.

If at step 1106 the number of words does not exceed the threshold then at step 1114 it is determined if at least one black list word was found. If no black list words were found, then at

step 1116 the filtered web page is displayed and at step 1118 the filtering process ends. If at step 1114 at least one black list word was found, then at step 1120 all the words in the web page found in the local word gray list 412 are replaced by blocking characters, such as the number sign (#). Then at step 1122 the filtered web page is displayed to the user and at step

5 1124 the filtering process ends.

In order to improve performance and speed of the filtering process discussed herein, various modifications to provide a fast and reliable filtering system can be done. For example, the filtering of a web page can be separated into multiple filtering processes. As a web page is downloaded from the Internet, then information is send from the server to the client computer

10 in packets. The filtering process can be performed separately on each packet as the web page is being downloaded from the Internet. Additional modifications include adjusting the threshold word limit discussed earlier.

We Claim:

1. A system for filtering requested information through a web browser comprising:
a filter database containing information for filtering the requested information; and
5 a filtering engine for filtering the requested information using the filter database and
passing filtered requested information to the web browser for viewing.

2. The system of claim 1, wherein the filter database includes a local filter database that is
locally accessible and a remote filter database that is remotely accessible.
10

3. The system of claim 2, wherein the local filter database includes:
a local domain white list containing domain names that have acceptable content for
viewing through the web browser;
a local uniform resource locator black list containing uniform resource locators that
15 have content not acceptable for viewing through the web browser;
a local uniform resource locator white list containing uniform resource locators that
have content acceptable for viewing through the web browser;
a local word gray list containing words that may need to be filtered from viewing
through the web browser as defined by the filtering engine; and
20 a local word black list containing words that are not acceptable for viewing through the
web browser.

4. The system of claim 3, wherein the remote filter database includes:
a remote domain white list containing domain names that are acceptable for viewing
25 through the web browser;
a remote uniform resource locator gray list containing uniform resource locators that
may need to be filtered from viewing through the web browser as defined by the filtering
engine; and
a remote uniform resource locator black list containing uniform resource locators that
30 have content not acceptable for viewing through the web browser.

5. A method of filtering requested information for viewing in a web browser, comprising the steps of:

downloading the requested information into a hidden window;

filtering the requested information using a filtering engine into filtered information; and

5 displaying the filtered information in the web browser for viewing.

6. The method of claim 5, wherein filtering the requested information includes the steps of:

checking if the requested information has a domain name matching an acceptable

10 domain name found on a domain name white list;

processing the requested information for viewing in the web browser if there is a match with the domain name white list; and

further filtering the requested information if there is not a match with the domain name white list.

15

7. The method of claim 6, wherein further filtering the requested information includes the steps of:

checking if the requested information has a uniform resource locator matching an unacceptable uniform resource locator found on a black list;

20 blocking the requested information from viewing in the web browser if there is a match with the black list; and

further filtering the requested information if there is not a match with the black list.

8. The method of claim 7, wherein further filtering the requested information includes the step of:

25

checking if the requested information has a uniform resource locator matching an acceptable uniform resource locator found on a white list;

processing the requested information for viewing in the web browser if there is a match with the white list; and

30 further filtering the requested information if there is not a match with the white list.

9. The method of claim 8, wherein further filtering the requested information includes the step of:

checking if the requested information has a uniform resource locator matching a uniform resource locator found on a gray list;

5 processing the requested information for viewing in the web browser if there is a match with the gray list; and

further filtering the requested information if there is not a match with the gray list.

10. The method of claim 9, wherein further filtering the requested information includes the steps of:

checking if the requested information has a uniform resource locator matching an unacceptable uniform resource locator found on a remote black list;

blocking the requested information from viewing in the web browser if there is a match with the remote black list; and

15 processing the requested information for viewing in the web browser if there is not a match with the remote black list.

11. The method of claim 10, wherein processing the requested information includes the steps of:

20 checking if any words in the requested information match with words in a word black list;

blocking all of the requested information from viewing in the web browser if the number of words matching with the word black list is beyond a specified limit;

25 blocking each word matching with the word black list from viewing in the web browser if the number of words matching with the word black list is below a specified limit;

checking if any words in the requested information match with words in a word gray list;

blocking each word matching with the word gray list from viewing in the web browser if the number of words matching with the word black list is beyond a specified limit; and

30 displaying the filtered requested information for viewing in the web browser.

12. A computer-readable medium comprising program instructions for filtering requested information for viewing in a web browser, comprising the steps of:
downloading the requested information into a hidden window;
filtering the requested information using a filtering engine into filtered information; and
5 displaying the filtered information in the web browser for viewing.

13. The computer-readable medium of claim 12, wherein filtering the requested information includes the steps of:

checking if the requested information has a domain name matching an acceptable
10 domain name found on a domain name white list;
processing the requested information for viewing in the web browser if there is a match with the domain name white list; and
further filtering the requested information if there is not a match with the domain name
white list.

15

14. The computer-readable medium of claim 13, wherein further filtering the requested information includes the steps of:

checking if the requested information has a uniform resource locator matching an unacceptable uniform resource locator found on a black list;
20 blocking the requested information from viewing in the web browser if there is a match with the black list; and
further filtering the requested information if there is not a match with the black list.

15. The computer-readable medium of claim 14, wherein further filtering the requested
25 information includes the step of:

checking if the requested information has a uniform resource locator matching an acceptable uniform resource locator found on a white list;
processing the requested information for viewing in the web browser if there is a match with the white list; and
30 further filtering the requested information if there is not a match with the white list.

16. The computer-readable medium of claim 15, wherein further filtering the requested information includes the step of:

checking if the requested information has a uniform resource locator matching a uniform resource locator found on a gray list;

5 processing the requested information for viewing in the web browser if there is a match with the gray list; and

further filtering the requested information if there is not a match with the gray list.

17. The computer-readable medium of claim 16, wherein further filtering the requested information includes the steps of:

10 checking if the requested information has a uniform resource locator matching an unacceptable uniform resource locator found on a remote black list;

blocking the requested information from viewing in the web browser if there is a match with the remote black list; and

15 processing the requested information for viewing in the web browser if there is not a match with the remote black list.

18. The computer-readable medium of claim 17, wherein processing the requested information includes the steps of:

20 checking if any words in the requested information match with words in a word black list;

blocking all of the requested information from viewing in the web browser if the number of words matching with the word black list is beyond a specified limit;

25 blocking each word matching with the word black list from viewing in the web browser if the number of words matching with the word black list is below a specified limit;

checking if any words in the requested information match with words in a word gray list;

blocking each word matching with the word gray list from viewing in the web browser if the number of words matching with the word black list is beyond a specified limit; and

30 displaying the filtered requested information for viewing in the web browser.

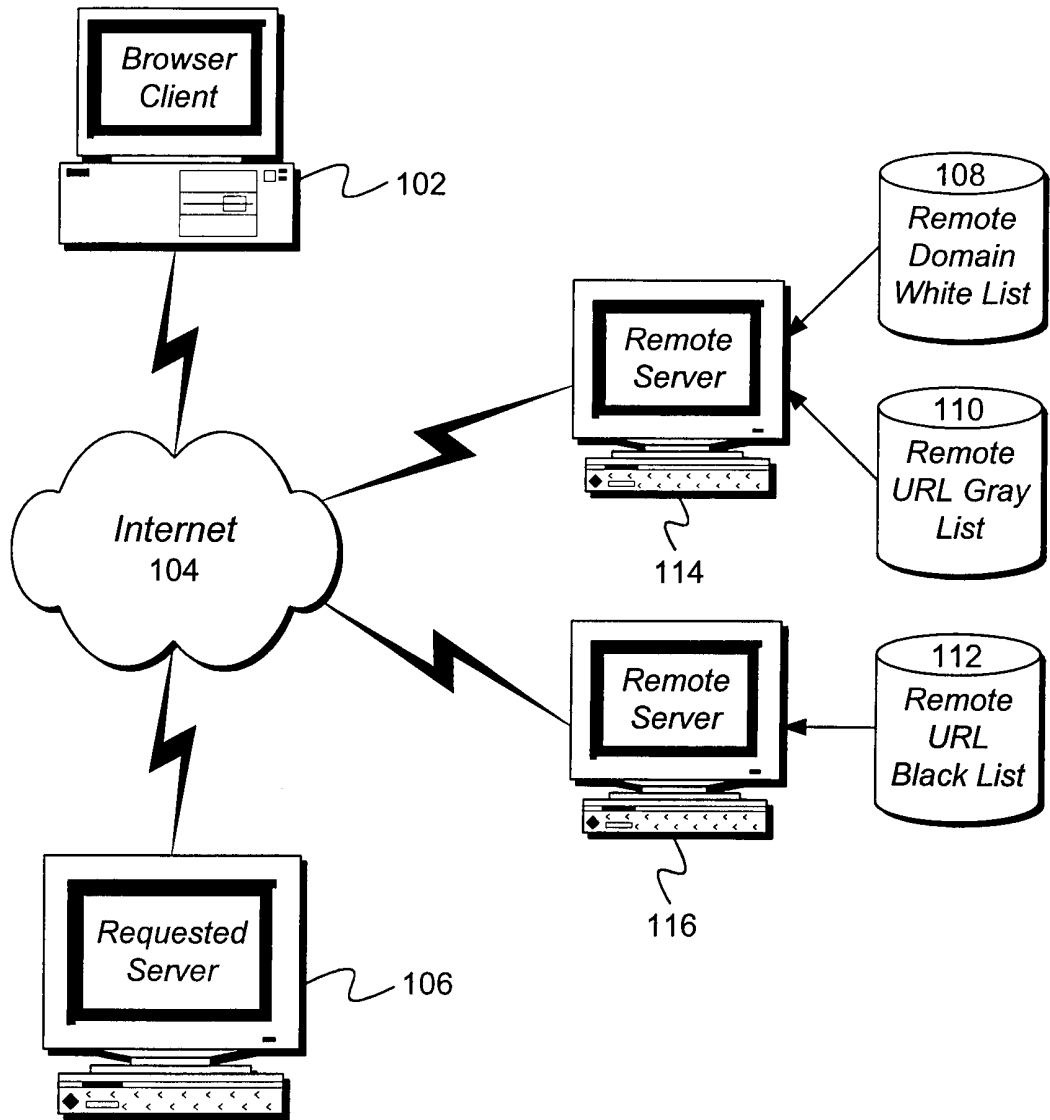

FIG. 1

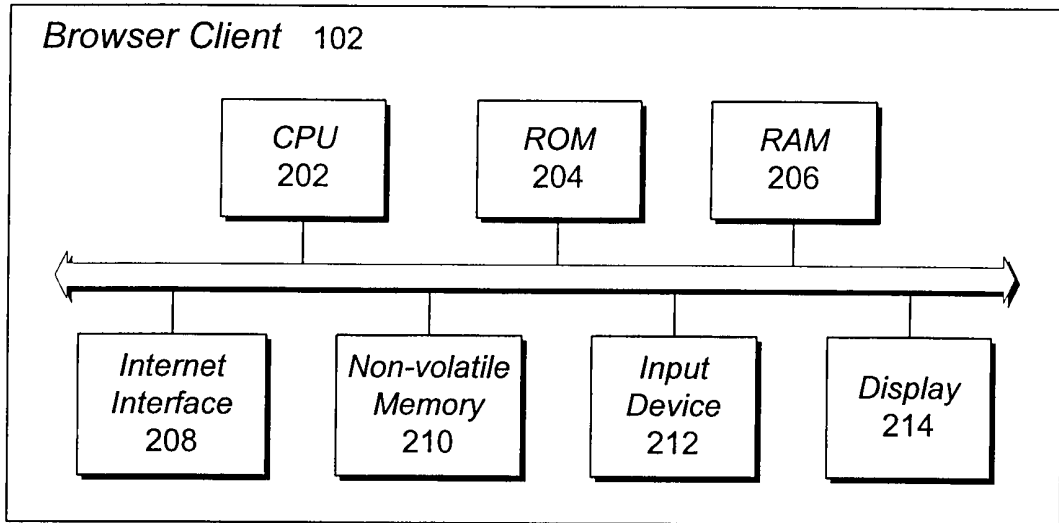

FIG. 2

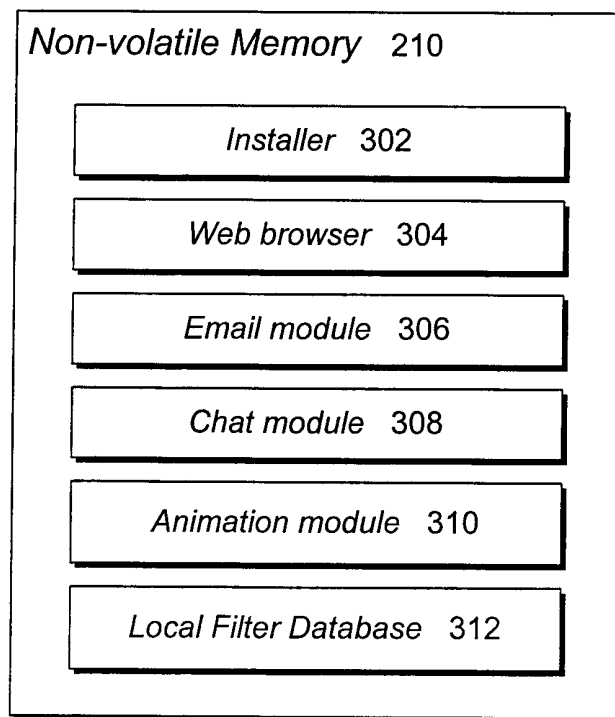

FIG. 3

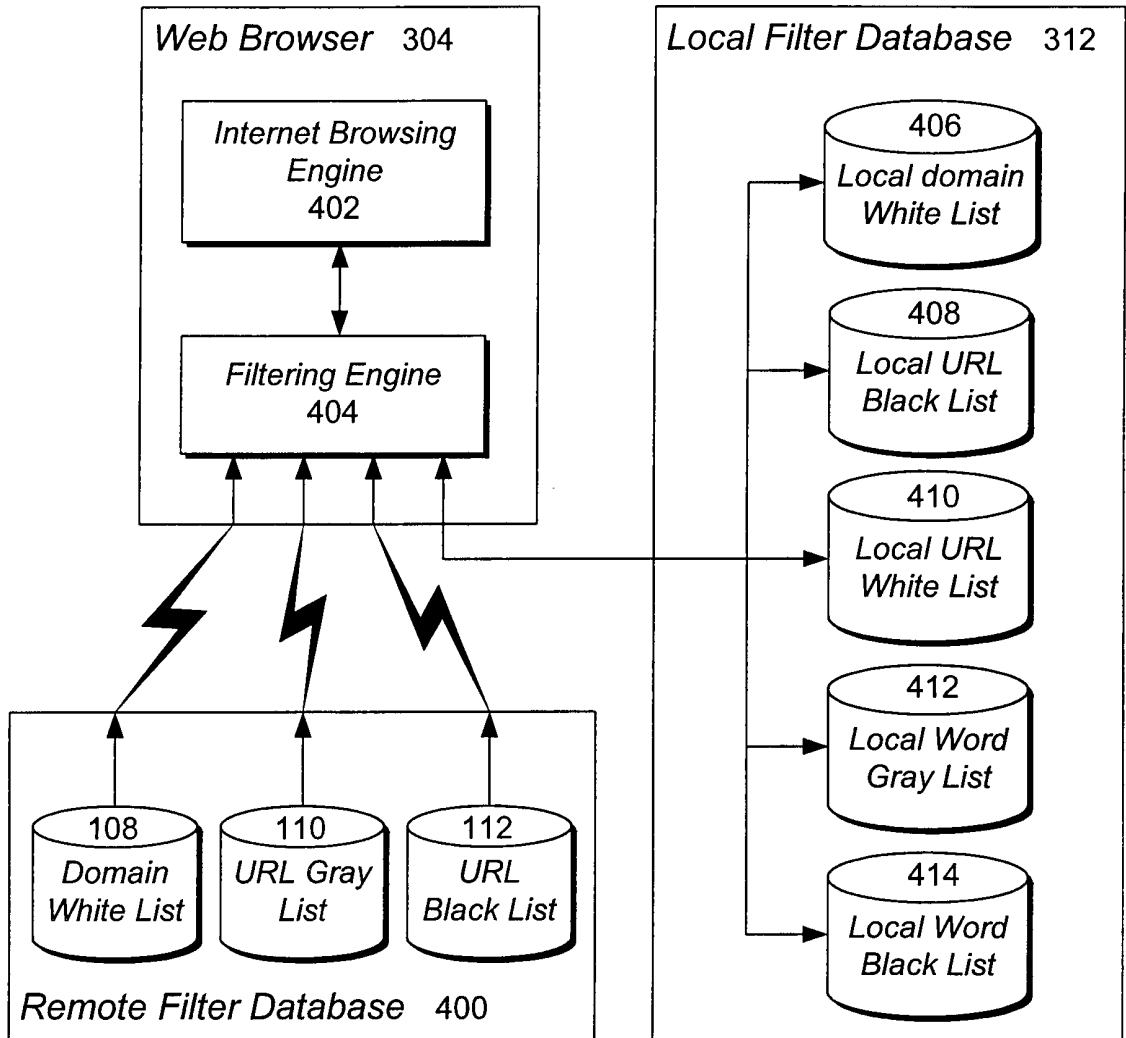

FIG. 4

4/10

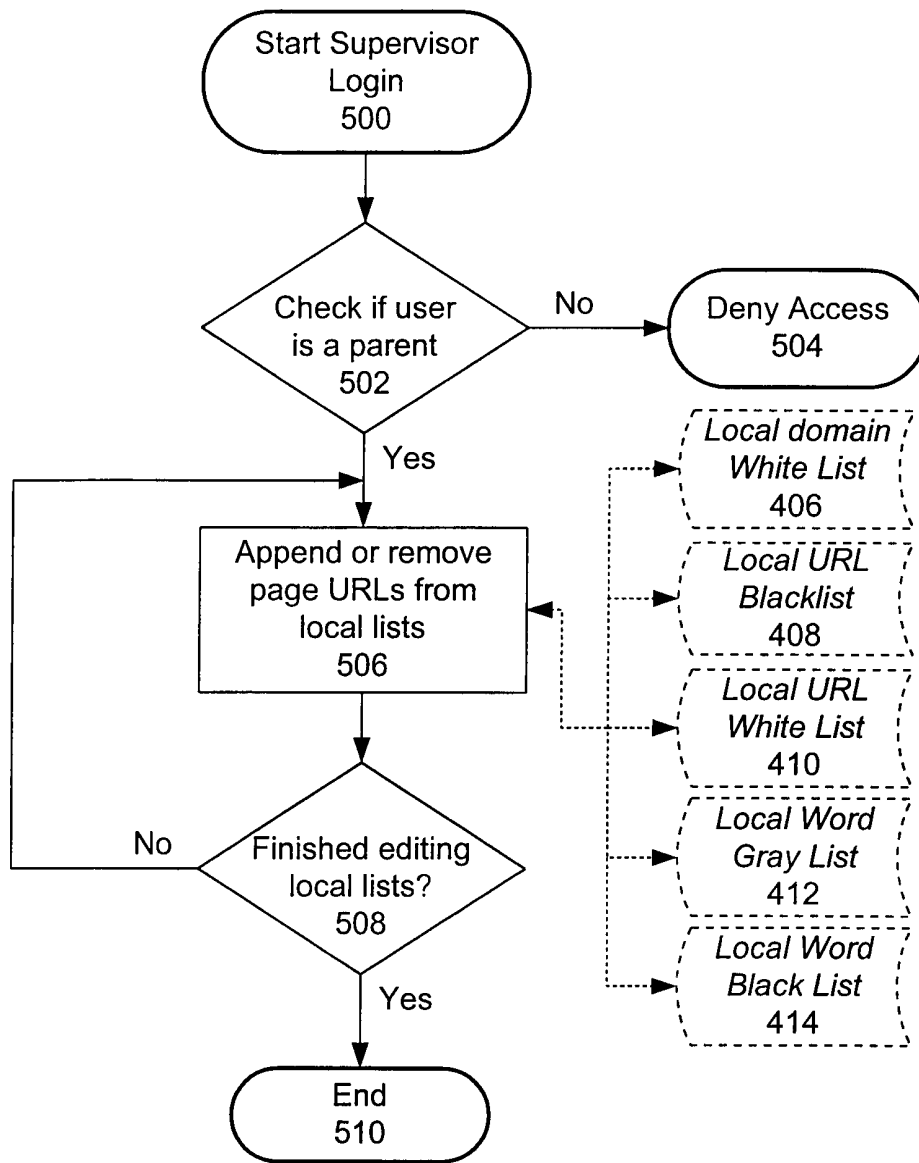

FIG. 5

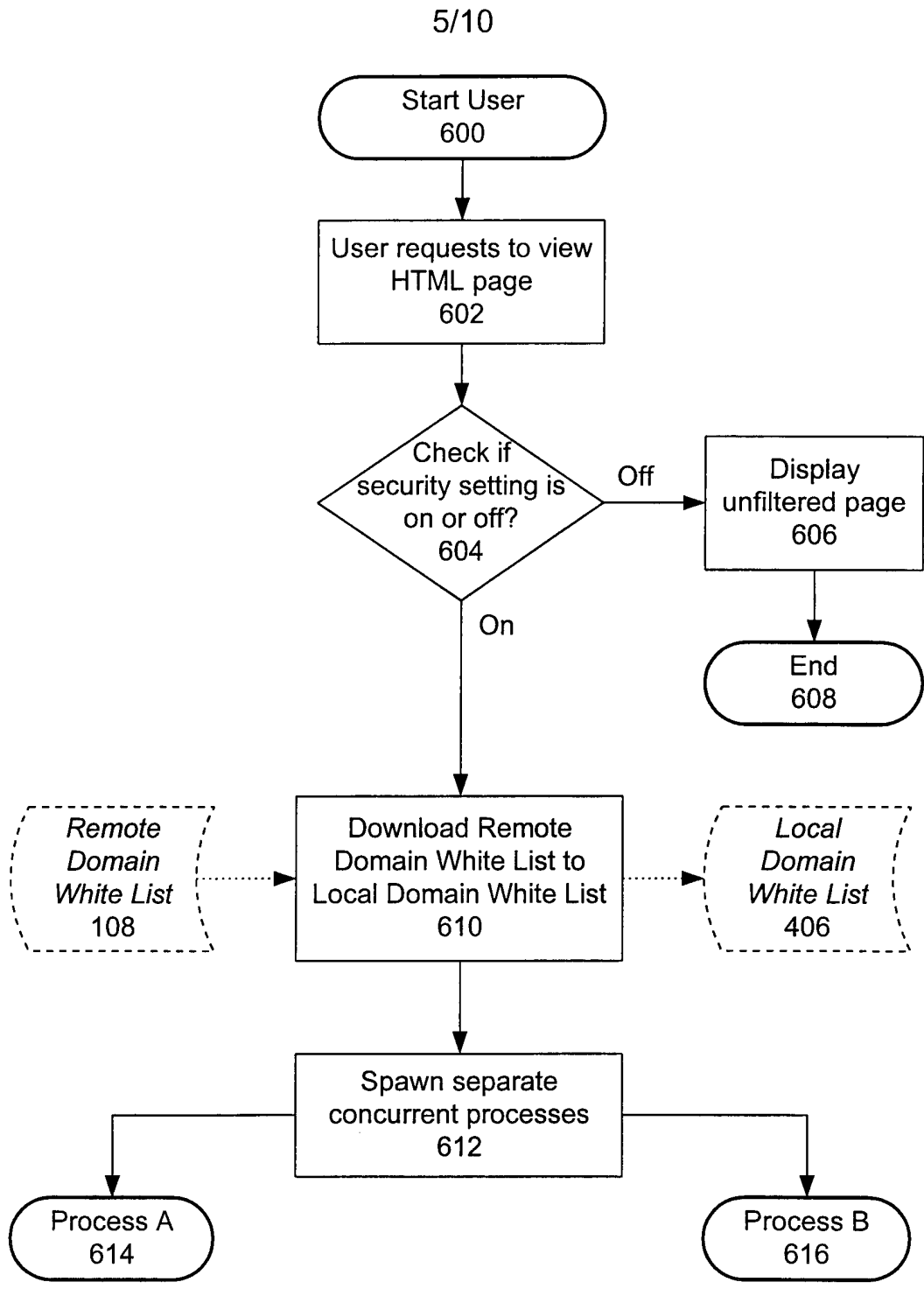

FIG. 6

6/10

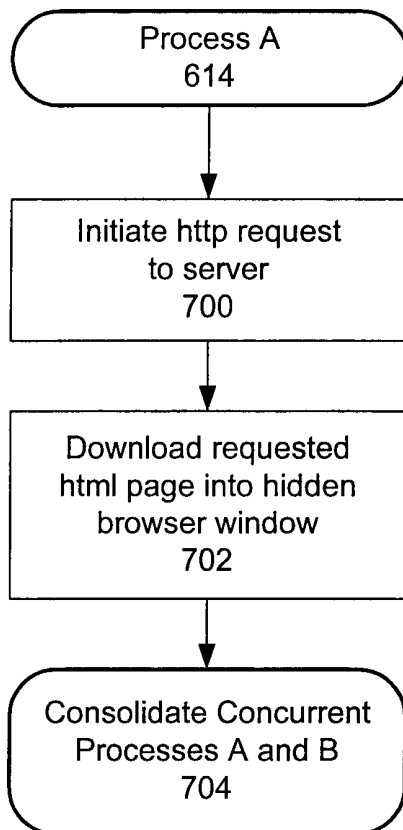

FIG. 7

7/10

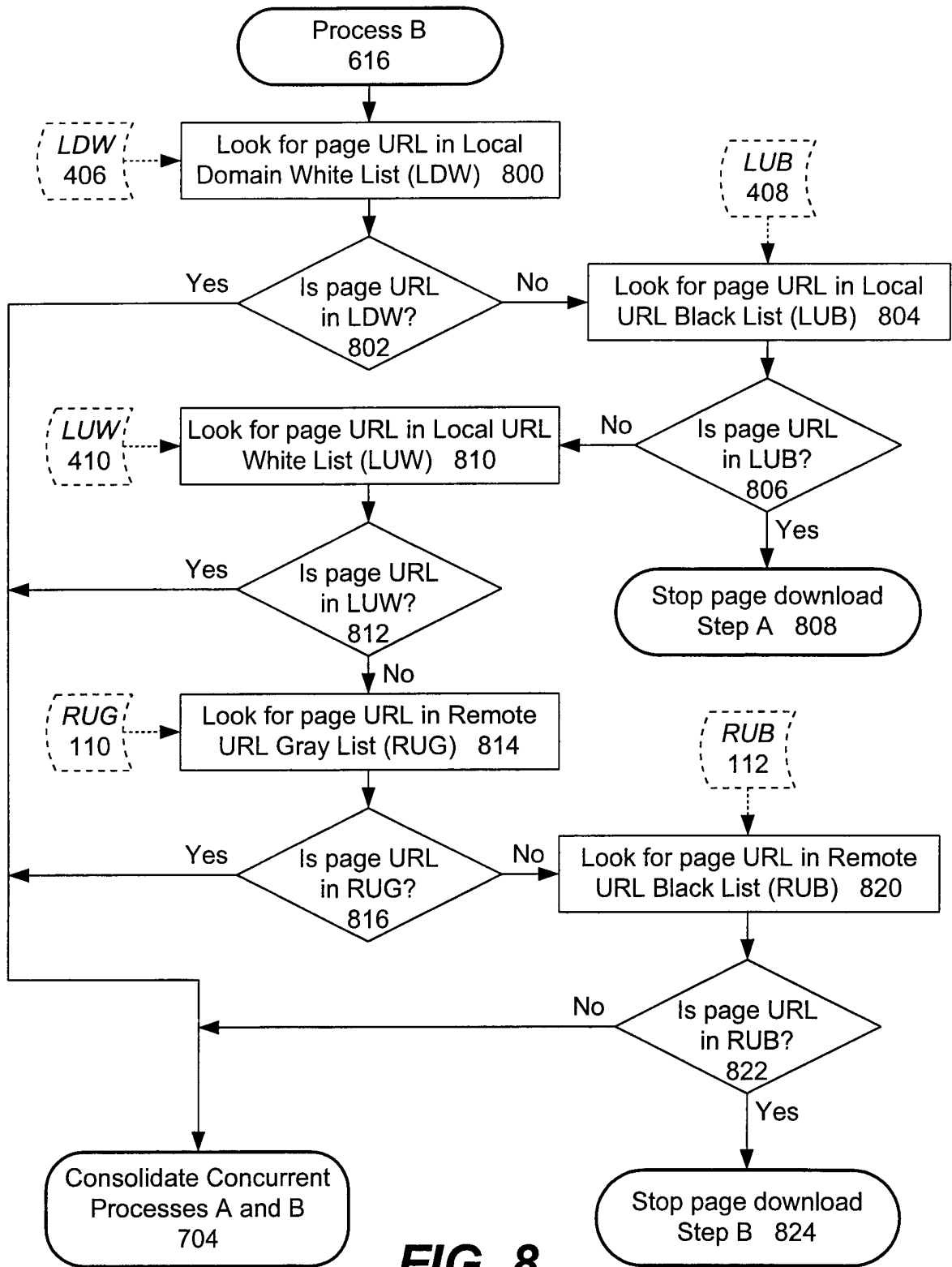

FIG. 8

8/10

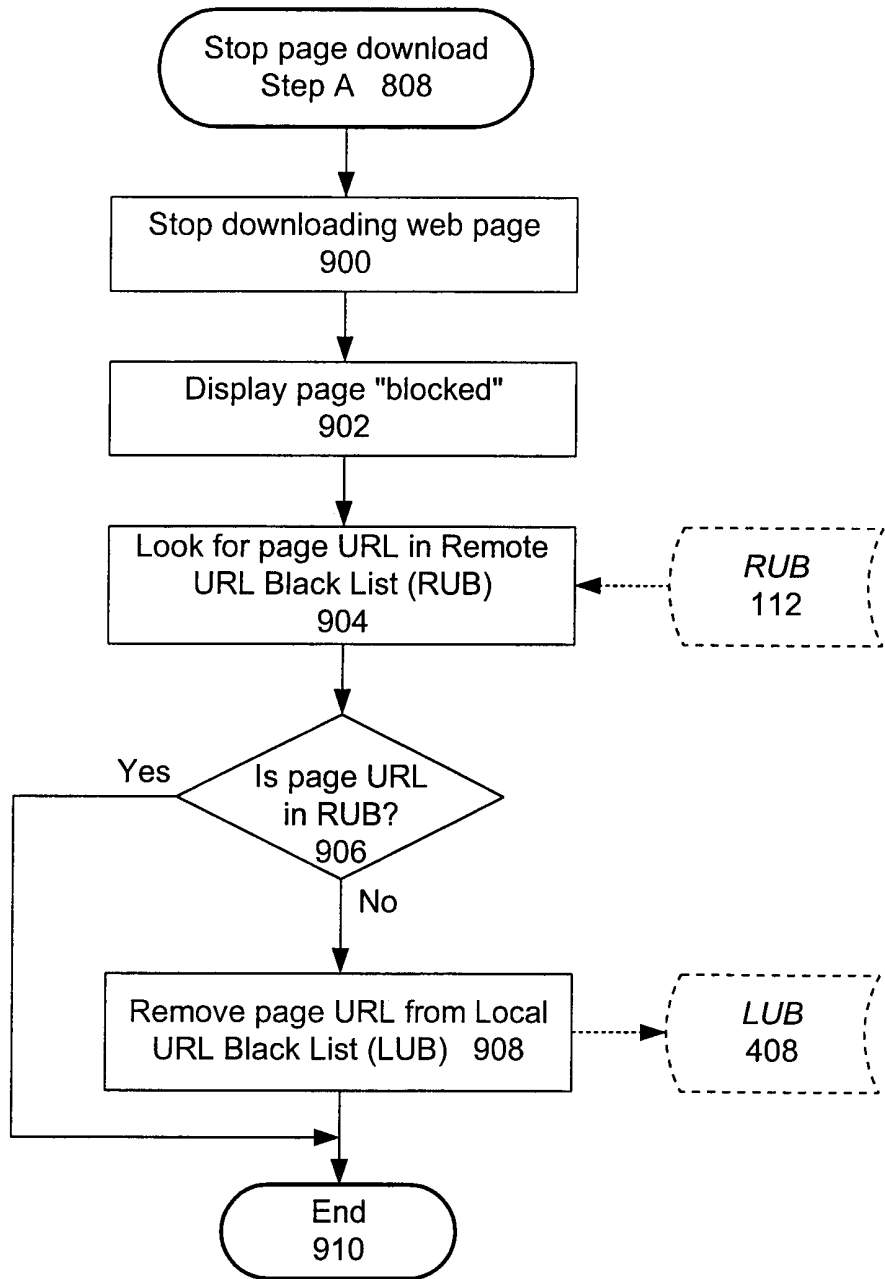

FIG. 9

9/10

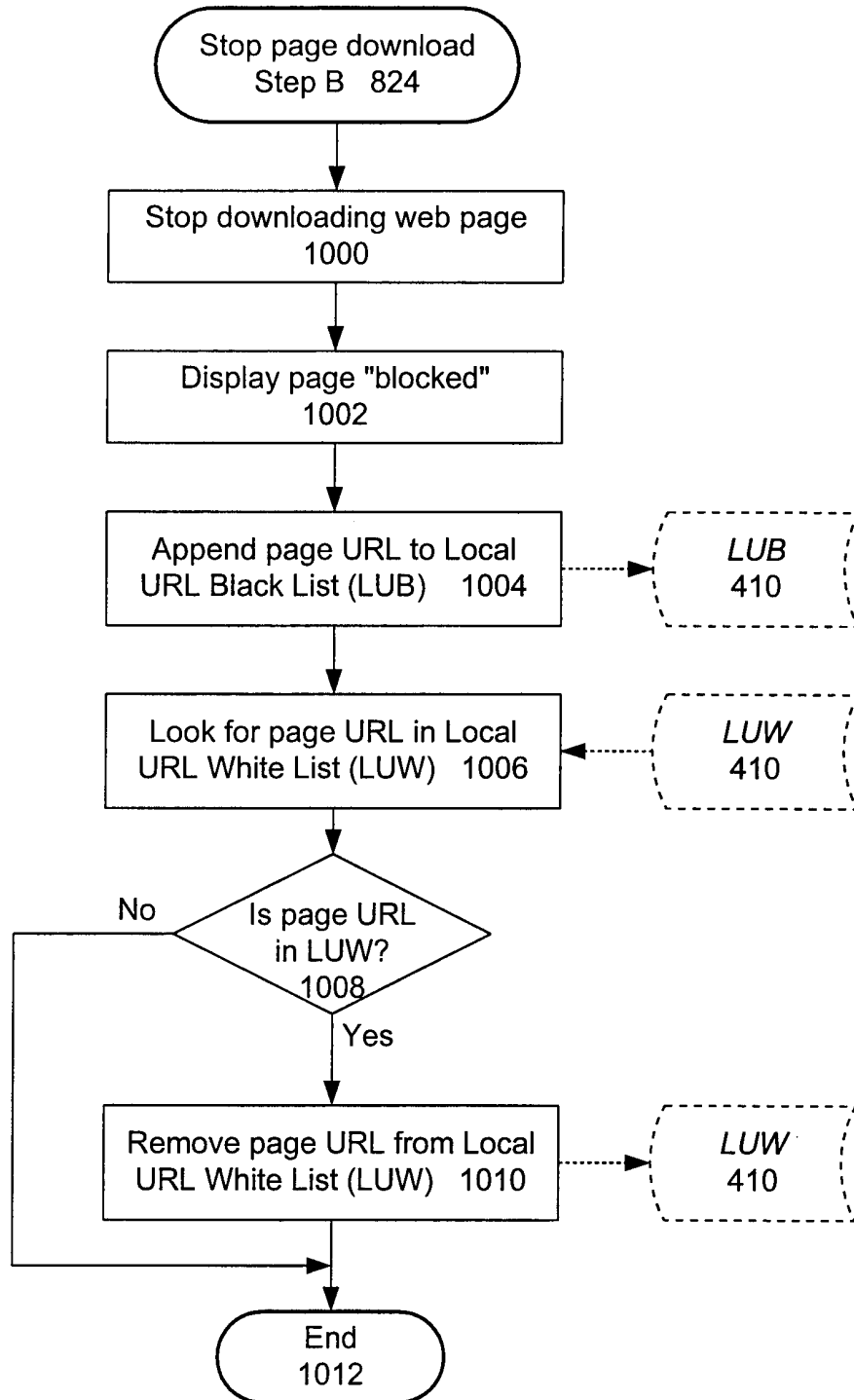

FIG. 10

10/10

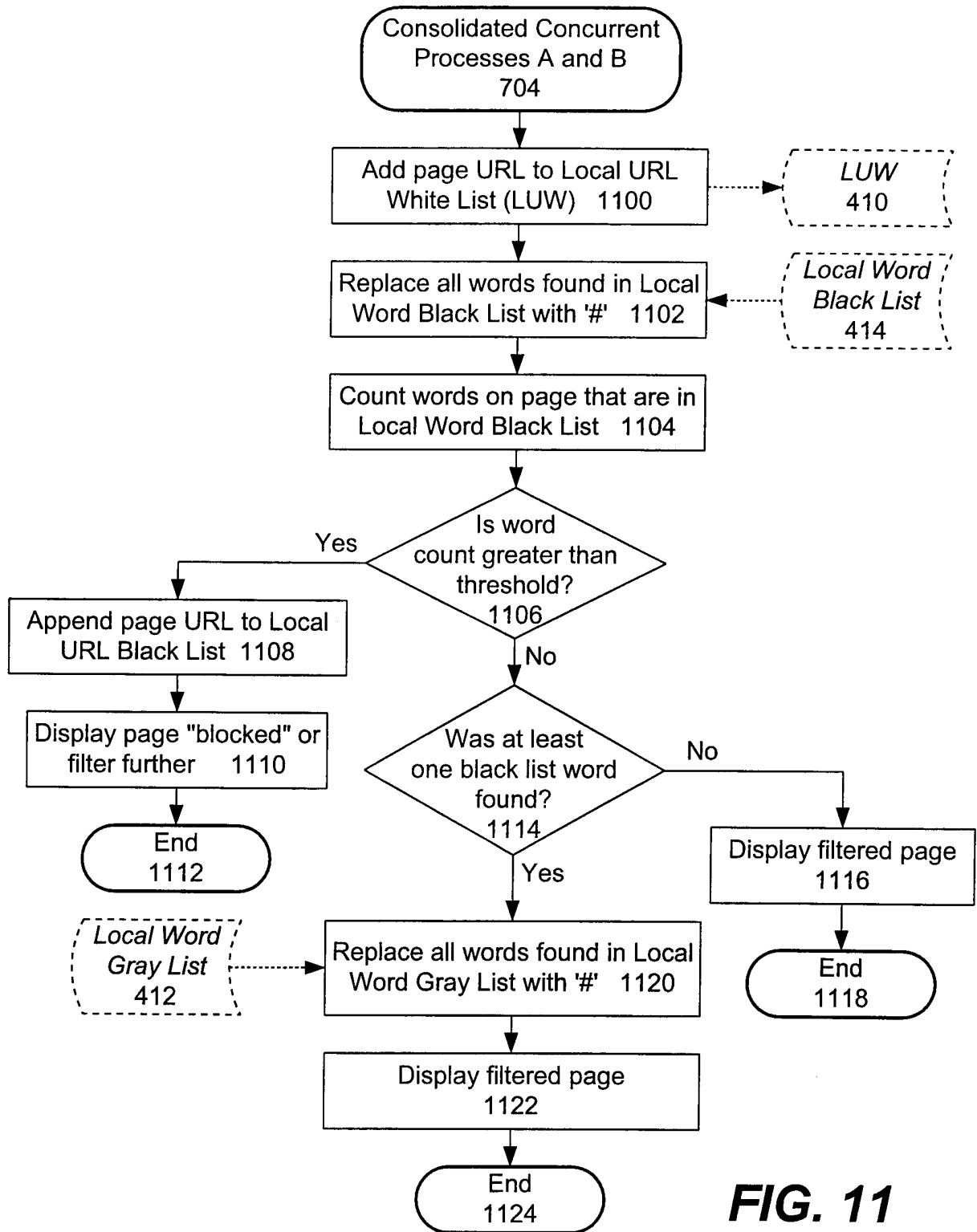

FIG. 11

INTERNATIONAL SEARCH REPORT

International application No.
PCT/US00/41274

A. CLASSIFICATION OF SUBJECT MATTER
 IPC(7) :G06F 13/00; G06F 17/30
 US CL :Please See Extra Sheet.
 According to International Patent Classification (IPC) or to both national classification and IPC

B. FIELDS SEARCHED
 Minimum documentation searched (classification system followed by classification symbols)
 U.S. : 707/104; 709/206, 224, 225

Documentation searched other than minimum documentation to the extent that such documents are included in the fields searched

Electronic data base consulted during the international search (name of data base and, where practicable, search terms used)
 WEST
 Search terms: Internet, World Wide Web, browser, filter, content, list, database, uniform resource locator, web page.

C. DOCUMENTS CONSIDERED TO BE RELEVANT

Category*	Citation of document, with indication, where appropriate, of the relevant passages	Relevant to claim No.
Y	US 5,706,507 A (SCHLOSS) 06 January 1998, col. 5, lines 24-52, col. 6, lines 7-56, col. 7, lines 1-67, col. 8, lines 1-12, col. 9, lines 4-21 and lines 59-67, col. 10, lines 1-48, col. 11, lines 56-67, and col. 13, lines 26-46.	1-18
Y	US 5,884,033 A (DUVALL et al) 16 March 1999, col. 1, lines 30-63, col. 2, lines 63-67, col. 3, lines 1-41 and lines 64-67, col. 4, lines 1-67, col. 5, lines 1-67, col. 6, lines 1-42 and lines 60-67, col. 7, lines 1-40, col. 8, lines 3-27 and lines 62-67, and col. 9, lines 47-64.	1-18

Further documents are listed in the continuation of Box C. See patent family annex.

* Special categories of cited documents:	"T" later document published after the international filing date or priority date and not in conflict with the application but cited to understand the principle or theory underlying the invention
"A" document defining the general state of the art which is not considered to be of particular relevance	"X" document of particular relevance; the claimed invention cannot be considered novel or cannot be considered to involve an inventive step when the document is taken alone
"E" earlier document published on or after the international filing date	"Y" document of particular relevance; the claimed invention cannot be considered to involve an inventive step when the document is combined with one or more other such documents, such combination being obvious to a person skilled in the art
"L" document which may throw doubts on priority claim(s) or which is cited to establish the publication date of another citation or other special reason (as specified)	"&" document member of the same patent family
"O" document referring to an oral disclosure, use, exhibition or other means	
"P" document published prior to the international filing date but later than the priority date claimed	

Date of the actual completion of the international search 08 MARCH 2001	Date of mailing of the international search report 18 APR 2001
--	--

Name and mailing address of the ISA/US Commissioner of Patents and Trademarks Box PCT Washington, D.C. 20231 Facsimile No. (703) 305-3230	Authorized officer ELLA COLBERT <i>Peggy Handal</i> Telephone No. (703) 308-7064
---	--

INTERNATIONAL SEARCH REPORT

International application No.

PCT/US00/41274

C (Continuation). DOCUMENTS CONSIDERED TO BE RELEVANT

Category*	Citation of document, with indication, where appropriate, of the relevant passages	Relevant to claim No.
Y	US 5,784,564 A (CAMAISA et al) 21 July 1998, col. 2, lines 27-48, col. 3, lines 20 -31, col. 4, lines 19-53, col. 5, lines 30-67, col. 6, lines 1-18 and lines 38-50, col. 8, lines 1-67, and col. 9, lines 1-37.	1-18

INTERNATIONAL SEARCH REPORT

International application No.
PCT/US00/41274

A. CLASSIFICATION OF SUBJECT MATTER:

US CL :

707/104; 709/206, 224, 225