

April 18, 1939.

H. LEMS

2,155,138

MERCURY CATHODE DISCHARGE TUBE

Filed June 26, 1937

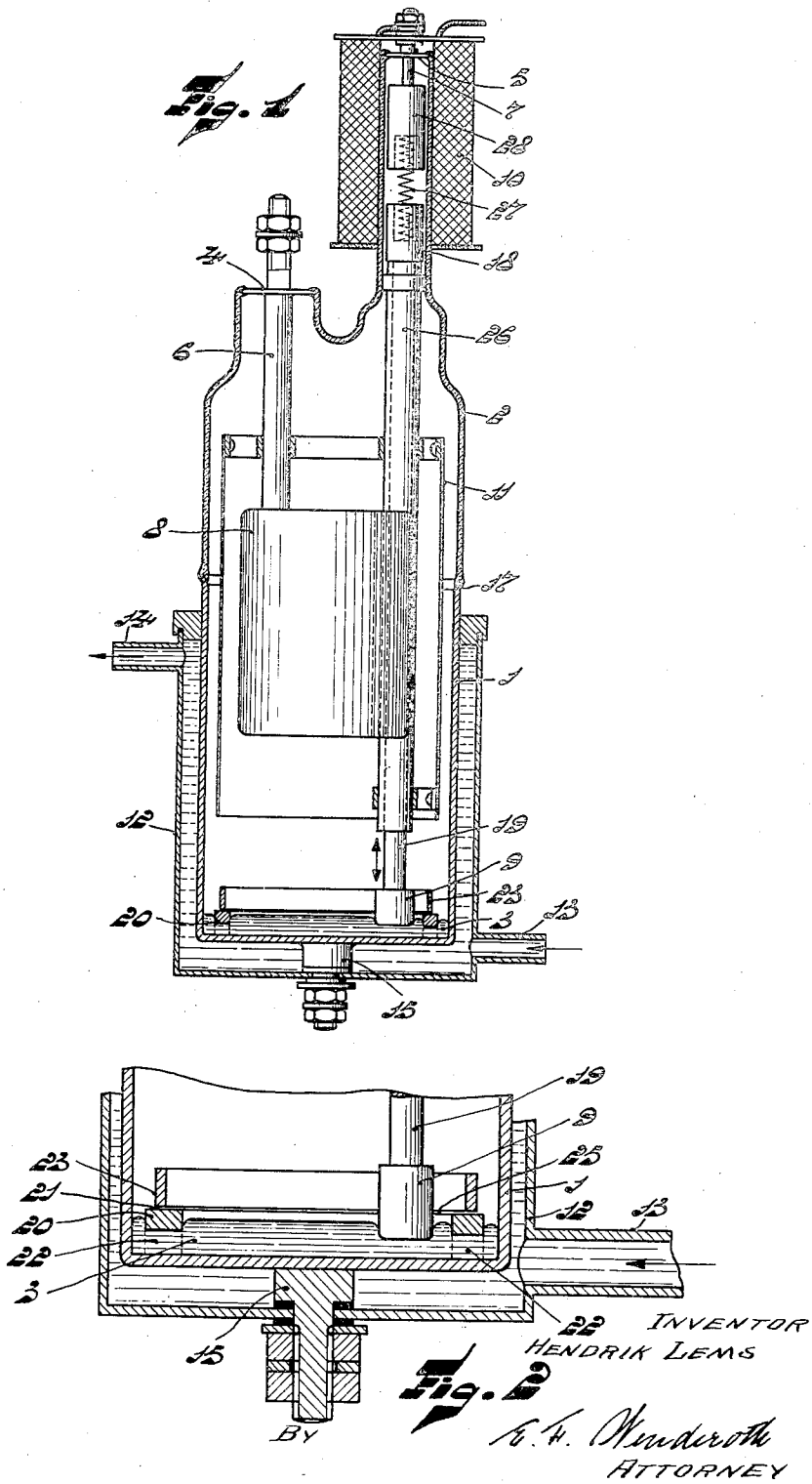

UNITED STATES PATENT OFFICE

2,155,138

MERCURY CATHODE DISCHARGE TUBE

Hendrik Lems, Eindhoven, Netherlands, assignor
to N. V. Philips' Gloeilampenfabrieken, Eindhoven, Netherlands

Application June 26, 1937, Serial No. 150,625
In Germany July 28, 1936

6 Claims. (Cl. 250—27.5)

My invention relates to mercury-cathode discharge tubes of the type in which a protective metal member is used to prevent the cathode spot from passing from a cathode-spot anchoring body over the surface of the mercury to the tube wall.

Although I shall describe my invention in connection with mercury-cathode discharge tubes in which the mercury-cathode is disposed within a cup-shaped metal envelope portion, it is not limited thereto, but is equally applicable to other types of mercury-cathode tubes.

With such tubes the anchoring body should be maintained at a low temperature so that a maximum amount of heat may be withdrawn from the mercury at the anchoring area to thereby increase the stability of the "cathode focus line". Even if this body is maintained at a low temperature and a protective ring is used, the cathode spot may leave the anchoring body for some reason or other and pass over the protective ring to reach the tube wall.

The object of my invention is to make this undesired passage of the cathode spot more difficult than in the prior art constructions without at the same time deleteriously affecting the anchoring power of the anchoring body.

According to the invention, I arrange the anchoring body in good heat-transferring relationship with the tube envelope to maintain this body at a low temperature, whereas I mount the protective ring in poor heat-transferring relationship with the envelope so that it will be maintained at a high temperature to prevent the mercury from condensing upon its surface.

In one embodiment of the invention I arrange the protective ring above the mercury cathode at such a small distance that the ring retains all its protective properties, but is in poor heat-transferring relationship therewith.

In a preferred embodiment, I use an annular anchoring body and arrange the protective ring above this body and secure it thereto by a poor heat-transmitting connection. In such a construction the protective ring separates the mercury surface within the anchoring body from the surface of the anchoring body adjacent the tube wall, while at the same time is in poor heat-transmitting relationship with the body and the tube wall.

In order that the invention may be clearly understood and readily carried into effect, I shall describe the same in more detail with reference to the accompanying drawing, in which:

Figure 1 is a sectionized view of a mercury-

cathode rectifier tube embodying the invention; and

Fig. 2 is a view of a portion of Fig. 1 drawn to actual size.

The rectifier illustrated in Figure 1 has an envelope comprising a cup-shaped metal member 1, for instance of chrome iron, and a glass member 2 hermetically fused together at 17. Disposed in the bottom of member 1 is a mercury cathode 3, whereas a main anode 8 is supported from the lower end of a conductor 6 whose upper end is secured to a metal disc 4 hermetically sealed in glass portion 2 carrying a suitable terminal. Supported from conductor 6 and surrounding anode 8 is cylindrical screen 11 serving to protect the higher internal surfaces of portion 1 and seal 17 from the detrimental effects of the discharge.

Supported by screen 11, which is preferably of sheet molybdenum, is an insulating tube 26 through the bore of which extends a conductive rod 19 carrying on its lower end an auxiliary anode 9. Anode 9 is adapted to be moved in the direction of the double-headed arrow, and for this purpose carries on its upper end a plunger 18 of magnetic material electrically connected through a compression spring 27 to a core 28 of magnetic material. Core 28 is supported from the lower end of a conductive rod 7 secured to a disc 5 hermetically sealed in glass portion 2. Outside the envelope and surrounding core 28 is coil 10 which serves to raise anode 9 from the surface of the mercury.

Surrounding cup-shaped member 1 is a cooling jacket 12 having an inlet opening 13 and an outlet opening 14, and through which a cooling medium, such as water, is circulated in the direction of the arrows during operation of the rectifier. Jacket 12 is secured to member 1 by a copper bolt 15 secured, for instance by welding, to the bottom of member 1 and serving to supply current to cathode 3.

As shown more clearly in Fig. 2, which shows a portion of Fig. 1 in actual size, an annular anchoring body 20, for instance of nickel, is provided with recesses 22 and is secured in good heat-transferring relationship to the inner surface of the cup-shaped member 1. Disposed above body 20 with an intermediate space 21 of a fraction of a millimeter, for instance 0.2 mm., is a protective ring 23 of iron. Ring 23 is secured to body 20 by a poor heat-transmitting connection, for example by means of three spot-welds 25 evenly distributed about the circumference.

In the construction shown, bodies 20 and 23 are

annular; however they may be of other closed forms, e. g. a polygon.

The cathode mercury 3 is so arranged in member 1 as to cover recesses 22, whereas the anchoring body 20 extends slightly above its surface. Thus, the mercury which flows down the inner surface of member 1 is permitted to flow back to the center of the mercury-cathode without affecting the delimiting of the mercury surface by the anchoring body. A further obstacle against passage of the cathode-spot to the tube wall is presented by the protective ring 23, which does not engage the cathode mercury at all.

This arrangement insures excellent cooling of the anchoring body 20, while at the same time insures that the protective ring 23 will be maintained at the highest temperature obtainable without a separate heating device. Because of the intermediate space 21 and the fact that the protective ring is not immersed in the mercury, there will be substantially no transfer of heat energy from the ring to the mercury and thus to the artificially-cooled tube wall.

The functioning of an arrangement such as illustrated in the drawing, may be explained as follows: It is necessary that the protective ring at the cathode surface have a very high temperature in order that mercury particles will not condense thereon and make the interruption of the mercury surface by the ring in the direction of the tube wall ineffective, whereby the cathode-spot might readily pass outwardly on the mercury surface thus formed and eventually reach the tube wall. With the construction according to the invention, the protective ring is maintained at a relatively high temperature which eliminates the above difficulty.

In prior constructions the ring, similar to the anchoring body, was partially immersed in the cathode mercury, whereby it was able to transmit a considerable part of its heat to the mercury, particularly in those cases in which the mercury was artificially cooled, for example by a circulating liquid as shown in the drawing. It will be noted that the construction illustrated has the advantage that the anchoring body and the protective ring occupy no more space in a radial direction than does the anchoring body itself. Furthermore, the thermal conditions are exceptionally good because the anchoring body is in direct contact with the cooled tube wall, whereas the protective ring with its much higher temperature, is connected to the tube only through the anchoring body. Thus, with a correct construction of the poor heat-transmitting connection between the ring and anchoring member, a maximum temperature of the protective ring is insured.

Instead of using the construction shown in the drawing, a poor heat-transmitting connection between ring 23 and body 20 can also be established by means of comparatively long connecting pieces of metal or insulating material. I prefer, however, to use the construction illustrated.

While I have described my invention with reference to specific examples and applications, I do not wish to be limited thereto, but desire the appended claims to be construed as broadly as permissible in view of the prior art.

What I claim is:

1. A mercury-cathode discharge tube compris-

ing an envelope an anode, a mercury-cathode within said envelope, a cathode-spot anchoring body extending from the surface of said mercury-cathode and secured to said envelope in good heat-transferring relationship, and means to prevent passage of the cathode-spot to the tube wall comprising a metal protective member mounted in poor heat-transferring relationship with said mercury cathode, anchoring body, and tube wall.

2. A mercury-cathode discharge tube comprising an envelope having a cup-shaped metal portion, an anode, a mercury cathode within said cup-shaped portion, a cathode-spot anchoring body secured in good heat-transferring relationship with said cup-shaped portion and extending slightly from the surface of the mercury-cathode, and means to prevent passage of the cathode-spot to the tube wall comprising a metal protective member in poor heat-transferring relationship with said mercury-cathode, anchoring body, and tube wall.

3. A mercury-cathode discharge tube comprising an envelope, an anode, a mercury-cathode within said envelope, a cathode-spot anchoring body secured in good heat-transferring relationship with said envelope, said body extending slightly from the surface of the mercury and surrounding a portion of said surface, means to prevent passage of the cathode-spot to the tube wall comprising a metal protective member disposed above the surface of the mercury with a small clearance from said body, and supporting means of low heat conductivity for said member.

4. A mercury-cathode discharge tube comprising an envelope, an anode, a mercury-cathode within said envelope, an annular cathode-spot anchoring body secured in good heat-transferring relationship with said envelope and extending slightly from the surface of the mercury, a metal protective ring disposed above the surface of the mercury and surrounding the portion of the mercury surface enclosed within said anchoring body, said protective ring being spaced a small distance from the exposed surface of said anchoring body, and means of low heat conductivity supporting said protective ring.

5. A mercury-cathode discharge tube comprising an envelope, an anode, a mercury-cathode disposed in said envelope, an annular cathode-spot anchoring body secured to said envelope in good heat-transferring relationship and extending slightly above the surface of the mercury cathode, a protective metal ring disposed above said body with a clearance of a fraction of a millimeter, and means of low heat conductivity supporting said ring from said body.

6. A mercury-cathode discharge tube comprising an envelope having a cup-shaped metal portion, an anode, a mercury-cathode within said portion, an annular cathode-spot anchoring body secured to said portion in good heat-transferring relationship and extending slightly above the surface of the mercury, a metal protective ring disposed above said body with a clearance of the order of a fraction of a millimeter, and means of low heat conductivity supporting said ring from said body and comprising a plurality of interspaced spot-welds.

HENDRIK LEMS.