

*A. M. Allen,*

*Treadle.*

*No. 108427.*

*Patented Oct. 18. 1870.*

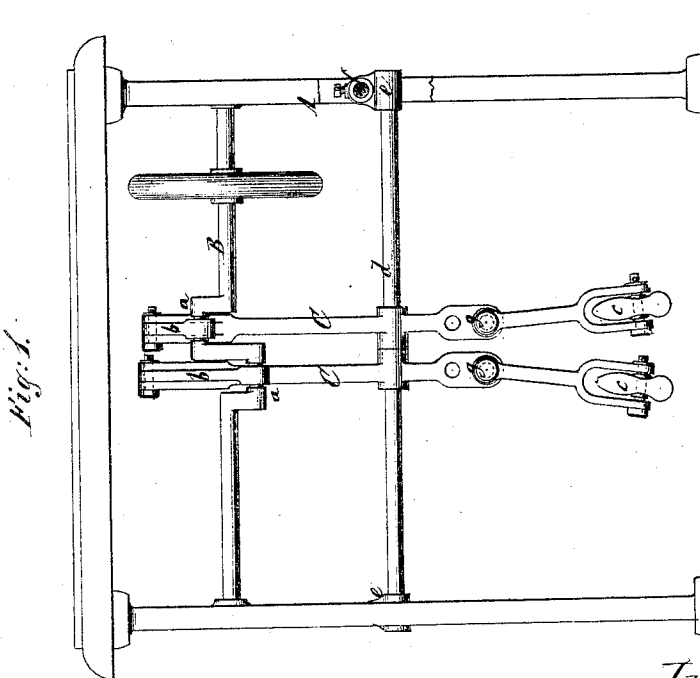
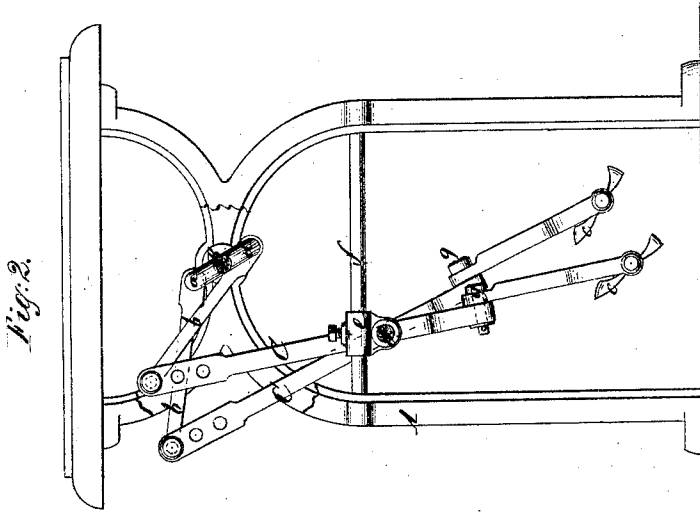

*Witnesses:*  
*A. Mahlers.*  
*E. J. Kastenhuber*

*Inventor.*  
*Arthur M. Allen*  
*San Francisco & Haupp*  
*WV*

# United States Patent Office.

ARTHUR M. ALLEN, OF NEW YORK, N. Y.

Letters Patent No. 108,427, dated October 18, 1870.

## IMPROVEMENT IN TREADLE MOTIONS.

The Schedule referred to in these Letters Patent and making part of the same

### To all whom it may concern:

Be it known that I, ARTHUR M. ALLEN, of the city, county, and State of New York, have invented a new and improved Treadle Motion; and I do hereby declare the following to be a full, clear, and exact description thereof, which will enable those skilled in the art to make and use the same, reference being had to the accompanying drawing forming part of this specification, in which drawing—

Figure 1 represents a front view of this invention, partly in section.

Figure 2 is a sectional side elevation of the same.

Similar letters indicate corresponding parts.

This invention relates to a treadle motion, in which two foot pendulums are used which connect with the crank-shaft by connecting-rods, in such a manner that the motion of the feet in operating said foot-pendulums is similar to that of the feet while walking, and consequently the operation of my treadle motion is easier and less fatiguing than that of an ordinary treadle.

The foot-pendulums have their fulcrums on a rod supported in bearings, which can be moved toward and from the operator, so that the pedals attached to said pendulums can be brought in the required position to suit operators of different stature.

Said foot-pendulums are made in two parts, connected to each other by pivots or hinge-joints, so that the distance between the pedals can be readily adjusted to suit the convenience of the operator.

In the drawing—

The letter A designates a frame, which forms the bearings for a shaft, B, in which are formed two cranks *a*, which are by preference set in opposite directions, but which may be arranged in any desirable position in relation to each other.

Said cranks connect by rods *b* with the upper ends of pendulums C, to the lower ends of which are secured pedals which I term "foot-pendulums."

The fulcrum of my foot-pendulums is on a rod, *d*, which has its bearings in brackets *e*, that are adjustable on rods *f*, secured between the legs or side pieces of the frame A, being set in the required position by set-screws, or any other suitable means.

By these means the pedals can be brought closer to or further from the front of the frame A, and they can be easily adjusted to suit the stature or convenience of the operator.

The stroke or amount of motion of the pedals may also be changed by bringing the connection of the rods *b*, with the foot-pendulums, closer to or further from the fulcrum *d*. The same effect will be produced by changing the length of the pendulums below the fulcrum *d*.

Said foot-pendulums are made in two parts, which are connected by hinge-joints or pins *g*, so that the distance between the pedals can be increased or decreased to suit the convenience of the operator.

By these means a treadle motion is obtained which allows of imparting a powerful motion to the crank-shaft from a sitting position with comparatively little exertion, the motion of the feet being the same as in walking.

What I claim as new, and desire to secure by Letters Patent, is—

1. The foot-pendulums C, in combination with the double crank-shaft B, substantially as shown and described.
2. The brackets *e* and rods or supports *f*, in combination with the rod which forms the fulcrum of the foot-levers, substantially as set forth.
3. The arrangement of a hinge-joint in the foot-pendulums, to allow of spreading or closing up the pedals, as described.

ARTHUR M. ALLEN.

Witnesses:

W. HAUFF,  
E. F. KASTENHUBER.