



(86) Date de dépôt PCT/PCT Filing Date: 2012/05/14
 (87) Date publication PCT/PCT Publication Date: 2013/11/21
 (85) Entrée phase nationale/National Entry: 2014/11/06
 (86) N° demande PCT/PCT Application No.: EP 2012/058903
 (87) N° publication PCT/PCT Publication No.: 2013/170877

(51) Cl.Int./Int.Cl. *B60S 1/40* (2006.01),
B60S 1/38 (2006.01)
 (71) Demandeur/Applicant:
FEDERAL-MOGUL S.A., BE
 (72) Inventeur/Inventor:
FRISCIONI, THOMAS, FR
 (74) Agent: SMART & BIGGAR

(54) Titre : DISPOSITIF D'ESSUIE-GLACE DE PARE-BRISE
 (54) Title: WINDSCREEN WIPER DEVICE

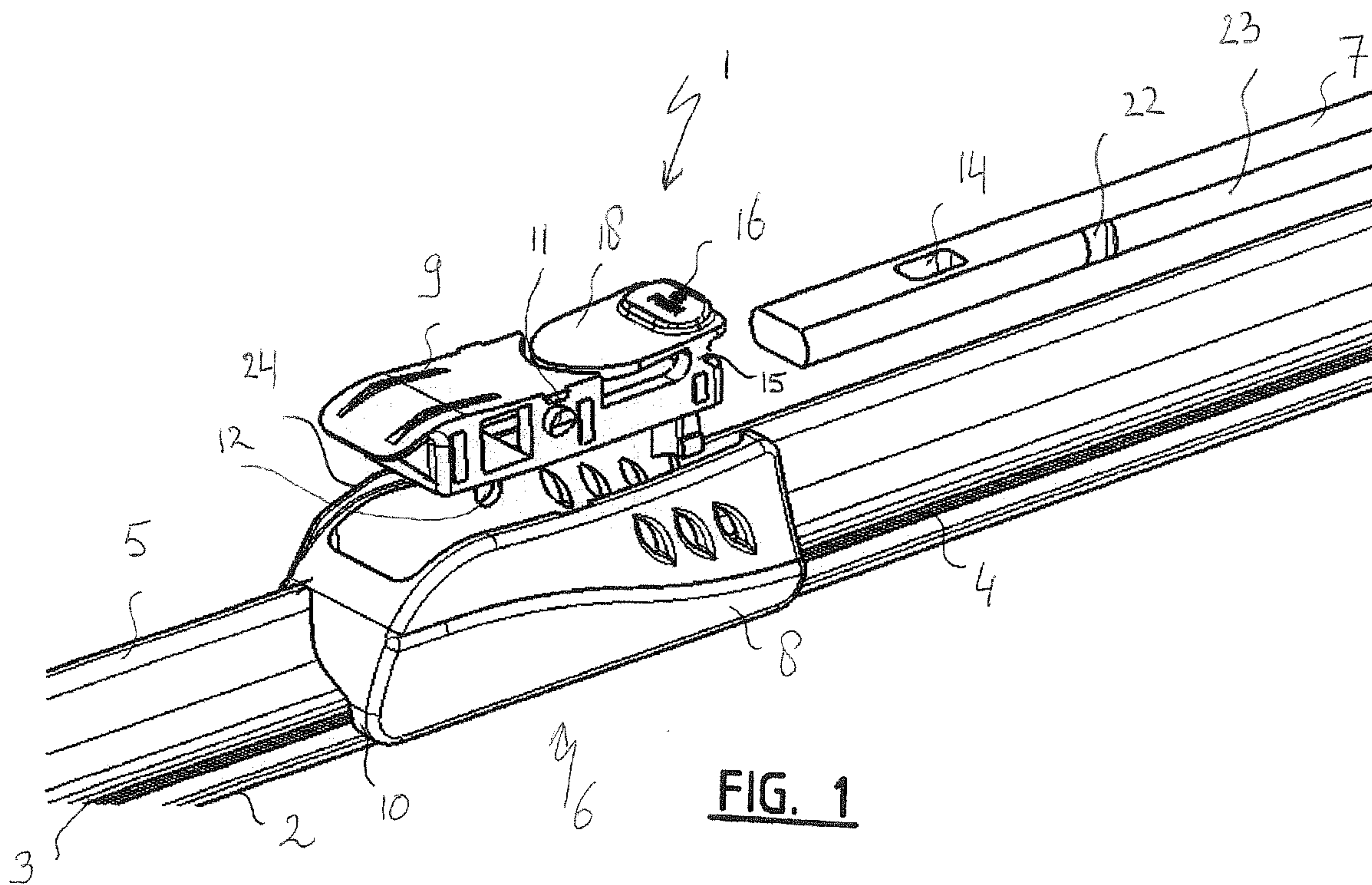

FIG. 1

(57) **Abrégé/Abstract:**

A windshield wiper device (1) comprising a wiper blade (2), which includes at least one groove (3), in which a longitudinal strip (4) is disposed, which windshield wiper device (1) comprises a connecting device (6) for an oscillating arm (7), wherein said connecting device (6) comprises at least two parts (8, 9) provided with protrusion/hole means arranged for detachably connecting said parts (8, 9) together through a snapping operation, wherein the first part (8) is retained onto the wiper blade (2) and wherein the second part (9) comprises a channel arranged for inserting said oscillating arm (7) therein.

(12) INTERNATIONAL APPLICATION PUBLISHED UNDER THE PATENT COOPERATION TREATY (PCT)

(19) World Intellectual Property
Organization
International Bureau(10) International Publication Number
WO 2013/170877 A1(43) International Publication Date
21 November 2013 (21.11.2013)

(51) International Patent Classification:

B60S 1/40 (2006.01) *B60S 1/38* (2006.01)

(21) International Application Number:

PCT/EP2012/058903

(22) International Filing Date:

14 May 2012 (14.05.2012)

(25) Filing Language:

English

(26) Publication Language:

English

(71) Applicant (for all designated States except US): **FEDERAL-MOGUL S.A.** [BE/BE]; Avenue Champion, B-6790 Aubange (BE).

(72) Inventor; and

(75) Inventor/Applicant (for US only): **FRISCIONI, Thomas** [BE/FR]; 42 Rue Marechal Foch, F-57710 Aumetz (FR).(74) Agent: **HOOIVELD, Arjen Jan Winfried**; Sweelinckplein 1, NL-2517 GK Den Haag (NL).

(81) Designated States (unless otherwise indicated, for every kind of national protection available): AE, AG, AL, AM,

AO, AT, AU, AZ, BA, BB, BG, BH, BR, BW, BY, BZ, CA, CH, CL, CN, CO, CR, CU, CZ, DE, DK, DM, DO, DZ, EC, EE, EG, ES, FI, GB, GD, GE, GH, GM, GT, HN, HR, HU, ID, IL, IN, IS, JP, KE, KG, KM, KN, KP, KR, KZ, LA, LC, LK, LR, LS, LT, LU, LY, MA, MD, ME, MG, MK, MN, MW, MX, MY, MZ, NA, NG, NI, NO, NZ, OM, PE, PG, PH, PL, PT, QA, RO, RS, RU, RW, SC, SD, SE, SG, SK, SL, SM, ST, SV, SY, TH, TJ, TM, TN, TR, TT, TZ, UA, UG, US, UZ, VC, VN, ZA, ZM, ZW.

(84) Designated States (unless otherwise indicated, for every kind of regional protection available): ARIPO (BW, GH, GM, KE, LR, LS, MW, MZ, NA, RW, SD, SL, SZ, TZ, UG, ZM, ZW), Eurasian (AM, AZ, BY, KG, KZ, RU, TJ, TM), European (AL, AT, BE, BG, CH, CY, CZ, DE, DK, EE, ES, FI, FR, GB, GR, HR, HU, IE, IS, IT, LT, LU, LV, MC, MK, MT, NL, NO, PL, PT, RO, RS, SE, SI, SK, SM, TR), OAPI (BF, BJ, CF, CG, CI, CM, GA, GN, GQ, GW, ML, MR, NE, SN, TD, TG).

Published:

— with international search report (Art. 21(3))

(54) Title: WINDSCREEN WIPER DEVICE

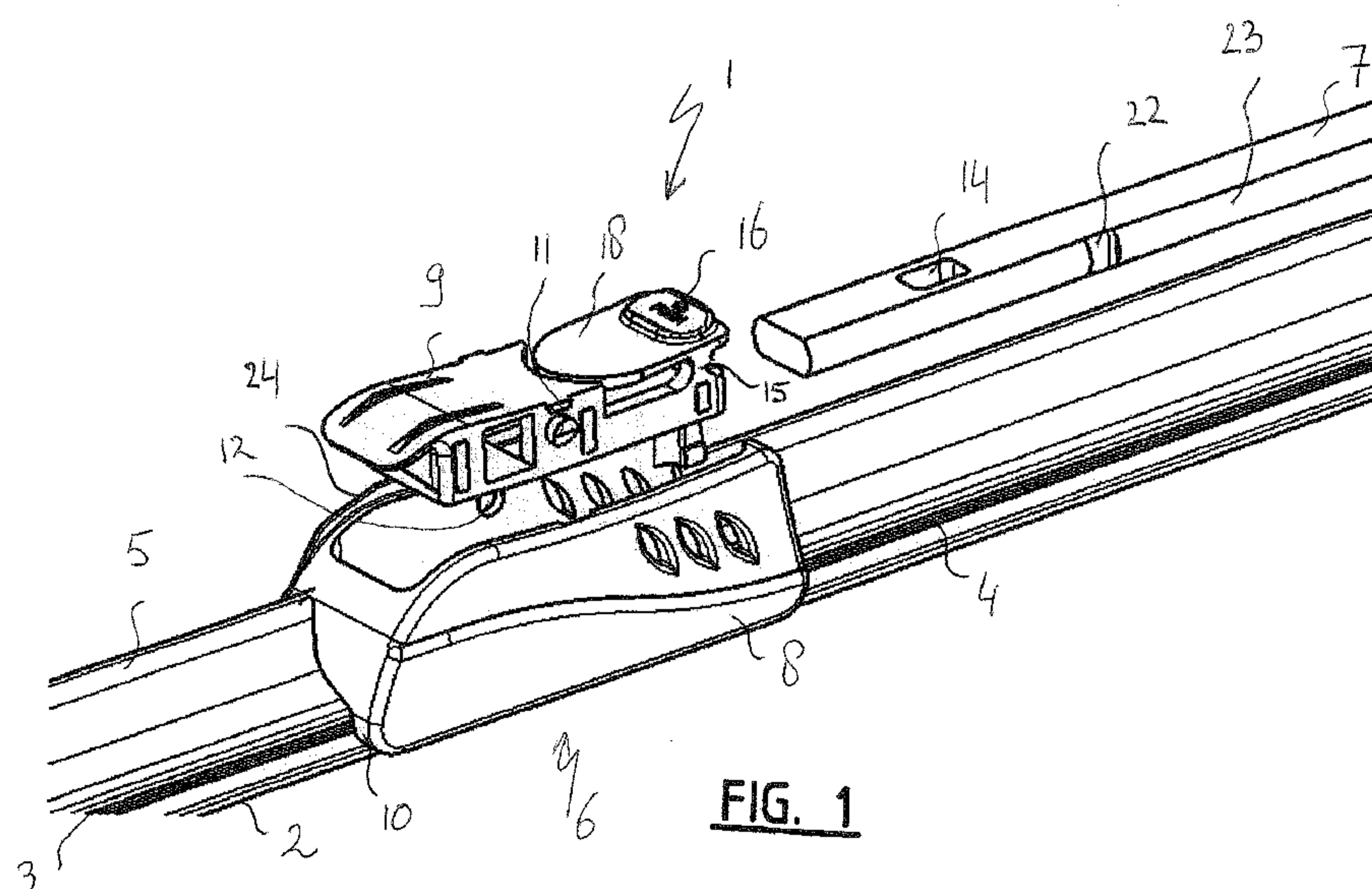

FIG. 1

(57) Abstract: A windscreen wiper device (1) comprising a wiper blade (2), which includes at least one groove (3), in which a longitudinal strip (4) is disposed, which windscreen wiper device (1) comprises a connecting device (6) for an oscillating arm (7), wherein said connecting device (6) comprises at least two parts (8, 9) provided with protrusion/hole means arranged for detachably connecting said parts (8, 9) together through a snapping operation, wherein the first part (8) is retained onto the wiper blade (2) and wherein the second part (9) comprises a channel arranged for inserting said oscillating arm (7) therein.

WINDSCREEN WIPER DEVICE

5 The present invention relates to a windscreen wiper device comprising an elastic, elongated carrier element, as well as an elongated wiper blade of a flexible material, which can be placed in abutment with a windscreen to be wiped, which wiper blade includes at least one groove, in which groove a
10 longitudinal strip of the carrier element is disposed, wherein ends of said longitudinal strip are connected by a respective connecting piece, which windscreen wiper device comprises a connecting device for an oscillating arm, wherein said oscillating arm can be pivotally connected to
15 said connecting device about a pivot axis near one end.

Such a windscreen wiper device is generally known. This prior art windscreen wiper device is designed as a "yokeless" wiper device or "flat blade", wherein no use is
20 made of several yokes pivotally connected to each other, but wherein the wiper blade is biased by the carrier element, as a result of which it exhibits a specific curvature.

In practice it has become apparent that, during use of the
25 known windscreen wiper device, high forces are exerted on the connection between the connecting device and the oscillating arm. As a consequence thereof the wiper blade may get loose from the oscillating arm.

30 The object of the invention is to provide a windscreen wiper device, wherein the connecting device and the oscillating arm are connected in an improved manner, using a minimum of parts.

Thereto, a windscreen wiper device of the type referred to in the introduction is characterized according to the invention in that said connecting device comprises at least two parts provided with protrusion/hole means arranged for detachably connecting said parts together through a snapping operation, wherein the first part is retained onto the wiper blade and wherein the second part comprises a channel arranged for inserting said oscillating arm therein, wherein said windscreen wiper device is provided with retaining means arranged for retaining said connecting device onto said oscillating arm, wherein said retaining means comprises at least one downwardly extending protrusion on the second part, wherein said protrusion is movable between an inward position, wherein in mounted position said protrusion engages into a correspondingly shaped hole provided in said oscillating arm and said connecting device is retained onto said oscillating arm, and an outward position, wherein in a dismounted position said protrusion disengages from said hole provided in said oscillating arm and said connecting device is released from said oscillating arm.

Preferably, the second part is made of plastic, wherein a part of a top wall of said second part containing said downwardly extending protrusion is allowed to hinge about a hinge axis, preferably upon activating or deactivating (particularly using a finger) a push button on said part of said top wall. More in particular, said part of said top wall comprises at a bottom side thereof said downwardly extending protrusion, as well as at a top side thereof said push button. By activating or deactivating the push button, a hinge movement or "seesaw movement" is realized. Said protrusion and said push button are preferably located at

opposite ends of said part of said top wall of said second part. Particularly, said part of said top wall of said second part is allowed to hinge along two lateral hinges on opposite sides of the oscillating arm. Said hinges located 5 laterally i.e. on each side of the oscillating arm, are preferably not visible from the outside when said first and second parts are snapped together.

Preferably, the second part has an at least substantially U- 10 shaped cross-section at the location of its connection to said first part, wherein each leg of said U-shaped cross-section is allowed to bend outwardly upon insertion of the oscillating arm into said second part for connecting said first and second parts together through a snapping 15 operation. Preferably, each leg of said U-shaped cross-section is bendable between a first position, wherein said first and second parts are connected together through a snapping operation upon insertion of the oscillating arm into said second part, and a second position, wherein said 20 first and second parts are released from each other upon removing the oscillating arm from said second part. In other words, sliding the oscillating arm into the second part of the connecting device preferably results in the legs of the U-shaped cross-section being bend outwardly. As a result the 25 first and the second parts of the connecting device are automatically snapped, that is clipped onto each other, using the protrusion/hole means. Both parts are automatically released from each other by sliding the oscillating arm off the second part of the connecting 30 device.

In the alternative, the second part has an at least rectangular, preferably square shaped cross-section, wherein

said first and second parts are connected through a snapping operation, and wherein vertical side walls of said second part are allowed to deform elastically or plastically, in order to clip said parts together, using said
5 protrusion/hole means.

It is noted that the present invention is not restricted to the use of only one longitudinal strip that is particularly located in a central, channel forming groove of the wiper
10 blade. Instead, said carrier element may comprise two, spaced-apart longitudinal strips forming the elastic, elongated carrier element, wherein said strips are disposed in opposing longitudinal grooves on longitudinal sides of the wiper blade. In the latter case said connecting device
15 may welded, soldered, brazed or glued to the longitudinal strips. In the former case, said connecting device may be welded, soldered, brazed or glued to an elastomeric material, such as rubber, of the wiper blade.

20 In a preferred embodiment of a windscreen wiper device in accordance with the invention said protrusion is hingeable between said inward position and said outward position. Particularly, said protrusion is hingeable along hinges of said second part located on opposite sides of the
25 oscillating arm in mounted position thereof, i.e. on opposite sides of the channel arranged for inserting said oscillating arm therein. Said outer edge is particularly located along an outer circumference of said second part. More in particular, said protrusion is hingeable from said
30 inward position into said outward position upon activating a push button on said second part. Such a push button can be pressed in by hand.

In another preferred embodiment of a windscreen wiper device according to the invention said retaining means form first retaining means, and wherein said windscreen wiper device is further provided with second retaining means arranged for
5 retaining said connecting device onto said oscillating arm, wherein said second retaining means comprises at least one protrusion provided on the first part arranged to engage the oscillating arm. Preferably, said protrusion on the first part is arranged to engage into a recess provided on a
10 longitudinal side of the oscillating arm. In the alternative, said protrusion on the first part is arranged to engage into a hole having a closed circumference provided in the oscillating arm.

15 In another preferred embodiment of a windscreen wiper device in accordance with the invention said protrusion on the first part is located near an insertion opening of said channel arranged for inserting said oscillating arm therein. In other words, said recess provided on a longitudinal side
20 of the oscillating arm is located at a larger distance to the free end of the oscillating arm than the hole in the oscillating arm cooperating with the protrusion on the second part. Accordingly, mounting or dismounting said connecting device onto or from said oscillating arm can be
25 effected at a certain pivot angle of the oscillating arm relative to said first part.

In another preferred embodiment of a windscreen wiper device according to the invention the second part is positioned
30 within said first part, wherein said second part has vertical side walls, wherein said first part is provided with opposite abutting surfaces for abutting against the vertical side walls of the second part, and wherein a

protrusion at the location of said pivot axis extends laterally outwardly from each side wall of the second part into a hole provided on an abutting surface abutting against a respective sidewall. In the alternative or in addition
5 thereto, said first part is provided with opposite abutting surfaces for abutting against the vertical side walls of the second part, wherein a protrusion extends laterally inwardly from each abutting surface into a hole provided on a side wall abutting against a respective abutting surface.

10 Preferably, said second part has an at least substantially U-shaped, rectangular or square cross-section at the location of its connection to said first part, wherein the vertical side walls form legs of said cross-section.

15 Preferably, one of said abutting surfaces of said first part has a larger height than the other abutting surface of said first part. Hence, a so-called "afterspray effect" is avoided, wherein rain water located on the connecting device is not allowed to splash onto the windscreen to be wiped
20 during wiping.

The present invention also refers to a wiper arrangement of a windscreen wiper device in accordance with the invention and an oscillating arm connected thereto. Particularly, for
25 mounting or dismounting said connecting device onto or from said oscillating arm, the second part of said windscreen wiper device and the free end of said oscillating arm connected thereto are arranged to be pivoted relative to said first part of said windscreen wiper device in order to
30 engage or disengage the protrusion on the first part into or from the recess on the longitudinal side of said oscillating arm. This can, of course, only be done when also the

protrusion on the second part in all embodiments is engaged into or disengaged from the hole in the oscillating arm.

The present invention is also directed to a method for
5 manufacturing a windscreen wiper device comprising an
elastic, elongated carrier element, as well as an elongated
wiper blade of a flexible material, which can be placed in
abutment with a windscreen to be wiped, which wiper blade
includes at least one groove, in which groove a longitudinal
10 strip of the carrier element is disposed, wherein ends of
said longitudinal strip are connected by a respective
connecting piece, which windscreen wiper device comprises a
connecting device for an oscillating arm, wherein said
oscillating arm can be pivotally connected to said
15 connecting device about a pivot axis near one end,
characterized in that said connecting device is made of at
least two parts provided with protrusion/hole means arranged
for detachably connecting said parts together through a
snapping operation, wherein the first part is retained onto
20 the wiper blade and wherein the second part is provided with
a channel arranged for inserting said oscillating arm
therein, wherein said windscreen wiper device is provided
with retaining means arranged for retaining said connecting
device onto said oscillating arm, wherein said retaining
25 means is provided with at least one downwardly extending
protrusion on the second part, wherein said protrusion is
movable between an inward position, wherein in mounted
position said protrusion engages into a correspondingly
shaped hole provided in said oscillating arm and said
30 connecting device is retained onto said oscillating arm, and
an outward position, wherein in dismounted position said
protrusion disengages from said hole provided in said

oscillating arm and said connecting device is released from said oscillating arm.

The invention will now be explained in more detail with
5 reference to figures illustrated in a drawing, wherein

- 10 - Figure 1 is a schematic and perspective view, partly in exploded view, of a main part of a windscreen wiper device and an oscillating arm according to the invention, wherein a first part and a second part of a connecting device of said windscreen wiper device is shown arranged to be connected to said oscillating arm;
- 15 - Figure 2 are side views of said oscillating arm inserted inside said second part of the connecting device of figure 1;
- Figure 3 corresponds to figure 2, but now showing schematic, perspective views;
- 20 - Figure 4 is a top view of figure 3;
- Figure 5 are cross-sectional views along the line A-A of figure 4;
- 25 - Figure 6 are schematic, perspective views of (a part of) the first part of said connector, as well as a view form below of said connector connected to said oscillating arm; and
- 30 - Figure 7 shows successive steps for fitting together said connecting device and said oscillating arm according to the invention.

Figure 1 shows a windscreen wiper device 1 of the "flat blade" type according to the invention. Said windscreen wiper device 1 is built up of an elastomeric wiper blade 2, in the longitudinal sides of which opposing longitudinal grooves 3 are formed, and of longitudinal strips 4 made of spring band steel, which are fitted in said longitudinal grooves 3. Said strips 4 form a flexible carrier element for the rubber wiper blade 2, as it were, which is thus biased in a curved position (the curvature in operative position being that of a windscreen to be wiped). Neighbouring ends of strips 4 are interconnected on either side of the windscreen wiper device 1 by means of connecting pieces (not shown) functioning as clamping members. In this embodiment, the connecting pieces may be separate constructional elements, which may be form-locked ("positive locking" or "having positive fit"), as well as force-locked to the ends of strips 4. In another preferred variant, said connecting pieces are in one piece with the strips 4 made of spring band steel. In the latter case said connecting pieces form transverse bridges for the strips 4, as it were. Possibly, a spoiler 5 is furthermore provided.

The windscreen wiper device 1 is furthermore built up of a connecting device 6 of plastic material for an oscillating wiper arm 7. Said wiper arm 7 is finalized by an extension (without an adapter). Connecting device 6 consists of a first part 8 and a second part 9 detachably connected together. Said first part 8 is retained onto the wiperblade 2, whereas said second part 9 is positioned within said first part 8, that is between parallel, upright walls thereof. Further, said first part 8 comprises clamping members 10 that are integral therewith, which engage round

longitudinal sides of the strips 4 that face away from each other, as a result of which the connecting device 6 is firmly attached to the unit consisting of wiper blade 2 and strips 4. Said second part 9 has a U-shaped cross-section at the location of its connection to said first part 8. The oscillating wiper arm 7 is pivotally connected to the connecting device 6 about a pivot axis near a free end thereof, and that in the following manner.

10 With reference to figures 1 and 2, said second part 9 comprises two cylindrical protrusions 11 (only one is visible) extending outwards on either side of said second part 9, that is on each vertical side wall of its U-shaped, rectangular or square cross-section. These protrusions 11
15 pivotally engage in identically shaped cylindrical holes 12 (only one thereof is visible in figures 1 and 2) of said first part 8. Said protrusions 11 act as bearing surfaces at the location of a pivot axis in order to pivot the second part 9 (and the oscillating wiper arm 7 attached thereto)
20 about said pivot axis near a free end of said arm 7. The protrusions 11 are preferably in one piece with said second part 9. In the alternative, the protrusions 11 are part of a single pivot pin perpendicular to the connecting device 6.

25 Referring to figures 1, 2, 3 and 5, the second part 9 comprises a protrusion 13 extending downwardly from a top wall of said second part 9, while the oscillating arm 7 has an identically shaped hole 14 with a closed circumference at the location of its connection to said second part 9. Said
30 protrusion is hingeable between an inward position (figure 2 above and figure 5 above), wherein in a mounted position said protrusion 13 engages into said hole 14 provided in said oscillating arm 7 in order to retain said connecting

device 6 onto said oscillating arm 7, and an outward position (figure 2 below and figure 5 below), wherein in a dismounted position said protrusion 13 disengages from said hole 14 provided in said oscillating arm 7, allowing said
5 connecting device 6 to be released from said oscillating arm 3. As shown, said protrusion 13 is hingeable along two lateral hinges 15 located near an outer edge of said second part 9 and on opposite sides of said oscillating arm 7, upon activating a push button 16 on said second part 9 by hand in
10 the direction of arrow 17. More in particular, a part 18 of the top wall of the second part 9 is hingeable about said hinges 15, wherein the push button 16 is located at a top side of said part 18 near one end thereof, and wherein said protrusion 13 is located at a bottom side of said part 18
15 near an opposite end thereof. By activating or deactivating the push button 16, a hinge movement in the direction of arrows 19 is obtained. Said movement is a so-called seesaw movement. Said hinges 15 are invisible from the outside when the first and second parts 8,9 are interconnected.

20

The protrusion 13 on said second part 9 and the hole 14 in the oscillating arm 7 are meant for retaining the connecting device 6 onto the oscillating arm 7 and are therefore called "first retaining means". However, in case the first
25 retaining means would disfunction, for example when the protrusion 13 would not properly fit into the hole 14, the second part 9 and the first part 8 connected thereto would be able to move relative to the oscillating arm 7 in longitudinal direction of the wiper blade 2. In order to
30 avoid the wiper blade 2 from coming loose, with all negative consequences involved, second retaining means are provided for. Said second retaining means consist of an upwardly extending protrusion 20 on at least one of said parallel,

upright walls 21 of said first part 8 cooperating with a recess 22 in the oscillating arm 7 (figure 1). In other words, said protrusion 20 engages into said correspondingly shaped recess 22 provided on a longitudinal (exterior) side 5 23 of the oscillating arm 7. Said protrusion 20 may also be called a cam.

For mounting or dismounting the connecting device 6 onto or from the oscillating arm 7, the second part 9 and thus the 10 free end of the oscillating arm 7 connected thereto is pivoted relative to the first part 8 (figure 7). While carrying out the pivot movement the protrusion or cam 20 is no longer in line with the recess 22 and cannot mutually cooperate any longer, so that the second part 9 and the 15 first part 8 attached thereto can be released from the oscillating arm 7. This can, of course, only be done when also the protrusion 13 in all embodiments is released from the hole 14.

20 It is noted that one of said walls 21 is higher than the other wall 21, so that an extension 24 is obtained. During wiping rain water is kept onto the connecting device 6 due to said higher wall 21, so that said rain water is not allowed to splash onto the windscreen to be wiped.

25

The invention is not restricted to the variants shown in the drawing, but it also extends to other embodiments that fall within the scope of the appended claims.

30

CLAIMS

1. A windscreen wiper device (1) comprising an elastic,
elongated carrier element, as well as an elongated wiper
5 blade (2) of a flexible material, which can be placed in
abutment with a windscreen to be wiped, which wiper
blade (2) includes at least one groove (3), in which
groove (3) a longitudinal strip (4) of the carrier
element is disposed, wherein ends of said longitudinal
10 strip (4) are connected by a respective connecting
piece, which windscreen wiper device (1) comprises a
connecting device (6) for an oscillating arm (7),
wherein said oscillating arm (7) can be pivotally
connected to said connecting device (6) about a pivot
15 axis near one end, **characterized in that** said connecting
device (6) comprises at least two parts (8, 9) provided
with protrusion/hole means arranged for detachably
connecting said parts (8, 9) together through a snapping
operation, wherein the first part (8) is retained onto
20 the wiper blade (2) and wherein the second part (9)
comprises a channel arranged for inserting said
oscillating arm (7) therein, wherein said windscreen
wiper device (1) is provided with retaining means
arranged for retaining said connecting device (6) onto
25 said oscillating arm (7), wherein said retaining means
comprises at least one downwardly extending protrusion
(13) on the second part (9), wherein said protrusion
(13) is movable between an inward position, wherein in
mounted position said protrusion (13) engages into a
30 correspondingly shaped hole (14) provided in said
oscillating arm (7) and said connecting device (6) is
retained onto said oscillating arm (7), and an outward
position, wherein in dismounted position said protrusion

(13) disengages from said hole (14) provided in said oscillating arm (7) and said connecting device (6) is released from said oscillating arm (7).

- 5 2. A windscreen wiper device (1) according to claim 1,
wherein said protrusion (13) is hingeable between said
inward position and said outward position.
- 10 3. A windscreen wiper device (1) according to claim 2,
wherein said protrusion (13) is hingeable along hinges
(15) of said second part (9) located on opposite sides
of said oscillating arm (7) in mounted position thereof.
- 15 4. A windscreen wiper device (1) according to claim 2 or 3,
wherein said protrusion (13) is hingeable from said
inward position into said outward position upon
activating a push button (16) on said second part (9).
- 20 5. A windscreen wiper device (1) according to any of the
preceding claims 1 through 4, wherein said retaining
means form first retaining means, and wherein said
windscreen wiper device (1) is further provided with
second retaining means arranged for retaining said
25 connecting device (6) onto said oscillating arm (7),
wherein said second retaining means comprises at least
one protrusion (20) provided on the first part (8)
arranged to engage the oscillating arm (7).
- 30 6. A windscreen wiper device (1) according to claim 5,
wherein said protrusion (20) on the first part (8) is
arranged to engage into a recess (22) provided on a
longitudinal side (23) of the oscillating arm (7).

7. A windscreen wiper device (1) according to claim 5 or 6, wherein said protrusion (20) on the first part (8) is located near an insertion opening of said channel arranged for inserting said oscillating arm (7) therein.
- 5
8. A windscreen wiper device (1) according to any of the preceding claims 1 through 7, wherein the second part (9) is positioned within said first part (8), wherein said second part (9) has vertical side walls, wherein
- 10 said first part (8) is provided with opposite abutting surfaces (21) for abutting against the vertical side walls of the second part (9), and wherein a protrusion (11) at the location of said pivot axis extends
- 15 laterally outwardly from each side wall of the second part (9) into a hole (12) provided on an abutting surface (21) abutting against a respective side wall.
9. A windscreen wiper device (1) according to claim 8, wherein one of said abutting surfaces (21) of said first
- 20 part (8) has a larger height than the other abutting surface of said first part (8).
10. A wiper arrangement of a windscreen wiper device (1) according to any of the preceding claims 1 through 9 and
- 25 an oscillating arm (7) connected thereto.
11. A wiper arrangement according to claim 10 provided with a windscreen wiper device according to claim 5, 6 or 7, wherein for mounting or dismounting said connecting
- 30 device (6) onto or from said oscillating arm (7), the second part (9) of said windscreen wiper device (1) and the free end of said oscillating arm (7) connected thereto are arranged to be pivoted relative to said

first part (8) of said windscreen wiper device (1) in order to disengage the protrusion (20) on the first part (8) from the recess (22) on the longitudinal side (23) of said oscillating arm (7).

5

12. Method for manufacturing a windscreen wiper device (1) comprising an elastic, elongated carrier element, as well as an elongated wiper blade (2) of a flexible material, which can be placed in abutment with a
10 windscreen to be wiped, which wiper blade (2) includes at least one groove (3), in which groove (3) a longitudinal strip (4) of the carrier element is disposed, wherein ends of said longitudinal strip (4) are connected by a respective connecting piece, which
15 windscreen wiper device (1) comprises a connecting device (6) for an oscillating arm (7), wherein said oscillating arm (7) can be pivotally connected to said connecting device (6) about a pivot axis near one end, **characterized in that** said connecting device (6) is made
20 of at least two parts (8, 9) provided with protrusion/hole means arranged for detachably connecting said parts (8, 9) together through a snapping operation, wherein the first part (8) is retained onto the wiper blade (2) and wherein the second part (9) is provided
25 with a channel arranged for inserting said oscillating arm (7) therein, wherein said windscreen wiper device (1) is provided with retaining means arranged for retaining said connecting device (6) onto said oscillating arm (7), wherein said retaining means is
30 provided with at least one downwardly extending protrusion (13) on the second part (9), wherein said protrusion (13) is movable between an inward position, wherein in mounted position said protrusion (13) engages

into a correspondingly shaped hole (14) provided in said oscillating arm (7) and said connecting device (6) is retained onto said oscillating arm (7), and an outward position, wherein in dismounted position said protrusion
5 (13) disengages from said hole (14) provided in said oscillating arm (7) and said connecting device (6) is released from said oscillating arm (7).

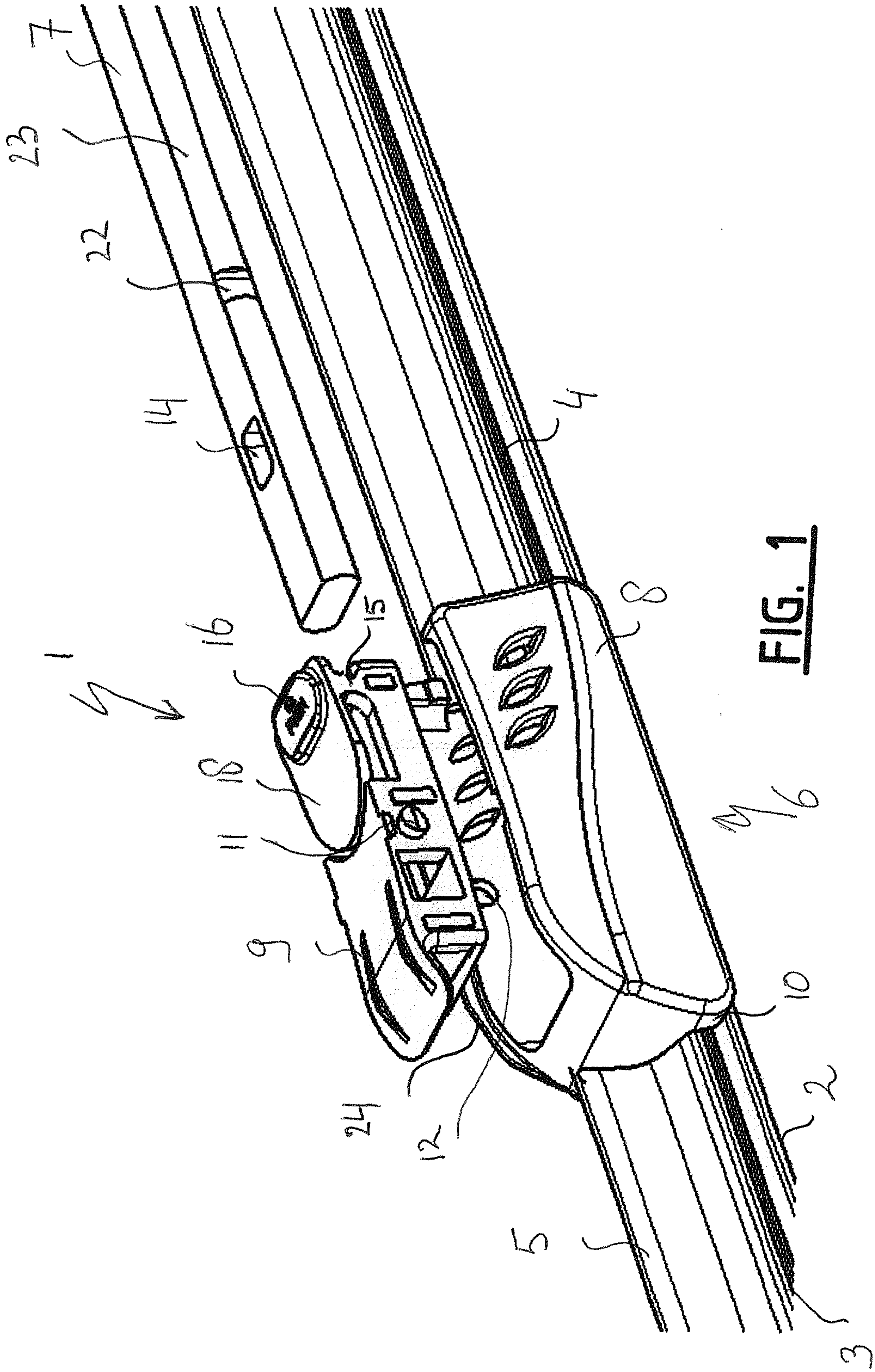

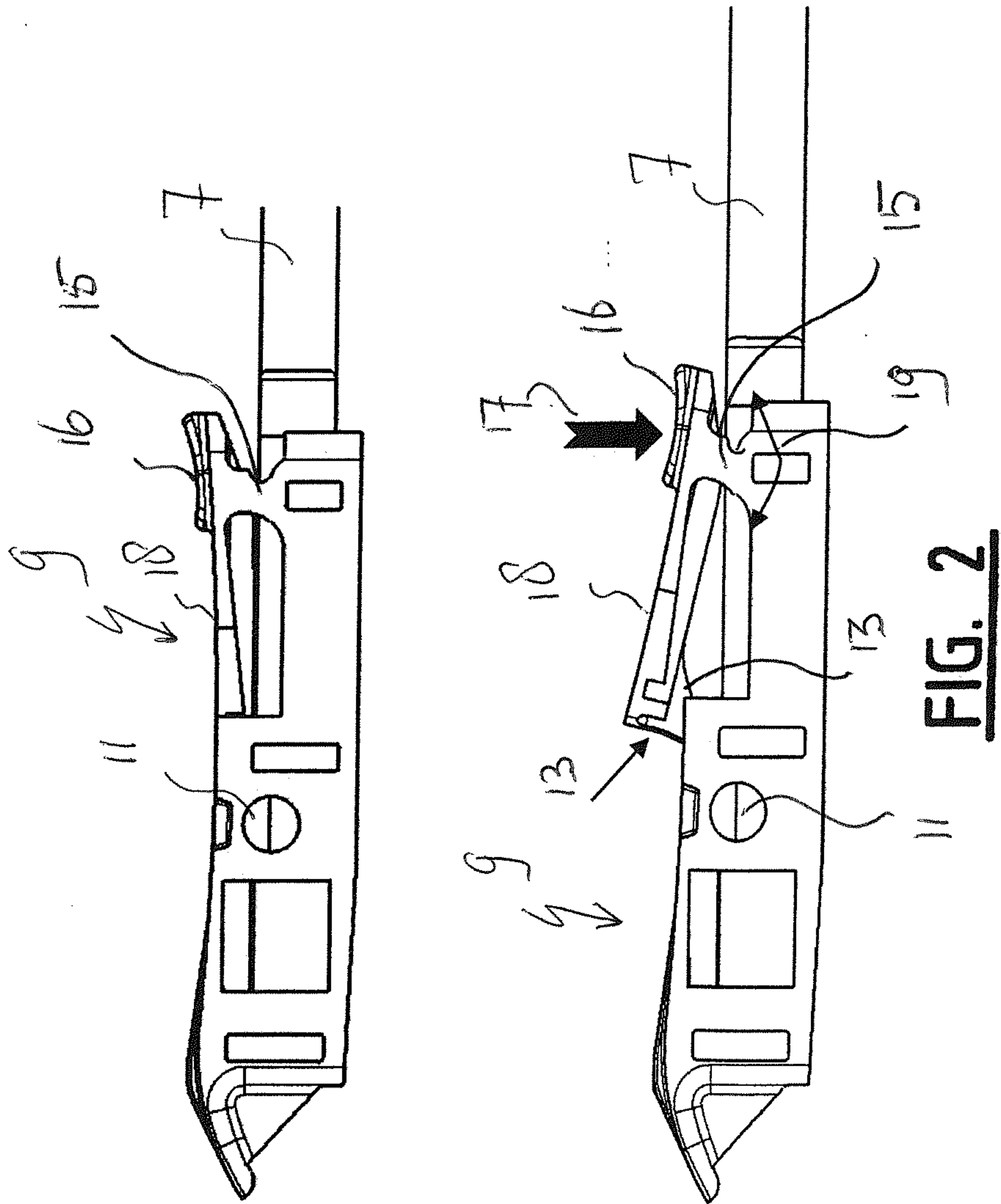
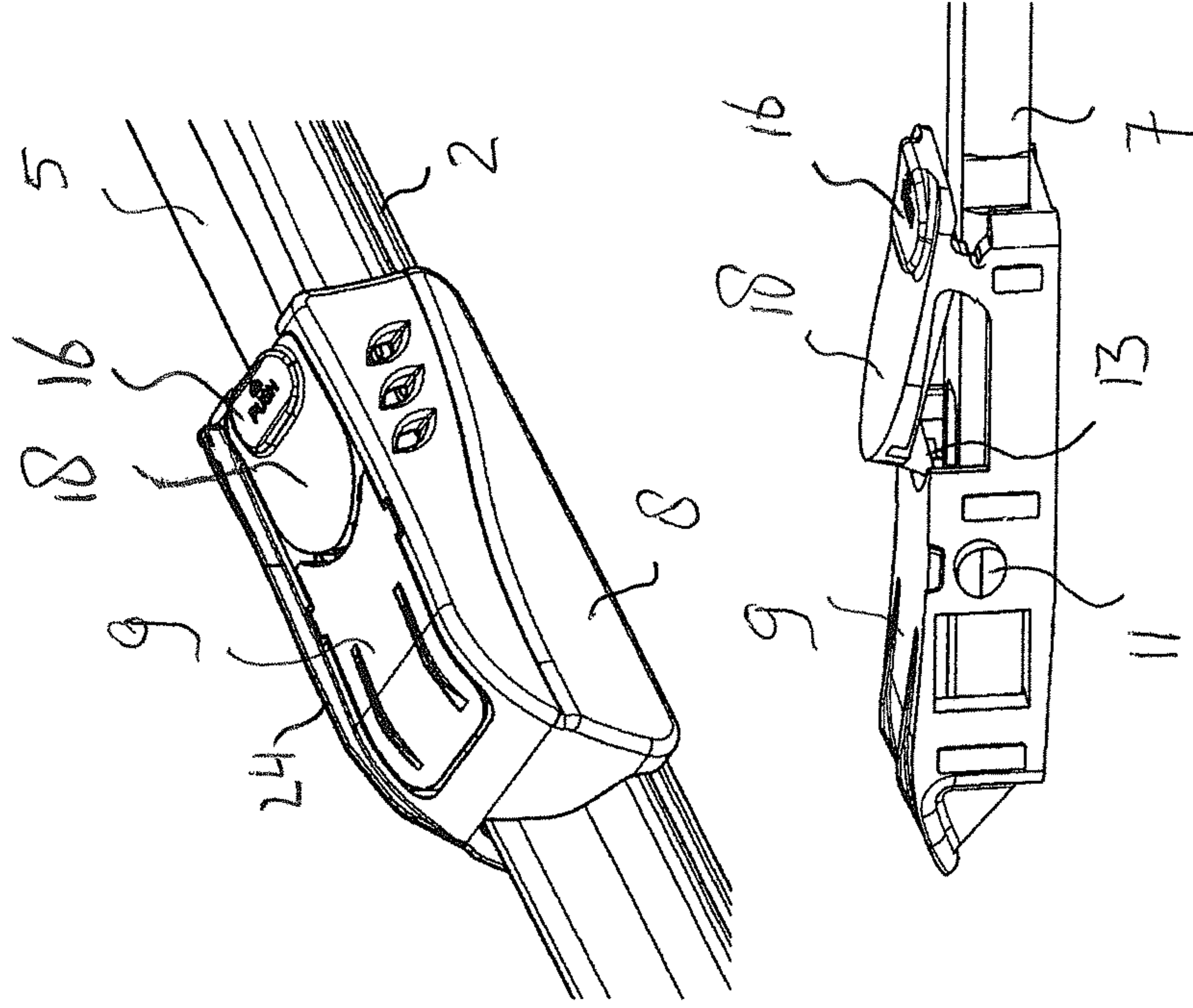

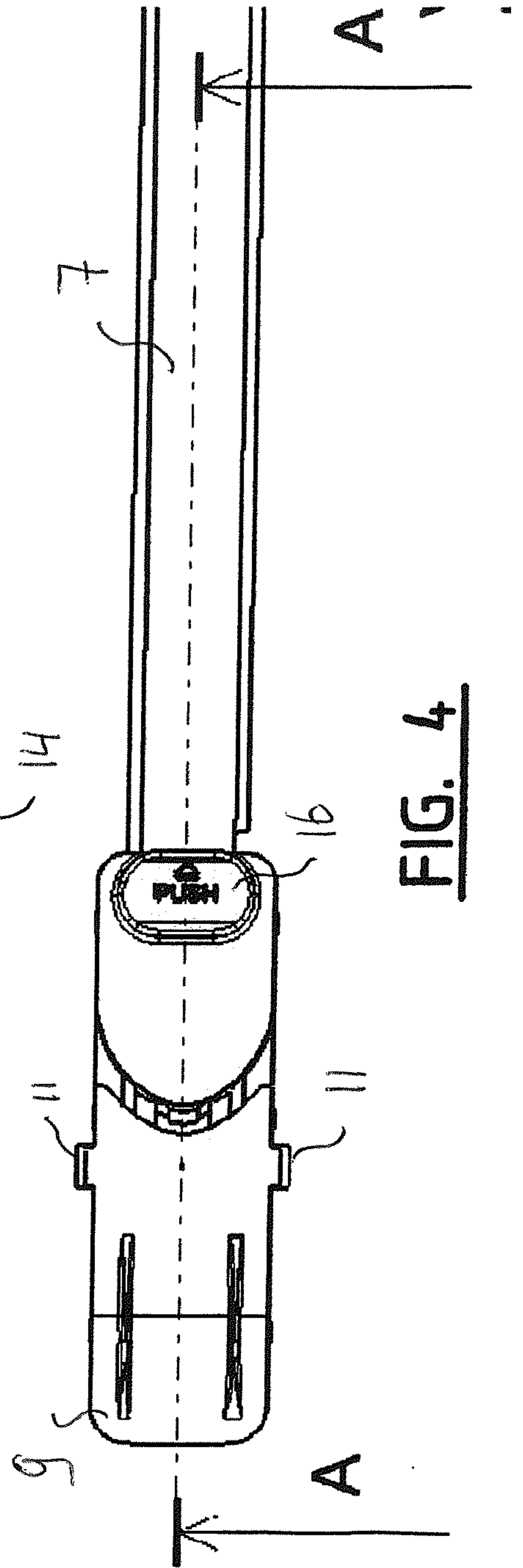
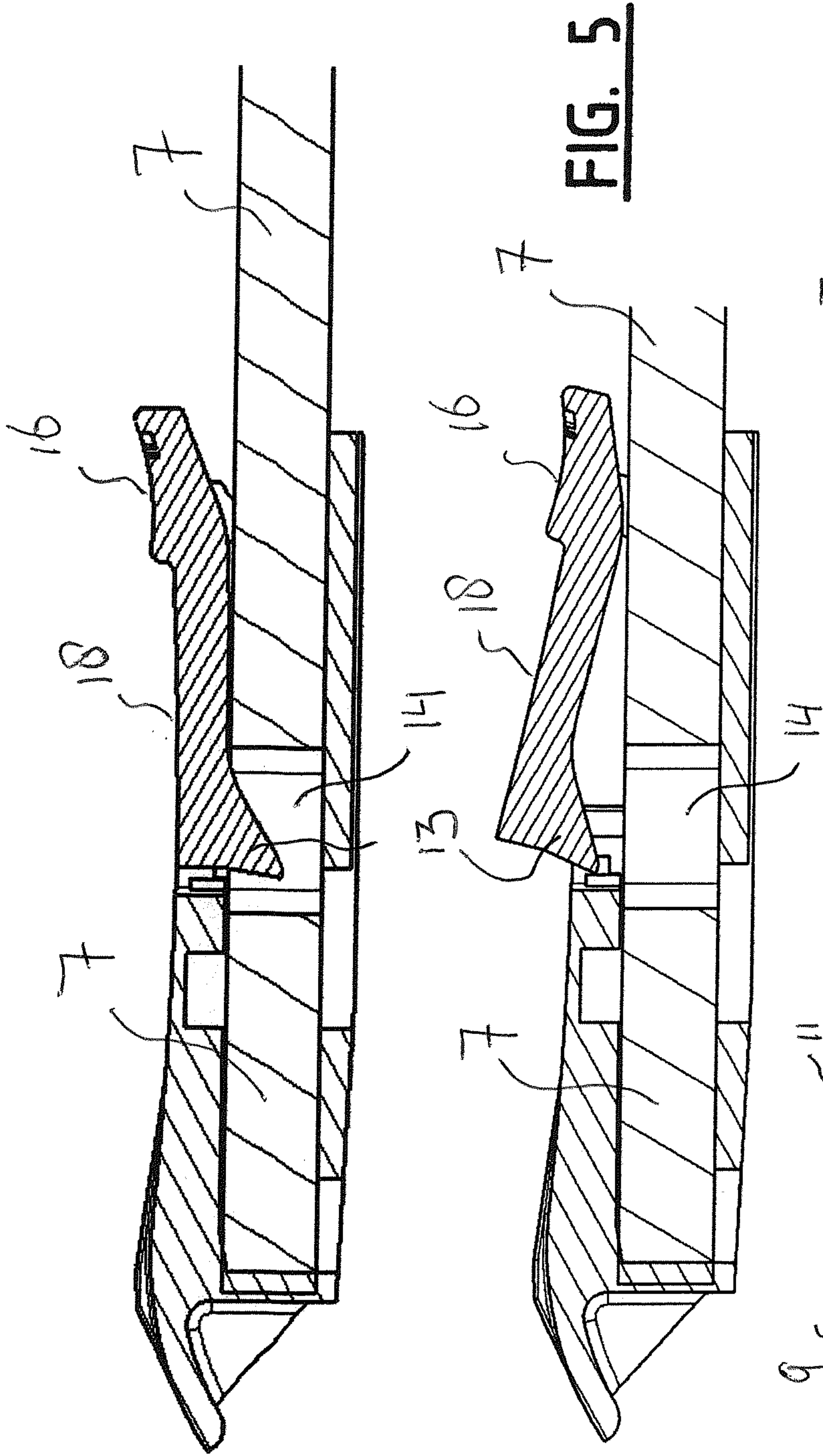

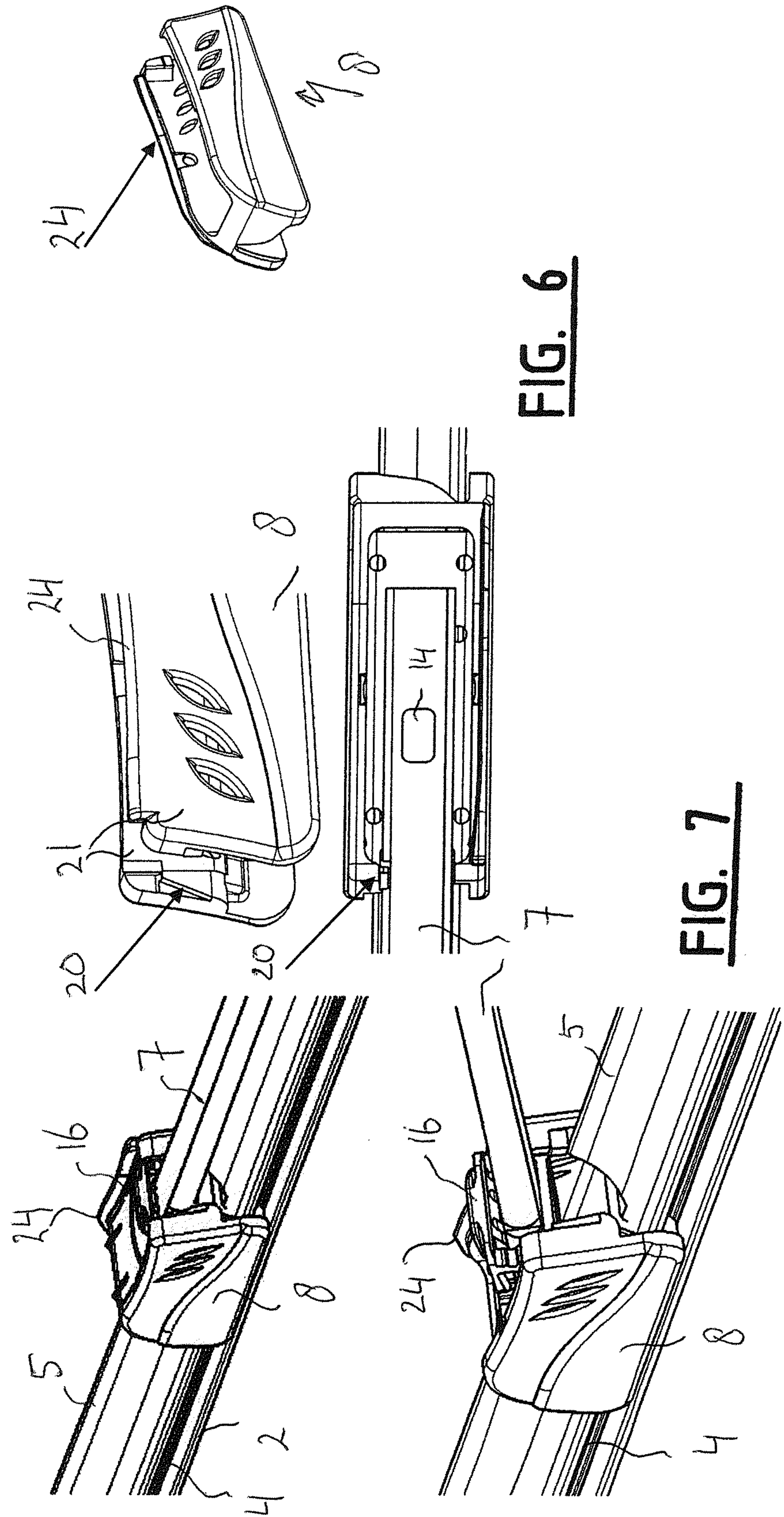

FIG. 6

FIG. 7

