

[72] Inventors **Frank S. Payerle**
Akron;
Richard M. Moser, Stow, both of, Ohio

[21] Appl. No. **847,661**

[22] Filed **Aug. 5, 1969**

[45] Patented **June 15, 1971**

[73] Assignee **North American Rockwell Corporation**
Pittsburgh, Pa.

3,323,386 6/1967 Musick et al. 200/6 (A) (X)
 3,392,596 7/1968 Morris 74/471

Primary Examiner—Robert K. Schaefer
Assistant Examiner—William J. Smith
Attorneys—John R. Bronaugh, Floyd S. Levison and E. Dennis O'Connor

[54] **SINGLE LEVER CONTROL**
7 Claims, 9 Drawing Figs.

[52] U.S. Cl. **200/6 A,**
 74/471 XY, 200/153 K

[51] Int. Cl. **H01h 21/24**

[50] Field of Search **200/6 A,**
 153.10; 74/471

[56] **References Cited**

UNITED STATES PATENTS		
2,539,120	1/1951	Courtot 97/471
2,553,280	5/1951	Rossire 74/471
2,984,720	5/1961	Fisher 200/6 (A) (X)
3,266,523	8/1966	Stevens 74/471(X)
3,277,248	10/1966	Melvin 200/6 A
3,295,386	1/1967	Menefee et al. 74/471
3,296,882	1/1967	Durand 200/6 (A) (X)

ABSTRACT: A single lever control unit for regulating a plurality of remote, servient mechanisms. At least two motion transmitting mechanisms in the nature of push-pull control cables are individually, and selectively, operated by a single control lever pivotally, and rotatably, mounted in the unit to regulate at least two, remote, servient mechanisms. The control unit has first and second throw arms that are oriented transversely with respect to each other and so mounted that each is selectively rotatable about the axis of the other by manipulation of the lever. The core of one push-pull cable is attached to the first throw arm for actuation by rotation of the first throw arm about the axis of the second throw arm, and the core of another push-pull cable is attached to the second throw arm for actuation by rotation of the second throw arm about the axis of the first throw arm. A plurality of switch means are mounted in the unit to be actuated in response to selected rotations of the throw arms to regulate a third, remote, servient mechanism.

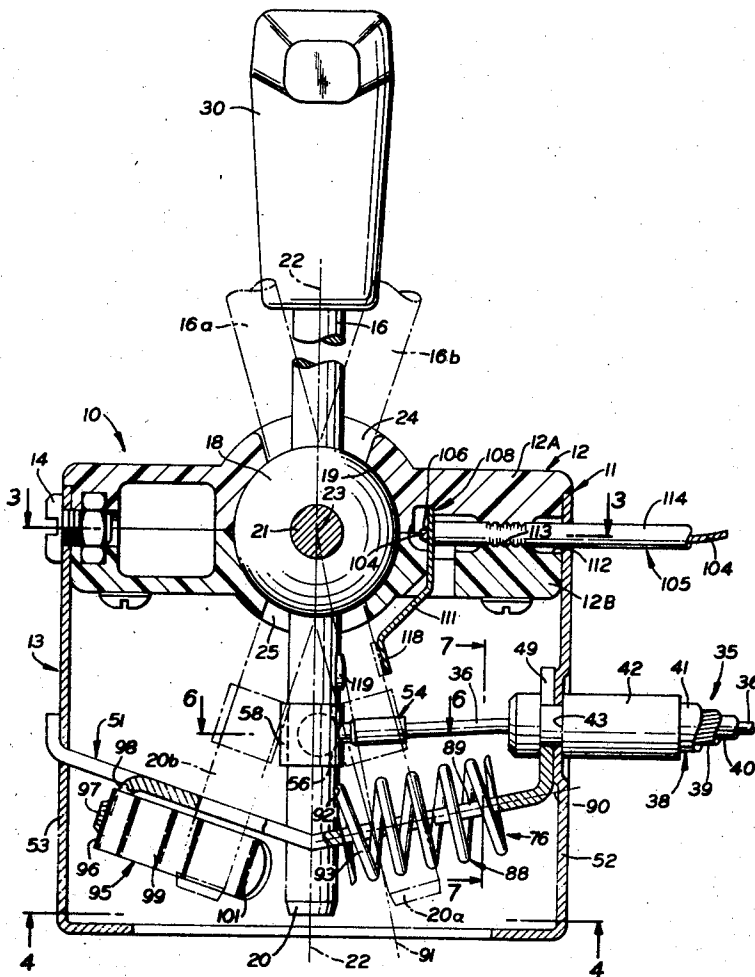

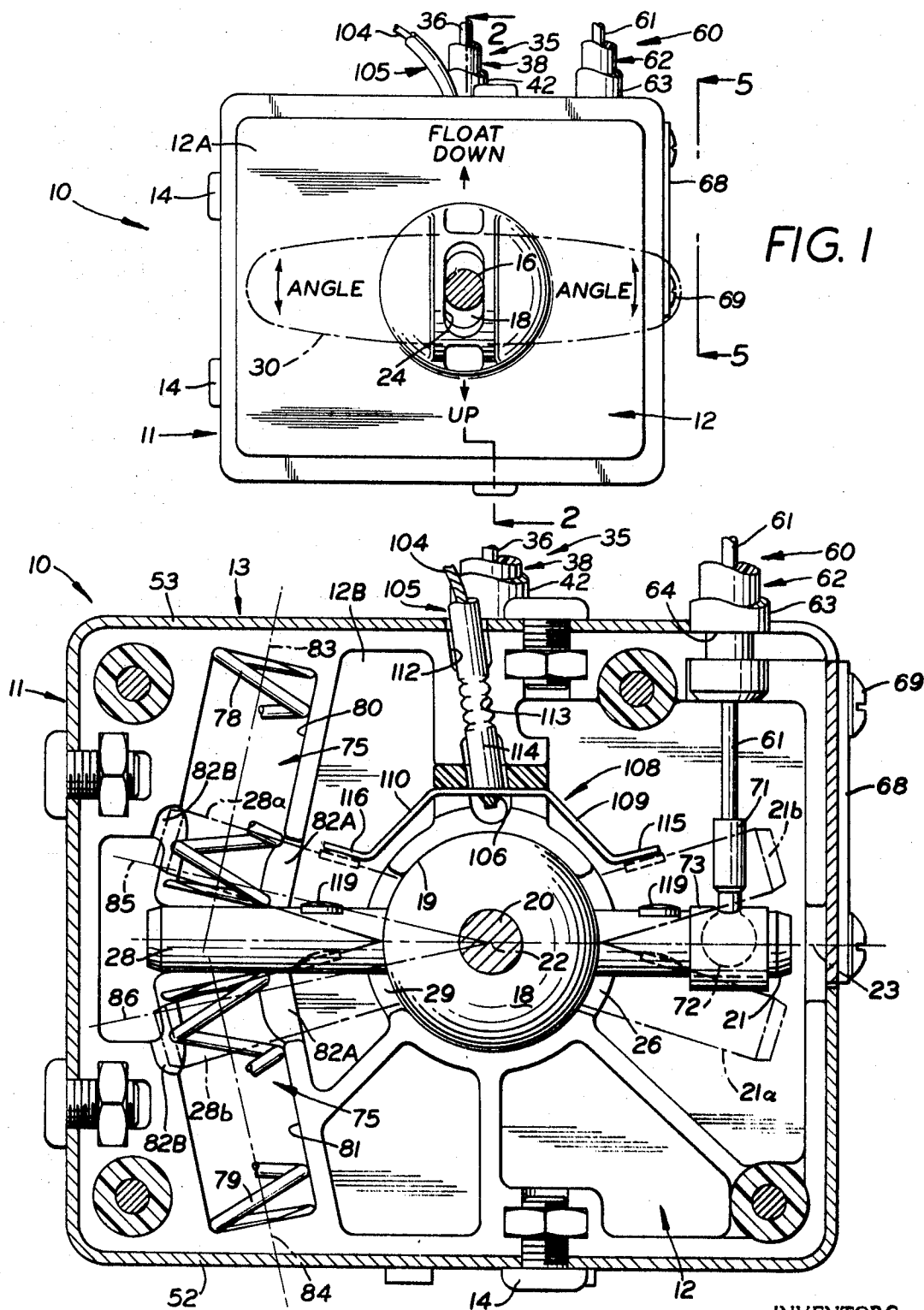

FIG. 1

FIG. 3

INVENTORS
FRANK S. PAYERLE
RICHARD M. MOSER
BY *Hamilton, Cook,
Reamer & Kennen*
ATTORNEYS

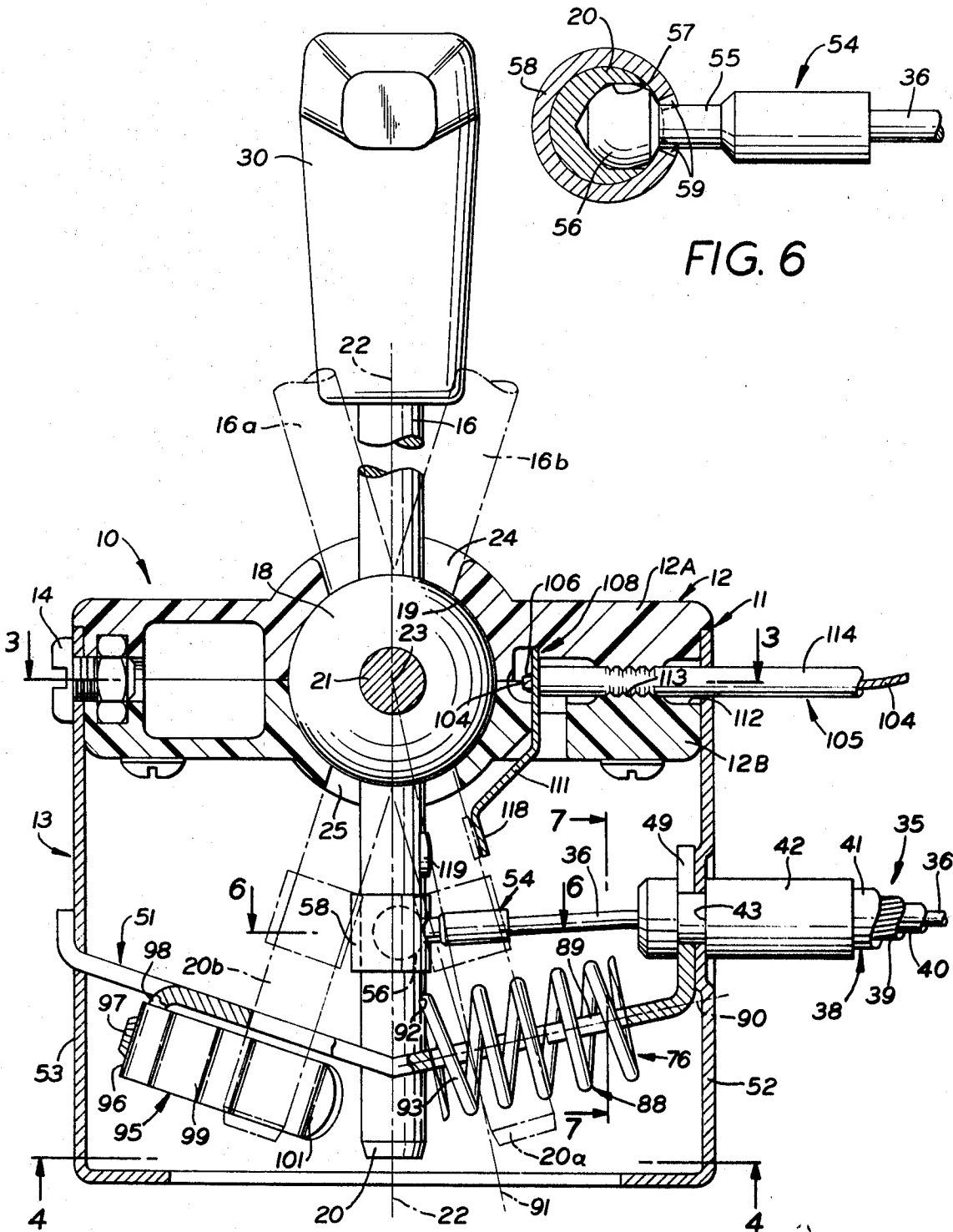

FIG. 2

FIG. 6

INVENTORS
FRANK S. PAYERLE
RICHARD M. MOSER
BY *Hamilton, Cook,*
Renner & Kenner
ATTORNEYS

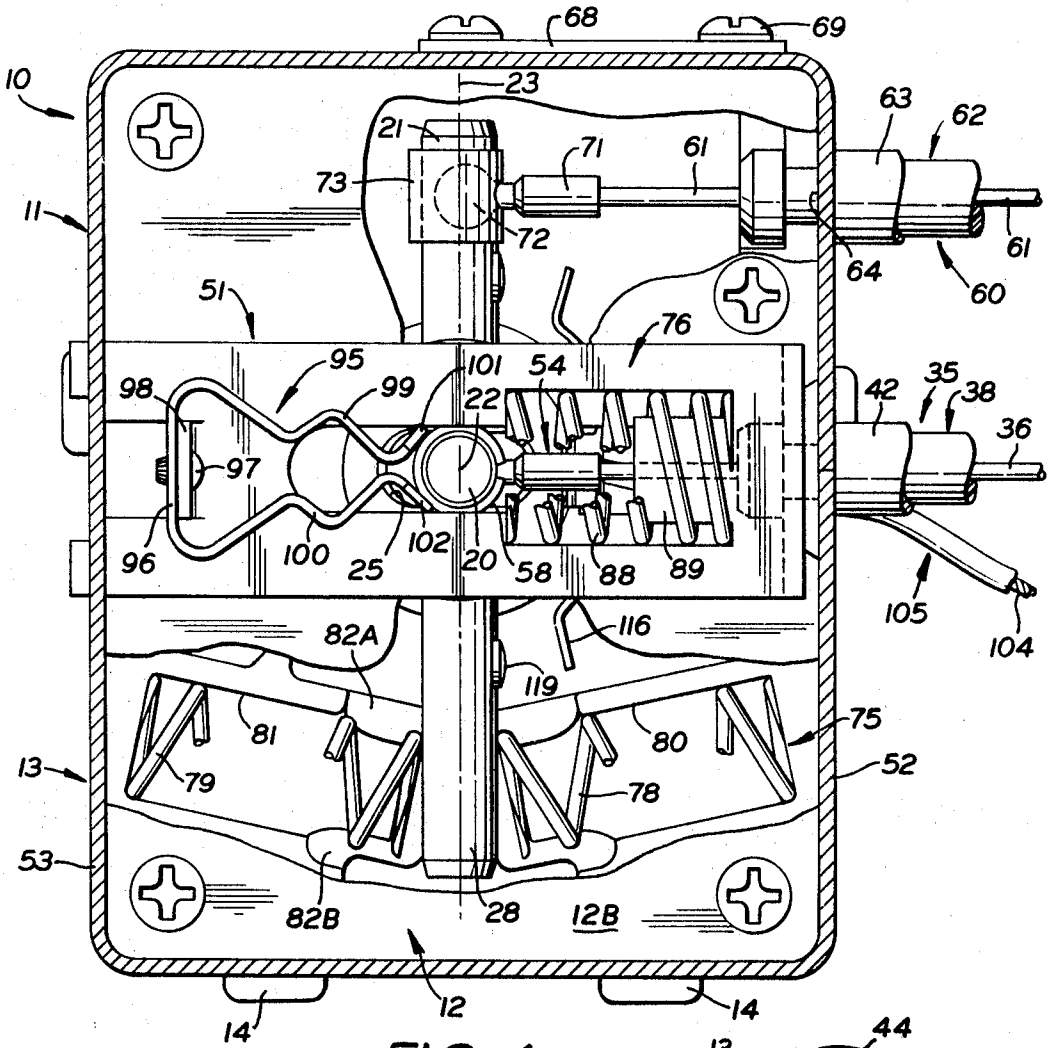

FIG. 4

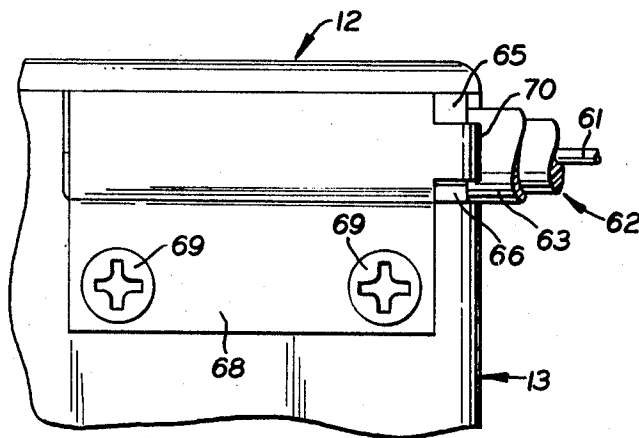

FIG. 5

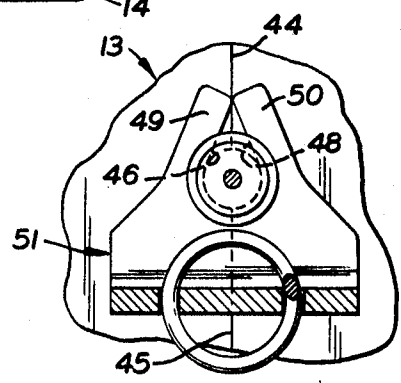
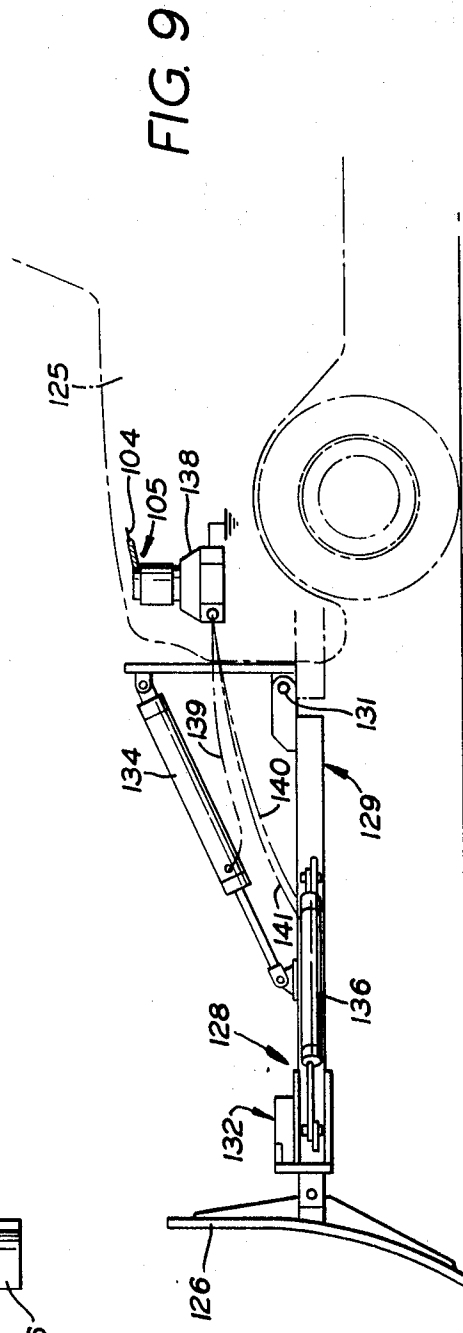
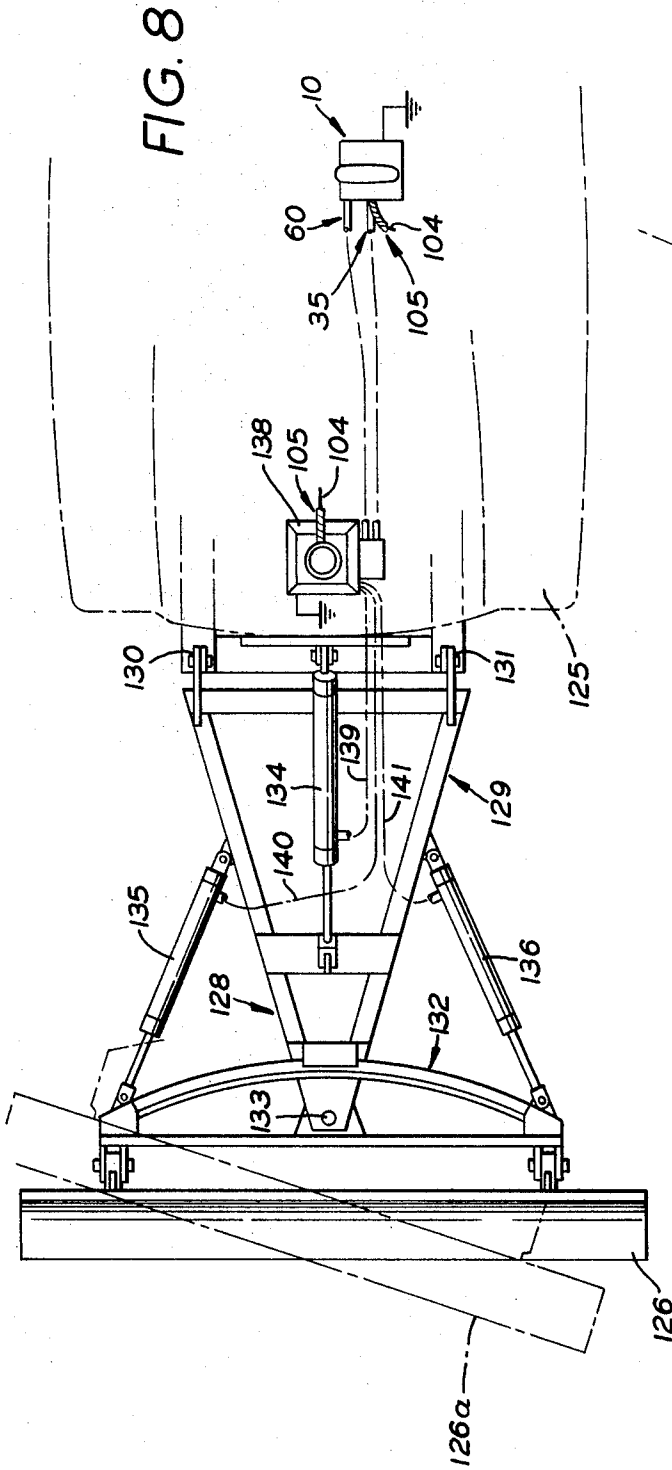

FIG. 7

INVENTORS
FRANK S. PAYERLE
RICHARD M. MOSER
BY *Hamilton, Cook,*
Rennet Kerner
ATTORNEYS



INVENTORS
FRANK S. PAYERLE
RICHARD M. MOSER
BY *Hamilton, Cook,
Renner & Keener*
ATTORNEYS

SINGLE LEVER CONTROL

BACKGROUND OF THE INVENTION

There are many situations which require individual regulation of two, remote, servient mechanical devices and a remote, servient electrical device. Primitively, such regulation can be effected by separate mechanical controls individually connected to the remote, servient, mechanical devices and a further separate electrical control connected to the remote, electrical device.

In installations where actuation of the electrical device is required simultaneously with selected actuation of the individual mechanical devices, the prior art employs a plurality of electrical controls in conjunction with an individual control for each servient mechanical device, the individual electrical controls being interlinked by complex wiring arrangements to accomplish the desired simultaneous actuation of the remote electrical device.

The inconvenience of requiring multiple mechanical controls can be readily appreciated, for example, from an understanding of the controls heretofore utilized to regulate the vertical and rotative position of a blade such as an earth scraper or a snowplow. Both vertical and rotative positioning of such blades may be accomplished by hydraulic power cylinders, the cylinders being selectively supplied with pressurized fluid and being selectively permitted to release retained fluid through well-known valve means. Such valve means can be effectively regulated by mechanical motion transmitting means of the type commonly referred to as push-pull control cables. When one control cable is used to regulate the valve means that controls raising and lowering of the blade, and a second control cable is used to regulate the valve means that controls horizontal rotation of the blade the prior art has, for the most part, heretofore utilized individual control means for each cable.

In addition, it is often desirable to have the pump which provides the pressurized fluid operate only while the position of the blade is being adjusted. This, too, has, for the most part, heretofore necessitated the inclusion of a complex, interconnected electrical control means between the individual mechanical control means.

In my copending application, Ser. No. 742,618, filed July 5, 1968, one concept is taught whereby actuation of three such remote mechanisms can be effected by a single control lever.

SUMMARY OF THE INVENTION

It is therefore an object of the present invention to provide a control means embodying a new and novel concept whereby a single lever can be used to regulate at least two motion transmitting means individually.

It is another object of the present invention to provide a single lever control unit, as above, that will operate an electrical control concurrently with selected regulation of the individual motion transmitting means.

It is a further object of the present invention to provide a single lever control unit, as above, that is relatively uncomplicated and inexpensive to manufacture and maintain and, at the same time, capable of providing a long and useful life under adverse working conditions.

These and other objects, as well as the advantages thereof over existing and prior art forms, will become apparent in view of the following detailed description of the attached drawings and are accomplished by means hereinafter described and claimed.

In general, a single lever control unit embodying the concept of the present invention will actuate at least two motion transmitting means. First and second throw arms are conjoined and mounted in a housing for selective movement in response to manipulation of a control lever. A first motion transmitting means is connected to the first throw arm for actuation in response to movement of that throw arm, and a

second motion transmitting means is connected to the second throw arm for actuation in response to movement of that throw arm.

Additionally, a plurality of switch means may also be mounted in the housing for actuation in response to selected movements of the throw arms.

One preferred form of the present invention is shown by way of example in the accompanying drawings and described in detail without attempting to show all of the various forms and modifications in which the invention might be embodied; the invention being measured by the appended claims and not by the details of the specification.

DESCRIPTION OF THE DRAWINGS

FIG. 1 is a top plan, partly in section, of a single lever control unit embodying the concept of the present invention;

FIG. 2 is an enlarged vertical cross section taken substantially on line 2-2 of FIG. 1;

FIG. 3 is a horizontal cross section taken substantially on line 3-3 of FIG. 2 and rotated 90° to orient fully with FIG. 1 which appears on the same sheet of drawings;

FIG. 4 is a horizontal cross section taken substantially on line 4-4 of FIG. 2;

FIG. 5 is an enlarged, partial, side elevation taken substantially on line 5-5 of FIG. 1;

FIG. 6 is a further enlarged, horizontal cross section taken substantially on line 6-6 of FIG. 2;

FIG. 7 is a vertical cross section taken substantially on line 7-7 of FIG. 2;

FIG. 8 is a schematic top plan of a snowplow mount operable by a control unit embodying the concept of the present invention; and,

FIG. 9 is a schematic side elevation of the snowplow mount depicted in FIG. 8.

DESCRIPTION OF THE PREFERRED EMBODIMENT

Referring more particularly to the drawings, a control embodying the concept of the present invention is indicated generally by the numeral 10. The frame 11 of control 10 comprises a housing assembly 12 at the upper portion thereof with a skirt portion 13 secured thereto, as by a plurality of bolts 14. The lower perimeter of the skirt portion 13 may rest on a floorboard (not shown) or the like, when the control 10 is in operative position.

A single control lever 16 extends upwardly from the frame 11. Specifically, the control lever 16 is secured to, and extends outwardly of, a mounting ball 18 universally pivoted in a socket 19 formed between the mating halves 12A and 12B of the housing assembly 12.

First and second throw arms 20 and 21, respectively, also extend outwardly of the mounting ball 18. The axis 22 of the first throw arm 20 (FIG. 2) preferably comprises a linear extension of the axis of the control lever 16, and the axis 23 of the second throw arm 21 (FIG. 3 and 4) preferably lies at right angles to the axis 22 of the first throw arm 20. This transverse orientation of the throw arms with respect to each other permits an absolute independence to the movement of the throw arms, as is generally preferable in the environment with which the operation of the subject control 10 will hereinafter be explained.

In any event, a series of guide slots pierce the socket 19 to delineate the ranges, and the directions, through which the control lever 16 and the two throw arms 20 and 21 can be displaced.

The control lever 16 extends through a guide slot 24 in the upper half 12A of the housing assembly 12, and the first throw arm 20 extends through a guide slot 25 in the lower half 12B of the housing assembly. The guide slots 24 and 25, though opposed, lie in a plane oriented transversely to the axis 23 of the second throw arm 21 when the second throw arm is in its neutral position, as depicted by the solid line representation in FIGS. 3 and 4 in order to permit the first arm 20 to rotate

about the axis 23 in response to rotation of the control lever 16 about that same axis.

The throw arm 21 extends through a slot 26 provided at the juncture of the housing halves 12A and 12B. A centering arm 28 extends outwardly of the mounting ball 18 in position to the throw arm 21 and preferably along the axis thereof. The centering arm 28 extends through a guide slot 29 also provided at the juncture of the housing halves 12A and 12B. The guide slots 26 and 29, though opposed, lie in a plane oriented transversely to the axis 22 of the first throw arm 20 when the first throw arm is in its neutral position (FIG. 2) in order to permit the second throw arm 21, and the centering arm 28, to rotate about axis 22 in response to rotation of the control lever 16 about its own axis 22.

In order to facilitate the rotation of control lever 16 about its own axis 22 a T-shaped handle 30 may be nonrotatably secured thereto.

The first motion transmitting means, such as push-pull cable 35, is operatively attached to the first throw arm 20. The push-pull cable 35, as best seen in FIG. 2, may be of any conventional construction having a core 36 that slidably reciprocates within a casing 38 to transmit mechanical motion by the application of either tensile or compressive forces to the core 36. In the exemplary construction depicted, the casing 38 is formed of a plurality of casing wires 39 laid contiguously, in the form of a long pitched helical coil, about the radially outer surface of an inner, flexible plastic tube 40 which extends the full length of the casing 38. An outer cover 41 encases the coil of wires 39 up to within a short distance from the ends thereof.

A fitting 42 is positioned over the end of the cable casing 38 and is cold swaged, or otherwise suitably connected, onto and exposed end portion (not shown) of the cylindrical grouping of wires 39. A plurality of annular ribs (also not shown) may be provided within the fitting 42 which, when crimped onto the cover 41, effect a seal between the end fitting 42 and the cover 41.

A retaining groove 43 is provided on the exterior of the fitting 42 for engagement with the skirt portion 13 of the frame 11.

In order to facilitate assembly of the control 10, the skirt portion 13 may be folded from a single sheet of metal, the opposed edges 44 and 45 of which, as best seen in FIG. 7, are thereby brought into juxtaposition. Opposed, semiannular notches 46 and 48 are recessed into the respective edges 44 and 45 and are received within and embrace the retaining groove 43. Spaced ears 49 and 50 on one end of the multipurpose bridge 51 that stands between the front and back walls 52 and 53, respectively, of the skirt portion 13 are also received within the retaining groove 43 and bent to embrace the fitting 42. As best shown in FIG. 2, the thickness of the opposed edges 44 and 45—i.e., the front wall 52—combined with the thickness of the individual ears 49 and 50 substantially equals the axial dimension of the retaining groove 43. In this way the interaction of the notches 46 and 48, the ears 49 and 50 and the retaining groove 43 fully secures the cable casing 38 to the control 10.

The core 36, which is preferably of the solid wire variety, extends outwardly through the end fitting 42 to the throw arm 20. A terminal fitting 54, as best seen in FIG. 6, is secured, as by staking, onto the core 36. The stem portion 55 of the fitting 54 projects outwardly in substantial alignment with core 36 and presents a ball 56 that is received within a cavity 57 in the throw arm 20. A generally C-shaped spring clip 58 embraces the throw arm 20, and the opposed ends of the clip 58 are notched, as at 59, to conform concentrically with stem 55 and thereby retain the ball 56 within the cavity 57 and yet permit it to swivel freely therein to accommodate the rotative motion of the throw arm 20—about either its own axis 22 or axis 23—with the least possible flexure being imposed upon core 36.

Another motion transmitting means, such as push-pull cable 60, is operatively attached to the second throw arm 21. The control cable 60, like control cable 35, may be of any conventional construction having a core 61 slidably received within a

casing 62. An end fitting 63 is secured to casing 62, and it, too, may have an annular retaining groove 64 in the exterior surface thereof for engagement with opposed locating flanges 65 and 66 presented from the opposed halves 12A and 12B in the housing assembly 12. A retaining plate 68—which may be secured to the skirt portion 13 by a plurality of self-tapping screws 69—presents an inwardly directed leg portion 70 that engages the end fitting 63 to retain it in firm engagement with the locating flanges 65 and 66 and thus secure the cable casing 62 to the housing assembly 12 of the control 10.

The core 61, which is also preferably of the solid wire variety, extends outwardly through the end fitting 63 to the second throw arm 21. A terminal fitting 71 secured to the core 61 also presents a ball 72 received within a cavity (not shown, but which may be similar to cavity 57 in arm 20) in the throw arm 21 and retained therein by a spring clip 73 that permits the ball 72 to swivel freely and thereby reduce the flexure imposed upon core 61.

At this point it should be appreciated that the application of a swinging movement to the control lever 16 about axis 23 will swing the first throw arm 20 to translate the core 36 with respect to the casing 38 of cable 35. Because the guide slots 24 and 25 delineate a fixed plane through which the control lever 16 and throw arm 20 can be swung, in order to assure that only the first motion transmitting means will be actuated it is preferable to provide a detent means 75 by which the second throw arm 21 will normally be retained in its neutral position—i.e., oriented transversely to the plane of the guide slots 24 and 25, as shown by the solid line representation in FIGS. 3 and 4.

Similarly, it should also be appreciated that the application of a rotation of movement to the control lever 16 about its own axis 22 will swing the second throw arm 21 to translate the core 61 with respect to the casing 62 of cable 60. And, because the guide slots 26 and 29 delineate a fixed plane through which the second throw arm 21 can be swung, in order to assure that only the second motion transmitting means will be actuated it is preferable to provide a detent means 76 by which the first throw arm 20 will normally be urged toward its neutral position—i.e., oriented transversely to the plane of guide slots 26 and 29, as shown by the solid line representation in FIG. 2—from at least one direction.

As best seen in FIGS. 3 and 4, detent means 75 may comprise a pair of detent springs 78 and 79 captured within cylindrical cavities 80 and 81 recessed into the housing assembly 12. The two cavities are generally opposed, and the two halves 12A and 12B in the housing 12 are relieved, as at 82A and 82B, to accommodate the swinging movement of the centering arm 28 into and between the generally opposed cavities 80 and 81.

In the embodiment depicted in the drawings, actuation of the remote mechanism controlled by the second motion transmitting means requires approximately a 38° swing of the second throw arm 21 about axis 22—i.e., approximately 19° on each side of the neutral position. As such, the relieved portions 82A and 82B in the housing assembly 12 must be of a dimension sufficient to accommodate a concomitant swing of the centering arm 28—the extreme ranges being represented by the chain line positions 28a and 28b in FIG. 3.

Because the centering arm 28 swings through an arc and because the axes of the detent springs 78 and 79 remain fixed, it has been found highly desirable to incline the axes 83 and 84 of the detent springs 78 and 79, respectively, with respect to each other and yet retain them within the plane through which the centering arm 28 swings. Each detent spring engages the centering arm only on one side of the neutral position represented in FIG. 3. Accordingly, each spring is inclined such that its axis will lie normal to the centering arm 28 at only one point during its swing, and it has been found that if that point is located at approximately two-thirds of the angular range between neutral and full swing, the spring operates far more effectively. As such, in the embodiment depicted the axes 83 and 84 of springs 78 and 79 are, respectively, perpen-

dicular to reference lines 85 and 86 located approximately 12° on either side of the neutral position.

The detent means 76, as best seen in FIGS. 2 and 4, comprises a coil spring 88 captured within the multipurpose bridge 51 by a tab portion 89 that extends axially interiorly thereof. The axial extend to which the tab portion 89 can penetrate the spring 88 is limited by the axial dimension of the spring itself and the range through which the spring must compress to allow the rotation of the throw arm 20 necessary to displace the core 36 of cable 35 the required amount. Here, too, the throw arm 20 swings through an arc while the axis of the detent spring 88 remains fixed and the considerations with respect to the determination of the inclination for the springs 78 and 79 in detent means 75 can be applied equally to determine the inclination of spring 88. As such, with the throw arm 20 being swung through approximately 18° while engaging spring 88, it is preferable that the axis 90 of spring 88 lie perpendicular to a reference line 91 displaced at approximately 12° from the neutral position of throw arm 20.

Even though this inclination allows the springs to operate most effectively it has been found that the initial angular engagement of the throw arm 20 with the spring 88 will tend to displace the spring away from the throw arm 20. This undesirable result may be obviated by providing a dimple 92 in the throw arm 20 which engages the last coil 93 in spring 88. In this way the spring will be constrained to move with—rather than along—the throw arm 20 as it swings in a direction that compresses the spring 88.

As will hereinafter become more apparent from the description relating to the operation of a preferred form of the subject control 10, it may be very desirable to provide a retaining means 95 by which the throw arm 20 may be held in at least one of its fully displaced positions. Such a retaining means 95 may comprise a base portion 96 (FIG. 4) secured, as by rivet 97, to a mounting flange 98 that extends outwardly of the bridge 51. The pair of resilient arms 99 and 100 that extend outwardly from the spaced ends of the base portion 96 are corrugated to embrace the throw arm 20 and terminate in fingers 101 and 102 that diverge with respect to each other in order to permit a guided entry of the arm 20 into the retaining means 95. The resilient arms 99 and 100 should be of sufficient strength to retain the throw arm and yet permit it to be engaged upon the application of a modest force to the control lever 16.

The wire 104 of an insulated electrical 105 is secured, as by a soldered joint 106, to a spiderlike switching means 108 having three, resilient, conductive blades 109, 110 and 111. The conduit 105 may enter through a passageway 112 between the halves 12A and 12B of the housing assembly 12 and be locked in position by the interengagement of the annular ribs 113 along the interior of the passageway with the outer cover, or insulation, 114 on the wire 104 when the two halves 12A and 12B of the housing assembly are secured together.

Blades 109 and 110 extend outwardly in opposite directions and presents contacts 115 and 116 that lie within the plane through which the throw arm 21 and the centering arm 28, respectively, swing as a result of rotating the control lever 16 about its own axis 22.

Blade 111 extends generally perpendicularly with respect to blades 109 and 110 and presents a contact 118 that lies within the plane through which the throw arm 20 swings as a result of rotating the control lever 16 about axis 23.

When the throw arms 20 and 21 and the centering arm 28 are cylindrical, as depicted, a contact button 119 should be secured on each to assure completion of the circuit required between the switch means 108 and the arms 20, 21, or 28.

The operation of the subject control 10 is probably best understood in the environment of a snowplow, and particularly one in which both lift and turn control are provided.

Referring to FIGS. 8 and 9, a utility device 125 is provided with a blade 126. A typical mount attaches the blade to the vehicle through a compound frame 128. A first frame member 129 is generally triangular with a pair of laterally spaced,

pivotal connections 130 and 131 securing the base thereof to the vehicle 125 for vertically swinging movement. A second frame member 132 is pivotally mounted to the apex of the first frame member 129, as at 133, for horizontal swinging movement. Blade 126 is carried directly on the second frame member 132.

A first cylinder 134 is secured between the vehicle 125 and the first frame member 129 to raise and lower the compound frame 128, and blade 126, about the pivotal connections 130 and 131. The second and third cylinders 135 and 136 are attached between opposite sides of the first frame member 129 and the second frame member 132 to swing the second frame member 132, and blade 126, horizontally about the pivot 133.

A pump and valve unit 138 contains a fluid reservoir, a fluid pump and a valving arrangement whereby fluid may be selectively pumped, under pressure, to the three cylinders 134, 135 and 136 through conduits 139, 140 and 141, respectively.

With the handle 30 oriented in the neutral position, as shown in FIGS. 1 and 2, the cores 36 and 61 are retained in their neutral position and the position of the blade 126 remains fixed. Movement of the control lever 16 along an arc through the plane including guide slots 24 and 25 to the chain line position 16a causes the throw arm 20 to move in an opposite direction to the chain line position 20a (FIG. 2). This movement translates the core 36 of the push-pull cable 35 axially inwardly with respect to the casing 38 and at the same time brings the button contact 119 on throw arm 20 into full engagement with the contact 118 on blade 111 of switch means 108. This engagement completes a circuit from the pump and valve unit 138, via wire 104, through the control unit 10 to ground that activates the pump in unit 138. The aforescribed axial movement of the core 36 positions a valve, not shown, within unit 138 and at the opposite end of cable 35 so that fluid is pumped through conduit 139 to cylinder 134. The admission of pressurized fluid into cylinder 134 raises the frame 128 about the pivotal connections 130 and 131 to raise the blade. The blade 126 is raised to the desired height, and the control lever 16 is permitted to return from the chain line position 16a to the solid line position 16, as under the biasing action of detent 76. This movement retracts the throw arm 20 from the blade 111 to break the circuit from wire 104 to ground and thereby stop the pump in unit 138. The same movement of throw arm 20 also returns the core 36 to the neutral position. In the neutral position the valve in unit 138 causes the pressurized fluid to be retained within cylinder 134, thus maintaining the blade 126 in the elevated position selected.

To lower the blade 126 the control lever 16 is moved from the solid line representation (FIG. 2) to a position depicted by the chain line representation 16b. This movement of control lever 16 to a position opposite position 16a swings the throw arm 20 in a reverse direction along the course defined by the plane including guide slots 24 and 25; that is, away from the switch blade 111 so that the pump in unit 138 remains inoperative. However, this movement of throw arm 20 to the chain line position 20b translates the core 36 axially outwardly of the casing 38, and this motion of core 36 opens the valve, not shown, in unit 138 so that the pressurized fluid in cylinder 134 is relieved. The weight of blade 126 and frame 128 thereby lowers the blade 126 about the pivotal connections 130 and 131. When the blade 126 is lowered to the desired elevation, the control lever is swung from position 16b to position 16. This movement returns the core 36 to its neutral position so that the valve in unit 138 is closed and the vertical position of blade 126 is maintained, as desired.

By employing a detent means 95, when the control lever is moved to position 16b the resilient arms 99 and 100 of the detent means 95 will embrace and retain the throw arm 20 in position 20b until the operator applies a releasing pressure—i.e., a rearwardly directed force against handle 30. When the control 10 is so actuated, only the weight of the blade 126 itself tends to force it downwardly, and it will thus "float" independently of the orientation assumed by the vehicle 125 upon which it is mounted.

Should it be desired to swing the blade 126 to either the right or the left, irrespective of the elevation thereof, this can be accomplished by correspondingly rotating the handle 30 to one direction or the other. For example, should one desire to swing the blade 126 to the right, position 126a depicted in chain line in FIG. 8, he rotates the handle 30—and thus control lever 16—clockwise as depicted in FIG. 1. Clockwise rotation of handle 30 and control lever 16 results in concomitant rotation—or swing—or the throw arm 21 and centering arm 28 about axis 22 to positions 21a and 28a, respectively, depicted in FIG. 3. In order that the arms 21 and 28 may so swing, the axis 22 must be oriented transversely of the plane incorporating guide slots 26 and 29. As such, when the arms 21 and 28 are oriented perpendicularly to the axis 22, as shown in the preferred embodiment, the handle 30 can be rotated only when the throw arm 20 is in its neutral position.

The swinging movement of throw arm 21 to position 21a translates the core 61 of push-pull cable 60 axially outwardly with respect to the casing 62. At the same time, the swinging movement of centering arm 28 to position 28a brings the button contact 119 thereon into full engagement with the contact 116 on blade 110 of switch means 108. This engagement completes a circuit from the pump and valve unit 138, via wire 104, through the control unit 10 to ground that activates the pump in unit 138. This movement of arm 28 also compresses the spring 78 of detent means 75.

The afordescribed axial translation of the core 61 operates a valve (not shown) in unit 138 that opens the conduit 141 to admit pressurized fluid into cylinder 136 and at the same time opens conduit 140 to permit a corresponding amount of fluid to emit from the cylinder 135 so that the blade will swing to the chain line position 126a.

When the blade 126 is in the desired position 126a, the operator need only release handle 30. The spring 78 of detent 75 then acts to return the centering arm 28 and the throw arm 21 from positions 28a and 21a, respectively, to their neutral position. As the centering arm 28 returns to neutral the button contact 119 is retracted from the contact 116 on blade 110 to break the circuit from wire 104 to ground and thereby stop the pump in unit 138. As the throw arm 21 returns to neutral the core 61 is oppositely translated to operate a valve unit 138 that closes both conduits 140 and 141. The blade 126 is thereby maintained in position 126a.

To move the blade 126 in the opposite direction the handle 30, and control lever 16, are rotated in a counterclockwise direction about axis 22. This effects a concomitant counterclockwise rotation of the throw arm 21 and the centering arm 28 about axis 22 to positions 21b and 28b, respectively. Counterclockwise rotation of arm 28 compresses the spring 79 of detent means 75. Counterclockwise rotation of throw arm 21 brings the button contact 119 thereon into full engagement with the contact 115 on blade 109 of switch means 108 to complete the afordescribed circuit that activates the pump in unit 138.

Counterclockwise rotation of throw arm 21 also translates the core 61 of push-pull cable 60 axially inwardly with respect to casing 62. This translation of core 61 operates a valve (not shown) in unit 138 that opens conduit 140 to admit pressurized fluid into cylinder 135 and at the same time opens conduit 141 to permit a corresponding amount of fluid to emit from cylinder 136. In this situation, as well, when the blade 126 has been swung the desired amount, the operator need only release handle 30. The spring 79 of detent 75 then acts to return the centering arm 28 and the throw arm 21 from positions 28b and 21b, respectively, to their neutral position.

It should now be apparent that a single lever control embodying the concept of the present invention is capable of individually regulating at least two motion transmitting means

and an electrical switch means concurrently with selected regulation of the motion transmitting means while otherwise also accomplishing the remaining objects of the invention.

We claim:

1. A single lever control device for selectively actuating a first and second motion transmitting means comprising a housing, first and second throw arms movably mounted within said housing and each said throw arm having an axis and a neutral position, each said throw arm being selectively rotatable through a predetermined range about the axis of the other of said throw arms, the first and second throw arms respectively connected to the first and second motion transmitting means so that rotation of the first throw arm about the axis of said second throw arm actuates the first motion transmitting means and so that rotation of the second throw arm about the axis of said first throw arm actuates the second motion transmitting means, switch means mounted in said housing for actuating a remote electrical device, said switch means being actuated by rotation of said first throw arm in only one direction from neutral and said switch means being actuated by rotation of said second throw arm in either direction from neutral, a centering arm extending oppositely of one said throw arm and rotatable therewith, a control lever extending oppositely of the other said throw arm and rotatable therewith said switch means having three blades, each said blade having a contact portion, said contact portions being selectively located, one in the range of rotational movement of each of said throw arms and said centering arm.

2. A single lever control device, as set forth in claim 1, in which each said throw arm has a neutral position and in which detent means are cooperative with at least one of said throw arms to bias said arm to its neutral position.

3. A single lever control device, as set forth in claim 1, in which the throw arms are each swingingly movable from a neutral position through a range on either side of the neutral position, said ranges each defined by an actuate angle, detent means in the form of springs cooperative with each said throw arm, said throw arms contacting their respective springs through substantially their full range of movement on at least one side of the neutral position, each spring having an axis, the axis of each said spring oriented perpendicularly with respect to the throw arm that comes in contact therewith at one location along the range thereof.

4. A single lever control device, as set forth in claim 3, in which the throw arm is perpendicular to the axis of the spring contacted thereby only when the throw arms has moved through approximately two-thirds of its range from neutral.

5. A single lever control device, as set forth in claim 1, in which at least one of said throw arms has a neutral position and is rotatable through a range defined by an acute angle, a detent means releasably retaining said throw arm at a preselected position within its range, said preselected position being remote from neutral.

6. A single lever control device, as set forth in claim 1, in which both said throw arms have a neutral position, first and second guide means, said first guide means permitting rotation of said first throw arm only when said second throw arm is in its neutral position, and said second guide means permitting rotation of said second throw arm only when said first throw arm is in its neutral position.

7. A single lever control device, as set forth in claim 1, in which at least one of said motion transmitting means comprises a core slidably received within a casing, and in which the connection between the said core and its respective throw arm comprises, a ball secured to said core, a cavity in said throw arm, said ball pivotally received in said cavity, and clip means to retain said ball in said cavity.

UNITED STATES PATENT OFFICE
CERTIFICATE OF CORRECTION

Patent No. 3,585,319 Dated June 15, 1971

Inventor(s) FRANK S. PAYERLE and RICHARD M MOSER

It is certified that error appears in the above-identified patent and that said Letters Patent are hereby corrected as shown below:

Column 3, line 5, change "position" to read "opposition".

Column 4, line 25, change "nd" to read "and".

Column 5, line 43, after "engaged" insert
---or disengaged---

Column 5, line 72, change "device" to read "vehicle".

Column 7, line 9, change "or" (second occurrence) to read
"of".

Column 8, line 2, change "mans" to read "means".

Signed and sealed this 18th day of January 1972.

(SEAL)

Attest:

EDWARD M. FLETCHER, JR.
Attesting Officer

ROBERT GOTTSCHALK
Acting Commissioner of Patents