

March 4, 1924.

1,485,786

J. G. KRAFT

DISPLAY SHELF FOR MERCHANDISE

Filed Oct. 16, 1923

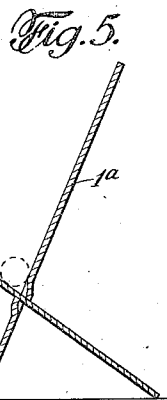
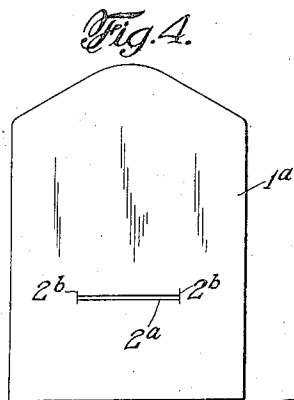
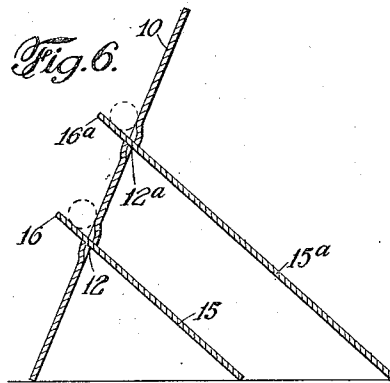
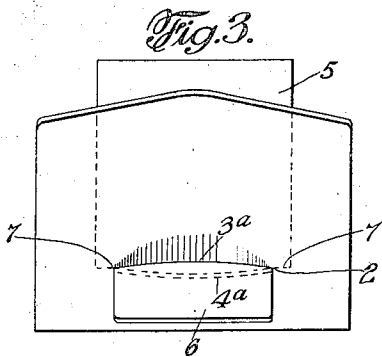
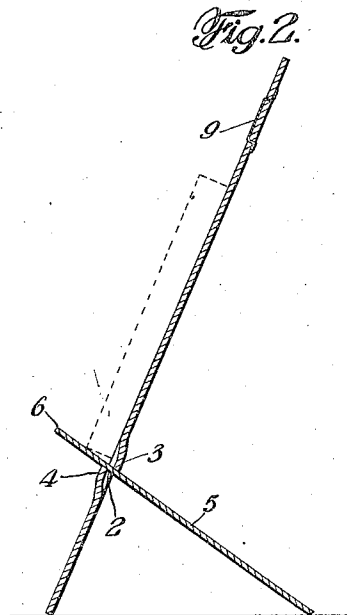
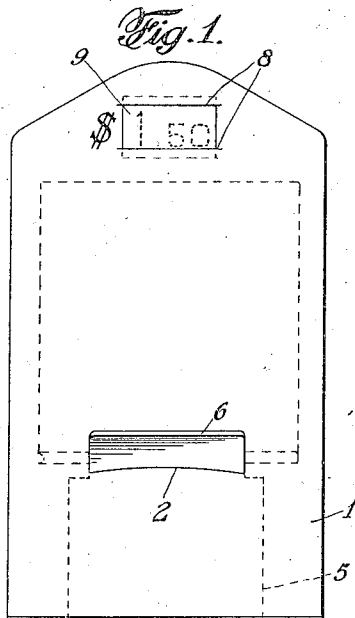

Joseph S. Kraft INVENTOR
BY
Dono P. West Whitaker ATTORNEY.

UNITED STATES PATENT OFFICE.

JOSEPH G. KRAFT, OF ORANGE, NEW JERSEY, ASSIGNOR TO T. V. KRAFT & CO. (CONSISTING OF WILLIAM HUSSENNETTER AND JOSEPH G. KRAFT, COPARTNERS), OF NEW YORK, N. Y.

DISPLAY SHELF FOR MERCHANDISE.

Application filed October 16, 1923. Serial No. 668,815.

To all whom it may concern:

Be it known that I, JOSEPH G. KRAFT, a citizen of the United States, residing at Orange, in the county of Essex and State of New Jersey, have invented certain new and useful Improvements in Display Shelves for Merchandise; and I do hereby declare the following to be a full, clear, and exact description of the invention, such as will enable others skilled in the art to which it appertains to make and use the same.

My invention consists in the novel features hereinafter described, reference being had to the accompanying drawing, which illustrates several forms in which I have contemplated embodying the same, selected by me for purposes of illustration, and the said invention is fully disclosed in the following description and claims.

The object of my invention is to provide a shelf for displaying and supporting articles of merchandise, especially in show windows, counters, cases and cabinets used in stores for the display and sale of merchandise, by means of which various articles of merchandise can be supported in such position as to be readily seen, the supporting shelf being preferably provided with a portion on which the price of the article can be displayed, together with advertising matter, if desired, and the whole device being capable of being constructed very cheaply, while at the same time being sufficiently strong and rigid to support the article or articles placed thereon without danger of being accidentally overturned or otherwise disturbed. My improvement consists preferably of two members composed usually and preferably of comparatively thin card board or other thin and inexpensive sheet material, although obviously they could be formed of sheet metal, celluloid, wood veneer, and any other sheet material which may be found to be suitable. The device comprises a front plate, provided, usually below its vertical center, with a horizontally disposed slot, the edges of the slot being deflected out of alignment with each other, the upper edge extending to the rear of the lower edge, and one or both of said edges being deflected out of the plane of the front plate member, and a supporting plate member provided with portions of greater width than the length of

the slot in the front plate, and with a projecting shelf portion adapted to extend through the slot and project from the front face of the plate member, so as to form a supporting shelf for the article of merchandise to be carried thereon, and said members being held substantially perpendicularly to each other. I have discovered as the result of actual experiment that by constructing this device in the manner described and forming the edges of the slot out of alignment with each other so that the upper edge of the slot will have portions in rear of portions of the front edge of the slot, the edges of the slot will contact with the supporting member so as to lock the two parts of the device together and prevent the rearward or downward movement of the plate member, when the device is placed upon a supporting surface, thus holding the parts very firmly in position and enabling a considerable weight to be supported on the forwardly projecting shelf member. In fact it is found that the effect of placing the weight on the shelf member greatly stiffens the structure and assists in preventing the accidental collapse or displacement of the device.

Referring to the accompanying drawings,

Fig. 1 represents a front view of my improved device in a form convenient for the display of a book, package of merchandise, or other similar article, a book being indicated in dotted lines in supported position.

Fig. 2 is a vertical central sectional view on the line 2—2 of Fig. 1.

Fig. 3 is a top plan view of the device.

Fig. 4 is a front elevation of the plate member showing a slight modification of the device.

Fig. 5 is a central sectional view of the complete device, showing a slight modification of the same, indicated in Fig. 4.

Fig. 6 represents a sectional view of a further modification in which a plurality of supporting shelves are provided in connection with the front plate.

1 represents the front plate member of the device formed preferably of card-board, and provided below its center with a horizontally extending slot, 2, the edges of which are bent or deflected out of alignment with each other so that the upper edge of the slot extends to the rear of the lower edge. This

can be very conveniently done at the time the slot is formed, by means of suitable pressure devices acting in conjunction with the knife or cutter which forms the slot. In some instances the desired result can be accomplished by simply pressing the material at the upper edge of the slot rearwardly out of the plane of the plate member, 1, as indicated at 3, in Fig. 2. The lower edge of the slot may be in the same plane as the rest of the plate member, or it may be bent or pressed forwardly out of the plane of the plate member, 1, as indicated at 4, in Fig. 2. In other words it is essential that the edges of the slot have portions out of alignment with each other, the upper edge of the slot extending to the rear of the lower edge, and this may be accomplished by forcing portions of one or both edges out of alignment with the plate member, as may be preferred. 5 represents the supporting member, the main body portion of which is wider than the slot, 2, as indicated in Fig. 3, and is provided at its upper end with a shelf portion, 6, of a width substantially equal to the length of the slot, 2, forming angular shoulders, 7, where the shelf portion, 6, joins the main body of the support, 5. It will be seen that the shelf, 6, can be readily inserted in the slot, 2, and forced upwardly therein, until the shoulders, 7—7, engage the plate member, and the support, 5, is of such length as to support the plate member in a nearly vertical line, as indicated in Fig. 2, when the device is placed upon a horizontal supporting surface, said members being held substantially perpendicularly to each other. It will be seen that the leverage afforded the support, 5, between the portions, 3 and 4 of the plate member, above and below the slot, 2, enables the support, 5, to not only hold the plate member, 1, in a substantially vertical position, but also enables the resulting structure to resist a considerable strain and permits the forwardly projecting shelf portion, 6, to support a very considerable weight, notwithstanding the thinness and lightness of the material from which the parts are constructed. It will also be seen, by reference to Fig. 2 that when an article, as for example, a book, a package of merchandise as a package of stationery or other material, or a bottle of perfume, or any other article is placed upon the shelf, 6, the weight of the article itself will be largely supported by the lower portion of the plate member, 1, in a substantially direct line from the lower edge of the slot to the bottom edge of the plate member, 1, and that this weight will, as a matter of fact, assist in locking the supporting member, 5, between the staggered edges, 3, and 4, of the slot, 2, so as to render the structure more rigid than it is without the application of the weight of the article.

I have found, by practical experience, that very satisfactory devices of this kind can be made by simply cutting the horizontal slot, 2, in the plate member, 1, and deflecting one or both of the edges of the slot so that they are out of alignment with each other, the deflection being greatest centrally of the length of the slot, as indicated by the curved lines, 3^a, 4^a, in Fig. 3. If it is desired to deflect the edges of the slot throughout the length, this can be readily accomplished, as indicated in Fig. 4, in which 1^a represents the plate member, by forming the slot, 2^a, and providing a transverse slit 2^b, extending vertically at each end of the slot above the same or below the same, or extending both above and below, as indicated in Fig. 4. The formation of these vertical slits, 2^b, makes it possible to deflect either or both the edges of the slot, 2^a, throughout the entire length of the slot, as shown in Fig. 5, and in some instances this construction may be desirable. It is within the scope of my invention, although I prefer to form the slot 2, in the manner indicated in Figs. 1, 2 and 3. It is also within the scope of my invention to provide the plate member with a plurality of supporting members and forwardly projecting shelves, so that the device will support a plurality of articles at the same time. I have illustrated such a construction in Fig. 6, in which 10 represents the plate member, provided with two transverse slots 12 and 12^a, located one above the other, each of which is engaged by a supporting member, indicated at 15, 15^a, having forwardly projecting shelves 16 and 16^a, projecting through and on the forward side of the plate member, 10, so as to support a plurality of articles one above the other. The edges of the slots, 12—12^a, are deflected out of alignment with each other in the manner heretofore described, so that the structure will be braced in the manner heretofore set forth and supported by both the supporting members, 15—15^a, these two members being formed of different lengths, so as to maintain the plate member, 10 in the desired substantially vertical position.

These devices can be made of any desired size, depending upon the character of the article or articles of merchandise intended to be supported on the shelf. For example, a very simple form of the device but a few inches in height and formed of light cardboard, can be conveniently used for the display of knives and other articles of cutlery, lead pencils, fountain pens, cigars and many other forms of merchandise which can be conveniently supported on the forwardly projecting shelf portion. By making the device of slightly heavier cardboard or other suitable material, much larger and heavier objects can be supported and displayed on the projecting shelf portions, and

there is practically no limit to the size and proportions in which the devices may be made, providing the sheet material is of sufficient strength. In making these devices 5 it is preferred that the plate member should extend above the article supported on the projecting shelf a sufficient distance to enable the price of the article to be displayed and appropriate advertising may be placed 10 upon the upper portion of the plate member or upon the lower portion thereof, or both, as desired. In many cases these devices may naturally be printed expressly for the particular articles to be displayed 15 thereon, with appropriate advertising, and the price at which they are offered for sale or the devices may be made blank and the prices as well as the advertising or descriptive matter may be applied by hand.

20 Any suitable means may be employed if desired for detachably affixing the price indications so that these may be changed from time to time in order to permit the device to be used with different articles of 25 merchandise, or articles of merchandise of different prices or to accommodate variations in the price of the articles. In Fig. 1 I have shown a simple arrangement whereby this may be conveniently accomplished 30 in which the plate member, 1, is provided with parallel horizontal slits, indicated at 8—8, to receive a card or plate, 9, which is inserted in these slits and held detachably therein, the figures expressing the price 35 being placed on this removable card, 9.

What I claim and desire to secure by Letters Patent is:—

1. A portable display shelf for merchandise comprising a front plate member provided with a horizontal closed slot located 40 substantially centrally of its width, a separately formed supporting plate member arranged to extend through said slot to form a shelf portion in front of the front plate 45 member and a brace member at the rear of the same, said members being in substantially perpendicular relation to each other when in set position, and means predeter-

mining the extent which said shelf portion projects from the front of said front plate 50 member.

2. A portable display shelf for merchandise comprising a front plate member provided with a horizontal slot located substantially centrally of its width, a separately formed supporting plate member arranged to extend through said slot to form a shelf portion in front of the front plate member and a brace member at the rear of the same, the upper edge of said slot engaging the supporting plate member in rear of the engagement of the lower edge of the slot therewith, said members being in substantially perpendicular relation to each other when in set position, and means predetermining the extent which said shelf portion projects from the front face of said front plate member.

3. A portable display shelf for merchandise comprising a front plate member provided with a horizontal closed slot located substantially centrally of its width, a separately formed supporting plate member arranged to extend through said slot to form a shelf portion in front of the front 75 plate member and a brace member at the rear of the same, and shoulders extending laterally of the shelf portion and arranged to engage the rear face of said front plate member to predetermine the extent which 80 said shelf portion projects from the front of said front plate member.

4. A portable display shelf for merchandise comprising a front plate member provided with a horizontal closed slot located 85 substantially centrally of its width, a separately formed supporting plate member arranged to extend through said slot to form a shelf portion in front of the front plate member and a brace member at the rear 90 of the same, and means predetermining the extent which said shelf portion projects from the front of said front plate member.

In testimony whereof I affix my signature.

JOSEPH G. KRAFT.