

Feb. 7, 1933.

L. S. MADDEN

1,896,965

PORTABLE DESK TOP

Filed May 13, 1932

2 Sheets-Sheet 1

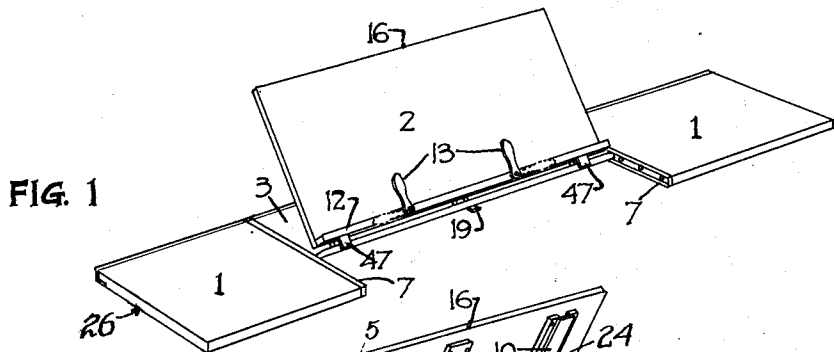

FIG. 1

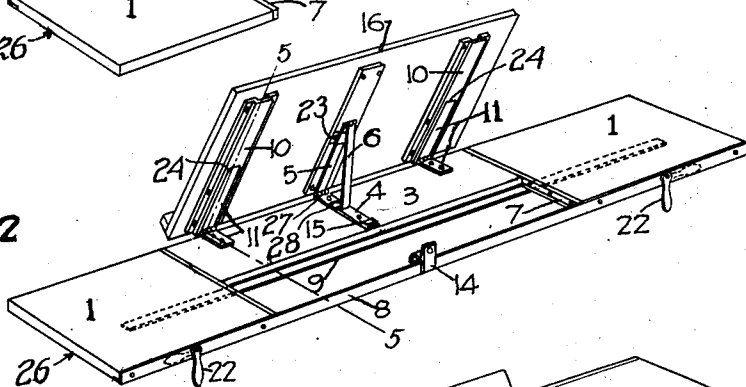

FIG. 2

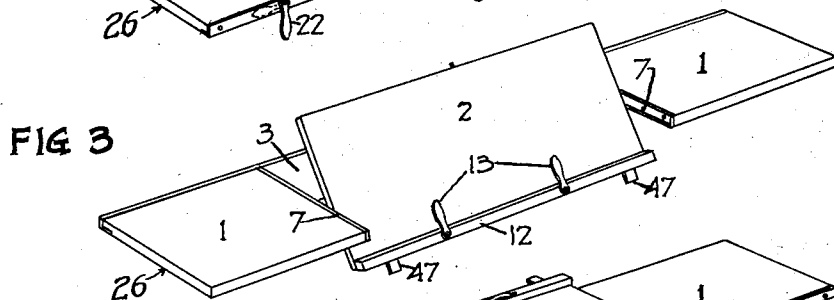

FIG. 3

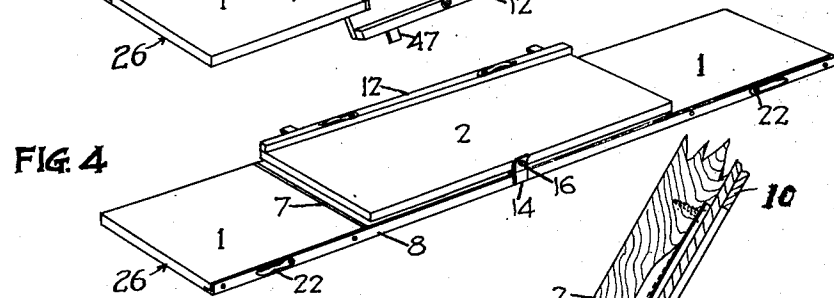

FIG. 4

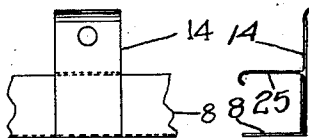

FIG. 6

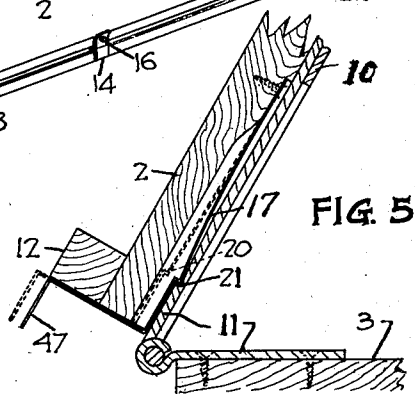

FIG. 7

Leland S. Madden Inventor

By *E. S. Ford* Attorney

UNITED STATES PATENT OFFICE

LELAND S. MADDEN, OF PLEASANTVILLE, NEW JERSEY

PORTABLE DESK TOP

Application filed May 13, 1932. Serial No. 611,210.

This invention relates to reading or work tables for arm-chairs particularly of the type adapted to be positioned to rest upon the arms of the chair, but also suitable for use on any other appropriate support.

The object of the invention is primarily to give ease and comfort in reading by relieving the user of the necessity of holding the article or book being read and afford the advantage of allowing at the same time the use of the hands for other purposes such as writing, etc.; also securing the very important advantage of proper range of vision both horizontally and vertically, all of which will hereinafter be more fully described and claimed.

Referring to the accompanying drawings, which are made a part hereof and on which similar reference characters indicate similar parts.

Figure 1 is a perspective view of the front of the device with the center section positioned at the rear,

Figure 2, a perspective rear view with the center section in a forward position,

Figure 3, a perspective front view with the center section in a rearward position showing the vertical range of the rack,

Figure 4, a perspective view of the device in folded position,

Figure 5, a section on line 5—5 of Figure 2 showing the sliding arrangement of the rack on the upper leaf of the hinge,

Figures 6 and 7 are detail views of the spring used for holding the device closed when folded and for retaining the sliding section in a rearward position,

Figure 8, a rear view in elevation of the device in open position, and

Figure 9, an enlarged section on line 9—9 of Figure 8.

In the drawings reference character 1 indicates sections of the base 26 of the device connected by means of the braces 8 and 9 and of a sufficient length to bridge the arms of a chair. The inner edges of the sections of the base 26 are provided with channels or grooves 7 in which the center section 3 is slidably mounted, the section 3 being of a width somewhat less than the width of the sections 1.

Securely fastened to one edge of the sliding

section 3 are two side hinges 11 and a center hinge 27 formed of the portions 4, 5, and 6. The other ends of the side hinge 11 and the middle portion 5 of the center hinge 27 are loosely positioned and held by the covered channel members 10 provided with the cut-out portion 24 and the cleat 23 respectively to the rack 2. The third portion 6 of the center hinge 27 is allowed to swing freely and serves to support the rack 2 at the angle of elevation with respect to the base 26 that may be desired. The portion 4 of center hinge 27 is provided in its top surface with transverse notches or ribs 28 spaced to engage the free end of the portion 6 and hold the rack 2 at the elevation desired. Rack 2 is held at its most elevated position as regards its horizontal axis as shown in Figure 5 by the sharp flange 20 of the embedded spring 17 which engages the notch 21 on the hinge 11. By releasing the spring 17 from the notch 21 the rack 2 is allowed to slide down and its total descent is governed by the distance from the lower end of the channel members 10 to the top edge of the cut-out portion 24 of the channel member 10 and the bottom of the cleat 23 which engage the joints of the hinges. From its lowest horizontal axis the rack 2 is changed to its highest horizontal axis simply by pushing upward on the rack until the flange 20 of the spring 17 automatically engages the notch 21. In this manner the horizontal axis of the rack and the vertical range of vision are easily changed. Referring to the drawings it is evident that the varying of the angle of the rack with respect to the base is not affected by the changing of the horizontal axis and numerous ranges and angles of vision adjustments can be made.

Numeral 12 of Fig. 1 shows a projecting ledge for keeping a book on the rack and 13 indicates the spring clips positioned on the ledge for holding the book open. The clips may be rotated to a position parallel with the ledge when not in use. A spring clip 14 is secured to the center of the brace 8 for engaging a pin 16 on the edge of the rack 2 when in closed position and the horizontal hooked portion 25 of the spring clip 14 as shown in Fig. 7 engages in the notch 15 of the portion

4 of the center hinge to hold the sliding section 3 rearwardly when the device is used on backward slanting chair arms. A stop 19 is positioned on the under surface of the sliding section 3 to prevent the rack 2 rotating too far forward when its horizontal axis is close to the center of the rack. The springs 17 are provided with the extensions 47 on the front ends for use of the fingers in releasing the flanges 20 of the springs 17 from the notches 21 as clearly shown in Fig. 5. The clips 22 are provided for engaging the ends of chair arms to prevent the base 26 from sliding when used on steep slanting arms. The clips 22 may be rotated to a position parallel to the base when not in use.

The uses and advantages of the device are apparently obvious from the above description. The center section with the rack may be moved forward and backward horizontally in the grooves. The angle at which the rack is held with respect to the base is easily adjusted by inserting the free end of the portion 6 in the notches 28. The hinges being loosely mounted in the rack allow the rack to be raised or lowered vertically thereby shifting the horizontal axis of the rack. All adjustments can be made independent of the other to suit the particular conditions and range of vision at which the device is to be used. It also has the convenience of being easily folded and placed out of the way when not in use. While I have designed this device particularly for use as a reading table or desk for use on the arms of an ordinary arm-chair it will be seen that it may be found adapted for use for many purposes and may be mounted for use on any appropriate support as well as on the arms of a chair.

It will be obvious to those skilled in the art that variations may be made in details of arrangement, material, size, proportion and other minor details that do not alter the principle of the invention, and therefore I do not limit myself to what is shown in the drawings and described in the specification, but only as indicated by the appended claims.

Having thus fully described my said invention, what I claim as new and desire to secure by Letters Patent, is:

1. A device of the kind described comprising a base having a center section slidably mounted therein, a rack pivotally and slidably mounted on said section, and means for adjustably positioning said rack with respect to said base, substantially as set forth.

2. A device of the kind described comprising a base having two end sections, braces connecting said end sections, an intermediate section slidably mounted between said end sections, a rack, hinges fixed at one side to said intermediate section and slidably secured at the other side to and for pivotally mounting said rack, and means on said rack engageable with said hinges for holding said

rack in an elevated position above said base, substantially as set forth.

3. A device of the kind described comprising a base having a center section slidably transversely therein, a rack pivotally mounted on said section, said rack being provided with slotted channels on the back thereof, hinges secured at one end to said center section and slidably secured at the other end in said slotted channels, resilient means engageable with said hinges for holding said rack above the surface of said base, substantially as set forth.

4. A device of the kind described comprising a base having a center section slidably transversely therein, a rack pivotally mounted on said section, said rack being provided with slotted channels on the back thereof, hinges secured at one end to said center section and slidably secured at the other end in said slotted channels, resilient means engageable with said hinges for holding said rack above the surface of said base, and an arm on one of said hinges engageable with said center section for varying the angle of elevation of said rack with respect to said base, substantially as set forth.

5. A device of the kind described comprising a base having a center section slidably mounted therein, a rack having channel members fixed to the back thereof, hinges slidably positioned in said channel members and fixed to said center section for pivotally mounting said rack, said rack being provided with releasable resilient means for engaging said hinges for holding said rack in an elevated position above said base, substantially as set forth.

6. A device of the kind described comprising a base having a center section slidably mounted therein, a rack having channel members fixed to the back thereof, hinges slidably positioned in said channel members and fixed to said center section for pivotally mounting said rack, said rack being provided with releasable resilient means for engaging said hinges for holding said rack in an elevated position above said base, and means secured to the rear edge of said base adapted to engage and hold said rack in a collapsed and rearward position, substantially as set forth.

7. A device of the kind described comprising a base having end sections, a center section slidably mounted between said end sections, a rack adapted to support a book provided with channel members on the back thereof, hinges slidably mounted in said channel members and secured to said center section for pivotally mounting said rack on said section, one of said hinges being provided with a depending arm for engaging said center section for varying the angle of elevation of said rack, the other of said hinges being provided with means associated with resilient means on said rack for shifting the

1,896,965

3

horizontal axis of said rack, substantially as set forth.

In witness whereof, I have hereunto set my hand at Washington, District of Columbia, this 4th day of May, A. D. nineteen hundred and thirty-two.

LELAND S. MADDEN.

10
15
20
25
30
35
40
45
50
55