



- (51) International Patent Classification:
A61F 13/15 (2006.01) *D04H 1/485* (2012.01)
- (21) International Application Number:
PCT/US2012/030266
- (22) International Filing Date:
23 March 2012 (23.03.2012)
- (25) Filing Language: English
- (26) Publication Language: English
- (30) Priority Data:
61/467,513 25 March 2011 (25.03.2011) US
- (71) Applicant (for all designated States except US): **THE PROCTER & GAMBLE COMPANY** [US/US]; One Procter & Gamble Plaza, Cincinnati, Ohio 45202 (US).
- (72) Inventors; and
- (75) Inventors/Applicants (for US only): **XU, Han** [CN/US]; 5780 Kugler Mill Road, Cincinnati, Ohio 45236 (US). **DE BEER, Antonius, Lambertus** [US/US]; 10131 Fox Chase Drive, Loveland, Ohio 45140 (US). **ISELE, Olaf, Erik Alexander** [DE/US]; 8772 Rupp Farm Drive, West Chester, Ohio 45069 (US). **KLÁŠKA, František** [CZ/CZ]; Zámecká 1405, 684 01 Slavkov U Brna (CZ). **KUMMER, Jirí** [CZ/CZ]; Drnovice 636, 683 04 Drnovice (CZ). **MECL, Zdenek** [CZ/CZ]; Nový Šaldorf 192, 671 81 Nový

Šaldorf-Sedlešovice (CZ). **KAŠPÁRKOVÁ, Pavlína** [CZ/CZ]; Gránická 1586/18, 669 02 Znojmo (CZ).

- (74) Common Representative: **THE PROCTER & GAMBLE COMPANY**; c/o Eileen L. Hughett, Global Patent Services, 299 East Sixth Street, Sycamore Building, 4th Floor, Cincinnati, Ohio 45202 (US).
- (81) Designated States (unless otherwise indicated, for every kind of national protection available): AE, AG, AL, AM, AO, AT, AU, AZ, BA, BB, BG, BH, BR, BW, BY, BZ, CA, CH, CL, CN, CO, CR, CU, CZ, DE, DK, DM, DO, DZ, EC, EE, EG, ES, FI, GB, GD, GE, GH, GM, GT, HN, HR, HU, ID, IL, IN, IS, JP, KE, KG, KM, KN, KP, KR, KZ, LA, LC, LK, LR, LS, LT, LU, LY, MA, MD, ME, MG, MK, MN, MW, MX, MY, MZ, NA, NG, NI, NO, NZ, OM, PE, PG, PH, PL, PT, QA, RO, RS, RU, RW, SC, SD, SE, SG, SK, SL, SM, ST, SV, SY, TH, TJ, TM, TN, TR, TT, TZ, UA, UG, US, UZ, VC, VN, ZA, ZM, ZW.
- (84) Designated States (unless otherwise indicated, for every kind of regional protection available): ARIPO (BW, GH, GM, KE, LR, LS, MW, MZ, NA, RW, SD, SL, SZ, TZ, UG, ZM, ZW), Eurasian (AM, AZ, BY, KG, KZ, MD, RU, TJ, TM), European (AL, AT, BE, BG, CH, CY, CZ, DE, DK, EE, ES, FI, FR, GB, GR, HR, HU, IE, IS, IT, LT, LU, LV, MC, MK, MT, NL, NO, PL, PT, RO, RS, SE, SI, SK, SM, TR), OAPI (BF, BJ, CF, CG, CI, CM, GA, GN, GQ, GW, ML, MR, NE, SN, TD, TG).

[Continued on next page]

- (54) Title: ARTICLE WITH NONWOVEN WEB COMPONENT FORMED WITH LOFT-ENHANCING CALENDER BOND SHAPES AND PATTERNS

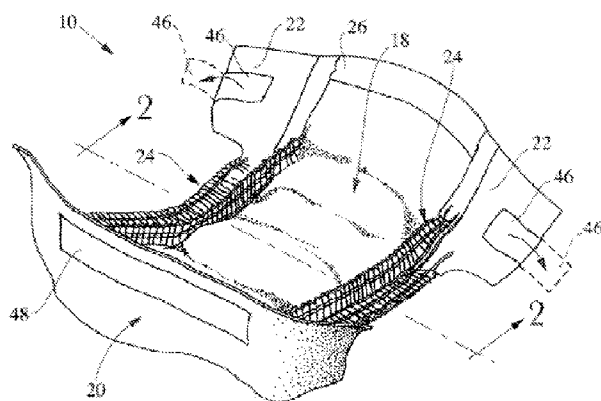

Fig. 1A

(57) Abstract: An article having as a component a section of nonwoven web formed predominately of polymeric fibers is disclosed. The section of nonwoven web may have a pattern of consolidating bonds impressed on the surface. The bonds may have at least one bond shape; and the bond shape may have a perimeter with a greatest measurable length and greatest measurable width. The perimeter may have a convex portion and an aspect ratio of length/width of at least 2.5. Other features may be imparted relating to the density and orientations of the bonds relative machine and cross directions of the web. The bond shape reflects the shape of a corresponding bonding protrusion on a bonding roller. It is believed that the shape, density and/or orientation of the bonding protrusions affect air flow through the bonding nip in a way that may be utilized to enhance loft of the resulting bonded nonwoven web.



Published:

— *with international search report (Art. 21(3))*

ARTICLE WITH NONWOVEN WEB COMPONENT FORMED WITH LOFT-ENHANCING CALENDER BOND SHAPES AND PATTERNS

BACKGROUND OF THE INVENTION

The business of manufacturing and marketing disposable absorbent articles for personal care or hygiene (such as disposable diapers, training pants, adult incontinence undergarments, feminine hygiene products, breast pads, care mats, bibs, wound dressing products, and the like) is relatively capital intensive and highly competitive. To maintain or grow their market share and thereby maintain a successful business, manufacturers of such articles must continually strive to enhance their products in ways that serve to differentiate them from those of their competitors, while at the same time controlling costs so as to enable competitive pricing and the offering to the market of an attractive value-to-price proposition.

One way in which some manufacturers may seek to enhance such products is through enhancements to softness. Parents and caregivers naturally seek to provide as much comfort as they can for their babies, and utilizing products such as disposable diapers that they perceive as relatively soft provides reassurance that they are doing what they can to provide comfort in that context. With respect to other types of disposable absorbent articles that are designed to be applied and/or worn close to the skin, an appearance of softness can reassure the wearer or caregiver that the article will be comfortable.

Thus, manufacturers may devote efforts toward enhancing the softness of the various materials used to make such products, such as various web materials, including nonwoven web materials formed from polymer fibers, and laminates thereof, forming the products. Such laminates may include, for example, laminates of polymer films and nonwoven web materials forming the backsheet components of the products.

It is believed that humans' perceptions of softness of a nonwoven web material can be affected by tactile signals, auditory signals and visual signals.

Tactile softness signals may be affected by a variety of the material's features and properties that have effect on its tactile feel, including but not limited to loft, fiber shape, thickness and density, basis weight, microscopic pliability and flexibility of individual fibers, macroscopic pliability and flexibility of the nonwoven web as formed by the fibers, surface friction characteristics, number of loose fibers or free fiber ends, and other features.

Perceptions of softness also may be affected by auditory signals, *e.g.*, whether and to what extent the material makes audible rustling, crinkling or other noises when touched or manipulated.

It is believed that perceptions of softness of a material also may be affected by visual signals, *i.e.*, its visual appearance. It is believed that, if a nonwoven material *looks* relatively soft to a person, it is much more likely that the person will perceive it as having relative tactile softness as well. Visual impressions of softness may be affected by a variety of features and properties, including but not limited to color, opacity, light reflectivity, refractivity or absorption, apparent thickness/caliper, fiber size and density, and macroscopic physical surface features.

As a result of the complexity of the mix of the above-described characteristics, to the extent softness is considered an attribute of a nonwoven web material, it may elude precise measurement or quantification. Although several methods for measuring and evaluating material features that are believed to affect softness signals have been developed, there are no standard, universally accepted units or methods of measurement for softness. It is a subjective, relative concept, difficult to characterize in an objective way. Because softness is difficult to characterize, it can also be difficult to affect in a predictable way, through changes or adjustments to specifications in materials or manufacturing processes.

Complicating efforts to define and enhance softness is the fact that differing individuals will have differing individual physiological and experiential frames of reference and perceptions concerning what material features and properties will cause them to perceive softness to a lesser or greater extent in a material, and relative other materials.

Loft in nonwovens may have importance for reasons in addition to or other than creating an impression of softness. In some applications, nonwovens may be used as components of cleaning articles, such as wipes or dusters. Improving loft of such a nonwoven can also improve its efficacy as a cleaning element. In another particular application, a nonwoven may be used to form the loops component of a hook-and-loop fastening system. Improving loft of such a nonwoven can improve its suitability for this purpose.

Various efforts have been made to provide or alter features of nonwoven web materials with the objective of enhancing loft and/or consumer perceptions of softness. These efforts have included selection and/or manipulation of fiber chemistry, basis weight, loft, fiber density, configuration and size, tinting and/or opacifying, embossing or bonding in various patterns, etc.

For example, one approach to enhancing perceived softness of a nonwoven web has involved simply increasing the basis weight of the web, otherwise manufactured through a

spunlaid/spunbond process that includes formation of a batt of loose spun fibers and then consolidating by calender-bonding in a pattern. All other variables remaining constant, increasing the basis weight of such a web will have the effect of increasing the number of fibers per unit surface area, and correspondingly, increasing apparent thickness, fiber density and/or loft. This approach might be deemed effective if the only objective is increasing depth and/or loft signals affecting perceptions of softness, *i.e.*, simply increasing the basis weight of a spunbond nonwoven is one way to increase its depth or loft. However, among the costs involved in producing nonwoven web material formed of polymer fibers is the cost of the polymer resin(s) from which the fibers are spun. Higher basis weight nonwovens require more resin to produce, and therefore, cost more per unit. Thus, attempting to enhance loft and/or perceived softness by increasing nonwoven basis weight is incompatible with the ever-present objective of controlling or reducing costs.

Another approach has involved forming a nonwoven web of "bicomponent" polymer fibers, by spinning such fibers, laying them to form a batt and then consolidating them by calender-bonding with a pattern, selected to provide visual effects. Such bicomponent polymer fibers may be formed by spinnerets that have two adjacent sections, that express a first polymer from one and a second polymer from the other, to form a fiber having a cross section of the first polymer in one portion and the second polymer in the other (hence the term "bicomponent"). The respective polymers may be selected so as to have differing melting temperatures and/or expansion-contraction rates. These differing attributes of the two polymers, when combined in a side by side or asymmetric sheath-core geometry, cause the bicomponent fiber products to curl in the spinning process, as they are cooled and drawn from the spinnerets. The resulting curled fibers then may be laid down in a batt and calender-bonded in a pattern. It is thought that the curl in the fibers adds loft and fluff to the web, enhancing visual and tactile softness signals.

In another approach relating to a backsheet laminate of a film and a non-woven web, prior to lamination with a nonwoven web the film is printed with a subtle pattern which, following lamination with the nonwoven web, is visible therethrough and simulates actual shading that would occur on the nonwoven web surface under various lighting conditions, as if it actually bore a pattern of three-dimensional surface features. The desired effect is to enhance visual softness signals.

Still another approach has involved subjecting the web to a hydroenhancing or hydroengorgement process following calender-bonding, to fluff the fibers and increase caliper

and loft. It is believed that the hydroenhancing/hydroengorgement process increases loft and caliper in a manner that enhances visual and tactile softness signals.

The approaches described above and others have had varying degrees of success, but have left room for improvement in enhancing loft and visual and/or tactile softness signals.

Additionally, many current methods for enhancing softness signals in a nonwoven web have the undesirable effect of decreasing desirable mechanical properties such as tensile strength, and may also add cost to the web manufacturing process in the form of additional materials or additional equipment and energy required for processing steps.

The challenge to improve loft and/or softness becomes more difficult as nonwoven web basis weight is reduced, because, as basis weight is reduced, fewer fibers per unit surface area are available to contribute to loft and opacity of the web.

BRIEF DESCRIPTION OF THE DRAWINGS

Fig. 1A is a perspective view of a disposable diaper shown laid out horizontally in a relaxed condition, wearer-facing surfaces up;

Fig. 1B is a plan view of a disposable diaper shown laid out horizontally in a stretched out, flattened state (stretched out against elastic contraction induced by the presence of elastic members), wearer-facing surfaces facing the viewer;

Fig. 2A is a cross section of the diaper depicted in Figs. 1A and 1B, taken through line 2-2 in those figures;

Fig. 2B is a schematic cross section of a portion of a laminate of a polymeric film and a nonwoven web, taken through a pattern of bond impressions in the nonwoven web;

Fig. 3 is a simplified schematic view of a batt moving through the nip between calender rollers to form a calender-bonded nonwoven web;

Fig. 4A is a view of a pattern of bonding surface shapes of bonding protrusions that may be imparted to the surface of a calender roller, to create a corresponding pattern of consolidating bond impressions having bond shapes in a nonwoven web;

Fig. 4B is a view of another pattern of bonding surface shapes of bonding protrusions that may be imparted to the surface of a calender roller, to create another corresponding pattern of consolidating bond impressions having bond shapes in a nonwoven web;

Fig. 4C is a magnified view of the pattern of bonding surface shapes of bonding protrusions or consolidating bond impressions having bond shapes appearing in Fig. 4B;

Fig. 5A is a view of another pattern of bonding surface shapes of bonding protrusions that may be imparted to the surface of a calender roller, to create another corresponding pattern of consolidating bond impressions having bond shapes in a nonwoven web;

Fig. 5B is a magnified view of the pattern of bonding surface shapes of bonding protrusions or consolidating bond impressions having bond shapes appearing in Fig. 5A;

Fig. 5C is a magnified view of the pattern of bonding surface shapes of bonding protrusions or consolidating bond impressions having bonding impressions appearing in Fig. 5A;

Fig. 6A is a view of another pattern of bonding surface shapes of bonding protrusions that may be imparted to the surface of a calender roller, to create another corresponding pattern of consolidating bond impressions having bond shapes in a nonwoven web;

Fig. 6B is a magnified view of the pattern of bonding surface shapes of bonding protrusions or consolidating bond impressions having bond shapes appearing in Fig. 6A; and

Fig. 7 is a view of another pattern of bonding surface shapes of bonding protrusions that may be imparted to the surface of a calender roller, to create another corresponding pattern of consolidating bond impressions having bond shapes in a nonwoven web.

DETAILED DESCRIPTION OF THE INVENTION

Definitions

"Absorbent article" refers to devices that absorb and contain body exudates, and, more specifically, refers to devices that are placed against or in proximity to the body of the wearer to absorb and contain the various exudates discharged from the body. Absorbent articles may include diapers, training pants, adult incontinence undergarments and pads, feminine hygiene pads, breast pads, care mats, bibs, wound dressing products, and the like. As used herein, the term "exudates" includes, but is not limited to, urine, blood, vaginal discharges, breast milk, sweat and fecal matter.

"Absorbent core" means a structure typically disposed between a topsheet and backsheet of an absorbent article for absorbing and containing liquid received by the absorbent article. The absorbent core may also include a cover layer or envelope. The cover layer or envelope may comprise a nonwoven. In some examples, the absorbent core may include one or more substrates, an absorbent polymer material, and a thermoplastic adhesive material/composition adhering and immobilizing the absorbent polymer material to a substrate, and optionally a cover layer or envelope.

"Absorbent polymer material," "absorbent gelling material," "AGM," "superabsorbent," and "superabsorbent material" are used herein interchangeably and refer to cross linked

polymeric materials that can absorb at least 5 times their weight of an aqueous 0.9% saline solution as measured using the Centrifuge Retention Capacity test (Edana 441.2-01).

"Absorbent particulate polymer material" is used herein to refer to an absorbent polymer material which is in particulate form so as to be flowable in the dry state.

"Absorbent particulate polymer material area" as used herein refers to the area of the core wherein the first substrate and second substrate are separated by a multiplicity of superabsorbent particles. There may be some extraneous superabsorbent particles outside of this area between the first substrate 64 and second substrate.

"Airfelt" is used herein to refer to comminuted wood pulp, which is a form of cellulosic fiber.

A "batt" is used herein to refer to fiber materials prior to being consolidated in a final calendering process as described herein. A "batt" comprises individual fibers, which are usually unbonded to each other, although a certain amount of pre-bonding between fibers may be performed and is also included in the meaning, such as may occur during or shortly after the lay-down of fibers in a spunlaying process, or as may be achieved by a pre-calendering. This pre-bonding, however, still permits a substantial number of the fibers to be freely moveable such that they can be repositioned. A "batt" may comprise several strata, such as may result from depositing fibers from several beams in a spunlaying process.

"Bicomponent" refers to fiber having a cross-section comprising two discrete polymer components, two discrete blends of polymer components, or one discrete polymer component and one discrete blend of polymer components. "Bicomponent fiber" is encompassed within the term "multicomponent fiber." A Bicomponent fiber may have an overall cross section divided into two or more subsections of the differing components of any shape or arrangement, including, for example, coaxial subsections, core-and-sheath subsections, side-by-side subsections, radial subsections, etc.

"Bond area percentage" on a nonwoven web is a ratio of area occupied by bond impressions, to the total surface area of the web, expressed as a percentage, and measured according to the Bond Area Percentage Method set forth herein.

"Bonding roller," "calender roller" and "roller" are used interchangeably.

A "bond impression" in a nonwoven web is the surface structure created by the impression of a bonding protrusion on a calender roller into a nonwoven web. A bond impression is a location of deformed, intermeshed or entangled, and melted or thermally fused, materials from fibers superimposed and compressed in a z-direction beneath the bonding

protrusion, which form a bond. The individual bonds may be connected in the nonwoven structure by loose fibres between them. The shape and size of the bond impression approximately corresponds to the shape and size of the bonding surface of a bonding protrusion on the calender roller.

A "column" of bonds on a nonwoven web is a group of nearest neighboring bonds of like shape and rotational orientation that are arranged along the line that extends most predominately in the machine direction.

"Cross direction"(CD) – with respect to the making of a nonwoven web material and the nonwoven web material, refers to the direction along the web material substantially perpendicular to the direction of forward travel of the web material through the manufacturing line in which the web material is manufactured. With respect to a batt moving through the nip of a pair of calender rollers to form a bonded nonwoven web, the cross direction is perpendicular to the direction of movement through the nip, and parallel to the nip.

"Disposable" is used in its ordinary sense to mean an article that is disposed or discarded after a limited number of usage events over varying lengths of time, for example, less than about 20 events, less than about 10 events, less than about 5 events, or less than about 2 events.

"Diaper" refers to an absorbent article generally worn by infants and incontinent persons about the lower torso so as to encircle the waist and legs of the wearer and that is specifically adapted to receive and contain urinary and fecal waste. As used herein, term "diaper" also includes "pant" which is defined below.

"Fiber" and "filament" are used interchangeably.

"Fiber diameter" is expressed in units of μm . The terms "grams of fiber per 9000 m" (denier or den) or "grams of fiber per 10000 m" (dTex) are used to describe the fineness or coarseness of fibers, which are linked to the diameter (when assumed to be circular) by the density of the employed material(s).

"Film" – means a skin-like or membrane-like layer of material formed of one or more polymers, which does not have a form consisting predominately of a web-like structure of consolidated polymer fibers and/or other fibers.

"Length" or a form thereof, with respect to a diaper or training pant, refers to a dimension measured along a direction perpendicular to the waist edges and/or parallel to the longitudinal axis.

"Machine direction" (MD) – with respect to the making of a nonwoven web material and the nonwoven web material, refers to the direction along the web material substantially parallel

to the direction of forward travel of the web material through the manufacturing line in which the web material is manufactured. With respect to a nonwoven batt moving through the nip of a pair of calender rollers to form a bonded nonwoven web, the machine direction is parallel to the direction of movement through the nip, and perpendicular to the nip.

“Monocomponent” refers to fiber formed of a single polymer component or single blend of polymer components, as distinguished from bicomponent or multicomponent fiber.

“Multicomponent” refers to fiber having a cross-section comprising more than one discrete polymer component, more than one discrete blend of polymer components, or at least one discrete polymer component and at least one discrete blend of polymer components.

“Multicomponent fiber” includes, but is not limited to, “bicomponent fiber.” A multicomponent fiber may have an overall cross section divided into subsections of the differing components of any shape or arrangement, including, for example, coaxial subsections, core-and-sheath subsections, side-by-side subsections, radial subsections, islands-in-the-sea, etc.

A "nonwoven" is a manufactured sheet or web of directionally or randomly oriented fibers which are first formed into a batt and then consolidated and bonded together by friction, cohesion, adhesion or one or more patterns of bonds and bond impressions created through localized compression and/or application of pressure, heat, ultrasonic or heating energy, or a combination thereof. The term does not include fabrics which are woven, knitted, or stitch-bonded with yarns or filaments. The fibers may be of natural or man-made origin and may be staple or continuous filaments or be formed in situ. Commercially available fibers have diameters ranging from less than about 0.001 mm to more than about 0.2 mm and they come in several different forms: short fibers (known as staple, or chopped), continuous single fibers (filaments or monofilaments), untwisted bundles of continuous filaments (tow), and twisted bundles of continuous filaments (yarn). Nonwoven fabrics can be formed by many processes including but not limited to meltblowing, spunbonding, spunmelting, solvent spinning, electrospinning, carding, film fibrillation, melt-film fibrillation, airlaying, dry-laying, wetlaying with staple fibers, and combinations of these processes as known in the art. The basis weight of nonwoven fabrics is usually expressed in grams per square meter (gsm).

“Opacity” is a numeric value relating to the ability of a web material to transmit light therethrough, measured according the Opacity Measurement Method set forth herein.

"Pant" or "training pant", as used herein, refer to disposable garments having a waist opening and leg openings designed for infant or adult wearers. A pant may be placed in position on the wearer by inserting the wearer's legs into the leg openings and sliding the pant into

position about a wearer's lower torso. A pant may be preformed by any suitable technique including, but not limited to, joining together portions of the article using refastenable and/or non-refastenable bonds (*e.g.*, seam, weld, adhesive, cohesive bond, fastener, etc.). A pant may be preformed anywhere along the circumference of the article (*e.g.*, side fastened, front waist fastened). While the terms "pant" or "pants" are used herein, pants are also commonly referred to as "closed diapers," "prefastened diapers," "pull-on diapers," "training pants," and "diaper-pants". Suitable pants are disclosed in U.S. Pat. No. 5,246,433, issued to Hasse et al. on September 21, 1993; U.S. Pat. No. 5,569,234, issued to Buell et al. on October 29, 1996; U.S. Pat. No. 6,120,487, issued to Ashton on September 19, 2000; U.S. Pat. No. 6,120,489, issued to Johnson et al. on September 19, 2000; U.S. Pat. No. 4,940,464, issued to Van Gompel et al. on July 10, 1990; U.S. Pat. No. 5,092,861, issued to Nomura et al. on March 3, 1992; U.S. Patent Publication No. 2003/0233082 A1, entitled "Highly Flexible And Low Deformation Fastening Device", filed on June 13, 2002; U.S. Pat. No. 5,897,545, issued to Kline et al. on April 27, 1999; U.S. Pat. No. 5,957,908, issued to Kline et al. on September 28, 1999.

When used as an adjective in connection with a component of a material, the term "predominately" means that the component makes up greater than 50% by weight of the material. When used as an adjective in connection with a directional orientation of a physical feature or geometric attribute thereof, "predominately" means the feature or attribute has a projection onto a line extending along the direction indicated, greater in length than the projection onto a line perpendicular thereto. Within other context, the term "predominantly" refers to a condition which imparts a substantial effect on a property or feature. Thus, when a material comprises "predominantly" a component said to impart a property, this component imparts a property that the material otherwise would not exhibit. For example, if a material comprises "predominantly" heat-fusible fibers, the quantity and components of these fibers must be sufficient to allow heat fusion of the fibers.

A "bonding protrusion" or "protrusion" is a feature of a bonding roller at its radially outermost portion, surrounded by recessed areas. Relative the rotational axis of the bonding roller, a bonding protrusion has a radially outermost bonding surface with a bonding surface shape and a bonding surface shape area, which generally lies along an outer cylindrical surface with a substantially constant radius from the bonding roller rotational axis; however, protrusions having bonding surfaces of discrete and separate shapes are often small enough relative the radius of the bonding roller that the bonding surface may appear flat/planar; and the bonding surface shape area is closely approximated by a planar area of the same shape. A bonding

protrusion may have sides that are perpendicular to the bonding surface, although usually the sides have an angled slope, such that the cross section of the base of a bonding protrusion is larger than its bonding surface. A plurality of bonding protrusions may be arranged on a calender roller in a pattern. The plurality of bonding protrusions has a bonding area per unit surface area of the outer cylindrical surface which can be expressed as a percentage, and is the ratio of the combined total of the bonding shape areas of the protrusions within the unit, to the total surface area of the unit.

A "row" of bonds on a nonwoven web is a group of nearest neighboring bonds of like shape and rotational orientation that are arranged along the line that extends most predominately in the cross direction.

"Substantially cellulose free" is used herein to describe an article, such as an absorbent core, that contains less than 10% by weight cellulosic fibers, less than 5% cellulosic fibers, less than 1% cellulosic fibers, no cellulosic fibers, or no more than an immaterial amount of cellulosic fibers. An immaterial amount of cellulosic material would not materially affect the thinness, flexibility, or absorbency of an absorbent core.

"Substantially continuously distributed" as used herein indicates that within the absorbent particulate polymer material area, the first substrate 64 and second substrate 72 are separated by a multiplicity of superabsorbent particles. It is recognized that there may be minor incidental contact areas between the first substrate 64 and second substrate 72 within the absorbent particulate polymer material area. Incidental contact areas between the first substrate 64 and second substrate 72 may be intentional or unintentional (*e.g.* manufacturing artifacts) but do not form geometries such as pillows, pockets, tubes, and the like.

"Tensile Strength" refers to the maximum tensile force (Peak Force) a material will sustain before tensile failure, as measured by the Tensile Strength Measurement Method set forth herein.

"Thickness" and "caliper" are used herein interchangeably.

"Total Stiffness" refers to the measured and calculated value relating to a material, according to the Stiffness measurement method set forth herein.

"Volume mass" is the ratio of basis weight and thickness and indicates the bulkiness and fluffiness of the product, which are important properties of the nonwoven web according to the invention. The lower the value, the bulkier is the web.

$$\text{Volume mass [kg/m}^3\text{]} = \text{basis weight [g/m}^2\text{]} / \text{thickness [mm]}.$$

“Width” or a form thereof, with respect to a diaper or training pant, refers to a dimension measured along a direction parallel to the waist edges and/or perpendicular to the longitudinal axis.

“Z-direction,” with respect to a web, means generally orthogonal or perpendicular to the plane approximated by the web along the machine and cross direction dimensions.

Examples of the present invention include disposable absorbent articles having improved softness attributes.

Fig. 1A is a perspective view of a diaper 10 in a relaxed, laid-open position as it might appear opened and lying on a horizontal surface. Fig. 1B is a plan view of a diaper 10 shown in a flat-out, uncontracted state (*i.e.*, without elastic induced contraction), shown with portions of the diaper 10 cut away to show underlying structure. The diaper 10 is depicted in Fig. 1B with its longitudinal axis 36 and its lateral axis 38. Portions of the diaper 10 that contact a wearer are shown oriented upwards in Fig. 1A, and are shown facing the viewer in Fig. 1B. Fig. 2A is a cross section of the diaper taken at line 2-2 in Fig. 1B.

The diaper 10 generally may comprise a chassis 12 and an absorbent core 14 disposed in the chassis. The chassis 12 may comprise the main body of the diaper 10.

The chassis 12 may include a topsheet 18, which may be liquid pervious, and a backsheet 20, which may be liquid impervious. The absorbent core 14 may be encased between the topsheet 18 and the backsheet 20. The chassis 12 may also include side panels 22, elasticized leg cuffs 24, and an elastic waist feature 26. The chassis 12 may also comprise a fastening system, which may include at least one fastening member 46 and at least one landing zone 48. One or more layers of the topsheet and/or backsheet may be formed of a nonwoven web as described below.

The leg cuffs 24 and the elastic waist feature 26 may each typically comprise elastic members 28. One end portion of the diaper 10 may be configured as a first waist region 30 of the diaper 10. An opposite end portion of the diaper 10 may be configured as a second waist region 32 of the diaper 10. An intermediate portion of the diaper 10 may be configured as a crotch region 34, which extends longitudinally between the first and second waist regions 30 and 32. The crotch region 34 may include from 33.3% to 50% of the overall length of the diaper 10, and each of waist regions 30, 32 may correspondingly include from 25% to 33.3% of the overall length of the diaper 10.

The waist regions 30 and 32 may include elastic elements such that they gather about the waist of the wearer to provide improved fit and containment (elastic waist feature 26). The crotch

region 34 is that portion of the diaper 10 which, when the diaper 10 is worn, is generally positioned between the wearer's legs.

The diaper 10 may also include such other features including front and rear ear panels, waist cap features, elastics and the like to provide better fit, containment and aesthetic characteristics. Such additional features are described in, *e.g.*, U.S. Pats. Nos. 3,860,003 and 5,151,092.

In order to apply and keep diaper 10 in place about a wearer, the second waist region 32 may be attached by the fastening member 46 to the first waist region 30 to form leg opening(s) and an article waist. When fastened, the fastening system carries a tensile load around the article waist.

According to some examples, the diaper 10 may be provided with a re-closable fastening system or may alternatively be provided in the form of a pant-type diaper. When the absorbent article is a diaper, it may comprise a re-closable fastening system joined to the chassis for securing the diaper to a wearer. When the absorbent article is a pant-type diaper, the article may comprise at least two side panels joined to the chassis and to each other to form a pant. The fastening system and any component thereof may include any material suitable for such a use, including but not limited to plastics, films, foams, nonwoven, woven, paper, laminates, stretch laminates, activated stretch laminates, fiber reinforced plastics and the like, or combinations thereof. In some examples, the materials making up the fastening device may be flexible. In some examples, the fastening device may comprise cotton or cotton-like materials for additional softness or consumer perception of softness. The flexibility may allow the fastening system to conform to the shape of the body and thus, reduce the likelihood that the fastening system will irritate or injure the wearer's skin.

For unitary absorbent articles, the chassis 12 and absorbent core 14 may form the main structure of the diaper 10 with other features added to form the composite diaper structure. While the topsheet 18, the backsheet 20, and the absorbent core 14 may be assembled in a variety of well-known configurations, preferred diaper configurations are described generally in U.S. Pat. No. 5,554,145 entitled "Absorbent Article With Multiple Zone Structural Elastic-Like Film Web Extensible Waist Feature" issued to Roe et al. on Sep. 10, 1996; U.S. Pat. No. 5,569,234 entitled "Disposable Pull-On Pant" issued to Buell et al. on Oct. 29, 1996; and U.S. Pat. No. 6,004,306 entitled "Absorbent Article With Multi-Directional Extensible Side Panels" issued to Robles et al. on Dec. 21, 1999.

The topsheet 18 may be fully or partially elasticized and/or may be foreshortened to create a void space between the topsheet 18 and the absorbent core 14. Exemplary structures including elasticized or foreshortened topsheets are described in more detail in U.S. Pat. No. 5,037,416 entitled "Disposable Absorbent Article Having Elastically Extensible Topsheet" issued to Allen et al. on Aug. 6, 1991; and U.S. Pat. No. 5,269,775 entitled "Trisection Topsheets for Disposable Absorbent Articles and Disposable Absorbent Articles Having Such Trisection Topsheets" issued to Freeland et al. on Dec. 14, 1993.

The backsheet 20 may be joined with the topsheet 18. The backsheet 20 may serve to prevent the exudates absorbed by the absorbent core 14 and contained within the diaper 10 from soiling other external articles that may contact the diaper 10, such as bed sheets and clothing. Referring to Fig. 2B, the backsheet 20 may be substantially impervious to liquids (*e.g.*, urine) and may be formed of a laminate of a nonwoven 21 and a thin polymeric film 23 such as a thermoplastic film having a thickness of about 0.012 mm (0.5 mil) to about 0.051 mm (2.0 mils). Nonwoven 21 may be a nonwoven web as described herein. Suitable backsheet films include those manufactured by Tredegar Industries Inc. of Terre Haute, Ind. and sold under the trade names X15306, X10962, and X10964. Other suitable backsheet materials may include breathable materials that permit vapors to escape from the diaper 10 while still preventing liquid exudates from passing through the backsheet 20. Exemplary breathable materials may include materials such as woven webs, nonwoven webs, composite materials such as film-coated nonwoven webs, and microporous films such as manufactured by Mitsui Toatsu Co., of Japan under the designation ESPOIR and by EXXON Chemical Co., of Bay City, Texas, under the designation EXXAIRE. Suitable breathable composite materials comprising polymer blends are available from Clopay Corporation, Cincinnati, Ohio under the name HYTREL blend Pl 8-3097. Other examples of such breathable composite materials are described in greater detail in PCT Application No. WO 95/16746, published on Jun. 22, 1995 in the name of E. I. DuPont. Other breathable backsheets including nonwoven webs and apertured formed films are described in U.S. Pat. No. 5,571,096 issued to Dobrin et al. on Nov. 5, 1996.

In some examples, the backsheet of the present invention may have a water vapor transmission rate (WVTR) of greater than about 2,000 g/24h/m², greater than about 3,000 g/24h/m², greater than about 5,000 g/24h/m², greater than about 6,000 g/24h/m², greater than about 7,000 g/24h/m², greater than about 8,000 g/24h/m², greater than about 9,000 g/24h/m², greater than about 10,000 g/24h/m², greater than about 11,000 g/24h/m², greater than about

12,000 g/24h/m², greater than about 15,000 g/24h/m², measured according to WSP 70.5 (08) at 37.8 °C and 60% Relative Humidity.

Suitable nonwoven web materials useful in the present invention include, but are not limited to spunbond, meltblown, spinnmelt, solvent-spun, electrospun, carded, film fibrillated, melt-film fibrillated, air-laid, dry-laid, wet-laid staple fibers, and other and other nonwoven web materials formed in part or in whole of polymer fibers, as known in the art. A suitable nonwoven web material may also be an SMS material, comprising a spunbonded, a melt-blown and a further spunbonded stratum or layer or any other combination of spunbonded and melt-blown layers, such as a SMMS or SSMMS etc. Examples include one or more layers of fibers with diameters below 1 micron (nanofibers and nanofiber layers); examples of these rise in combinations of SMS, SMNS, SSMNS or SMNMS nonwoven webs (where "N" designates a nanofiber layer). In some examples, permanently hydrophilic non-wovens, and in particular, nonwovens with durably hydrophilic coatings may be desirable. Typically, the suitable non-woven is air permeable. Typically the suitable nonwoven is water or liquid permeable, but may also be water impermeable by reason of fiber size and density, and hydrophobicity of the fibers. Water or liquid permeability may be enhanced by treatments to render the fibers hydrophilic, as discussed below.

The nonwoven web may be formed predominately of polymeric fibers. In some examples, suitable non-woven fiber materials may include, but are not limited to polymeric materials such as polyolefins, polyesters, polyamide, or specifically polypropylene (PP), polyethylene (PE), poly-lactic acid (PLA), polyethylene terephthalate (PET) and/or blends thereof. Nonwoven fibers may be formed of, or may include as additives or modifiers, components such as aliphatic polyesters, thermoplastic polysaccharides, or other biopolymers (bio-based or renewable polymers).

The individual fibers may be monocomponent or multicomponent. The multicomponent fibers may be bicomponent, such as in a core-and-sheath or side-by-side arrangement. Often, the individual components comprise aliphatic polyolefins such as polypropylene or polyethylene, or their copolymers, aliphatic polyesters, thermoplastic polysaccharides or other biopolymers.

Further useful nonwovens, fiber compositions, formations of fibers and nonwovens and related methods are described in U.S. Pat. No. 6,645,569 to Cramer et al., U.S. Pat. No. 6,863,933 to Cramer et al., U.S. Pat. No. 7,112,621 to Rohrbaugh et al.; co-pending U.S. patent application Ser. Nos. 10/338,603 and 10/338,610 by Cramer et al., and 13/005,237 by Lu et al., the disclosures of which are incorporated by reference herein.

Some polymers used for nonwoven fiber production may be inherently hydrophobic, and for certain applications they may be surface treated or coated with various agents to render them hydrophilic. A surface coating may include a surfactant coating. One such surfactant coating is available from Schill & Silacher GmbH, Böblingen, Germany, under the Tradename Silastol PHP 90.

Another way to produce nonwovens with durably hydrophilic coatings, is via applying a hydrophilic monomer and a radical polymerization initiator onto the nonwoven, and conducting a polymerization activated via UV light resulting in monomer chemically bound to the surface of the nonwoven as described in co-pending U.S. Patent Publication No. 2005/0159720.

Another way to produce hydrophilic nonwovens made predominantly from hydrophobic polymers such as polyolefins is to add hydrophilic additives into the melt prior to extrusion.

Another way to produce nonwovens with durably hydrophilic coatings is to coat the nonwoven with hydrophilic nanoparticles as described in co-pending applications U.S. Pat. No. 7,112,621 to Rohrbaugh et al. and in PCT Application Publication WO 02/064877.

Typically, nanoparticles have a largest dimension of below 750 nm. Nanoparticles with sizes ranging from 2 to 750 nm may be economically produced. An advantage of nanoparticles is that many of them can be easily dispersed in water solution to enable coating application onto the nonwoven, they typically form transparent coatings, and the coatings applied from water solutions are typically sufficiently durable to exposure to water. Nanoparticles can be organic or inorganic, synthetic or natural. Inorganic nanoparticles generally exist as oxides, silicates, and/or carbonates. Typical examples of suitable nanoparticles are layered clay minerals (*e.g.*, LAPONITE™ from Southern Clay Products, Inc. (USA), and Boehmite alumina (*e.g.*, Disperal P2™ from North American Sasol. Inc.). According to one example, a suitable nanoparticle coated non-woven is that disclosed in the co-pending patent application Ser. No. 10/758,066 entitled "Disposable absorbent article comprising a durable hydrophilic core wrap" by Ponomarenko and Schmidt.

In some cases, the nonwoven web surface can be pre-treated with high energy treatment (corona, plasma) prior to application of nanoparticle coatings. High energy pre-treatment typically temporarily increases the surface energy of a low surface energy surface (such as PP) and thus enables better wetting of a nonwoven by the nanoparticle dispersion in water.

Notably, hydrophilic non-wovens are also useful in other parts of an absorbent article. For example, topsheets and absorbent core layers comprising permanently hydrophilic non-wovens as described above have been found to work well.

A nonwoven also may include other types of surface coating. In one example, the surface coating may include a fiber surface modifying agent that reduces surface friction and enhances tactile lubricity. Preferred fiber surface modifying agents are described in U.S. Pat. Nos. 6,632,385 and 6,803,103; and U.S. Pat. App. Pub. No. 2006/0057921.

According to one example, the nonwoven may comprise a material that provides good recovery when external pressure is applied and removed. Further, according to one example, the nonwoven may comprise a blend of different fibers selected, for example from the types of polymeric fibers described above. In some embodiments, at least a portion of the fibers may exhibit a spiral curl which has a helical shape. According to one example, the fibers may include bicomponent fibers, which are individual fibers each comprising different materials, usually a first and a second polymeric material. It is believed that the use of side-by-side bi-component fibers is beneficial for imparting a spiral curl to the fibers.

In order to enhance softness perceptions of the absorbent article, nonwovens forming the backsheet may be hydroenhanced or hydroengorged. Hydroenhanced/hydroengorged nonwovens are described in U.S. Pat. Nos. 6,632,385 and 6,803,103, and U.S. Pat. App. Pub. No. 2006/0057921, the disclosures of which are incorporated herein by reference.

A nonwoven may also be treated by a "selfing" mechanism. By "selfing" nonwovens, high densities of loops (>150 in 2) may be formed which protrude from the surface of the nonwoven substrate. Since these loops act as small flexible brushes, they create an additional layer of springy loft, which may enhance softness. Nonwovens treated by a selfing mechanism are described in U.S. Pat. App. Pub. No. US 2004/0131820.

Any of the nonwoven types described herein may be used for the topsheet, backsheet outer layer, loops component in a hook-and-loop fastening system of an absorbent article, or any other portion of a manufactured article such as cleansing wipes and other personal hygiene products, dusters and dusting cloths, household cleaning cloths and wipes, laundry bags, dryer bags and sheets comprising a layer formed of nonwoven web.

The absorbent core generally may be disposed between the topsheet 18 and the backsheet 20. It may include one or more layers, such as a first absorbent layer 60 and a second absorbent layer 62.

The absorbent layers 60, 62 may include respective substrates 64, 72, an absorbent particulate polymer material 66, 74 disposed on substrates 64, 72, and a thermoplastic adhesive material 68, 76 disposed on and/or within the absorbent particulate polymer material 66, 74 and

at least portions of the substrates 64, 72 as an adhesive for immobilizing the absorbent particulate polymer material 66, 74 on the substrates 64, 65.

The substrate 64 of the first absorbent layer 60 may be referred to as a dusting layer and has a first surface which faces the backsheet 20 and a second surface which faces the absorbent particulate polymer material 66. Likewise, the substrate 72 of the second absorbent layer 62 may be referred to as a core cover and has a first surface facing the topsheet 18 and a second surface facing the absorbent particulate polymer material 74.

The first and second substrates 64 and 72 may be adhered to one another with adhesive about the periphery to form an envelope about the absorbent particulate polymer materials 66 and 74 to hold the absorbent particulate polymer material 66 and 74 within the absorbent core 14.

The substrates 64, 72 may be of one or more nonwoven materials, and may be liquid permeable.

As illustrated in Fig. 2A, the absorbent particulate polymer material 66, 74 may be deposited on the respective substrates 64, 72 in clusters 90 of particles to form a grid pattern comprising land areas 94 and junction areas 96 between the land areas 94. Land areas 94 are areas where the thermoplastic adhesive material does not contact the nonwoven substrate or the auxiliary adhesive directly; junction areas 96 are areas where the thermoplastic adhesive material does contact the nonwoven substrate or the auxiliary adhesive directly. The junction areas 96 in the grid pattern contain little or no absorbent particulate polymer material 66 and 74. The land areas 94 and junction areas 96 can have a variety of shapes including, but not limited to, circular, oval, square, rectangular, triangular, and the like. First and second layers 60, 62 may be combined to form the absorbent core 14. Preferred absorbent articles and cores are described in U.S. Application Serial No. 12/141,122; U.S. Pat. Apps. Pub. Nos. 2004/0167486A1 and 2004/0162536; and PCT Pub. No. WO 2009/060384.

Signal ingredients may be incorporated into one or more components of the absorbent article. Signal ingredients may include, but are not limited to, vitamins A, E, D, and C, panthenol, niacin, omega 3 oils, cocoa butter, beeswax, cashmere, sweet almond oil, jojoba, oatmeal, aloe, cotton, honey, and silk. These signal ingredients may be added to an absorbent article for the purpose of signaling a benefit to the consumer. As an example, one or more of these signal ingredients may be added to a lotion that may be applied to an absorbent article component. The signal ingredient alone, or in a lotion, may be applied to the topsheet, backsheet, or any other component of the absorbent article. The lotion may comprise less than about 0.1% by weight, less than about 0.01% by weight, less than about 0.006% by weight, less

than about 0.005% by weight, less than about 0.004% by weight, less than about 0.003% by weight, less than about 0.002% by weight, and less than about 0.001% by weight of the signal ingredient.

Additionally, a signal ingredient may, in combination with other absorbent article features, result in an unexpected synergy for communicating a benefit to the consumer. As an example, consumers may respond unexpectedly more favorably to an absorbent article that is thin and perceptibly soft in combination with a communication that lotion in the diaper comprises vitamin E than they would respond to either communication on its own.

An example of a diaper lotion comprising vitamin E as a signal ingredient may include the following formula: PET/StOH Mix (ratio=1.41) 94.0% to 99.8% (by weight) Aloe Extract 0.1% to 3.0% (by weight) Vitamin E 0.00 1% to 0.1% (by weight). Further, vitamin E may be used in its natural form or esters of natural vitamin E may be used (*e.g.*, vitamin E acetate). U.S. App. Pub. Nos. 2002/0143304; 2004/0175343; 2003/0077307; U.S. Patent Nos. 5,643,588; 5,635,191; 5,607,760; 6,861,571; and PCT Application Nos. WO 00/69481; and WO 98/24391 disclose various absorbent article lotions that signal ingredients may be added to.

The foregoing description describes features of an absorbent article, any combination of which can be employed to enhance consumer perceptions of softness of the article. In addition, however, it is believed that manufacturing a nonwoven web, and using it as a component of an absorbent article including, *e.g.*, a topsheet 18 and/or backsheet 20 (*see* Figs. 2A, 2B), according to the following description, provides for enhancement of loft of the component, and has synergistic effects with respect to enhancing perceptions of softness of the article as a whole. At the same time, counterintuitively, features described below may enhance tensile strength of the nonwoven web, and consequently, of the topsheet, backsheet or other component formed of it. When attempting to improve softness signals, preserving or enhancing tensile strength of a nonwoven may be of particular interest in absorbent articles for at least two reasons. First, the nonwoven web may typically be required to sustain certain minimum tensile forces and undergo sufficiently low changes in dimension so as to be effectively processable in downstream manufacturing operations. Second, the nonwoven web typically may be a substantial contributor to structural integrity of a the manufactured product, such as a disposable diaper, in which the backsheet may be required to sustain forces resulting from application/donning on a wearer (*e.g.*, when a caregiver tugs on fastening members to apply a diaper), wearer movements, and weight and bulk contained and sustained by the backsheet when the diaper is loaded with the wearer's exudates.

As previously noted, referring to Fig. 2B, a backsheet 20 may be formed of a laminate of a nonwoven 21 and a thin polymeric film 23. The nonwoven and film may be bonded in the laminating process by adhesive or any other suitable means. In some examples, the polymeric film may have a thickness of about 0.012 mm (0.5 mil) to about 0.051 mm (2.0 mils). In order to achieve the desired overall visual appearance, the opacity and whiteness of the backsheet laminate may be enhanced by addition of, for example, calcium carbonate (CaCO_3) to the film during its formation. Inclusion of fine particles of CaCO_3 cause the formation of micropores about the particles upon stretching, or biaxial stretching in processing of the film, which serve to make the resulting film air- and vapor-permeable (thus, “breathable”, reducing the likelihood of skin overhydration and thereby reducing the likelihood of conditions such as diaper rash). The CaCO_3 particles and the resulting micropores in the film also serve to enhance its opacity. Examples of suitable films include MICROPRO microporous films, and films designated BR137P and BR137U, available from Clopay Corporation, Mason, Ohio. In some examples, the polymeric film may be formed of components, and as described, in U.S. application Pub. No. 2008/0306463, and may include some or all of the features and/or components described therein, that reduce the film’s vulnerability to glue “burn-through.”

The nonwoven 21 may be formed from one or more resins of polyolefins, polyesters, polyamide including but not limited to polypropylene (PP), polyethylene (PE), and polyethylene terephthalate (PET), poly-lactic acid (PLA), and blends thereof. Resins including polypropylene may be particularly useful because of polypropylene’s relatively low cost and surface friction properties of fibers formed from it (*i.e.*, they have a relatively smooth, slippery tactile feel). Resins including polyethylene may also be desirable because of polyethylene’s relative softness/pliability and even more smooth/slippery surface friction properties. Relative each other, PP currently has a lower cost and fibers formed from it have a greater tensile strength, while PE currently has a greater cost and fibers formed from it have a lower tensile strength but greater pliability and a more smooth/slippery feel. Accordingly, it may be desirable to form nonwoven web fibers from a blend of PP and PE resins, finding a balance of the best proportions of the polymers to balance their advantages and disadvantages. In some examples, the fibers may be formed of PP/PE blends such as described in U.S. Pat. No. 5,266,392. Nonwoven fibers may be formed of, or may include as additives or modifiers, components such as aliphatic polyesters, thermoplastic polysaccharides, or other biopolymers.

The individual fibers may be monocomponent or multicomponent. The multicomponent fibers may be bicomponent, such as in a core-and-sheath or side-by-side arrangement. Often, the

individual components comprise aliphatic polyolefins such as polypropylene or polyethylene, or their copolymers, aliphatic polyesters, thermoplastic polysaccharides or other biopolymers.

A batt may be formed from any of these resins by conventional methods, such as carding, meltblowing, spunlaying, airlaying, wet-laying etc. A preferred execution relates to spunbonding processes, in which the resin(s) are heated and forced under pressure through spinnerets. The spinnerets eject fibers of the polymer(s), which are then directed onto a moving belt; as they strike the moving belt they may be laid down in somewhat random orientations, but often with a machine-direction orientation or bias, to form a spunlaid batt. The batt then may be calender-bonded to form the nonwoven web.

Nonwovens formed of any basis weight may be used. However, as noted in the background, relatively higher basis weight, while having relatively greater apparent caliper and loft, also has relatively greater cost. On the other hand, relatively lower basis weight, while having relatively lower cost, adds to the difficulty of providing a backsheet that has and sustains a dramatic visual 3-dimensional appearance following compression in a package, and has suitable mechanical properties. It is believed that the combination of features described herein strikes a good balance between controlling material costs while providing a dramatic visual 3-dimensional appearance and suitable mechanical properties. It is believed that the features of consolidating bond shapes and patterns described herein may be particularly useful in applications of nonwovens of relatively low basis weights in some applications, in that it is believed that such features provide a way to enhance loft while reducing, or at least without adding, basis weight. Accordingly, for such applications, a nonwoven having a basis weight from 6.0 to 50 gsm, more preferably from 8.0 to 35 gsm, even more preferably from 9.0 to 25 gsm, and still more preferably from 10 to 20 gsm may be used. When used as a component of an absorbent article such as a topsheet, a lower basis weight nonwoven may provide strikethrough superior to that of a higher basis weight nonwoven. A lower basis weight nonwoven may be preferable to a higher basis weight one when used, for example, as a component of a zero-strain stretch laminate, because it will be more accommodating of an activation/incremental stretching process. In other applications, such as, for example, use of nonwovens to form products such as disposable clothing articles, wipes or dusters, higher basis weights up to 100 gsm, or even 150 gsm, may be desired. It is believed that the features of bonding protrusions, bonding shapes and bonding patterns described herein may have beneficial effects on loft and/or softness perception, even with nonwovens of such higher basis weights. Optimal basis weight is dictated by the differing needs in each application, and cost concerns.

It is believed that the desired overall visual softness signals of a backsheet laminate may be better achieved when the backsheet laminate is substantially white in color, and has an Opacity of at least 45%, more preferably at least 70%, even more preferably at least 73%, and still more preferably at least 75%, as measured by the Opacity Measurement Method set forth below. Accordingly, it may be desirable to add a white-tinting/opacifying agent also to the polymer(s) forming the polymeric film, and to the polymer(s) supplying the spinnerets used to form the fibers of the nonwoven web.

It may be desirable that a white-tinting/opacifying agent be added to the polymer resin that is spun to make the nonwoven. Adjusting the opacity of the nonwoven web, through addition of an opacifying agent, may be desirable, such that the nonwoven web has an Opacity of at least 10%, more preferably at least 18%, and still more preferably at least 40%.

While a variety of whitening/opacifying agents may suffice, it is believed that titanium dioxide (TiO_2) may be particularly effective because of its brightness and relatively high refractive index. It is believed that addition of TiO_2 to the polymer(s) from which the fibers are to be formed, in an amount up to 5.0% by weight of the nonwoven, may be effective to achieve the desired results. However, because TiO_2 is a relatively hard, abrasive material, inclusion of TiO_2 in amounts greater than 5.0% by weight may have deleterious effects, including wear and/or clogging of spinnerets; interruption and weakening of the structure of the fibers and/or calender bonds therebetween; undesirably increasing the surface friction properties of the fibers (resulting in a less smooth tactile feel); and unacceptably rapid wear of downstream processing equipment components. It is believed that the increased opacity provided by whitener helps to produce a visually distinctive, soft appearance of the nonwoven. It also may be desired in some applications that a coloring or tinting agent be added to one or more the polymer resin(s) from which the nonwoven fibers will be spun.

Opacity can also be enhanced by using fiber having cross-sectional shapes other than round and solid (non-hollow) geometries, namely trilobal or multilobal cross-sections, or hollow configurations or combinations thereof. Those non-circular cross-sectional shapes can also provide advantages in terms of loft and compression resilience.

Spunbonding includes the step of calender-bonding the batt of spunlaid fibers, to consolidate them and bond them together to some extent to create the web as a fabric-like structure and enhance mechanical properties *e.g.*, tensile strength, which may be desirable so the material can sufficiently maintain structural integrity and dimensional stability in subsequent manufacturing processes, and in the final product in use. Referring to Fig. 3, calender-bonding

may be accomplished by passing the batt 21a through the nip between a pair of rotating calender rollers 50, 51, thereby compressing and consolidating the fibers to form a nonwoven web 21. One or both of the rollers may be heated, so as to promote heating, plastic deformation, intermeshing and/or thermal bonding/fusion between superimposed fibers compressed at the nip. The rollers may form operable components of a bonding mechanism in which they are urged together by a controllable amount of force, so as to exert the desired compressing force/pressure at the nip. In some processes an ultrasonic energy source may be included in the bonding mechanism so as to transmit ultrasonic vibration to the fibers, again, to generate heat energy within them and enhance bonding.

One or both of the rollers may have their circumferential surfaces machined, etched, engraved or otherwise formed to have thereon a bonding pattern of bonding protrusions and recessed areas, so that bonding pressure exerted on the batt at the nip is concentrated at the bonding surfaces of the bonding protrusions, and is reduced or substantially eliminated at the recessed areas. The bonding surfaces have bonding surface shapes. As a result, an impressed pattern of bonds between fibers forming the web, having bond impressions and bond shapes corresponding to the pattern and bonding surface shapes of the bonding protrusions on the roller, is formed on the nonwoven web. One roller such as roller 51 may have a smooth, unpatterned cylindrical surface so as to constitute an anvil roller, and the other roller 50 may be formed with a pattern as described, to constitute a bonding pattern roller; this combination of rollers will impart a pattern on the web reflecting the pattern on the bonding pattern roller. In some examples both rollers may be formed with patterns, and in particular examples, differing patterns that work in combination to impress a combination pattern on the web such as described in, for example, U.S. Pat. No. 5,370,764.

A repeating pattern of bonding protrusions and recessed areas such as, for example, depicted in Fig. 4A, may be formed onto a bonding roller 50 (Fig. 3). The rod-shaped bonding shapes 100 depicted in Fig. 4A depict raised surfaces of bonding protrusions on a roller, while the areas between them represent recessed areas 101. The bonding shapes 100 of the bonding protrusions impress like-shaped bond impressions on the web in the calendering process.

The bonding protrusions on a roller will have a height, which may be expressed as a difference between the radius of the roller at the outermost (bonding) surfaces of the bonding protrusions, and the radius of the roller at the recessed areas 101. The height may be adjusted with the objective of minimizing the amount of material that must be removed from the roller surface by machining or etching to create the desired shapes and pattern, while still providing for

sufficient clearance between the roller bearing the bonding protrusions and the opposing roller, at the recessed areas 101, to accommodate passage of the batt through the nip in areas of the batt not to be bonded (*i.e.*, at the recessed areas), without substantially compressing it – because maximum loft/caliper is the objective. For webs of the type and basis weight contemplated herein, a bonding protrusion height between 0.3 mm and 1.0 mm may be desired, or more preferably, a bonding protrusion height between 0.5 mm and 0.8 mm, or even a bonding protrusion height between 0.6 mm and 0.7 mm. The bonding surfaces of the bonding protrusions may have an average area between 0.3 mm² and 10 mm². The bonding protrusions typically have sides with an angled slope when viewed in cross section through the height thereof.

Nonwoven webs of the type contemplated herein may be calender-bonded at line speed greater than 300 m/min., or 600 m/min., or even 800 m/min., or more, depending upon nonwoven web composition, basis weight, bonding pattern, and equipment and process variables selected. Referring again to Fig. 3, it will be appreciated that at such speeds, the batt 21a and the surfaces of rollers 50, 51 will entrain surrounding air and move it toward the nip 52, as suggested by the arrows. Surface features of a bonding roller 50, as described above, will enhance this effect. It is believed that, as entrained air is carried toward the nip, the decreasing space between the rollers as the nip is approached creates a zone of relatively higher, and increasing, air pressure in front of the nip 52. A portion of the entrained air under such higher pressure will be urged into and further compressed in the nip 52, within the recessed areas of the bonding pattern on the roller, and within the interstices of the fibers passing through the nip. It is believed that, as nonwoven web 21 exits the nip 52, compressed air entrained within the fibers and passing through the nip therewith encounters a zone of relatively lower pressure on the exit side, and accelerates away from the nip in all unobstructed directions as a result. Thus, it is believed that substantial air entrainment, air compression and complex air flows of relatively high velocity occur within and about the batt 21a and web 21 as a result of movement of the batt and rotation of the calender rollers in the calender-bonding process.

It is believed that surface features of a bonding roller including the bonding protrusions affect these air flows. Particularly at the nip, the profiles of bonding protrusions present obstructions to airflow, while the recessed areas between the bonding protrusions present passageways. Thus, it is believed that for certain configurations, shapes, and positions of bonding protrusions, as will be reflected in the bond impressions created in the web, rotational orientation(s) and repeating patterns of the bonding shapes can be selected and formed to have a beneficial effect on these air flows. It is believed, further, that patterns of bonding protrusions

having bonding surface shapes with certain features, reflected in the bonding surfaces and the cross sections of the protrusions along planes substantially parallel with the bonding surfaces, rotational orientations relative the plane approximated by the web surface, and spacing, may be employed to channel these air flows in a way that causes them to reposition the fibers during the calender bonding process, such as by teasing or fluffing the fibers, thus providing an enhanced calender-bonded nonwoven web having greater loft/caliper than a similar nonwoven web having other consolidated bond shapes and patterns, all other variables being the same.

Figs. 5A, 5B and 5C depict one example of a bonding pattern and bonding shapes that will be reflected in bond shapes of bond impressions in a nonwoven web. Bonding shapes 100 represent the shapes of bonding surfaces of bonding protrusions that may be imparted to a bonding roller by etching, machining or other methods. Such bonding protrusions on a bonding roller will impress bond impressions into a web, of like bond shapes, arranged in a like bonding pattern. Without intending to be bound by theory, it is believed that certain aspects and features of the depicted shapes and pattern may have the beneficial effect described above.

Referring to Fig. 5B, the bonding shape 100 has a greatest measurable length L , which is measured by identifying a shape length line 104 intersecting the perimeter of the shape at points of intersection that are the greatest distance apart that may be identified on the perimeter, *i.e.*, the distance between the two farthest-most points on the perimeter. The bonding shape 100 has a greatest measurable width W which is measured by identifying respective shape width lines 105a, 105b which are parallel to shape length line 104 and tangent to the shape perimeter at one or more outermost points that are most distant from shape length line 104 on either side of it, as reflected in Fig. 5b. It will be appreciated that, for some shapes (*e.g.*, a semicircle), one of shape width lines 105a, 105b may be coincident/colinear with shape length line 104. Greatest measurable width W is the distance between shape width lines 105a, 105b. Shapes within the scope of the present invention have an aspect ratio of greatest measurable length L to greatest measurable width W of at least 2.5, more preferably at least 2.7, and even more preferably at least 2.8. The bond shapes and sizes impressed on the nonwoven web will reflect and correspond with the bonding shapes 100 and sizes thereof on the roller.

Still referring to Fig. 5B, a bonding shape 100 may have a shape perimeter with a convex portion 102, lying on one side of the shape length line 104. Fig. 5B shows also that the convex portion may have a varying radius or radii. The varying radius/radii of the convex portion 102 may render the shape perimeter similar to the profile of the camber of an airfoil in cross section. Viewed another way, the cross-sectional profile of an airfoil has a convex portion and is

asymmetric about any line or axis that traverses the profile, which can be identified. The convex portion 102 may have a camber height CH measured as the distance between shape length line 104 and the shape width line 105b that is tangent to the convex portion 102. It is believed that, for maximum beneficial impact on airflow, it may be desirable that the ratio between camber height CH and greatest measurable length L be 0.30 or less, more preferably 0.25 or less, but greater than zero. It is believed that a bonding protrusion having a cross section along a plane parallel the bonding surface, fitting this description, repeated and arranged in a pattern, has beneficial effects on acceleration and deceleration of air through nonwoven fibers at and about the nip. Again, the bond shapes and sizes impressed on the nonwoven web will reflect and correspond with the bonding shapes and sizes on the roller.

The shape perimeter may have a convex portion with or without a varying radius on both sides of shape length line 104, such that it has the overall contour of an airfoil with symmetrical camber, in cross section. In another alternative, the shape perimeter may have a convex portion on one side of shape length line 104 and a straight portion on or on the other side of shape length line 104, such that it has the overall contour of an airfoil/aircraft wing with asymmetrical camber, in cross section. In another alternative, the shape perimeter may have a convex portion on one side of shape length line 104 and a concave portion 103 disposed substantially opposite the convex portion, as reflected in Fig. 5B, such that it has the overall contour of an airfoil/aircraft wing with asymmetrical camber and relatively high-loft, low-speed features, in cross section.

The extent of the concavity of concave portion 103 may be quantified by measuring the depth thereof, relative the greatest measurable length. The concavity depth D may be measured by identifying a shape concavity line 106 that is parallel with the shape length line 104 and tangent to the deepest point along the concave portion 103. The concavity depth D is the distance between the shape width line 105a facing the concavity and the shape concavity line 106. The extent of the concavity of concave portion 103 may be expressed as a ratio of concavity depth D to shape length L (hereinafter, "concavity depth ratio"). Although shapes that do not have a concave portion 103 are contemplated, it may be desirable that a bonding shape has a concave portion having a concavity depth ratio between 0.00 and 0.30, more preferably between 0.00 and 0.25, and even more preferably between 0.00 and 0.20. Again, the bond shapes and sizes impressed on the nonwoven web will reflect and correspond with the bonding shapes and sizes on the roller.

Whilst the explanation above refers to bonding protrusions and resulting consolidated bond shapes in the web, which have bonding shape/bond shape perimeters following "convex"

and/or “concave” (impliedly, smooth) curves, it may be appreciated that the effect may be substantially realized by approximating such smooth curves with chains of straight line segments. Accordingly, each of the terms “convex” and “concave” herein includes a portion of a shape perimeter formed of a chain of 5 or more straight line segments lying on one side of a shape length line and connected end-to-end, that is each a chord of a smooth convex or concave curve lying on one side of the shape length line, or portion of a curve lying on one side of the shape length line that does not include an inflection point.

Without intending to be bound by theory, it is believed that calender roller bonding protrusions having bonding shapes with one or more features as described above have aerodynamic effects on air flow in and about the nip, that cause acceleration and deceleration of air in and about the interstices of the nonwoven fibers in a way that repositions the fibers, and may effect teasing or fluffing, adding loft and caliper.

Additionally, the rotational orientations of the protrusions affect the orientations of the bonding protrusions at the nip, and it is believed that this has an impact. Bonding shapes 100 and the bonding protrusions supporting them may be arranged along an individual shape tilt angle relative the machine and cross directions. Without intending to be bound by theory, it is believed that the shape tilt angle should not exceed a certain amount for the bonding protrusion to have maximum beneficial effect on air flow. Referring again to Fig. 5B, the shape tilt angle α_T may be expressed as the smaller angle formed by the intersection of an axis along the machine direction 108 and the shape length line 104. It is believed, that the shape and the shape tilt angle have cooperating effects on the air flow. In the case of an asymmetric bonding shape, such as the described airfoil-like shape, it is believed that this asymmetric bonding shape is sufficient for effecting the desired changes in air flow. However, a rotational orientation with a tilt angle of more than zero may enhance the effect. With respect to a bonding shape that is not asymmetric, it is believed that the shape tilt angle α_T provides the desired effects on air flow, such that it then should not be less than 1 degree and should not exceed 40 degrees, more preferably, 30 degrees, and still more preferably, 20 degrees. It is believed that a shape tilt angle within this range effectively provides air flow through the nip, while at the same time, imparts cross-direction vector components to air flows through the nip. Conversely, a shape tilt angle greater than 40 degrees may create too much of an obstruction to air flow through the nip to have a beneficial effect, and even greater shape tilt angles combined with sufficient density of bonding protrusions may have the effect of creating enough obstruction at the nip to substantially divert airflow from the nip, *i.e.*, toward the sides of the bonding rollers, rather than through the nip. The bond shapes

and rotational orientations impressed on the nonwoven web will reflect and correspond with the bonding shapes and rotational orientations on the roller.

It is believed that air flows having cross-direction vector components flowing across or through the batt/web as it passes through and exits the nip may urge fibers in the cross-direction, helping add loft, caliper and/or cross direction tensile strength. It will be appreciated that the fibers of many nonwoven batts are laid down in the nonwoven web manufacturing process with a general machine direction orientation or bias, which tends to result in the finished web having relatively greater machine direction tensile strength, and relatively less cross direction tensile strength. Thus, any process that tends to impart some added cross-direction orientation to the fibers prior to bonding may be useful for increasing cross direction tensile strength, bringing about better balance between machine direction tensile strength and cross-direction tensile strength, and adding loft such as by repositioning of the fibers in the z-direction. It is believed that, for best results, it may be even more desirable that shape tilt angle α_T is between 5 degrees and 15 degrees, more preferably between 8 degrees and 12 degrees, and even more preferably between 9 degrees and 11 degrees, for the most beneficial effects on airflow at the line speeds contemplated herein. The rotational orientation of the bonding pattern impressed on the nonwoven web will reflect and correspond with the rotational orientation of the bonding pattern on the roller.

As suggested above, in order to gain the benefit of energy from a substantial mass of air flowing through the nip, it is also believed desirable that a pattern of bonding protrusions not be excessively obstructive of air flow through the nip, nor that it remove too much energy from the air flow by overly slowing, or halting, and absorbing the energy from, forward (machine-direction) momentum of air flows. Referring to Fig. 5C, a nip line 107a along the cross direction is identified along a pattern where the bonding shapes occupy the greatest proportion of distance along a cross direction line that can be identified in a pattern. Thus, nip line 107a located as shown represents a cross-direction line along which bonding protrusions presented the greatest amount of obstruction that can be identified in a particular pattern, to air flow through the nip, during the bonding process. A repeating series of shapes can be identified; in this example, the repeating series consists of the four shapes 100a, 100b, 100c and 100d. Widths w_1 , w_2 , w_3 , and w_4 of the identified shapes 100a, 100b, 100c, 100d in the repeating series reflect restriction of air flow along the nip line 107a. Width w_p is the width of the entire repeating series, including the distances between the bonding shapes. The proportion of maximum restriction along the nip length for the pattern is reflected by the ratio $(w_1 + w_2 + w_3 + w_4 \dots + w_n) / w_p$, referred to herein

as the nip airflow restriction ratio (where “w” is the cross-direction width along the nip line 107a of a bonding shape perimeter, and “n” is the number of bonding shapes along nip line 107a that make up a repeating series). In order that a bonding pattern allows for effective air flow through the nip in order to take advantage of energy of moving air, it may be desirable that the nip airflow restriction ratio be 0.40 or less, more preferably 0.30 or less, and even more preferably 0.25 or less. The bond shapes, rotational orientations and density/numerosity per unit surface area of bond impressions on the nonwoven web will reflect and correspond with the bonding shapes, rotational orientations and density/numerosity per unit surface area of bonding protrusions on the roller, and thus, also reflect the airflow restriction ratio.

Referring to Figs. 6A and 6B, an alternative bonding pattern is depicted. The repeated bonding shape 100 and profile of the associated bonding protrusion is a composite of two generally convex/concave sub-shapes joined or superimposed at their respective tips, in reversed orientation, to form an open “S” shape which is rotationally symmetric about this juncture of the component sub-shapes, respectively its middle inflection point. It will be appreciated, however, that the depicted repeated “S” shape may have several of the features of the bonding shape depicted in Figs. 5A and 5B, described above, which are believed to be beneficial. The depicted bonding shape 100 in Figs. 6A and 6B has a greatest measurable length L and greatest measurable width W, measured with respect to shape length line 104 and shape width lines 105a, 105b, identified in the manner described above. As set forth above, bonding shapes 100 within the scope of the present invention have an aspect ratio of greatest measurable length L to greatest measurable width W of at least 2.5, more preferably at least 2.7, and even more preferably at least 2.8.

The depicted bonding shape in Figs. 6A and 6B also has convex portions 102a, 102b along its perimeter. One or both of the convex portions 102a, 102b may have varying radii, and have camber heights CH_A and CH_B . It is believed that, for maximum beneficial impact on airflow, it may be desirable that the ratio between camber height CH and the greatest measurable length L also be 0.30 or less, more preferably 0.25 or less, but greater than zero.

The depicted bonding shape also has concave portions 103a and 103b along its perimeter. Concavity depth Da is the distance between shape width line 105a facing concavity 103a, and shape concavity line 106a. Concavity depth Db is the distance between shape width line 105b facing concavity 103b, and shape concavity line 106b. Although bonding shapes that do not have a concave portion 103a, 103b along their perimeters are contemplated, it may be desirable

that a bonding shape perimeter has one or more concave portions such as concave portions 103a, 103b having a concavity depth ratio:

Concavity depth $/(L*nc) \leq 0.30$, more preferably 0.25, and even more preferably 0.20, where nc is the number of fully enclosed shapes that are defined by portions of the bonding shape perimeter and the shape length line, which evidence concavities. For example, for the “S” shape shown in Fig. 6B, $nc = 2$ because there are 2 such fully enclosed shapes 124a and 124b.

The shapes 100 in Figs. 6A and 6B also may have a shape tilt angle α_T determined as set forth above, and within the ranges set forth. The geometric features of the bond shapes and pattern on the nonwoven web will reflect and correspond with those of the shape, size, rotational orientation, density and arrangement of the bond shapes 100.

It is also believed that arranging the bonding protrusions in a pattern such that a relatively straight, unobstructed passageway between them exists along recessed areas 101 at the nip, at least partially along the machine direction, may have beneficial effects. Referring to Figs. 5A and 6A, it can be seen that each example has a cross-nip airflow line 109 that can be identified, that intersects no bonding shape, and intersects a cross direction axis 107 at an angle such that it has a machine direction vector component. Cross-nip airflow line 109 intersects cross direction axis 107 to form a smaller angle, identified herein as cross-nip airflow angle β_A . It is believed that cross-nip airflow angle β_A is preferably greater than 45 degrees, more preferably between 50 degrees and 90 degrees, and even more preferably between 60 degrees and 90 degrees. It is believed desirable that cross-nip airflow line 109 should extend indefinitely without intersecting a bonding shape 100, but at a minimum, past at least 8 rows 110 of bonding shapes 100 without intersecting a bond shape. Again, geometric features of the bond shapes and pattern on the nonwoven web will reflect and correspond with those of the shape, size, rotational orientation, density and arrangement of the bond shapes 100.

Another aspect of the bonding shapes and patterns depicted in, *e.g.*, Figs. 5A-6B is that they may have any combination of the above-described aspect ratios, maximum nip airflow restriction ratio (0.40 or less), shape asymmetry, shape tilt angles, and other features, and may also reflect use of adjacent pairs of bonding protrusions that define air passageways through the nip that alternately narrow and widen, or converge and diverge, in the manner of a venturi. For example, referring again to Figs. 5A and 6A, two adjacent bond shapes 100a, 100b may be identified. Herein, “adjacent” means that at least portions of the perimeters of a pair of shapes face each other with no intervening shapes between them; and that the pair of shapes has machine-direction overlap. The pair of shapes has machine-direction overlap if one or more

cross-direction lines 107 that are tangent to and/or cross the perimeters of each of the shapes may be identified. A minimum passageway clearance line MC may be identified connecting the perimeters of the shapes 100a, 100b, at the location where the shortest measurable distance between the perimeters exists. The minimum passageway clearance line MC will necessarily meet the perimeter of each of the adjacent shapes where line MC is normal to the perimeter, and line MC identifies the point of greatest constriction of an air passageway between the shapes (*i.e.*, through the corresponding bonding protrusions) proximate and through the nip. A passageway line PL may be identified, perpendicular to the minimum passageway clearance line MC and lying between the adjacent shapes 100a, 100b.

The minimum passageway clearance line MC crosses and identifies a “venturi passageway” if the perimeter of each of the adjacent shapes 100a, 100b diverges away from the passageway line PL moving along the perimeter away from the minimum clearance line MC in both directions. It can be seen in Figs. 5A and 6A that adjacent shapes 100a, 100b embody this feature.

Without intending to be bound by theory, it is believed that such venturi passageways have the effect of causing localized zones of acceleration and deceleration, and increases and decreases in pressure, as well as turbulence, of air as it passes through the nip. It is believed that these effects serve to tease and/or fluff the fibers of the batt and web about the nip.

For purposes of downstream handling and manufacturing processes, it may be desirable to ensure that no line along the machine direction exists along the nonwoven web surface that is indefinitely long without intersecting a bond impression. This condition (indefinitely long machine direction strip of web without bonds) may result in relatively long lengths of unbonded fibers that may be prone to moving away from a cutting knife in downstream machine direction web slitting operations, resulting in a poorly defined or sloppy slit edge. Additionally, such long, unbonded fibers may also separate from a manufactured edge or slit edge of the web (fraying), which may cause other difficulties in downstream operations. To avoid this condition, it may be desirable to impart a pattern angle γ_P to the bonding pattern. Referring to Figs. 6A, pattern angle γ_P may be expressed as the smaller angle formed by the intersection of a line 111 connecting like points on repeating, similarly oriented shapes in columns 112, and a machine direction axis. To avoid the above-mentioned problems, it may be desirable that pattern angle γ_P be greater than 0 degrees. A pattern angle greater than 0 degrees will ensure that an indefinitely long machine direction strip of web without bonds will not exist. To avoid creating complications with respect to the air flow benefits of the pattern, however, it may be desirable to limit pattern angle γ_P to 4

degrees or less, more preferably 3 degrees or less, and even more preferably 2.5 degrees or less. Again, features of the bond pattern on the nonwoven web including pattern angle will reflect and correspond with those of the pattern and pattern angle γ_p on the roller.

The features described above apply to the shapes of bonding surfaces of bonding protrusions in a pattern on a bonding roller, and it will be understood that these features are impressed by the roller into the nonwoven batt to form bond impressions having bond shapes and bonds thereat, to form the calender-bonded nonwoven web. As impressed into a nonwoven web, the bonding shapes are reflected as bond shapes, and are identifiable, and measurable in the web, in laminates that include such nonwoven web as a composite layer, and in composite products made from such nonwoven web and/or such laminates.

An additional aspect that it believed important is bonding area of a roller, reflected in bond area on the web. Imagining a pattern of bonding surfaces having shapes reflected in Figs. 5A and 6A impressed on a surface of a nonwoven web, bonding area and bond area is the area occupied by the bonding shapes on the roller and bond shapes impressed on the surface of the web. In the field of nonwoven web manufacturing, bonding area is often expressed as a percentage, calculated as:

$$\text{Bonding Area \%} = \left[\frac{(\text{bonding area within a surface area unit})}{(\text{total surface area of the surface area unit})} \right] \times 100\%$$

The bonding area reflects the combination of bonding protrusion density (number of bonding protrusions per unit surface area) and average surface area of the bonding shapes 100 in the unit surface area. Thus, increasing the number of bonding protrusions and/or increasing the surface area of the individual bond shapes 100 increases the bonding area, and *vice versa*. It is believed that bonding area has an impact on the entrainment of air as well as the proportion of entrained air carried toward the nip, which will pass through the nip. If bonding area is relatively greater, this means that more and/or larger bonding protrusions are present at the nip point at any time to obstruct air flow through the nip; conversely, if bonding area is relatively less, this means that fewer and/or smaller bonding protrusions are present at the nip point at any time to obstruct air flow through the nip. Bond area has another effect as well. Increasing bond area increases the number and proportion of the fibers in the nonwoven web that are bonded together, and *vice versa*. Within a certain range of bond area, tensile strength of the nonwoven web in the machine and/or cross directions may be increased by increasing the bond area. However, bending stiffness of the nonwoven web may be correspondingly increased, and loft decreased –

compromising the soft feel and/or appearance of the nonwoven. In order to best realize the benefits of air flow, air compression and channeling believed to be occurring through use of the bond shapes described herein, enhancing loft, while still imparting satisfactory tensile properties to the web, it is believed that bonding area should be in the range of 4.0% and 18%, more preferably between 6 % and 16%, and even more preferably between about 8 % and 14%. At the line speeds contemplated herein, and relative to the bonding area, the average surface area per bonding shape affects bonding area and bonding protrusion density. It is believed desirable that the average bonding shape 100 surface area be in the range of 0.3 mm² and 10 mm². Correspondingly, it is believed desirable that the density of the bonding protrusions, and correspondingly, the impressed bond shapes, be between 0.4 bonding protrusions/cm² for bonding shape/bond shape area of 10 mm² at 4% bonding area and 60 bonding protrusions/cm² for bonding shape/bond shape area of 0.3 mm² at 18% bonding area. Similar calculations of bonding protrusion density and average bond shape surface area to arrive at the bond areas in the ranges set forth above, will be appreciated. The surface area and density of bond shapes impressed on the nonwoven web will reflect and correspond with those of the bonding shapes, and thus, the bond area on the web will reflect and correspond with the bonding area on the roller as well.

It is also believed that the speed of travel of the batt toward the bonding nip (batt line speed) is important. It will be appreciated that, if the batt line speed is too slow, air mass entrained by the batt as it approaches the nip will not have sufficient linear momentum to maintain a large enough zone of sufficiently elevated air pressure at the entry side effective to ensure that substantial air mass is urged through the nip, rather than being merely urged around the nip and the rollers along alternate pathways. Accordingly, it is believed that line speed at which the batt is conveyed toward the nip should be equal to or greater than 300 meters/minute, more preferably, equal to or greater than 600 meters/minute, and even more preferably, equal to or greater than 800 meters/minute.

It is believed that use of a calender roller having bonding patterns and bonding shapes as described herein take advantage of air flows resulting from entrainment of air along a moving nonwoven batt and calender rollers, and air compression, that occur during calender-bonding, in a way that causes the resulting nonwoven web to have enhanced loft and a soft feel. It is believed also that the bonding shapes need not be all of like kind or rotational orientation, but rather, that suitable combinations of differing shapes including bonding shapes having features as described herein, and optionally, in combination with other shapes, may be used and included.

Employment of the described features may reduce or eliminate a need for other loft enhancement processes, such as hydroengorgement or hydroentanglement – which may save costs of additional equipment and operation.

Examples

In following examples for the manufacture of nonwoven webs, if it is not defined differently, the batt was produced from 3 following spunbond beams on REICOFIL 4 technology, using the four different bonding patterns indicated:

Pattern “Wing-shape” (as depicted in Fig. 5)

- Bonding area percentage = 12.4%
- Bonding protrusions / $\text{cm}^2 = 3.1$
- Angle $\alpha_T = 10^\circ$
- Angle $\beta_A = 90^\circ$
- Angle $\gamma_P = 1^\circ$
- L = 6.2 mm
- W = 1.7 mm
- D = 0.9 mm
- CH = 1.4 mm
- Distance between beginning of repeating shapes in columns = 8 mm
- Distance between beginning of repeating shapes in rows = 8 mm
- Bonding protrusion height = 0.65 mm

Pattern “S-shape” (as depicted in Fig. 6)

- Bonding area percentage = 12.9%
- Bonding protrusions / $\text{cm}^2 = 1.5$
- Angle $\alpha_T = 10^\circ$
- Angle $\beta_A = 60^\circ$
- Angle $\gamma_P = 1^\circ$
- L = 12.2 mm
- W = 4.0 mm
- $D_A = 3.1$ mm
- $D_B = 3.1$ mm

- $CH_A = 1.9$ mm
- $CH_B = 2.1$ mm
- Distance between beginning of repeating shapes in columns = 11.4 mm
- Distance between beginning of repeating shapes in rows = 6.0 mm
- Bonding protrusion height = 0.65 mm

Pattern “**S-shape v2**” according to the invention (Fig. 7)

- Bonding area percentage = 13 %
- Bonding protrusions / $cm^2 = 2.4$
- Angle $\alpha_T = 10^\circ$
- Angle $\beta_A = 63^\circ$
- Angle $\gamma_P = 1^\circ$
- $L = 9.2$ mm
- $W = 3.0$ mm
- $D_A = 2.3$ mm
- $D_B = 2.3$ mm
- $CH_A = 1.3$ mm
- $CH_B = 1.6$ mm
- Distance between beginning of repeating shapes in columns (DRC) = 8.8 mm
- Distance between beginning of repeating shapes in rows (DRR) = 4.65 mm
- Bonding protrusion height = 0.75 mm

Comparative pattern “Standard bulky” described in patent application WO 2009/021473 (depicted in Fig. 4A).

- Bonding area percentage = 14.0%
- Bonding protrusions / $cm^2 = 9$
- Angle $\alpha_T = 0^\circ$
- Angle $\beta_{A1} = 90^\circ$
- Angle $\beta_{A2} = 55^\circ$
- Angle $\gamma_P = 0^\circ$
- $L = 3.4$ mm
- $W = 0.4$ mm
- $D = 0$ mm

- CH = 0.2 mm
- Distance between beginning of repeating shapes in columns = 5.6 mm
- Distance between beginning of repeating shapes in rows = 2.0 mm
- Bonding protrusion height = 0.7 mm

Comparative pattern “Standard” – (oval shape, depicted Figs. 4B, 4C)

- Bonding area percentage = 18.1%
- Bonding protrusions / cm² = 49.9
- Angle $\alpha_T = 60^\circ$
- Angle β_A – does not exist
- Angle $\gamma_P = 0^\circ$
- L = 0.9 mm
- W = 0.5 mm
- D – does not exist
- CH = 0.3 mm
- Distance between beginning of repeating shapes in columns = 1.5 mm
- Distance between beginning of repeating shapes in rows = 2.6 mm
- Bonding protrusion height = 0.6 mm

Certain parameter and test results for the examples are summarized in Table 1 herein below.

Example 1 – comparative standard bulky

The 12gsm spunmelt type nonwoven batt produced online in a continuous process from polypropylene (Mosten NB425 from Unipetrol), where monocomponent polypropylene filaments with a fibre diameter of 18-30 μm (1.5 to 2.5 den) are produced and subsequently collected on a moving belt. To increase strength a patterned calender is used consisting of a pair of heated rollers, where one roller has raised comparative pattern “Standard bulky” (Fig 4A). The temperature of the calender rollers (smooth roller / patterned roller) is 165°C/ 168°C and the pressure is 75 N/mm.

Example 2– comparative standard bulky

A 14 gsm spunmelt type nonwoven batt produced online in a continuous process from polypropylene (Mosten NB425 from Unipetrol), where monocomponent polypropylene filaments

with a fibre diameter of 18-30 μm are produced and subsequently collected on a moving belt. To increase strength a patterned calender is used consisting of a pair of heated rollers, where one roller has raised comparative pattern "Standard bulky" (Fig. 4A). The temperature of the calender rollers (smooth roller / patterned roller) is 165°C/168°C and the pressure is 75 N/mm.

Example 3 – comparative standard bulky

A 15 gsm spunmelt type nonwoven batt produced online in a continuous process from polypropylene (Mosten NB425 from Unipetrol), where monocomponent polypropylene filaments with a fibre diameter of 18-30 μm are produced and subsequently collected on a moving belt. To increase strength a patterned calender is used consisting of a pair of heated rollers, where one roller has raised comparative pattern "Standard bulky" (Fig. 4A). The temperature of the calender rollers (smooth roller / patterned roller) is 168°C/171°C and the pressure is 75 N/mm.

Example 4 – comparative standard bulky

A 17 gsm spunmelt type nonwoven batt produced online in a continuous process from polypropylene (Mosten NB425 from Unipetrol), where monocomponent polypropylene filaments with a fibre diameter of 18-30 μm are produced and subsequently collected on a moving belt. To increase strength a patterned calender is used consisting of a pair of heated rollers, where one roller has raised comparative pattern "Standard bulky" (Fig. 4A). The temperature of the calender rollers (smooth roller / patterned roller) is 168°C/171°C and the pressure is 75 N/mm.

Example 5 – comparative standard

A 15 gsm spunmelt type nonwoven batt produced online in a continuous process from polypropylene (Mosten NB425 from Unipetrol), where monocomponent polypropylene filaments with a fibre diameter of 18-30 μm are produced and subsequently collected on a moving belt. To increase strength a patterned calender is used consisting of a pair of heated rollers, where one roller has raised comparative pattern "Standard" (Fig. 4B). The temperature of the calender rollers (smooth roller / patterned roller) is 170°C/173°C and the pressure is 95 N/mm.

Example 6 – comparative standard

A 17 gsm spunmelt type nonwoven batt produced online in a continuous process from polypropylene (Mosten NB425 from Unipetrol), where monocomponent polypropylene filaments with a fibre diameter of 18-30 μm are produced and subsequently collected on a moving belt. To increase strength a patterned calender is used consisting of a pair of heated rollers, where one

roller has raised comparative pattern “Standard” (Fig. 4B). The temperature of the calender rollers (smooth roller / patterned roller) is 170°C/173°C and the pressure is 95 N/mm.

Example 7 - comparative standard

A 15 gsm spinnmelt type nonwoven batt, produced using a continuous online process from polypropylene (HH 450 FB from Borelais) and polylactic acid (Ingeo 6202D from NatureWorks), where first the bicomponent core/sheath type filaments are produced, where the core representing 80% is from polylactic acid and the sheath is from polypropylene. The individual filaments a fibre diameter of 18-40 µm are collected on a moving belt. The batt was produced on REICOFIL 3 technology from 1 beam.

To increase strength a patterned calender is used, that consist of a pair of heated rollers, where one roller has raised comparative pattern “Standard” (Fig. 4B). The temperature of the calender rollers (smooth roller / patterned roller) is 140°C/140°C and the pressure is 75 N/mm.

Example 8 - comparative standard

The 15 gsm spinnmelt type nonwoven batt produced online in a continuous process from a mixture of polypropylene (Mosten NB425 from Unipetrol) and copolymer (Vistamaxx 6102 from Exxon) in the weight ratio 81:19, where monocomponent polypropylene filaments with a fibre diameter of 20-40 µm are produced and subsequently collected on a moving belt. The batt was produced on REICOFIL 3 technology from 2 beams.

To increase strength a patterned calender is used consisting of a pair of heated rollers, where one roller has raised comparative pattern “Standard” (Fig. 4B). The temperature of the calender rollers (smooth roller / patterned roller) is 145°C/145°C and the pressure is 75 N/mm.

Example 9 – “S” shape

A 12 gsm spinnmelt type nonwoven batt produced online in a continuous process from polypropylene (Mosten NB425 from Unipetrol), where monocomponent polypropylene filaments with a fibre diameter of 18-30 µm are produced and subsequently collected on a moving belt. To increase strength a patterned calender is used consisting of a pair of heated rollers, where one roller has raised pattern “S-shape” according to the invention (Fig. 6). The temperature of the calender rollers (smooth roller / patterned roller) is 165°C/168°C and the pressure is 75 N/mm.

Example 10 - “S” shape

A 14 gsm spinnmelt type nonwoven batt produced online in a continuous process from a mixture of polypropylene (Mosten NB425 from Unipetrol) and color masterbatch (Sanylene

white PPRC 70 from Clariant) in the weight ratio 99.5:0.5, where monocomponent polypropylene filaments with a fibre diameter of 18-30 μm are produced and subsequently collected on a moving belt. To increase strength a patterned calender is used consisting of a pair of heated rollers, where one roller has raised pattern "S-shape" according to the invention (Fig. 6). The temperature of the calender rollers (smooth roller / patterned roller) is 165°C/168°C and the pressure is 75 N/mm.

Example 11 - "S" shape

A 15 gsm spinnmelt type nonwoven batt produced online in a continuous process from polypropylene (Mosten NB425 from Unipetrol), where monocomponent polypropylene filaments with a fibre diameter of 18-30 μm are produced and subsequently collected on a moving belt. To increase strength a patterned calender is used consisting of a pair of heated rollers, where one roller has raised pattern "S-shape" according to the invention (Fig. 6). The temperature of the calender rollers (smooth roller / patterned roller) is 168°C/171°C and the pressure is 75 N/mm.

Example 12 - "S" shape

A 17 gsm spinnmelt type nonwoven batt produced online in a continuous process from polypropylene (Mosten NB425 from Unipetrol), where monocomponent polypropylene filaments with a fibre diameter of 18-30 μm are produced and subsequently collected on a moving belt. To increase strength a patterned calender is used consisting of a pair of heated rollers, where one roller has raised pattern "S-shape" according to the invention (Fig. 6). The temperature of the calender rollers (smooth roller / patterned roller) is 168°C/171°C and the pressure is 75 N/mm.

The strengthened nonwoven web is then subsequently impregnated with a hydrophilic surfactant (Silastol PHP 90 from Schill and Seilacher) using a dip roller (kiss-roll) and dried. The extra weight of the surfactant in dry form is approximately 0.4%.

Example 13 - "S" shape

A 17 gsm spinnmelt type nonwoven batt produced online in a continuous process from polypropylene (Mosten NB425 from Unipetrol), where monocomponent polypropylene filaments with a fibre diameter of 18-30 μm are produced and subsequently collected on a moving belt. To increase strength a patterned calender is used consisting of a pair of heated rollers, where one roller has raised pattern "S-shape" according to the invention (Fig. 6). The temperature of the calender rollers (smooth roller / patterned roller) is 168°C/171°C and the pressure is 75 N/mm.

Example 14 – “wing” shape

A 12 gsm spunmelt type nonwoven batt produced online in a continuous process from polypropylene (Mosten NB425 from Unipetrol), where monocomponent polypropylene filaments with a fibre diameter of 18-30 μm are produced and subsequently collected on a moving belt. To increase strength a patterned calender is used consisting of a pair of heated rollers, where one roller has raised pattern “wing-shape” according to the invention (Fig. 5). The temperature of the calender rollers (smooth roller / patterned roller) is 165°C/168°C and the pressure is 75 N/mm.

Example 15 - “wing” shape

A 14 gsm spunmelt type nonwoven batt produced online in a continuous process from a mixture of polypropylene (Mosten NB425 from Unipetrol) and color masterbatch (CC10031739BG green from PolyOne) in the weight ratio 99.3:0.7, where monocomponent polypropylene filaments with a fibre diameter of 18-30 μm are produced and subsequently collected on a moving belt. To increase strength a patterned calender is used consisting of a pair of heated rollers, where one roller has raised pattern “S-shape” according to the invention (Fig. 5). The temperature of the calender rollers (smooth roller / patterned roller) is 165°C/168°C and the pressure is 75 N/mm.

Example 16 - “wing” shape

A 15 gsm spunmelt type nonwoven batt produced online in a continuous process from polypropylene (Mosten NB425 from Unipetrol), where monocomponent polypropylene filaments with a fibre diameter of 18-30 μm are produced and subsequently collected on a moving belt. To increase strength a patterned calender is used consisting of a pair of heated rollers, where one roller has raised pattern “wing-shape” according to the invention (Fig. 5). The temperature of the calender rollers (smooth roller / patterned roller) is 168°C/171°C and the pressure is 75 N/mm.

Example 17 - “wing” shape

A 17 gsm spunmelt type nonwoven batt produced online in a continuous process from polypropylene (Mosten NB425 from Unipetrol), where monocomponent polypropylene filaments with a fibre diameter of 18-30 μm are produced and subsequently collected on a moving belt. To increase strength a patterned calender is used consisting of a pair of heated rollers, where one roller has raised pattern “wing-shape” according to the invention (Fig. 5). The temperature of the calender rollers (smooth roller / patterned roller) is 168°C/171°C and the pressure is 75 N/mm.

The strengthened nonwoven web is then subsequently impregnated with a hydrophilic surfactant (Silastol PHP 90 from Schill and Seilacher) using a dip roller (kiss-roll) and dried. The extra weight of the surfactant in dry form is approximately 0.4%.

Example 18 - “wing” shape

A 17 gsm spunmelt type nonwoven batt produced online in a continuous process from polypropylene (Mosten NB425 from Unipetrol), where monocomponent polypropylene filaments with a fibre diameter of 18-30 μm are produced and subsequently collected on a moving belt. To increase strength a patterned calender is used consisting of a pair of heated rollers, where one roller has raised pattern “wing-shape” according to the invention (Fig. 5). The temperature of the calender rollers (smooth roller / patterned roller) is 168°C/171°C and the pressure is 75 N/mm.

Example 19 - “wing” shape

A 15 gsm spunmelt type nonwoven batt, produced using a continuous online process from polypropylene (Mosten NB425 from Unipetrol) and polyethylene (Liten LS87 from Unipetrol), where first the bicomponent core/sheath type filaments are produced, where the core representing 50% is from polypropylene and the sheath is from polyethylene. The individual filaments with a fibre diameter of 18-40 μm are collected on a moving belt.

To increase strength a patterned calender is used, that consist of a pair of heated rollers, where one roller has raised pattern “wing-shape” according to the invention (Fig. 5). The temperature of the calender rollers (smooth roller / patterned roller) is 154°C/154°C and the pressure is 75 N/mm.

Example 20 – “S – shape v2”

A 25 gsm spunmelt type nonwoven batt, produced using a continuous online process from polypropylene (Mosten NB425 from Unipetrol) and polyethylene (Liten LS87 from Unipetrol), where first the bicomponent side/side type filaments are produced, where the one side representing 50% is from polyethylene and the second side is from polypropylene. The individual filaments with a fibre diameter of 15 - 25 μm are collected on a moving belt. The batt was produced from two beams REICOFIL 3 technology.

To increase strength a patterned calender is used, that consist of a pair of heated rollers, where one roller has raised pattern “S-shape v2” (Fig. 7). The temperature of the calender rollers (smooth roller / patterned roller) is 152°C/142°C and the pressure is 60 N/mm.

Example 21- “S – shape v2”

A 15 gsm spunmelt type nonwoven batt produced online in a continuous process from polypropylene (Mosten NB425 from Unipetrol), where monocomponent polypropylene filaments with a fibre diameter of 15-25 µm are produced and subsequently collected on a moving belt. The batt was produced from two beams on REICOFIL 3 technology.

To increase strength a patterned calender is used consisting of a pair of heated rollers, where one roller has raised pattern “S-shape v2” according to the invention (Fig. 7). The temperature of the calender rollers (smooth roller / patterned roller) is 150°C/145°C and the pressure is 70 N/mm.

Example 22 – “S – shape v2”

A 25 gsm spunmelt type nonwoven batt, produced using a continuous online process from polypropylene (Mosten NB425 from Unipetrol) and copolymer (Vistamaxx 6202 from Exxon) in the weight ratio 84:16 where first the monocomponent type filaments are produced. The individual filaments a with a fibre diameter of 15 - 25 µm are collected on a moving belt. The batt was produced from two beams on REICOFIL 3 technology.

To increase strength a patterned calender is used, that consist of a pair of heated rollers, where one roller has raised pattern “S-shape v2” (Fig. 7). The temperature of the calender rollers (smooth roller / patterned roller) is 158°C/155°C and the pressure is 70 N/mm.

	Pattern	NW	Modified thickness	Volume mass	Handle O meter – MD	Tensile strength MD/CD ratio	Strike through time (STT)
Mes. unit			mm	kg/m3	mN	-	S
Example 1	Comparative standard bulky	12gsm PP-SSS	0.21	57.1	36.0	3.07	>20
Example 2		14gsm PP-SSS	0.23	60.9	40.0	2.64	>20
Example 3		15gsm PP-SSS	0.24	62.5	46.6	2.50	>20
Example 4		17gsm PP-SSS	0.26	65.4	61.0	2.51	>20
Example 5	Comparative standard	15gsm PP-SSS	0.17	88.2	48.0	2.0	> 20
Example 6		17gsm PP-SSS	0.20	85.0	64.0	2.0	> 20

	Pattern	NW	Modified thickness	Volume mass	Handle O meter - MD	Tensile strength MD/CD ratio	Strike through time (STT)
Mes. unit			mm	kg/m³	mN	-	S
Example 7		15 gsm BICO PLA/PP-S	0.19	79.0	61.0	1.6	>20
Example 8		15 gsm mono PP+copolymer-SS	0.20	75.0	21.2	2.3	>20
Example 9	"S" shape	12gsm PP-SSS	0.23	52.2	33.8	2.40	>20
Example 10		14gsm PP-SSS	0.26	53.8	36.5	2.14	>20
Example 11		15gsm PP-SSS	0.27	55.6	41.9	2.08	>20
Example 12		17 gsm PP-SSS hydrophilic	0.29	58.6	53.9	1.99	3.3
Example 13		17gsm PP-SSS	0.29	58.6	53.9	1.99	>20
Example 14	"wing" shape	12gsm PP-SSS	0.22	54.5	30.4	2.76	>20
Example 15		14gsm PP-SSS	0.25	56.0	34.6	2.26	>20
Example 16		15gsm PP-SSS	0.26	57.7	41.6	2.21	>20
Example 17		17 gsm PP-SSS hydrophilic	0.29	58.6	46.0	2.21	3.2
Example 18		17gsm PP-SSS	0.29	58.6	46.7	2.21	>20
Example 19	"wing" shape	15 gsm BICO PP/PE SSS	0.28	53.6	30.2	2.11	>20
Example 20	"S" shape v2	25 gsm BICO PP/PE side/side-SS	0.39	69.4	53.0	1.90	>20
Example 21	"S" shape v2	15 gsm PP-SS	0.29	53.6	44.1	1.81	>20
Example 22	"S" shape v2	25 gsm PP+copolymer-SS	0.37	74.0	56.3	1.93	>20

Table 1

Test/Measurement methods

Basis Weight

The “basis weight” of a nonwoven web is measured according to the European standard test EN ISO 9073-1:1989 (conforms to WSP 130.1). There are 10 nonwoven web layers used for measurement, sample size 10x10 cm².

Thickness

The “thickness” of a nonwoven web is measured according to the European standard test EN ISO 9073-2:1996 (conforms to WSP 120.6) with following modification: the overall weight of upper arm of the machine including added weight is 130 g.

MD/CD Ratio

The “MD/CD ratio” is the ratio of material’s tensile strength at peak in the MD and CD direction. Both were measured according to the EDANA standard method WSP 110.4-2005, where sample width is 50 mm, jaw distance is 100 mm, speed 100 mm/min and preload 0,1N.

$$\text{MD/CD ratio} = \text{tensile strength at peak in MD[N/5cm]} / \text{tensile strength at peak in CD[N/5cm]}$$

Softness

The “softness” of a nonwoven web may be measured using to the "Handle-O-Meter" test. The test used herein is the INDA IST 90.3-01. The lower the value, the softer is the web.

Volume Mass

The “volume mass” is the ratio of basis weight and thickness and indicates the bulkiness and fluffiness of the product, which are important qualities of the nonwoven web according to the invention. The lower the value, the bulkier is the web.

$$\text{Volume mass [kg/m}^3\text{]} = \text{basis weight [g/m}^2\text{]} / \text{thickness [mm]}.$$

Hydrophilic Properties

The “hydrophilic properties” of a nonwoven web may be measured using the "Strike Through Time" test. The test used herein is the EDANA standard test WSP 70.3-2005. The lower the value, the more hydrophilic is the web.

Opacity

The opacity of a material is the degree to which light is blocked by that material. A higher opacity value indicates a higher degree of light block by the material. Opacity may be

measured using a 0° illumination / 45° detection, circumferential optical geometry, spectrophotometer with a computer interface such as the HunterLab LabScan XE running Universal Software (available from Hunter Associates Laboratory Inc., Reston, VA). Instrument calibration and measurements are made using the standard white and black calibration plates provided by the vendor. All testing is performed in a room maintained at about 23 ± 2 °C and about 50 ± 2 % relative humidity.

Configure the spectrophotometer for the XYZ color scale, D65 illuminant, 10° standard observer, with UV filter set to nominal. Standardize the instrument according to the manufacturer's procedures using the 1.20 inch port size and 1.00 inch area view. After calibration, set the software to the Y opacity procedure.

To obtain the specimen, lay the sample flat on a bench, body facing surface downward, and measure the total longitudinal length of the article. Note a site 33% of the total length from the front waist of the article along the longitudinal axis and a second site, 33% of the total length from the back waist of the article. Carefully remove the backsheet laminate, consisting of both the film and nonwoven web, from the garment-facing side of the article. A cryogenic spray, such as Cyto-Freeze (obtained from Control Company, Houston, TX), may be used to separate the backsheet laminate from the article. Cut a piece 50.8 mm by 50.8 mm centered at each site identified above. Precondition samples at about 23 °C \pm 2 C° and about $50\% \pm 2\%$ relative humidity for 2 hours prior to testing.

Place the specimen over the measurement port. The specimen should completely cover the port with the surface corresponding to the garment-facing surface of the article directed toward the port. Cover the specimen with the white standard plate. Take a reading, then remove the white tile and replace it with black standard tile without moving the specimen. Obtain a second reading, and calculate the opacity as follows:

$$\text{Opacity} = Y \text{ value}_{(\text{black backing})} / Y \text{ value}_{(\text{white backing})} \times 100$$

A total of five identical articles are analyzed and their opacity results recorded. Calculate and report the average opacity and standard deviation for the 10 backsheet laminate measurements to the nearest 0.01%.

Using the same specimens as above, remove the nonwoven web from the film layer for analysis. The cryogenic spray can once again be employed. Precondition samples at about 23 °C

$\pm 2\text{ }^{\circ}\text{C}$ and about $50\% \pm 2\%$ relative humidity for 2 hours prior to testing. In like fashion, analyze the nonwoven web layer following the above procedure. Calculate and report the average opacity and standard deviation for the 10 nonwoven web measurements to the nearest 0.01%.

Bond Shape Measurement Methods

Area, distance and angle measurements are performed on images generated using a flat bed scanner capable of scanning at a resolution of at least 4800 dpi in reflectance mode (a suitable scanner is the Epson Perfection V750 Pro, Epson, USA). Measurements are performed using ImageJ software (Version 1.43u, National Institutes of Health, USA) and calibrated against a ruler certified by NIST.

Samples of the subject nonwoven web that are 80 mm by 80 mm are used. Precondition the samples at about $23\text{ }^{\circ}\text{C} \pm 2\text{ }^{\circ}\text{C}$ and about $50\% \pm 2\%$ relative humidity for 2 hours prior to testing. Identify the machine direction of the nonwoven web and draw a fine line on each sample along the machine direction to enable scanned images to be aligned.

Place the sample to be measured on the flat bed scanner, with the surface bearing the bond impressions or bond shapes facing downward, with the ruler directly adjacent. Placement is such that the dimension corresponding to the machine direction of the nonwoven is parallel to the ruler. A black backing is placed over the specimen and the lid to the scanner is closed. Acquire an image composed of the nonwoven and ruler at 4800 dpi in reflectance mode in 8 bit grayscale and save the file. Open the image file in ImageJ and perform a linear calibration using the imaged ruler.

Unless otherwise stated, dimensional and area measurements are made in triplicate, of three similar bond shapes on each sample for 6 similar samples. The 18 values are averaged and reported.

Not intending to be bound by the specific examples, Figs. 5A through 6B are referenced to illustrate the following dimension measurements. These measurement methods are equally applicable to other bond shapes and repeating bond patterns.

Greatest Measurable Length (L)

The bond shape has a perimeter and a greatest measurable length. Identify a shape length line (*e.g.* line 104) which intersects the two farthest-most points along the perimeter. Draw a shape length line through these points. With the measuring tool, measure the length along the line segment between these points to the nearest 0.001 mm. For example, the greatest

measurable lengths in Figs. 5B and 6B are indicated at L, respectively measured along shape length lines 104.

Greatest Measurable Width (W)

Relative the greatest measurable length, the bond shape has a greatest measurable width measured along a direction perpendicular to the shape length line. Draw two lines, parallel to the shape length line, and tangent to the bond shape perimeter at one or more outermost points that are most distant from the shape length line. These are the shape width lines. With the measuring tool, measure the greatest measurable width between the shape width lines along a line segment perpendicular to the shape length line to the nearest 0.001 mm. For example, the greatest measurable widths in Figs. 5B and 6B are indicated at W, respectively measured between lines 105a and 105b perpendicular to shape length lines 104.

Minimum Passageway Clearance

Any two adjacent bond shapes have minimum passageway clearance, defined as the smallest measurable distance therebetween. Identify the two parallel lines, one tangent to the perimeter of the first shape where it appears closest to the second shape, and one tangent to the perimeter of the second shape where it appears closest to the first shape, that lie closer together than any other such parallel lines that can be identified. The minimum passageway clearance is the distance between the identified parallel lines, measured along a line perpendicular to them.

Camber Height (CH)

If the bond shape has a perimeter with a convex portion, the convex portion has a maximum distance from the shape length line, referred to herein as the camber height. Draw a line that is tangent to the convex portion, and parallel to the shape length line. With the measuring tool, measure the distance between width between this tangent line and the shape length line along a direction perpendicular to the shape length line, to the nearest 0.001 mm. For example, the camber heights of the convex portions in Figs. 5B and 6B are CH, and CH_a and CH_b, respectively.

Concavity Depth (D)

If the bond shape has a perimeter with a concave portion, the concave portion has a maximum distance from the facing shape width line. Draw a line that is tangent to the deepest point along the concave portion of the profile, and parallel to the shape length line. This is the shape concavity line. With the measuring tool, measure the distance between shape concavity

line and the shape length line along a direction perpendicular to the shape length line to the nearest 0.001 mm. For example, the concavity depths of the concave portions in Figs. 5B and 6B are D , and D_a and D_b , respectively.

Shape Tilt Angle (α_T)

The bond shape is rotationally oriented relative the machine direction by shape tilt angle α_T . Draw a line in the cross direction, intersecting the shape length line. Draw a line in the machine direction perpendicular to the cross direction line, intersecting both the cross direction line and the shape length line. Using the angle measuring tool, measure the smaller angle between the machine direction line and the shape length line to the nearest 0.1 degree. For example, the angle between lines 108 and 104 in Figure 5B is the shape tilt angle α_T .

Pattern Tilt Angle (γ_P)

The bond shapes may form a pattern that is tilted from the machine direction by the angle γ_P . Identify a repeating series of bond shapes in a column. Draw a column line that is tangent on one side at the same position on two similar shapes having similar rotational orientations in the column. Draw a line in the machine direction that intersects this column line at an angle, if such a line exists. With the angle measuring tool, measure the smaller angle between the column line and the machine direction line to the nearest 0.1 degree.

Airflow Restriction Ratio

The bond shapes form a pattern that identifies a maximum airflow restriction by the corresponding bonding roller at the nip. Identify a repeating series of bond shapes lying in a row. Draw a line in the cross direction which intersects these bond shapes at the position relative the machine direction where the shapes occupy the greatest proportion of the distance along the cross direction line. It will be appreciated that it may be necessary to take measurements along several cross direction lines to empirically and/or iteratively identify the one along which the bond shapes occupy the greatest proportion of the distance. With the measuring tool, measure the length from the start of the repeating series to the corresponding location at the end of the repeating series (including distances between bonding shapes) to the nearest 0.001 mm. This is the repeat length in the cross direction. With the measuring tool, measure each of the lengths of the line segments on the cross direction line that lie over the bond shapes, to the nearest 0.001 mm. Add the lengths of all of these line segments within the repeat length, and divide the total by the repeat length. Report to the nearest 0.001. This is the airflow restriction ratio. For

example, in Figure 5C, the repeat length w_p is measured along the cross direction line 107a. The line segments lying over the bond shapes are w_1 through w_4 . The airflow restriction ration is the sum of lengths w_1 through w_4 divided by the repeat length w_p .

Cross-nip Airflow Angle (β_A)

The bond pattern may provide an airflow path that has a machine direction vector component. Draw a line in the cross direction. Identify a line that can be drawn that extends past at least eight rows of bond shapes without intersecting a bond shape, if such a line exists. This is the cross-nip airflow line. Extend this line to intersect the cross direction line. Using the angle measurement tool, measure the smaller angle between the cross direction line and the airflow line and report to the nearest 0.1 degree. For example, lines 109 in Figure 5A and 109 in figure 6A are cross-nip airflow lines which intersect the cross direction lines 107 to form the cross-nip airflow angles β_A .

Bond Area Percentage

Identify a single repeat pattern of bond shapes and areas between them and enlarge the image such that the repeat pattern fills the field of view. In ImageJ, draw a rectangle that circumscribes the repeat pattern. Calculate area of the rectangle and record to the nearest 0.001 mm². Next, with the area tool, trace the individual bond shapes or portions thereof that are entirely within the repeat pattern/rectangle and calculate and add the areas of all bond shapes or portions thereof that are within the repeat pattern/rectangle. Record to the nearest 0.001 mm². Calculate as follows:

$$\text{Bond Area \%} = (\text{Sum of areas of bond shapes within repeat pattern}) / (\text{total area of repeat pattern}) \times 100\%$$

Repeat for a total of three non-adjacent regions randomly selected across the sample. Record as Percent Bond Area to the nearest 0.01%. Calculate the average and standard deviation of all 18 of the bond area percentage measurements and report to the nearest 0.01 %.

Average Individual Bond Area

Enlarge the image of a region of the sample such that edges of a bond shape can be identified. With the area tool, manually trace the perimeter of a bond. Calculate and record the area to the nearest 0.001 mm². Repeat for a total of five non-adjacent bonds randomly selected across the total sample. Measurements are made on each sample. A total of six samples are measured. Calculate the average and standard deviation of all 30 bond area measurements and report to the nearest 0.001 mm².

The dimensions and values disclosed herein are not to be understood as being strictly limited to the exact numerical values recited. Instead, unless otherwise specified, each such dimension is intended to mean both the recited value and a functionally equivalent range surrounding that value. For example, a dimension disclosed as “40 mm” is intended to mean “about 40 mm.”

Every document cited herein, including any cross referenced or related patent or application, is hereby incorporated herein by reference in its entirety unless expressly excluded or otherwise limited. The citation of any document is not an admission that it is prior art with respect to any invention disclosed or claimed herein or that it alone, or in any combination with any other reference or references, teaches, suggests or discloses any such invention. Further, to the extent that any meaning or definition of a term in this document conflicts with any meaning or definition of the same term in a document incorporated by reference, the meaning or definition assigned to that term in this document shall govern.

While particular embodiments of the present invention have been illustrated and described, it would be obvious to those skilled in the art that various other changes and modifications can be made without departing from the spirit and scope of the invention. It is therefore intended to cover in the appended claims all such changes and modifications that are within the scope of this invention.

CLAIMS

What is claimed is:

1. An article of manufacture having as a component a section of a nonwoven web having a macroscopic surface approximating a plane, a machine direction and a cross direction perpendicular to the machine direction, the nonwoven web formed predominately of polymeric fibers and comprising a series of one or more consolidating bonds impressed on the surface, the one or more consolidating bonds having at least one bond shape; wherein the series is repeated to form a pattern of consolidating bonds; wherein the series is repeated in at least four rows extending predominately in the cross direction, and the series is repeated in at least four columns extending predominately in the machine direction; and wherein the bond shape has a perimeter with a greatest measurable length and a greatest measurable width, and the perimeter has a convex portion;

the article characterized in that the bond shape perimeter:

has an aspect ratio of the greatest measurable length to the greatest measurable width of at least 2.5; and

is oriented such that a line intersecting the perimeter along which the greatest measurable length exists intersects an axis lying on the surface along the machine direction to form a smaller angle of between 1 degree and 40 degrees.

2. The article of Claim 1 wherein the pattern is arranged such that an airflow line may be identified on the surface, that passes at least 8 rows of consolidating bonds, without intersecting a bond shape, and intersects an axis lying on the surface along the cross direction, to form a smaller angle of greater than 45 degrees.
3. The article of either of the preceding claims wherein the convex portion has varying radii.
4. The article of any of the preceding claims wherein the nonwoven web has a basis weight of 25 gsm or less.
5. The article of any of the preceding claims wherein the perimeter also has a concave portion disposed substantially opposite the convex portion.

6. The article of any of the preceding claims wherein bonds having the repeated bond shape are arranged in identical rotational orientation along a line lying on the surface along the machine direction.
7. The article of any of Claims 1 through 5 wherein bonds having the repeated bond shape are arranged in identical rotational orientation in a column along a line lying on the surface that intersects an axis lying on the surface along the machine direction to form a smaller angle between 0 degrees and 4 degrees, more preferably between 0 degrees and 3 degrees, and even more preferably between 0 degrees and 2.5 degrees.
8. The article of any of the preceding claims wherein the greatest measurable length lies along a line lying on the surface that intersects an axis lying on the surface along the machine direction to form a smaller angle between 5 degrees and 15 degrees.
9. The article of any of the preceding claims wherein the concave portion has a concavity depth ratio between 0.00 and 0.30.
10. The article of any of the preceding claims wherein the convex portion has a camber height, and the ratio of the camber height to the greatest measurable length is 0.30 or less.
11. The article of any of the preceding claims wherein the perimeter has two convex portions.
12. The article of Claim 11 wherein the perimeter has two concave portions respectively disposed substantially opposite the convex portions.
13. The article of any of the preceding claims wherein the article is an absorbent article.
14. An article of manufacture having as a component a section of a nonwoven web having a macroscopic surface approximating a plane, a machine direction and a cross direction perpendicular to the machine direction, the nonwoven web formed predominately of polymeric fibers and comprising a series of one or more consolidating bonds impressed on the surface, the one or more consolidating bonds having at least one bond shape; wherein the series is repeated to form a pattern of consolidating bonds; wherein the series is repeated in at least four rows extending predominately in the cross direction, and the series is repeated in at least four columns extending predominately in the machine direction; and wherein the bond shape has a perimeter with a greatest measurable length and a greatest measurable width, and the perimeter has a convex portion;

the article characterized in that the bond shape perimeter:

has an aspect ratio of the greatest measurable length to the greatest measurable width of at least 2.5; and

the bond shape is asymmetric about any line that traverses the perimeter.

15. An article of manufacture having as a component a section of a nonwoven web having a macroscopic surface approximating a plane, a machine direction and a cross direction perpendicular to the machine direction, the nonwoven web formed predominately of polymeric fibers and comprising a series of one or more consolidating bonds impressed on the surface, the one or more consolidating bonds having at least one bond shape; wherein the series is repeated to form a pattern of consolidating bonds; wherein the series is repeated in at least four rows extending predominately in the cross direction, and the series is repeated in at least four columns extending predominately in the machine direction; and wherein the bond shape has a perimeter with a greatest measurable length and a greatest measurable width, and the perimeter has a convex portion;

the article characterized in that the bond shape perimeter:

has an aspect ratio of the greatest measurable length to the greatest measurable width of at least 2.5;

is oriented such that a line intersecting the perimeter along which the greatest measurable length exists intersects an axis lying on the surface along the machine direction to form a smaller angle of between 1 degree and 40 degrees;

and the pattern has a nip airflow restriction ratio of 0.40 or less.

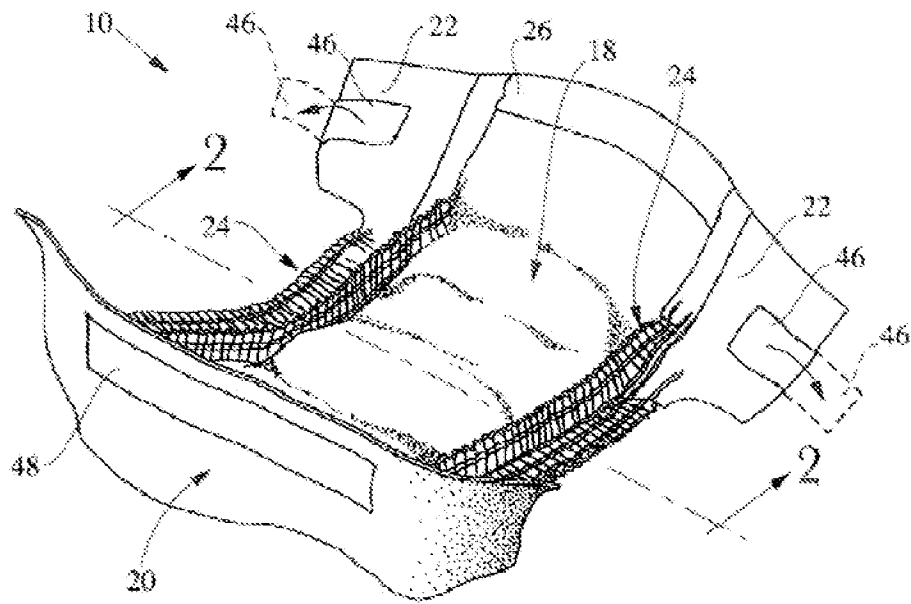

Fig. 1A

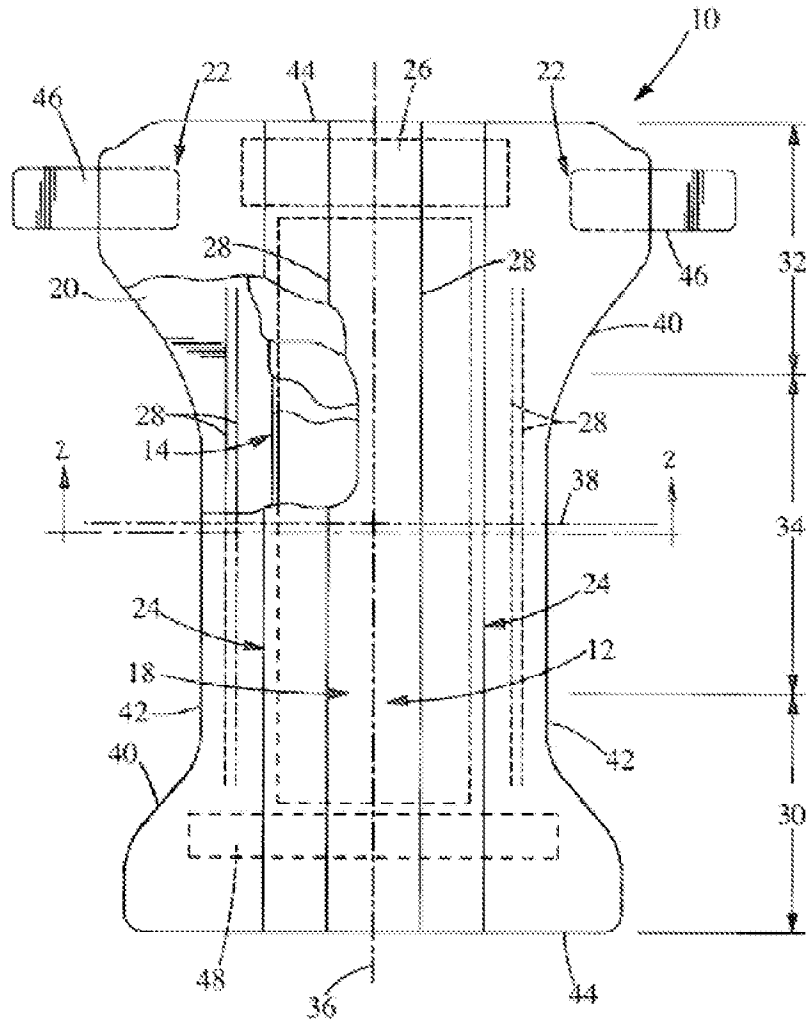

Fig. 1B

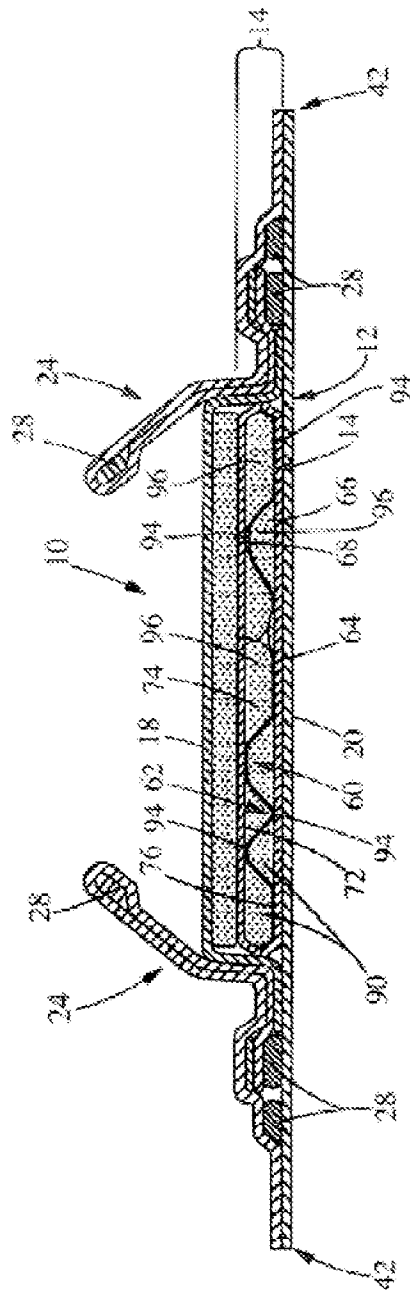

Fig. 2A

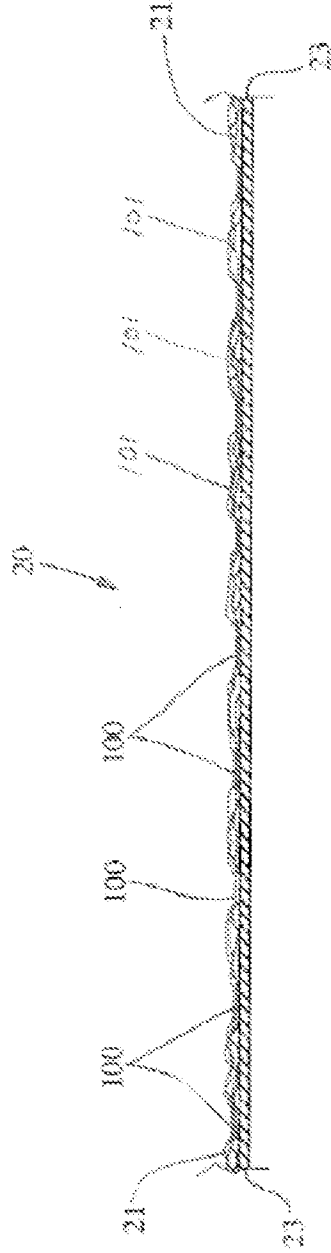

Fig. 2B

5/13

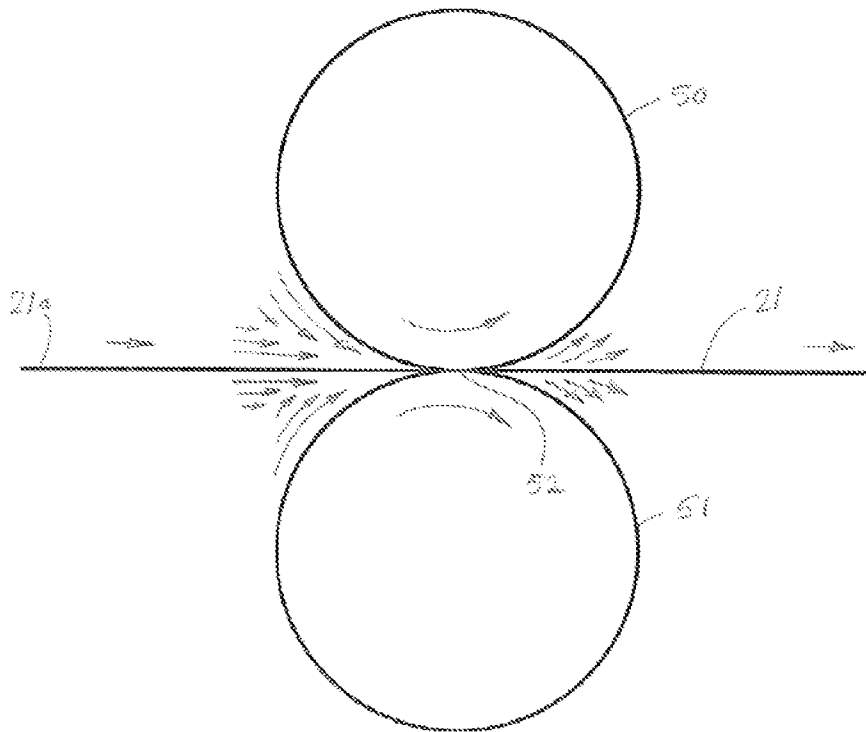

Fig. 3

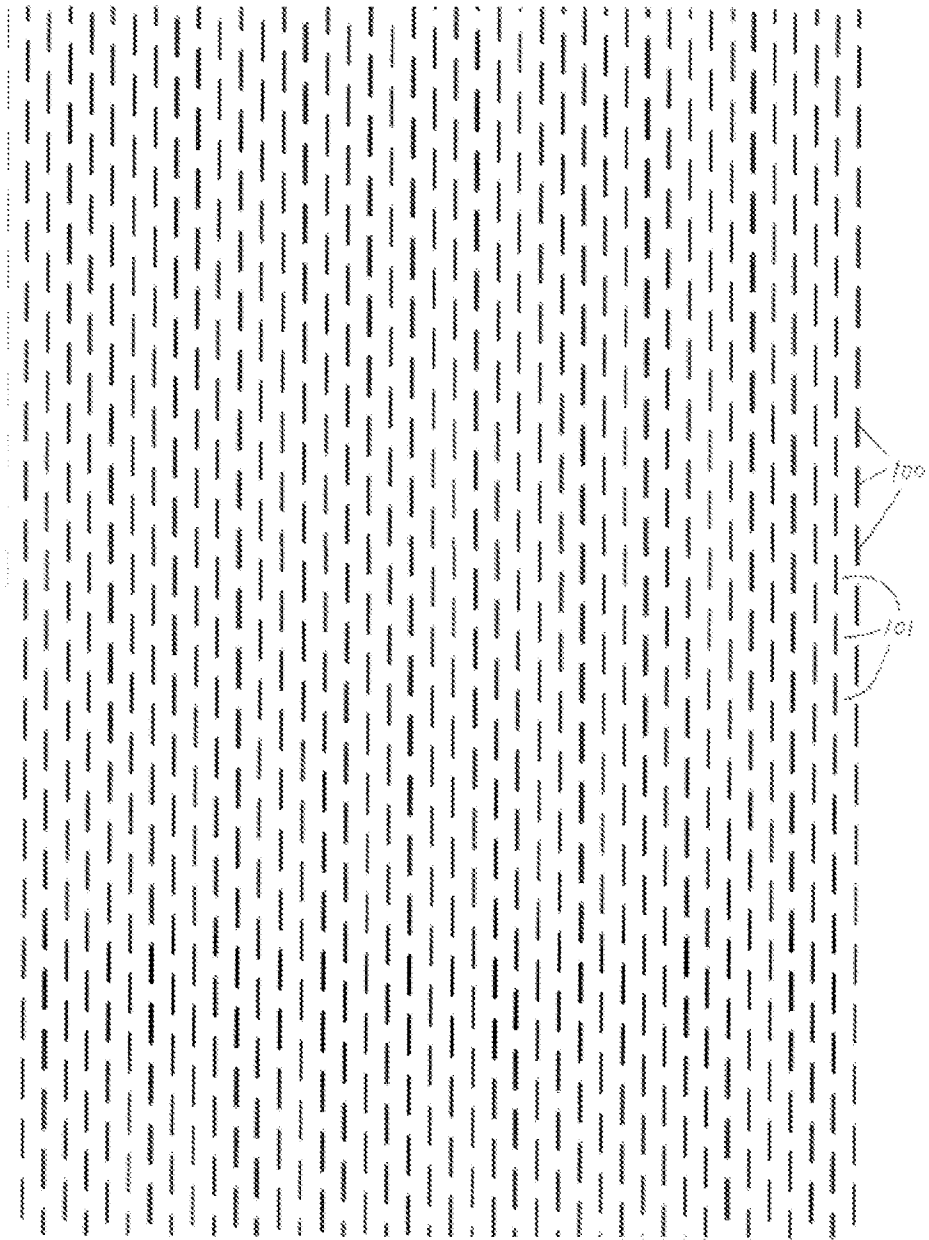

Fig. 4A

7/13

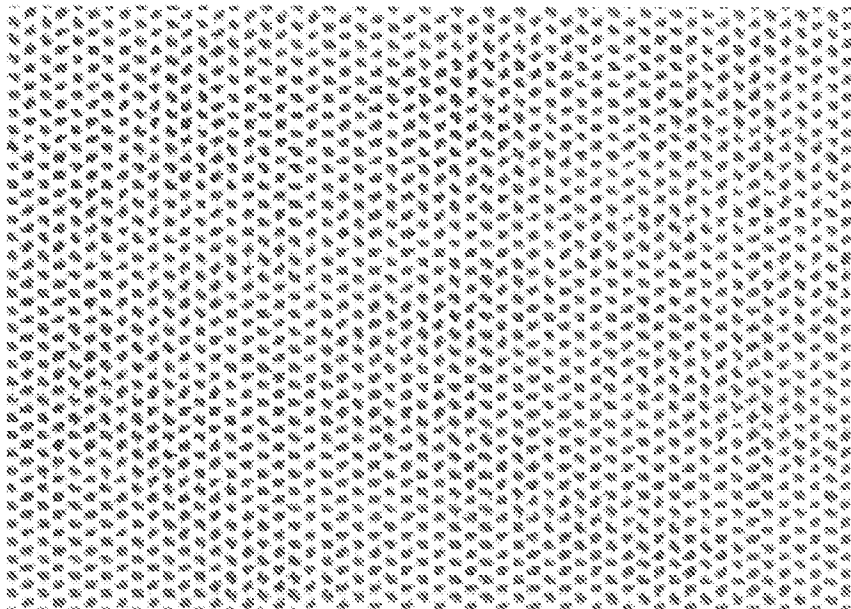

Fig. 4B

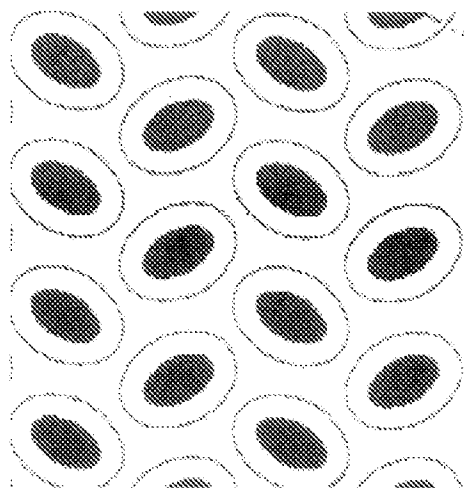

Fig. 4C

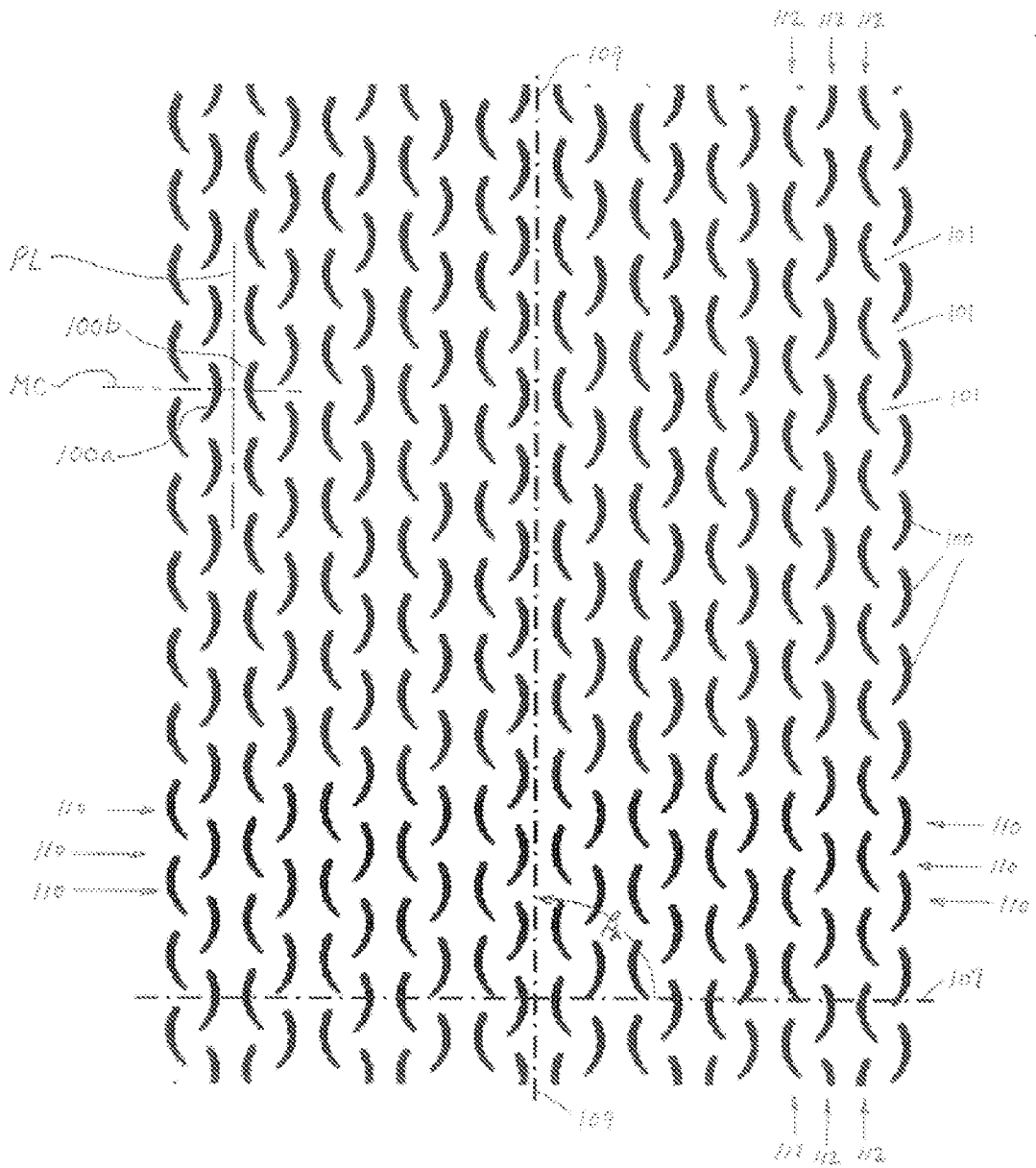

Fig. 5A

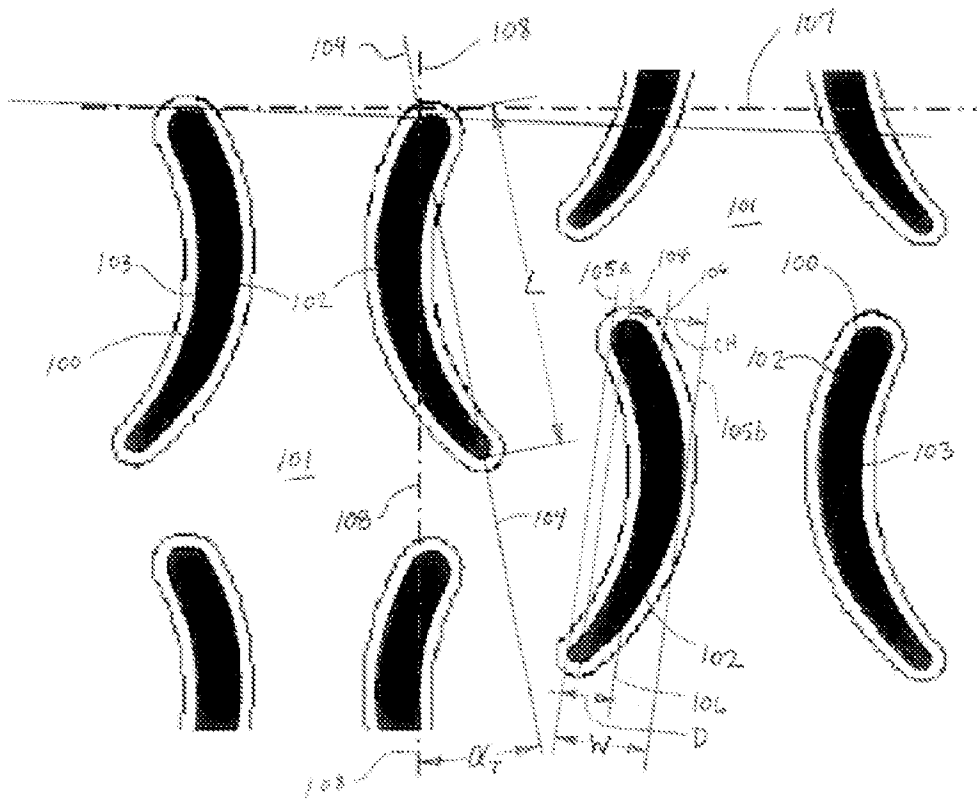

Fig. 5B

10/13

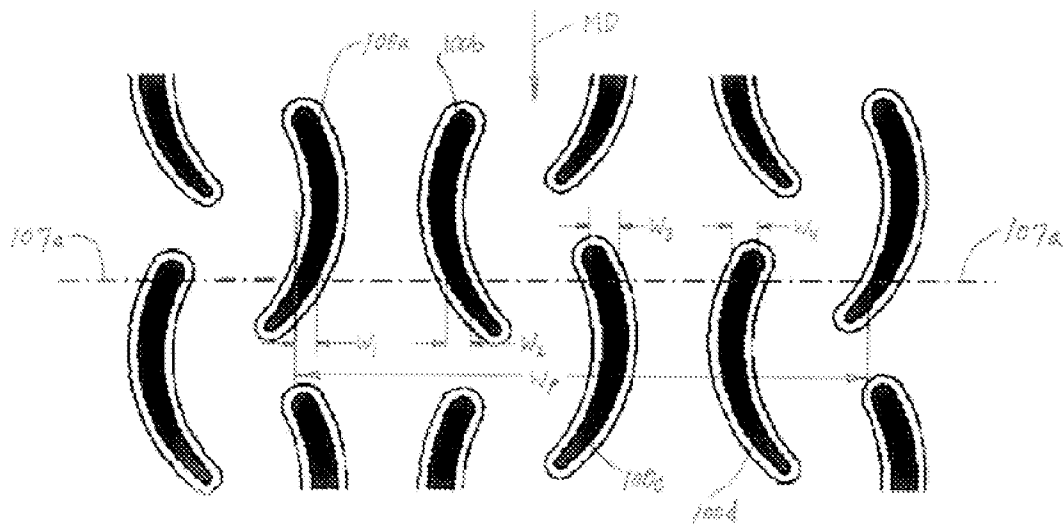

Fig. 5C

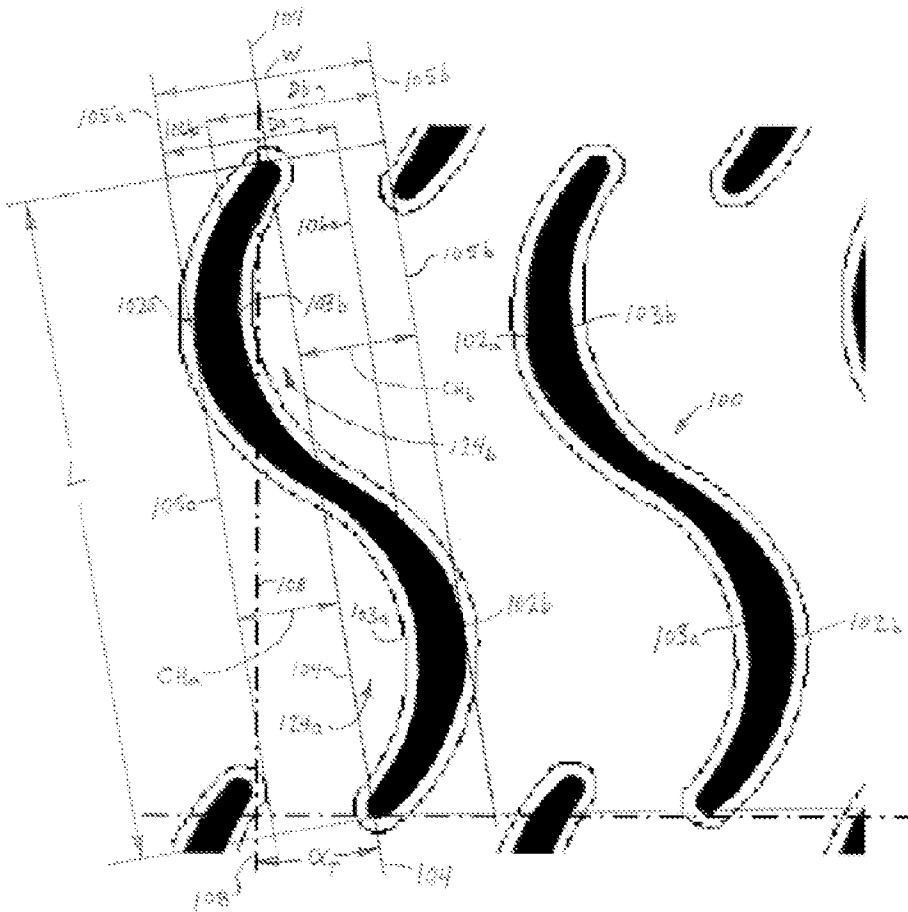

Fig. 6B

INTERNATIONAL SEARCH REPORT

International application No
PCT/US2012/030266

A. CLASSIFICATION OF SUBJECT MATTER INV. A61F13/15 D04H1/485 ADD.		
According to International Patent Classification (IPC) or to both national classification and IPC		
B. FIELDS SEARCHED		
Minimum documentation searched (classification system followed by classification symbols) A61F D04H		
Documentation searched other than minimum documentation to the extent that such documents are included in the fields searched		
Electronic data base consulted during the international search (name of data base and, where practicable, search terms used) EPO-Internal		
C. DOCUMENTS CONSIDERED TO BE RELEVANT		
Category*	Citation of document, with indication, where appropriate, of the relevant passages	Relevant to claim No.
X	WO 2009/021473 A1 (PEGAS NONWOVENS S R O [CZ]; KLASKA FRANTISEK [CZ]) 19 February 2009 (2009-02-19) page 3, lines 14-21 page 4, line 19 - page 5, line 20; figures 1,2	1,14,15
A	----- US 2008/315464 A1 (SMITHIES ALAN [US] ET AL) 25 December 2008 (2008-12-25) paragraphs [0020] - [0023]	1-15
A	----- US 5 057 357 A (WINEBARGER CRAIG M [US]) 15 October 1991 (1991-10-15) column 3, line 54 - column 4, line 59 ----- -/--	1-15
<input checked="" type="checkbox"/> Further documents are listed in the continuation of Box C. <input checked="" type="checkbox"/> See patent family annex.		
* Special categories of cited documents :		
"A" document defining the general state of the art which is not considered to be of particular relevance	"T" later document published after the international filing date or priority date and not in conflict with the application but cited to understand the principle or theory underlying the invention	
"E" earlier application or patent but published on or after the international filing date	"X" document of particular relevance; the claimed invention cannot be considered novel or cannot be considered to involve an inventive step when the document is taken alone	
"L" document which may throw doubts on priority claim(s) or which is cited to establish the publication date of another citation or other special reason (as specified)	"Y" document of particular relevance; the claimed invention cannot be considered to involve an inventive step when the document is combined with one or more other such documents, such combination being obvious to a person skilled in the art	
"O" document referring to an oral disclosure, use, exhibition or other means	"&" document member of the same patent family	
"P" document published prior to the international filing date but later than the priority date claimed		
Date of the actual completion of the international search 21 June 2012	Date of mailing of the international search report 04/07/2012	
Name and mailing address of the ISA/ European Patent Office, P.B. 5818 Patentlaan 2 NL - 2280 HV Rijswijk Tel. (+31-70) 340-2040, Fax: (+31-70) 340-3016	Authorized officer Lanniel, Geneviève	

INTERNATIONAL SEARCH REPORT

International application No

PCT/US2012/030266

C(Continuation). DOCUMENTS CONSIDERED TO BE RELEVANT

Category*	Citation of document, with indication, where appropriate, of the relevant passages	Relevant to claim No.
A	WO 00/78883 A1 (3M INNOVATIVE PROPERTIES CO [US]; SWANSON DAVID P [US]; MAKI ROBERT J) 28 December 2000 (2000-12-28) page 5, line 25 - page 7, line 2 page 15, lines 9-31; figure 1 -----	1-15

INTERNATIONAL SEARCH REPORT

Information on patent family members

International application No

PCT/US2012/030266

Patent document cited in search report	Publication date	Patent family member(s)	Publication date
WO 2009021473	A1	19-02-2009	EP 2188428 A1 26-05-2010
			RU 2010107735 A 10-09-2011
			US 2010305543 A1 02-12-2010
			WO 2009021473 A1 19-02-2009

US 2008315464	A1	25-12-2008	NONE

US 5057357	A	15-10-1991	NONE

WO 0078883	A1	28-12-2000	AU 773212 B2 20-05-2004
			AU 4697899 A 09-01-2001
			CA 2375146 A1 28-12-2000
			DE 69932952 T2 26-04-2007
			EP 1194495 A1 10-04-2002
			ES 2272073 T3 16-04-2007
			JP 2003503538 A 28-01-2003
			MX PA01012972 A 02-09-2002
			TW 449551 B 11-08-2001
			WO 0078883 A1 28-12-2000
