

No. 714,264.

Patented Nov. 25, 1902.

J. K. TURAJSKI.  
SIPHON BOTTLE FILLER.

(Application filed Jan. 6, 1902.)

(No Model.)

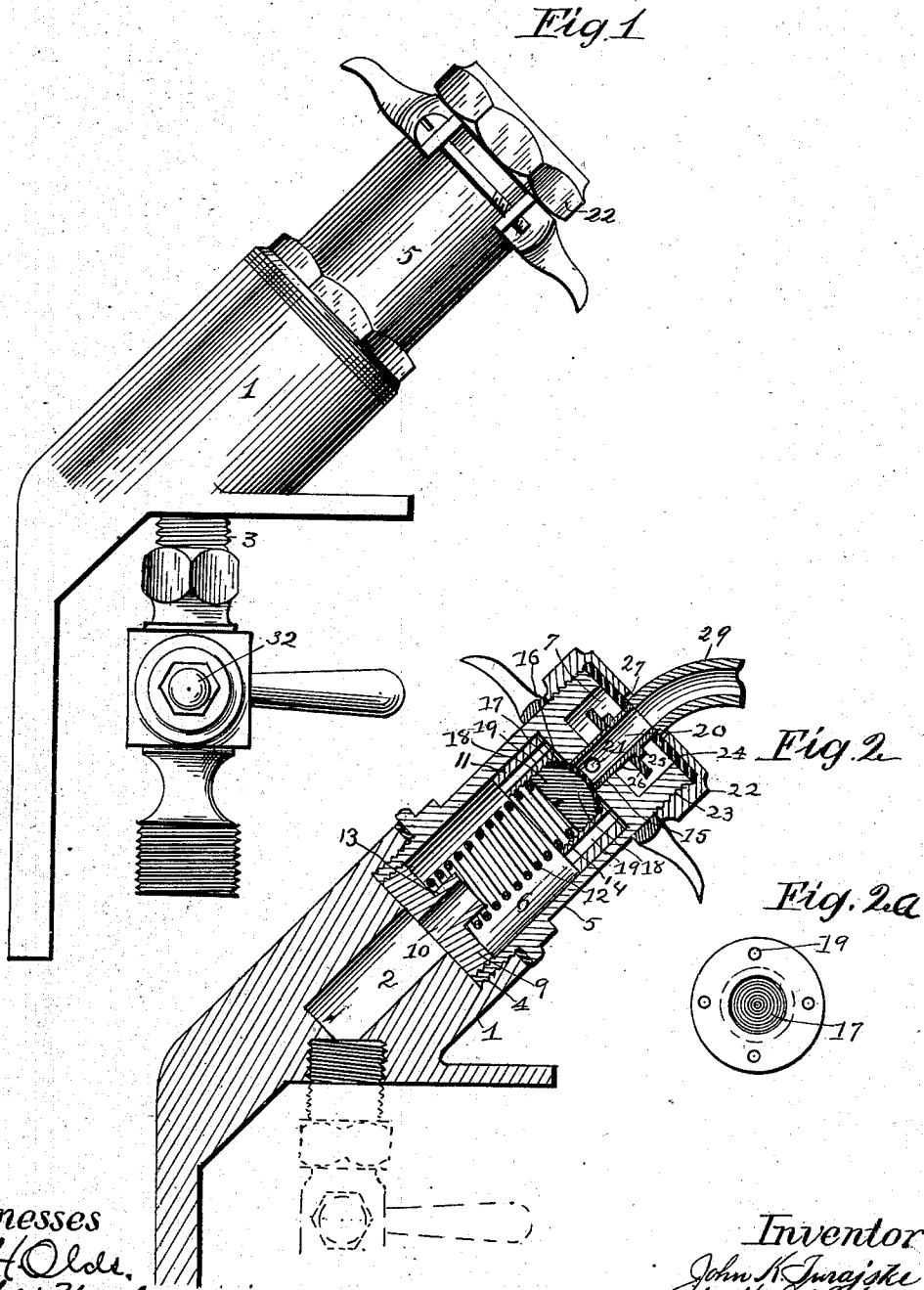

Witnesses  
C. H. Olds,  
S. M. Threlker

Inventor  
John K. Turajski  
By Wm. M. Sherman  
Attorney

# UNITED STATES PATENT OFFICE.

JOHN K. TURAJSKI, OF CLEVELAND, OHIO.

## SIPHON-BOTTLE FILLER.

SPECIFICATION forming part of Letters Patent No. 714,264, dated November 25, 1902.

Application filed January 6, 1902. Serial No. 88,550. (No model.)

*To all whom it may concern:*

Be it known that I, JOHN K. TURAJSKI, a citizen of the United States, and a resident of Cleveland, county of Cuyahoga, State of Ohio, have invented certain new and useful Improvements in Siphon-Bottle Fillers, of which I hereby declare the following to be a full, clear, and exact description, such as will enable others skilled in the art to which it appertains to make and use the same.

My invention relates to improvements in devices for charging seltzer-bottles with fluid under pressure; and the objects of the invention are to provide simple and efficient means for charging the bottles without leakage or waste and also to provide a valve mechanism for this purpose which cannot get out of order and in which none of the parts can become accidentally displaced or lost and by means of which the supply from the seltzer-tank need never be shut off.

My invention consists in the stock portion to which the nozzle leading from the reservoir is secured and in the detachable outlet device from which the bottle is automatically fed, with the details of combination and arrangement of the various parts, as herein-after described, shown in the accompanying drawings, and pointed out in the claim.

In the accompanying drawings, Figure 1 is a side elevation of the complete device. Fig. 2 is a central vertical section of the same. Fig. 2<sup>a</sup> is a plan view of the valve.

In the drawings, 1 is the stock, which is bored at 2 to form a passage for the fluid, which enters through the cock or nozzle 3 of the tube leading from the charging-reservoir. This stock is permanently attached to the wall of a room, ice-box, or a bar, and to it is attached by a screw-threaded extremity 4 the barrel 5 of the bottle-feeding device. This barrel is bored at either end at 6 and 7 to form valve-chambers, separated by the partition 8. The lower chamber 6 is closed at the lower end by means of the disk 9, in which is the central opening 10 to admit the fluid to the chamber. In this chamber is the piston-valve 11, of equal area to the cylindrical chamber in which it plays, which is normally maintained in a state of close engagement against the partition 8 by means of the pressure of the carbonated fluid from the reser-

voir. Suitable engaging devices for the spring upon the disk 9 and under surface of the valve 11, as the projection 13 on the one and recess 14 on the other, are shown.

A central opening 15 is made in the partition 8, and an annular rib 16 about the edge of this opening receives the thrust of the piston-valve 11, which normally shuts off the passage of the fluid from the opening 15. A rubber cushion 17, secured by means of the screw-threaded plug 18 to the upper surface of the piston, serves to form a complete stop for the fluid until the piston is forced downward from above, when the fluid is free to flow through openings 19 in the piston, and thus pass by it. These openings are less in total area than the area of the piston, so as not to greatly affect the pressure of the fluid thereon.

The outer chamber is provided with an air-tight contrivance to push downward the piston-valve and conduct fluid to the bottle. This will be seen to consist of a tubular conduit 20, seated in the opening 15 and provided with transverse passages 21 in its walls, so that when pushed downward the fluid will enter therethrough.

A cap 22 is screwed at 23 over the open extremity of the outer chamber, and a rubber washer 24, closely engaging the outer extremity of the conduit-tube and compressed between the cap and wall of the chamber, serves to prevent the escape of any fluid into the chamber.

A shoulder 25 on the tube and rubber washer 26 on the tube underneath the shoulder make an air-tight joint upon the partition when the tube is pressed downward.

In use the curved extremity 29 of the bottle after the valve therein has been opened is inserted into the opening 27 in the cap 22 and engages the conduit-tube and rubber washer 24, thus making the opening to the bottle tight. The nozzle of the bottle is pushed downward, thus forcing down the tube and piston-valve, when the fluid often under one hundred and eighty pounds pressure to the inch will rush through the openings in the piston, then through the openings in the lower end of the conduit-tube, and thence through the tube to the bottle. As soon as the bottle is removed the fluid-pressure under the pis-

ton-valve will close it at once against the annular ridge on the lower face of the partition and of course instantly shut off the fluid from the conduit-tube. Thus the device will be seen to be always ready for instant use and to be arranged in the most convenient manner for the operator.

One of the leading advantages of this device will be seen to consist in the fact that no valve or cock is needed upon the pipe leading from the seltzer-reservoir no matter how high the pressure, since the piston - valve works automatically to shut off the flow of fluid except when the bottle is actually being filled. One, however, is shown at 32 for use to close the pipe in case of any accident to the piston-valve or when repairs are being made in the feeding device.

I claim—

In combination, in a siphon-filler, a barrel provided with upper and lower cylindrical

chambers, a perforated partition separating the chambers, a piston of an equal area to the lower chamber placed therein and adapted to normally close the said perforation, when influenced by fluid-pressure in the chamber, a washer on the upper face of the piston, passages of less total area than the lower chamber passing through the piston, a conduit-tube entering the perforation in the said partition, and adapted to remove the piston from engagement with the partition and provided with transverse openings in its lower end substantially as described.

In testimony whereof I have signed my name to this specification in the presence of two subscribing witnesses.

JOHN K. TURAJSKI.

Witnesses:

GEO. O. WILLET,  
WM. M. MONROE.