



(12) **EUROPEAN PATENT APPLICATION**

(43) Date of publication:
12.07.2006 Bulletin 2006/28

(51) Int Cl.:
B63C 9/20 (2006.01)

(21) Application number: **06100193.9**

(22) Date of filing: **10.01.2006**

(84) Designated Contracting States:
**AT BE BG CH CY CZ DE DK EE ES FI FR GB GR
HU IE IS IT LI LT LU LV MC NL PL PT RO SE SI
SK TR**
Designated Extension States:
AL BA HR MK YU

(71) Applicant: **SIC DIVISIONE ELETTRONICA S.R.L.**
73100 Surbo LE (IT)

(72) Inventor: **Aguglia, Jorge Miguel**
73100 Lecce (IT)

(30) Priority: **11.01.2005 IT TO20050004**

(74) Representative: **Robba, Pierpaolo et al**
INTERPATENT S.R.L.,
Via Caboto No.35
10129 Torino (IT)

(54) **Emergency indicator**

(57) Emergency indicator (5) for signalling emergency situations comprising an electronic circuit (70) arranged to signal emergency situations through intermit-

tent light signals and a light-weight shell (20) shaped so as to contain the electronic circuit (70) and to render the indicator (5) impermeable to water and apt to be self floating.

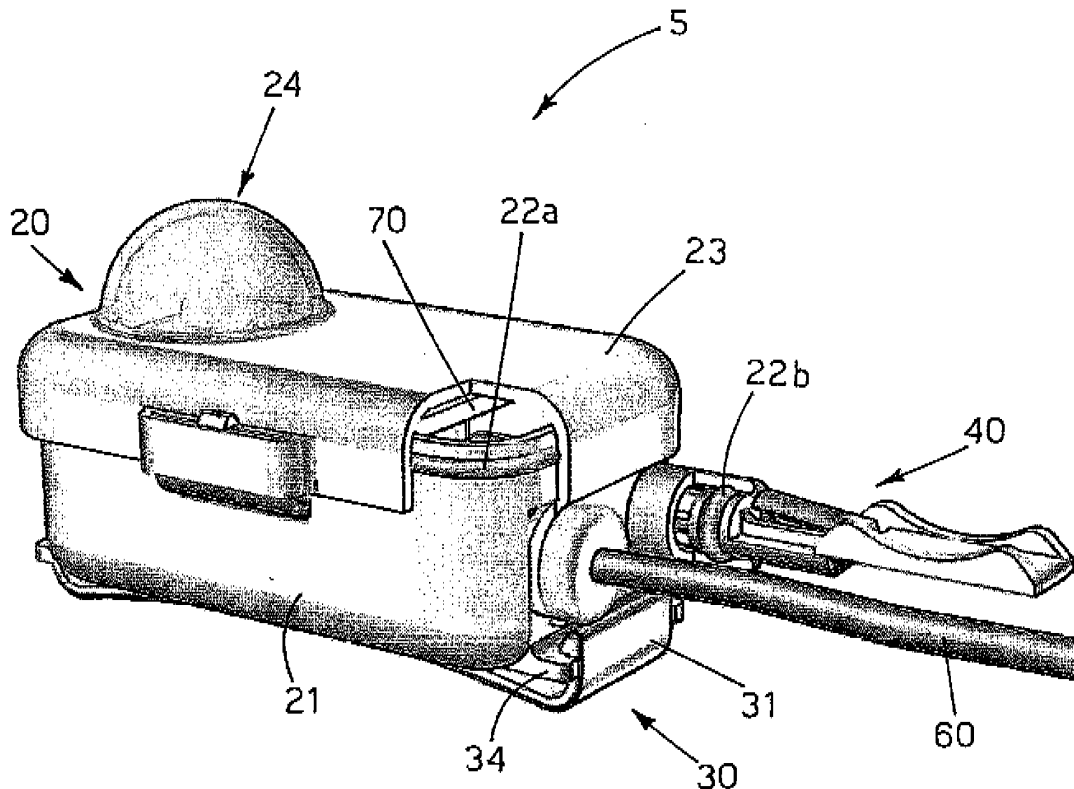

Fig. 1

Description

Technical Field

[0001] The present invention relates, in general, to an emergency indicator to be mounted, for instance, on life belts and/or jackets, for signalling emergency situations, as for instance presence of shipwrecked persons as a consequence of a shipwreck.

In particular, the present invention relates to an emergency indicator that complies with the "LSA Code" standards of the "IMO MSC 48 (66) Resolution" and "IMO 81 (70) Resolution", as well as that is in conformity with "EU Directive on Marine Equipment or MED".

Background Art

[0002] Emergency indicators (indicators) are known in the art, in particular intermittent light indicators for persons shipwrecked at sea.

Such indicators are mounted on life belts or jackets and have the main function to allow locating persons fallen into the water or missing persons at sea.

In particular, such indicators comprise an electronic circuit apt to guarantee one or more of the following characteristics:

- at least 24 hours of operation autonomy;
- luminous emission higher than 0,75 cd after 8 operation hours;
- effective luminous intensity higher than 0,75 cd;
- light emission in a whole hemisphere;
- automatic power on when in contact with marine water;
- flashing frequency higher than 50 flash per minute;
- manual power on and deactivation or power off;
- operating temperature between - 20°C and + 65°C.

[0003] A first problem of the known indicators is that in general the electronic circuit is sealed or rendered impermeable to humidity or water infiltration by the use of impregnation resins, for instance epoxy resins, that render such indicators, as a whole, particularly heavy and not self floating.

Such a fact renders known indicators ineffective in emergency situations if they should come off the life jacket whereto they are hooked.

[0004] A second problem lies in the fact that such indicators typically comprise an incandescent lamp that, as is known, emits a yellow light which, being not perfectly white, is less visible than a perfectly white light.

[0005] Applicant has found that such problems render the use of known indicators not safe and not very effective, indeed in emergency situations in which such safety and effectiveness would be required, for instance in the form of flotation of such indicators even in case they should come off the jacket and/or in the form of a perfectly white light therefore easily visible from far away.

Disclosure of the Invention

[0006] Object of the present invention is an emergency indicator for life belts or life jackets apt to overcome the problems of the background art as highlighted.

Such an object is achieved by means of an emergency indicator having the features set forth in the claims that follow; such claims are an integral part of the teaching of the present invention.

[0007] According to one of the features of the present invention, the emergency indicator comprises a shell arranged to protect the electronic circuit from water or humidity infiltration and it is apt to guarantee, for instance, the flotation of the indicator even if, in situations of emergency, this should come off the life jacket whereto it is hooked.

[0008] According to another feature of the present invention, the indicator comprises an aid light including, in particular, a white light LED diode.

[0009] According to a further feature of the present invention, the indicator comprises an electronic circuit apt to optimise the electric power consumption during operation.

[0010] According to still another feature of the present invention, the indicator comprises an extremely user-friendly switch for manually activating and deactivating the operation of the indicator itself.

Brief Description of Drawings

[0011] These and further features of the present invention will appear more clearly from the following detailed description of preferred embodiments, provided by way of non-limiting examples with reference to the attached drawings, wherein:

Fig. 1 shows an emergency indicator according to the invention;

Fig. 2 shows a logic diagram of an electronic circuit usable in the Fig. 1 emergency indicator; and

Fig. 3 schematically shows a manual switch usable in the Fig. 1 emergency indicator.

Best mode for Carrying Out the Invention

[0012] With reference to Fig. 1 an emergency indicator (indicator) 5 according to present invention comprises a body (shell) 20 suitable to house an electronic circuit 70 adapted to generate aid signals, as it will be disclosed later on in detail.

[0013] In the preferred embodiment, a sensor device (Fig.1, Fig.2) 61, of known type, is connected to the body 20 and to the electronic circuit 70 through a cable 60, said sensor device 61 being arranged to allow the automatic activation of the electronic circuit 70 if the same sensor 61 is immersed, for instance, into marine water or if it gets wet.

Obviously, in other embodiments the sensor 61 and the

corresponding cable 60 may also be missing.

An activation switch (switch) 40 arranged to allow the manual activation of the electronic circuit 70 is connected, in the preferred embodiment, to the body and to the electronic circuit 70.

Such a switch 40, in other embodiments, may completely replace the sensor 60 or, it may even be replaced by the same.

[0014] The body 20 comprises, associated thereto, a coupler device 30, of known type, apt to allow, for instance, engagement of the indicator 5 to a life jacket, known per se. The coupler device comprises, for instance, a clip 31, separated from the body 20, and with its ends shaped so as to be able to be securely hooked to the life jacket through corresponding indentations 34 obtained in the body 20 of the indicator 5.

[0015] The shell 20 comprises, in the preferred embodiment, a first shell element (lower body) 21 and a second shell element (upper body) 23; the lower body 21 is apt to be embedded, in known way, in the upper body 23.

The upper body 23 preferably comprises a transparent dome 24, obtained for instance by press-moulding of the same material as the body 20.

The dome 24 is apt to render visible, in known way, the light emitted by the electronic circuit 70, as it will be disclosed later on in detail.

The body 20, in its entirety, and the clip 31 are made, in the preferred embodiment, of light-weight plastic material, for instance of polycarbonate, so as to allow embedding between the upper body 23 and the lower body 21, in a very reliable and flexible way.

In the preferred embodiment, between the lower body 21 and the upper body 23 and between the switch 40 and the body 20 corresponding washers or sealing rings, 22a and 22b, are interposed, as for instance "O-RING" type washers having circular cross-section and apt to render the indicator 5 highly watertight.

Obviously, also washers or sealing rings having other shapes may be used, provided that they allow to attain the object to impermeabilise the indicator to water and humidity.

The use of light-weight materials for the body 20 and the insertion of the washers 22a and 22b is apt to allow the indicator 5 to be self floating and to operate as emergency indicator also in case, for instance, such an indicator 5 should come off the life jacket.

Obviously, in other embodiments, the shell 20 may also be made of more than two shell elements, provided that the shell elements must be closely embedded and protected with sealing rings or elements so as to prevent water or humidity infiltration into the shell.

[0016] The electronic circuit 70 (Fig.2) comprises, in the preferred embodiment, a battery 71, of known type, for instance a lithium dry battery of 3V CR123 type, a light emitting device (LED) 76, of known type, arranged to emit light, a pilot circuit 74 connected to the LED 76 for activating operation thereof according to predeter-

mined time intervals and a power control circuit 73, interposed between the battery 71 and the pilot circuit 74. The electronic circuit 70, in the preferred embodiment, is connected, externally to the body 20, to the switch 40 and, preferably, in series thereto, to the sensor 61 (through the cable 60), both being apt to activate respectively manually and automatically the operation of the electronic circuit 70 itself.

[0017] The light emitting device (LED) 76, in the preferred embodiment, is comprised of a white LED diode having high efficiency to emit white light (true white) with high visual impact (luminous intensity greater than 0,75 cd) and such to guarantee to the indicator 5 of easy visibility in emergency situations.

Obviously, in other embodiments the diode can be replaced by light emitting devices of other types, provided that such devices are adapted to the object of being easily sighted in emergency situations.

[0018] The power control circuit 73, of known type, is arranged to receive power supply from the battery 71, to store it, for instance through one or more capacitors, and to supply electric power, in the form of electric voltage, to pilot circuit 74, even if the voltage of the battery 71 varies, for instance between 3V and 2V.

[0019] The pilot circuit 74 comprises, for instance, a timer circuit (bistable) 81 having two timers, powered by the power control circuit 73, a charge and discharge circuit (inductor) 85 connected to the LED 76 and apt to electrically power it, as it will be disclosed later on in detail, and, interposed between the bistable 81 and the inductor 85, a controller circuit 83, arranged to combine the frequencies generated by the bistable 81, as it will be disclosed later on in detail.

[0020] The two timer circuit 81, for instance comprised of a TLC556 type integrated circuit, is configured, according to a preferred embodiment, for generating two types of square waves having each a duty cycle settable in a predetermined way.

For instance, in case of use of the TLC556 integrated circuit, the types of square waves are settable, in known way, by means of suitable passive components (resistors and capacitors not evidenced in Figure 2), connected to the pins of the integrated circuit itself.

The square waves generated by the bistable 81, in the preferred embodiment, are for instance:

- a first square wave having a cycle of 1110 ms approximately corresponding to 51 square waves per minute, having an active component (TON) with 800 ms duration and a null component (TOFF) with 310 ms duration;
- a second square wave having a frequency of approximately 56 KHz.

[0021] The controller circuit 83 receives as input the square waves generated by the bistable 81 and is arranged to combine such square waves so as to generate as output a composite square wave signal in which, in

particular, the TON and the TOFF are frequency modulated by the second square wave.

The controller circuit 83, for instance, may be made, in a known way, of active (transistors) and passive components.

In the preferred embodiment, the controller circuit 83 is adapted to realise an "ANALOG AND" type function between the square wave having the 56 KHz frequency and the square wave having the 1110 ms cycle.

Thanks to such type of realisation, the output signal is not a continuous signal but, rather, a signal having, in particular, the active component TON modulated to a predetermined frequency, apt to allow, consequently, to save power supply energy in comparison to pilot circuits that provide in output the active component TON only.

[0022] The charge and discharge circuit (inductor) 85 receives as input the signal generated by the controller circuit 83 and is arranged to electrically powering with constant current the LED 76 according to predetermined power on and off time periods.

The charge and discharge circuit 85 may be obtained, for instance, by means of an inductive circuit, placed in parallel to the LED 76 and arranged to accumulate the active component TON for the duration thereof and to unload such an accumulated active component in the time period corresponding to that of the null component TOFF, in the form of supply of constant current to the LED 76.

In the preferred embodiment, the power on time period of the LED will be 310 ms and the power off time period will be 800 ms.

[0023] The emergency indicator 5 (Fig. 1 and Fig. 2), as disclosed is therefore arranged to overcome the problems of the background art and provides, inter alia, the following features implementable singularly or altogether:

- it is apt to be self floating because, preferably, it is realised with light-weight materials and protected against water infiltration through the use of sealing rings, rather than through the use of resin impregnation;
- it complies with aid lights standards as, according to the disclosed embodiment, it is arranged to guarantee, for instance:
 - high autonomy of operation, for instance at least 24 hours autonomy, thanks to the disclosed pilot circuit 74;
 - high light emissions, for instance greater than 0,75 cd, in particular thanks to the LED 76;
 - light emission in a wide area, for instance a light emission in the whole upper hemisphere, thanks to the dome 24;
 - automatic power on, for instance, if in contact with marine water, thanks to the sensor 61;
 - predetermined flashing frequency, for instance more than 50 flashes per minute.

[0024] In a particularly preferred embodiment the switch 40 comprises a jack plug 41 (Fig.3a and Fig.3b), secured to the body 20 (Fig.1), and a mobile element (female element) 43 (Fig.3a and Fig.3b) arranged to slide along the jack plug 41 inside the shell 20.

[0025] The jack plug 41, for instance a stereo type jack plug, known per se, comprises electrically insulated parts, in the exemplified figures three electrically insulated parts (a, b, c) .

The mobile element 43 is arranged to take a first position (Fig.3a) in which the jack plug 41 is "unplugged" from the mobile element 43 and a second position in which the jack plug 41 is "plugged" into the mobile element 43.

The mobile element 43 of the switch 40, comprises, in particular, the sealing ring 22b that is shaped so as to prevent water or humidity infiltration when the mobile element 43 slides into the shell 20.

The mobile element 43 is shaped, for instance, so as to:

- keep activated the electrical connection between a first wire A1 and a second wire A2, by means of a conductive tongue A3, if the jack plug 41 is in "unplugged" position (Fig.3a), because the jack plug 41 is not interposed between the wires A1, A2 and the tongue; and
- keep the electrical connection deactivated if the jack plug 41 is in "plugged" position, because the jack plug is interposed between the wires A1, A2 and the tongue A3.

Obviously, in alternative embodiments, the same effect could be obtained by inverting the jack plug positions.

Thanks to such an embodiment, the emergency indicator according to the present invention may comprise a very effective switch, because it is actuatable by means of instinctive movements, and being of low cost, because it is shaped for using a jack plug type particularly widespread in the market.

Obvious changes and variations to the above disclosure are possible, as regards dimensions, shapes, materials, components, circuit elements, connections and contacts, as well as details of circuitry, the described construction without departing from the scope of the invention as defined by the claims that follow.

Claims

1. An emergency indicator comprising:

- an electronic circuit (70) having at least one light emitting device (76) actuatable for signalling emergency situations through at least one intermittent light signal and at least one battery (71) for supplying electric power to said light emitting device (76), **characterised by**
- a shell (20) shaped so as to contain said electronic circuit (70) and comprising

- at least one first shell element (21);
 - at least one second shell element (23) arranged to be embedded in said first shell element (21);
 - at least one sealing element (22a) interposed between said at least one first shell element (21) and said at least one second shell element (23) and arranged to render said indicator (5) impermeable to water and adapted to be self floating.
2. Emergency indicator (5) according to claim 1, **characterised in that** said at least one sealing element (22a) is a sealing ring having a predetermined shape.
 3. Emergency indicator (5) according to claim 1, **characterised in that** said shell (20) is made of lightweight plastic material.
 4. Emergency indicator (5) according to claim 3, **characterised in that** said material is transparent polycarbonate.
 5. Emergency indicator (5) according to claim 1, **characterised in that** at least one among said at least one first shell element (21) or said at least one second shell element (23) comprises at least one transparent dome (24) apt to allow to see on at least one hemisphere the light signal emitted by said light emitting device (76).
 6. Emergency indicator (5) according to claim 1, **characterised by** a coupler device (30) comprising a clip (31) apt to co-operate with said shell (20) for allowing to hook said indicator (5) to a life belt or jacket.
 7. Emergency indicator (5) according to claim 1, **characterised by** a switch (40) connected to said electronic circuit (70) and manually actuatable from the outside of said shell (20) for activating and/or deactivating operation of said indicator (5).
 8. Emergency indicator (5) according to claim 7, **characterised in that**:
 - said switch (40) comprises
 - a fixed element shaped as a jack plug (41), and
 - a mobile element (43) shaped so as to activate and/or deactivate said operation of said indicator (5) when sliding in said shell (20) from a first position to a second position along said jack plug (41); and **in that**
 - said mobile element (43) is associated to a sealing element arranged to render said indicator (5) impermeable to water.
 9. Emergency indicator (5) according to claim 8, **characterised in that**:
 - said jack plug (41) is a stereo type jack plug.
 10. Emergency indicator (5) according to claim 1, **characterised by** a sensor device (61) connected to said electronic circuit (70) and arranged to automatically activate operation of said indicator (5) in case of contact of said sensor device (61) with predetermined types of liquids.
 11. Emergency indicator (5) according to any one of previous claims, **characterised in that** it comprises:
 - a pilot circuit (74) adapted to receive said power supply from said battery (71) and to generate an activation signal modulated to a predetermined frequency so as to activate lighting of said light emitting device (76).
 12. Emergency indicator (5) according to claim 11, **characterised in that** said pilot circuit (74) comprises:
 - a timer circuit (81) adapted to generate
 - a first square wave signal having a first predetermined cycle;
 - a second square wave signal having a second predetermined cycle much lesser than said first cycle;
 - a controller circuit (83) adapted to generate said activation signal on the basis of said first square wave signal and of said second square wave signal.
 13. Emergency indicator (5) according to any one of previous claims, **characterised in that** said at least one light emitting device (76) is a LED arranged to emit white light.
 14. Emergency indicator (5) according to any one of previous claims, **characterised in that** said battery is a dry lithium battery.

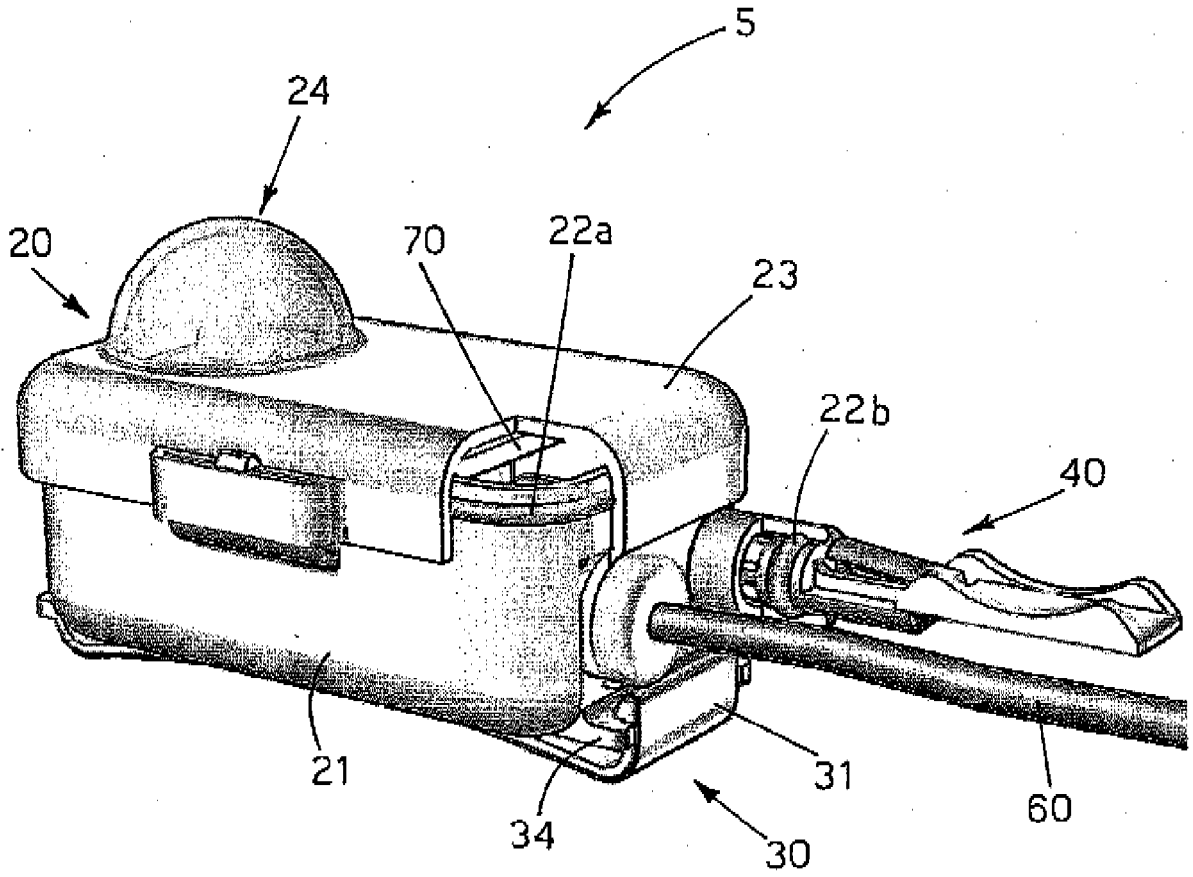

Fig. 1

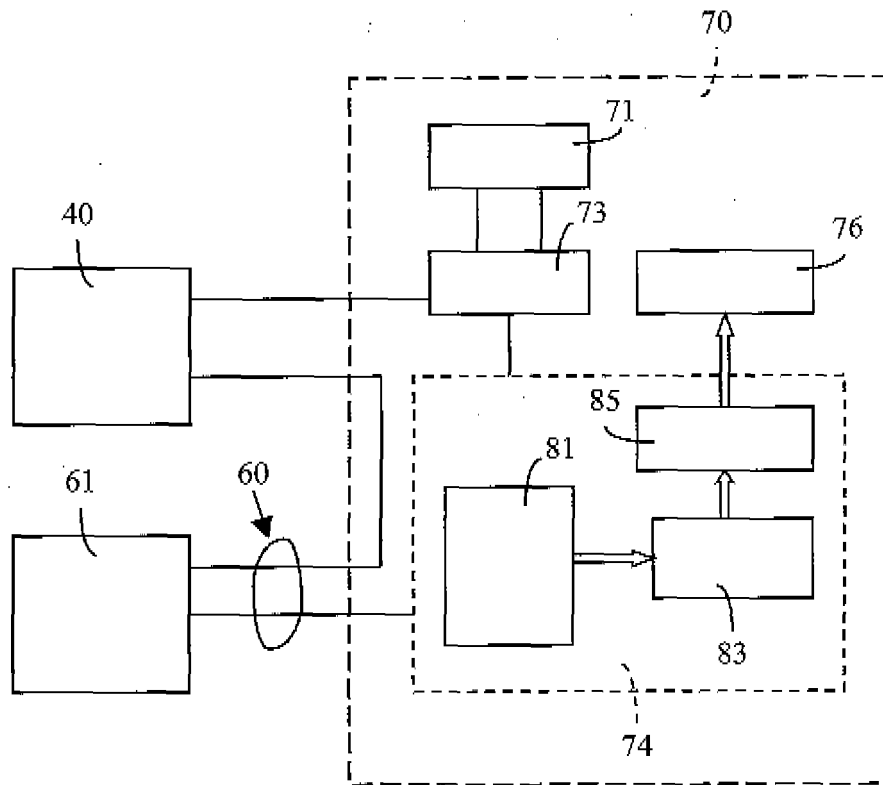

Fig. 2

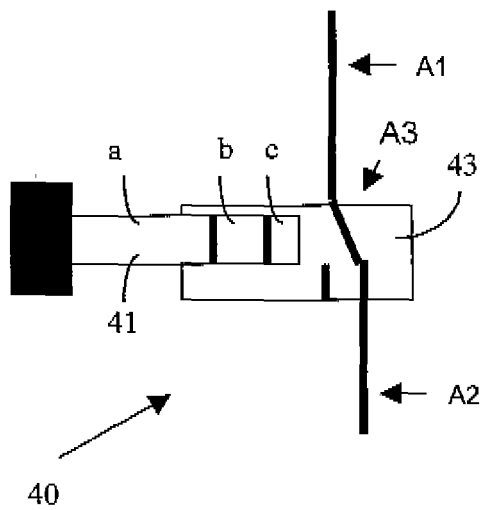

Fig. 3a

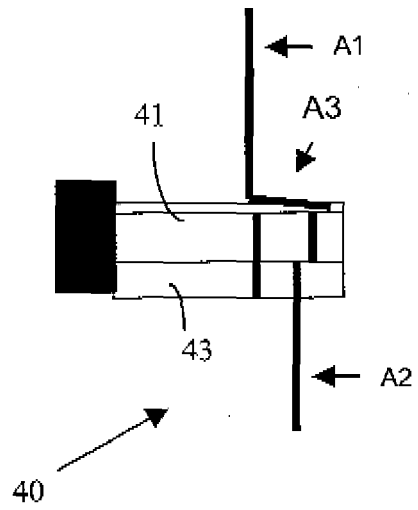

Fig. 3b