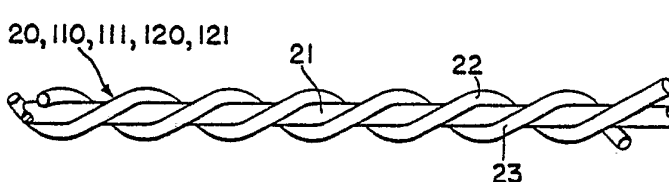

INTERNATIONAL APPLICATION PUBLISHED UNDER THE PATENT COOPERATION TREATY (PCT)

(51) International Patent Classification ³ : B60C 9/10	A1	(11) International Publication Number: WO 80/00069 (43) International Publication Date: 24 January 1980 (24.01.80)
<p>(21) International Application Number: PCT/US79/00311</p> <p>(22) International Filing Date: 10 May 1979 (10.05.79)</p> <p>(31) Priority Application Numbers: 916,271 916,270 916,272</p> <p>(32) Priority Dates: 16 June 1978 (16.06.78) 16 June 1978 (16.06.78) 16 June 1978 (16.06.78)</p> <p>(33) Priority Country: US</p> <p>(71) Applicant: THE GOODYEAR TIRE & RUBBER COMPANY [US/US]; 1144 East Market Street, Akron, OH 44316 (US).</p> <p>(72) Inventors: SCHMIT, Georges, Jean, Ernest; 35, Allee St. Hubert, Bridel (LU). WELTER, Thomas, Nicholas, Hubert; 65, Rue de Kehlen, Kleispelt (LU).</p>	<p>(74) Agent: KRUKOW, Carl, H.; 1144 East Market Street, Akron, OH 44316 (US).</p> <p>(81) Designated States: BR, DE (European patent), FR (European patent), GB (European patent), JP.</p> <p>Published with: <i>International search report</i></p>	
(54) Title: A COMPOSITE REINFORCEMENT CORD FOR REINFORCING ELASTOMERIC ARTICLES		
		
(57) Abstract		
<p>A composite cord for reinforcing a tire or other elastomeric article having at least one high strength, substantially inextensible yarn spirally wrapped around a core. The core at room temperature has sufficient strength and elasticity to resist and recover from tension forces on the core required during the processing of the cord and building of the tire. The core is composed of material which loses its tensile strength when subjected to temperatures of vulcanization to permit stretching out of the yarn to allow for substantial elongation of a part or all of the tire and then provide reinforcement of the elongated tire by the stretched out, high strength yarn.</p>		

FOR THE PURPOSES OF INFORMATION ONLY

Codes used to identify States party to the PCT on the front pages of pamphlets publishing international applications under the PCT

AT	Austria	LU	Luxembourg
BR	Brazil	MC	Monaco
CF	Central African Republic	MG	Madagascar
CG	Congo	MW	Malaŵi
CH	Switzerland	NL	Netherlands
CM	Cameroon	RO	Romania
DE	Germany, Federal Republic of	SE	Sweden
DK	Denmark	SN	Senegal
FR	France	SU	Soviet Union
GA	Gabon	TD	Chad
GB	United Kingdom	TG	Togo
JP	Japan	US	United States of America

A COMPOSITE REINFORCEMENT CORD FOR REINFORCING
ELASTOMERIC ARTICLES

Background of the Invention

The invention is directed to a composite reinforcement cord and elastomeric articles having at least one reinforcement made from said cord. The composite cord of
5 the present invention is similar to cords having a relatively weak core around which much stronger, inextensible yarns or cords are coiled, such that the composite cord has, initially, a low tensile modulus which abruptly changes to a substantially higher modulus
10 upon predetermined elongation of the cord. The cores of the tire cords used heretofore are typically composed of either a low tensile material such as a single strand of cotton, rayon, nylon or polyester, which is readily breakable, or a vulcanized elastomeric material which is
15 stretchable and allows the inextensible yarns to uncoil and straighten out during the toroidal shaping and molding of the tire.

The invention is directed to the provision of a composite, highly elongatable cord having a core which,
20 at room temperature under tension, has a barrier to elongation and elastic recovery. Further, the core is composed of material that loses its tensile strength when subjected to high temperature during the molding and vulcanization operations so as to permit elongation of
25 the yarns wrapped around the core.

Briefly stated, one form of the invention resides in a composite cord for reinforcing elastomeric articles such as tires. The composite cord comprises a plurality of substantially inextensible yarns which are spirally
30 wrapped around a core which has an elastic limit, at low elongation, sufficient to maintain the configuration of the cord during processing, but which loses its tensile strength during the molding and vulcanization of the elastomeric article to permit extension of the cord after
35 being subjected to the temperature of vulcanization.



-2-

The composite cord of the present invention is particularly well suited for a high-speed radial tire having a belt structure which consists of a pair of belt plies that are reinforced with cords made of a high modulus material, for example, brass-coated steel wires, and is designed to improve the handling and speed performance characteristics of such a tire, by avoiding deformation of the tread which generally occurs at higher speeds, and to reduce the ply steer effect, i.e., the lateral forces on the tire at zero degree slip angle. The invention is also advantageously used in tires with several or a number of belt plies which are reinforced with glass or aramid cords.

Another form of the invention resides in a radial tire having a belt structure comprising a pair of belt plies reinforced by cords. A carcass overlay is provided between the belt structure and carcass plies of the tire. The carcass overlay consists of a single ply with opposing marginal edges which extend laterally beyond the belt structure. The carcass overlay is reinforced with composite cords which extend substantially circumferentially of the tire. The cords of the carcass overlay are inextensible when the tire is toroidally shaped and vulcanized, but elongatable in correlated relation to the blow-up ratio of the tire from a generally cylindrical configuration to a toroidal shape.

The expression "blow-up ratio", as used herein and in the claims, means the ratio of the overall diameters of the carcass plies, when the tire is fully molded and vulcanized in a toroidal configuration, and when the carcass plies are in a cylindrical shape on a tire building drum.

Full size radial tires have been built with highly elongatable cords in the belt plies for allowing the original unvulcanized tire to be built in a cylindrical shape, rather than the more conventional toroidal shape in which radial tires are normally built. Foldable spare tires of the bias-belted type have also been made;

however, the same methods and constructions cannot be used to build a reduced diameter tire of the radial type because of the horrendous problems created by the radical difference between the cord angles of the reinforcement cords of the radial carcass plies and the cord angles of the cords in the belt structure. The invention may be applied to a method of making and the construction of a stretchable radial tire which, when deflated, is as small as the foldable spare tires of the prior art.

A modified form of the invention resides in a stretchable radial tire which is molded and vulcanized in a small, unstretched configuration and which is highly expansible upon inflation of the tire. This is made possible by the use, in the carcass plies and belt structure, of highly elongatable reinforcement cords previously discussed which initially have a relatively high modulus of elasticity and then after vulcanization a relatively low modulus of elasticity up to a predetermined elongation when the cords develop a relatively high modulus of elasticity and then after vulcanization of a relatively low modulus of elasticity up to a predetermined elongation when the cords develop a relatively high modulus of elasticity.

Description of the Drawing

The following description of the invention will be better understood by having reference to the annexed drawing, wherein:

Fig. 1 is a section of an inflated tire mounted on a wheel rim, illustrating certain uses of the composite cord of the invention and the tire being shown in the deflated condition in a chain-dotted line.

Fig. 2 is a view of a composite cord made in accordance with the invention.

Fig. 3 is a diagram illustrating the termoplastic behavior of the core of the composite cord of Fig. 2;

Fig. 4 is a stress-strain diagram of the composite cord of Fig. 2, prior to subjecting the cord to temperatures above 120° C.; and

5 Fig. 5 is a stress-strain diagram of the composite cord of Fig. 2, after the cord has been subjected to temperatures up to 156° C.

Fig. 6 is a section of another tire mounted on a wheel rim, the tire being in the inflated condition and made in accordance with the invention;

10 Fig. 7 is a section of the tire and wheel rim, of Fig. 6 illustrating the unstretched tire in the molded shape of reduced diameter mounted on the wheel rim;

15 Fig. 8 is a section of the tire of Fig. 6 shown in an alternative molded and vulcanized shape, prior to mounting on the wheel rim;

Fig. 9 is an enlarged fragmentary plan view of the belt plies and carcass plies of the vulcanized tire of Fig. 8 with parts being broken away to show the direction of the cords in the plies;

20 Fig. 10 is a cross section of yet another tire made in accordance with the invention;

25 Fig. 11 is a plan view of the tire of Fig. 10 with the tread removed to show the cord angle relationship between the reinforcement cords of the carcass plies, belt structure, and carcass overlay.

Detailed Description

Referring more particularly to Fig. 1, there is shown a tire 5 which is mounted and inflated on a wheel rim 6. The tire 5 comprises a fluid impervious innerline innerliner 7; at least one carcass ply 8, including a layer of reinforcement cords 9, adjacent the innerliner 7; and a tread 10 and pair of sidewalls 11 and 12 which surround the carcass ply 8 and terminate at a pair of annular metal beads 13 and 14. A belt structure 15, comprising a pair of superimposed belt plies 16 and 17 is positioned between the tread 10 and carcass ply 8 to reinforce the tire 5. A carcass overlay, or belt

-5-

underlay 18, in the embodiment illustrated, is interposed between the belt structure 15 and carcass ply 8. The tire 5 is preferably of the radial type wherein the reinforcement cords 9 of the carcass ply 8 are disposed at angles of from 75 to 90 degrees measured in relation to a plane containing the mid-circumferential centerline of the tread 10, such plane hereafter referred to as the centerplane. The belt plies 16 and 17 of the tire 5 are reinforced with cords disposed at angles in the range of from 16 to 24 degrees relative to the centerplane. The cords of the belt plies 16 and 17 cross the centerplane in opposite directions. The cord angles of the belt plies 16 and 17 are the same, but lie in opposite directions from the centerplane. The cord angles are in relation to a tire which is molded, vulcanized and uninflated. The tire 5 may also be of a radial type designed to be molded with a smaller diameter than the inflated tire, shown in a chain-dotted line adjacent the wheel rim 6, which is described in further detail hereinafter.

Referring now to Fig. 2, there is shown a composite cord 20 which is utilized to reinforce various components of the tire 5, e.g. the carcass ply 8, the belt structure 15, or the carcass overlay 18. The composite cord 20 comprises a core 21 with a spiral or helical wrapping of one or more substantially inextensible yarns 22, 23.

The core 21 is of a low molecular weight polymeric material selected from the group comprising polyolefines including polyethylene and polypropylene. A particularly good core 21 was found to be a polymeric monofilament of polyethylene or polypropylene having a density in the range of from 0.9 to 1.0 grams per cubic centimeter (gr/cm^3). The core 21 at room temperature may have an elastic limit of at least 2.5 kilograms and preferably of at least 1.5 grams per denier (gr/dn), a breaking strength less than 20 kilograms, and an initial modulus of elasticity of at least 25 grams per denier in the load range of from 0 to 2.5 kilograms.

The core 21 is degradable at temperatures normally used to vulcanize rubber which are usually over 120° C. and in the broad range of from 120° C. to 150° C., and in the preferred narrower range of from 130° C. to 140° C. After the core 21 is subjected to these elevated temperatures, the modulus of elasticity is reduced to 4 grams per denier or less and remains at the reduced amount when it is cooled to lower temperatures such as the outside temperatures at which a tire is used. The tenacity of the core 21 is also reduced to zero or a negligible amount of around 1 gram per denier after the core is subjected to these temperatures. It is not entirely understood but it is believed the loss in tensile strength of the core 21 results from a partial or total loss of crystalline structure to induce molecular slips upon the application of stress.

The core 21 described above consists of one filament; however, in some applications it may be desirable to have more than one filament, for example, three. The core 21 may be coated with a rubberized compound before the yarns 22, 23 are wound around the core. It may also be desirable to use a stapled polymer monofilament similar to cotton filaments which is completely coated with a rubberized compound before it is incorporated into the cord 20 to provide improved adhesion with the yarns 22, 23 of the cord.

The yarns 22, 23 which are spirally wrapped in the form of a helix around the core 21, may be composed of any suitable reinforcing material which is used for conventional tire reinforcement cords having a tenacity of at least 6 grams per denier. Among these materials are rayon, nylon, polyester, aramid and steel. Each of the yarns 22, 23 is formed of at least one strand that is composed of filaments which are twisted around each other. Yarns 22, 23, composed of one strand having a denier in the range of from 800 to 1500 and helically wrapped around the core 21 in either an S- or Z-direction at a rate of from 3 to 7 turns per centimeter, were

successfully used to form a good composite cord 20 which was elongatable between 50 percent and 100 percent. The yarns 22, 23 may also be composed of a plurality of strands which are cabled together, generally in a
 5 direction which is opposite that which the filaments of each strand are twisted.

Example of a Composite Cord

10 A good composite cord 20 comprises a core 21 which is a monofilament that is composed of polyethylene having a density of 0.96 gr/cm^3 at room temperature of about $20-22^\circ \text{ C}$.

15 Two substantially inextensible yarns 22, 23 are spirally wrapped around the center core 21 in opposed lay. The yarns 22, 23 are each formed of a single, 1500 denier strand which is composed of filaments of aramid twisted together. The twist in the individual strands or yarns 22,23, in this case, is in a Z-direction at a rate of 2.5 turns per centimeter. The twist of the
 20 yarns 22,23 around the core 21 is in an S-direction at a rate of 6 turns per centimeter. Due to the mutually opposed lay of the yarns 22,23 around the core 21, the yarns 22,23 will, during elongation of the composite cord 20 after subjecting the core 21 to a temperature used for vulcanization, twist into a single twisted
 25 cord of the type conventionally used in the reinforcement of tires.

The polyethylene monofilament core 21 of this example has the following properties at room temperature:

30	density	0.96 gr/cm^3
	diameter	0.50 mm
	breaking strength	10 kg
	elastic limit	9 kg
	Young modulus at 2.5 lg	75 gr/dn
35	elongation at elastic limit	17%
	elastic recovery at 3% elongation	90%
	denier	1700



Referring to Fig. 3, the thermoplastic behavior of the polyethylene monofilament core 21 is charted as a function of the breaking strength in kilograms vs. the temperature in degrees centigrade. More specifically, Fig. 3 shows the breaking strength of the core 21, after 5 minutes of heat treatment at the respective temperatures. As can be appreciated from Fig. 3, the breaking strength of the polyethylene core 21 remains unaffected by the temperature up to about 122° C. at which temperature the breaking strength starts to decrease. By processing at higher temperatures the breaking strength of the core 21 is further reduced and at about 142° C. the breaking strength is reduced to substantially zero. Thus, it will be appreciated that the polyethylene monofilament core 21 will not lose its original tensile resistance during processing of the cord 20, if it is not subjected to temperatures above 120° C. On the other hand, it will be appreciated that the core 21, when embedded in a tire 5, will, unlike cores of prior art cords, lose its tensile resistance during vulcanization of the tire which is normally carried out at about 150° C.

Referring now to the stress-strain diagram of Fig. 4, the cord 20 with the polyethylene monofilament core 21 passes through three phases or stages. First, there is an initial high modulus phase A-B which the cord 20 experiences as the core 21 stretches to the point where it loses its tensile resistance. Secondly, the cord 20 passes through a low modulus phase C-D where the inextensible yarns 22,23 are stretched out and the tensile strength of the cord gradually increases. Thirdly, the cord 20 passes through the final, high modulus phase D-E where the uncoiled yarns 22,23 are twisted and tensioned until they break at point E.

It will be appreciated that the initial region A-B forms a barrier to appreciable elongation of the cord 20 for tensiles up to around 12 kilograms. Within this barrier, the cord 20 has a high modulus

-9-

and high elastic recovery. Thus, in consequence of this barrier, the cord 20 has sufficient strength to resist and recover from any tensional forces imparted to the cord during its processing or the processing of tire components reinforced with such cords, before the shaping and vulcanization of a tire composed of such components.

A typical processing of the cord 20 includes mechanical and thermal stresses, the latter being experienced by the cord as it is exposed to temperatures of from 100° C. to 120° C. to dry the cord, after it has been coated with a resorcinol formaldehyde type adhesive for promoting the bond between the cord and rubbery material used in the production of tires.

Referring now to the stress-strain diagram of Fig. 5, the same cord 20 with the polyethylene monofilament core 21 has lost its tensile resistance after it has been subjected to 15 minutes of heat treatment at 150° C. The elongation barrier A-B of the cord 20, when unheated, as seen in Fig. 4, substantially disappears. There is only a low modulus substantially linear region A'-D' corresponding to the high elongation of the cord 20 as the yarns 22,23 stretch out, and then a high modulus phase D'-E' corresponding to the extension of the twisted yarns.

It will be understood that with the cords 20 of the present invention a relatively high elongation may be easily obtained. It takes relatively little effort or work to stretch out the cords 20 to their full extent, because the core 21 offers little or no resistance to the stretching out of the individual yarns 22, 23, of each cord after being subjected to temperatures normally used for vulcanization.

Thus, it can be appreciated that the composite tire cord 20 of the invention provides a substantial advantage over prior art composite cords in that it has an initial, elastic, high modulus elongation barrier providing sufficient resistance and recovery of the cord with respect to any processing tensions experienced.

BUREAU

OM-77
UNDA

-10-

by the cord before shaping and vulcanization of the tire, whereas after vulcanization of the cord has no such barrier and may be elongated with a minimum of effort.

The composite cord 20 of the invention is particularly well suited for use in a radial spare tire, illustrated in Fig. 6, wherein there is shown an expandable, spare radial tire 105 mounted on a wheel rim 106 in the inflated extended condition. The spare radial tire 105 essentially comprises a fluid impervious inner-liner 107 disposed within a plurality of carcass plies 108,109 which are reinforced with parallel cords 110,111; a tread 112 and pair of sidewalls 113, 114 surrounding the carcass plies 108, 109 and terminating at a pair of annular inextensible cable beads 115, 116 comprising cabled wires. A belt structure 117, consisting of a pair of superimposed belt plies 118, 119 is interposed between the tread 12 and radially outermost carcass ply 109.

As shown in Fig. 9, the belt plies 118,119 are reinforced with parallel cords 120,121 which cross and extend in opposite directions from a plane CP containing the mid-circumferential centerline of the tread 112. The reinforcement cords 120,121 of the belt structure 117 are disposed at angles a and b in the broad range of 0° - 30° and preferably the narrower range of 10° - 25°, measured relative to the centerplane CP when the tire is vulcanized and deflated. The reinforcement cords 110,111 of the carcass plies 108,109 are radially oriented between the tire beads 115,116, i.e., they are disposed at angles d in the range of 75° - 90° measured relative to the centerplane. The rubber material of the carcass plies 108,109 and belt plies 118,119 is preferably a soft, low modulus compound having a modulus of elasticity smaller than 15 MPa (Mega Pascal) or 150 kp/cm² and preferably smaller than 10 MPa or 100 kp/cm² at 100 percent elongation.

The reinforcement cords 110,111 of the carcass plies 108,109 and 120,121 of the belt structure 117 have the

BUREAU
OF
WIPO

-11-

same structure as composite cords 20 illustrated as best seen in Fig. 2, each characterized by having a relatively high modulus of elasticity during the processing of the cord and the building of the tire.

5 After the cords are subjected to vulcanization temperatures, they develop a low modulus of elasticity and are highly elongatable up to a predetermined length when they again develop a high modulus of elasticity and have a high resistance to elongation. The core 21
10 of cord 20 provides the cord strength to maintain the inextensible yarn 22,23 in helical relation during any processing of the cord such as dipping, calendering, or building of the tire 5.

The expandable spare radial tire 105 may be built
15 by placing the aforementioned components 107-121 on a conventional cylindrical tire building drum, to build an unvulcanized tire 105 which is axially smaller than normal. The unvulcanized tire 105 is then shaped, molded and vulcanized in the radially smaller than normal
20 operating configuration illustrated in Fig. 8 where the tread 112 and upper sidewalls 128,129 are generally cylindrical and the remaining, major portions of the sidewalls 113,114 diverge from the tread 112 in directions away from the centerplane CP of the tire 105. Alter-
25 natively, the unvulcanized tire 105 can be molded and vulcanized in the deflated configuration with the sidewalls 128,129 generally U-shaped as illustrated in Fig. 7.

The vulcanized spare tire 105 is then mounted on
30 the wheel rim 106 as best seen in Fig. 7, where the outer diameter of the tire is adjacent the wheel rim 106. After vulcanization the core 21 of each of the cords 110, 111, 120 and 121 has a reduction in tensile strength of from 10 kilograms to zero or a negligible amount and
35 consequently the modulus of elasticity of the cords is greatly reduced. This permits stretching out of the yarns 22,23 so that upon inflation with air, the spare tire 105 stretches toroidally to a regularly sized tire



-12-

which the spare tire 105 is designed to replace. The cords 110,111, 120 and 121 develop a high modulus of elasticity when the yarns 26,27 are stretched out a predetermined amount at which point the tire 105 is expanded to the size of a regular tire. The cords 110,111,120 and 121 therefore provide the necessary reinforcement for the inflated expanded tire.

It should be apparent from the above description that during vulcanization, the core 21 degrades and the elongation barrier A-B of Fig. 4 disappears. Therefore, after vulcanization, the tire 105 is easily expanded to its normally inflated and running condition as the yarns 22,23 are readily elongated and twist into twisted reinforcing cords.

Thus, there has been described an expandable spare radial tire when, upon inflation with air, is stretchable from a deflated storage position on the wheel rim to an expanded condition where the spare tire resembles, in size, the tire it is replacing on the automobile.

The composite cord 20 can also be utilized in the carcass overlay as shown in Figs. 110. With reference to Fig. 10, there is shown a tire 205 having a carcass overlay 218 made from the composite cords 20. The tire essentially comprises: a fluid impervious innerliner 206; at least one carcass ply 207 surrounding the innerline 206; a tread 108 and pair of sidewalls 209,210 surrounding the carcass ply 207 and terminating at a pair of annular, inextensible beads 211,212; and a belt structure 213 interposed between the carcass ply 207 and tread 208.

The carcass ply 207 (Fig. 10) is reinforced with parallel cords 214 which are radially oriented, i.e. disposed at angles A in the range of from 75 to 90 degree degrees measured in relation to a plane CP containing the mid-circumferential centerline of the tread 208, The reinforcement cords 214 of the carcass ply 207 is composed of any suitable material, e.g., rayon, polyester, glass fibers, aramid, or metal.

5 The belt structure 213 (Fig. 10) comprises two
belt plies 215,216 which are in superimposed relation and
reinforced, respectively, with parallel cords 217,218
that are disposed at angles B,D greater than 15 degrees
and preferably in the range of from 15 to 30 degrees
measured from the centerplane. The reinforcement cords
217,218 of the two belt plies 215,216 extend in different
directions from the centerplane, although the cord angles
of the reinforcement cords 217,218 are generally the same
10 in this embodiment are both around 20 degrees. The
reinforcement cords 217,218 of the belt structure 213
are inextensible and composed of any suitable material
such as aramid, glass, or metal, e.g. preferably brass-
coated steel wire.

15 A belt underlay, or carcass overlay 220 is inter-
posed between the belt structure 213 and carcass ply
207. The carcass overlay 220 is adjacent to the carcass
ply 207 and has lateral marginal edges 221,222 which
extend beyond the belt structure 213 into the sidewalls
209,210 of the tire 205, but terminate short of the
20 maximum flex zones, or areas 223,224 of the sidewalls
209,210. The maximum flex zones 223,224 are normally at
the thinnest sections of the sidewalls 209,210. The
maximum flex zones 223,224 are normally at the thinnest
25 sections of the sidewalls 209,210 of the tire 205, such
sections usually being at about the maximum width or
section diameter SD of the tire 205. The carcass over-
lay 220 (Fig. 10) consists of a single ply which is
reinforced with parallel cords 225 that extend substan-
30 tially circumferentially of the tire 205, i.e., at cord
angles E in the range of from 0 to 13 degrees relative
to the centerplane. The carcass overlay 220 has no
effect on ply steer, i.e., the tendency of the tire
construction to move the tire in a lateral direction,
35 when the reinforcement cords 225 thereof are at very low
angles of about zero degrees. The carcass overlay 220
has a decided effect upon the reduction of ply steer
when the reinforcement cords 25 are disposed at angles

-14-

of 4 degrees or more, and preferably around 8 degrees which seems to be the optimum cord angle for eliminating ply steer without seriously affecting the restrictive effect of the low angle reinforcement cords 225. Thus, the preferred cord angles of the reinforcement cords 225 are in the more selective range of from 4 to 13 degrees relative to the centerplane. The reinforcement cords 225 of the carcass overlay 220 extend in the same general direction from the centerplane as do the reinforcement cords 217 of the nearest belt ply 215.

The tire 205 is built by flat building a band of the carcass 207 and the carcass overlay 220 by wrapping the carcass ply 202 and the overlay 220 successively around a cylindrical tire building drum. This band, when removed from the drum has a cylindrical shape wherein the reinforcement cords 225 of the carcass overlay 220 are elongatable in corresponding relation to the blow-up ratio of the tire. This band is then shaped to a toroidal configuration for receipt of the belt structure 213, whereafter the tire 205 is molded and vulcanized. The reinforcement cords 225 of the carcass overlay 220 are substantially inextensible, when the band is fully shaped in the toroidal configuration and when the tire 205 is completely molded and vulcanized.

An appropriate cord 225 for the reinforcement of the carcass overlay 220 is of the composite cord 20 type illustrated in Fig. 2 and described hereinafter. The cord 225 is comprised of 4 yarns which are wound continuously at 5.5 turns per centimeter around a 0.5 millimeter diameter cotton core of 2.5 kilograms tensile at break, each of the yarns being composed of filaments of nylon twisted together at a rate of 5 turns per centimeter to form a yarn of 840 denier, the overall cord diameter being 1.2 millimeters. Another example of a reinforcement cord 225 is one having a 0.5 millimeter cotton core with a spiral wrapping of 2x1500 aramid yarns at 6 turns per centimeter, the overall cord diameter being 1.2 millimeters.

BUREAU
OMP
WIPG

A cushion 229, composed of a separate layer of soft, highly resilient, rubber material is, preferably, positioned between the carcass overlay 220 and nearest belt ply 215. The rubber material of the cushion 229 should have an elasticity, defined at 100 percent elongation, which is at least 100 grams per square millimeter less than that of the rubber material of the carcass overlay 220 and nearest belt ply 215.

It has been found from the typical stress-strain plots of the cords that a large variety of passenger tire sizes with blow-up ratios in the range from 155-195 percent can be made by using a cord of the present invention with elongation in the range of 70-90 percent. This is, therefore, a preferred range of elongatability for this particular type of tire with the aforementioned blow-up ratio. It will be obvious that without leaving the scope of this invention, other such preferred ranges can be easily found by one skilled in the art for other tire sizes with other blow-up ratios.

Thus, there has been described a radial tire having a two-ply belt structure in combination with a special carcass overlay for achieving highly improved high-speed characteristics. Further, a resilient cushion of rubber can be provided between the carcass overlay and belt structure to provide an uncoupling action between these two components and to facilitate reorientation of the cords during the molding and vulcanization of the tire. Any of the aforementioned cord angles are in relation to a fully molded and vulcanized tire which is uninflated.

Thus, it can be appreciated that all of the reinforcement cords used in rubber articles, e.g. tires, can be of the composite type, as described or in individual components of the tire, such as the belt, structure, carcass structure or carcass overlay.



Thus, there has been described various tire constructions that are reinforced with composite cords composed of substantially inextensible yarns which are spirally wrapped around a core of polyethylene or polypropylene that loses its tensile strength during the molding and vulcanization process, thereby allowing elongation of the composite cores as the individual yarns stretch out.

It will be clear that the cord of the present invention may also be used in articles other than tires without departing from the scope of the present invention.

-17-

Claims

1. A composite cord for reinforcing an elastomeric article, said cord comprising at least one high tenacity substantially inextensible yarn spirally wrapped around a core, said core including at least one filament having
5 at room temperature an elastic limit of at least 2.5 kilograms and a modulus of elasticity greater than 25 grams per denier to resist and recover from tension forces on the cord during the processing of said cord and elastomeric article and said core having a reduction in
10 tenacity after being subjected to temperatures normally used during vulcanization of rubber to permit stretching out of said yarn when said core is cooled to allow for elongation of the elastomeric article and then reinforcing of the article in the elongated condition
15 when said yarn is stretched out.

2. The composite cord for reinforcing an elastomeric article of claim 1, said elastomeric article comprising a tire having at least one part reinforced with a
20 plurality of said composite cord.

3. The composite cord for reinforcing an elastomeric article of claim 1 or 2 wherein said temperatures normally used during vulcanization are in the
25 range of 120° C. to 150° C.

4. The composite cord for reinforcing an elastomeric article of claim 1 or 2 wherein the core of said cord is composed of a polymer of the group consisting of polyolefines.
30

5. The composite cord for reinforcing an elastomeric article of claim 4 wherein said polyolefines include polyethylene and polypropylene.

BUREAU
OMPI

-18-

6. The composite cord for reinforcing an elastomeric article of claim 1 or 2 wherein the core of said cord is a monofilament.

5 7. The composite cord for reinforcing an elastomeric article of claim 1 or 2 wherein the core of said cord has an elastic limit of at least 1.5 grams per denier before being subjected to said temperatures normally used during vulcanization.

10 8. The composite cord for reinforcing an elastomeric article of claim 3 wherein the core of said cord has said reduction in tenacity at a temperature in the range of from 130° C to 140° C.

15 9. The composite cord for reinforcing an elastomeric article of claim 1 or 2 wherein said yarn of said cord is composed of at least one twisted strand which is composed of filaments of reinforcing material.

20 10. The composite cord for reinforcing an elastomeric article of claim 9 wherein said yarn of said cord is composed of said strand cabled together with other strands.

25 11. The composite cord for reinforcing an elastomeric article of claim 9 wherein said strand has a denier in the range of from 800 to 1500.

30 12. The composite cord for reinforcing an elastomeric article of claim 1 or 2 wherein a second substantially inextensible yarn of high tenacity is spirally wrapped around said core of said cord in opposed relation to said first yarn so that after said reduction in tenacity of said core and elongation of said cord
35 said first and second yarns will twist together.



13. The composite cord for reinforcing an elastomeric article of claim 1 or 2 wherein said yarn of said cord is wound around the core in the range of from 3 to 7 turns per centimeter and said cord is elongatable between 50 percent and 100 percent.

14. A composite cord for reinforcing an elastomeric article, said elastomeric article comprising a stretchable tire, said stretchable tire comprising:

(a) at least one carcass ply reinforced with radially oriented cords disposed at angles in the range of from 75-90 degrees relative to a centerplane containing the mid-circumferential centerline of the tread of the tire, when the tire is molded, vulcanized and uninflated, said cords of said carcass ply being highly elongatable in an amount of from 50 to 100 percent to allow for toroidal expansion of the tire;

(b) a fluid impervious innerliner disposed within said carcass ply;

(c) a tread and pair of sidewalls surrounding said carcass ply and terminating at a pair of annular beads;

(d) at least one belt ply of cords interposed between said carcass ply and tread for annularly reinforcing the tire, said cords of said belt ply being disposed at angles in the range of from 0-30 degrees, measured from said centerplane, and also being highly elongatable in an amount of from 50 to 100 percent to allow for circumferential expansion of the tread upon inflation of the tire;

(e) each of said reinforcement cords of said carcass ply and said belt ply consisting of a central core and at least one inextensible yarn spirally wrapped around said core, the tensile strength of said core being sufficient to maintain said inextensible yarn in helical relation during building of the tire; and

(f) said core being of a material having a substantial reduction in tensile strength when subjected to temperatures of vulcanization of the tire to

elongation of said yarn after the tire is vulcanized.

15 15. The composite cord for reinforcing an elastomeric article of claim 14 wherein said core of said cord is composed of a polymer of the group of polyolefines.

16. The composite cord for reinforcing an elastomeric article of claim 14 wherein said polyolefines include polyethylene and polypropylene.

10 17. The composite cord for reinforcing an elastomeric article of claim 14 wherein said inextensible yarn of said cord consists of at least one twisted strand composed of filaments of material of the group of rayon, nylon, polyester, aramid and steel.

15 18. The composite cord for reinforcing an elastomeric article of claim 14 wherein said stretchable tire includes two carcass plies reinforced with radially oriented cords, and two belt plies of cords between the tread and radially outermost ply of said carcass plies, said cords of said belt plies crossing and being
20 disposed at identical cord angles measured in opposite directions from said centerplane.

19. The composite cord for reinforcing an elastomeric article of claim 14 wherein said cords of said carcass ply and belt ply are each characterized
25 after vulcanization by an initial low modulus of elasticity and high elongation and subsequent high modulus of elasticity and low elongation after said cords elongate a predetermined amount.

30 20. The composite cord for reinforcing an elastomeric article of claim 14 wherein said cords of said carcass ply and belt ply are embedded in rubber material having a modulus of elasticity less than 150 kp/cm² at 100 percent elongation.

35 21. The composite cord for reinforcing an elastomeric article of claim 14 wherein said core has a tensile strength of 10 kilograms prior to

vulcanization and said reduction in tensile strength at temperatures of vulcanization is from 10 kilograms to zero or a negligible amount.

5 22. A method of making an elastomeric article, said elastomeric article comprising a highly stretchable radial tire for use as an uninflated spare tire, said tire comprising:

10 (a) building an axially much smaller than normal unvulcanized, cylindrically shaped radial tire of highly stretchable components of an innerliner, at least one carcass ply with reinforcing cords, a tread, a pair of sidewalls, a pair of beads, and a belt structure comprised of at least one belt ply with reinforcing cords;

15 (b) molding and vulcanizing the tire in a radially much smaller than normal configuration with the components in an unstretched position where

 (I) the tread is generally cylindrical,

 (II) the sidewalls are each generally U-shaped,

20 and

 (III) the reinforcing cords of the carcass ply and belt structure are highly elongatable;

25 (c) each of said cords consisting of a central core and a spiral wrapping of at least one inextensible yarn, said core being sufficiently strong to maintain said inextensible yarn in helical relation during the formation of the components into an unvulcanized tire; and

30 (d) said core being of a material having a substantial reduction in tensile strength when subjected to temperatures of vulcanization of the tire to permit high elongation of said yarn after the tire is vulcanized.

35 23. A method of making an elastomeric article, said elastomeric article comprising a highly stretchable radial tire for use as an uninflated spare tire, comprising:

 (a) building an axially much smaller than normal

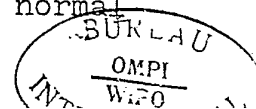

5 unvulcanized, cylindrically shaped radial tire of highly stretchable components of an innerliner, at least one carcass ply with reinforcing cords, a tread, a pair of sidewalls, a pair of cable beads, and a belt structure comprised of at least one belt ply with reinforcing cords;

(b) molding and vulcanizing the tire in a radially much smaller than normal configuration with the components in an unstretched position where

10 (I) the tread is generally cylindrical
(II) major portions of the sidewalls diverge from the tread in the direction away from the centerplane of the tire, and

(III) the reinforcing cords of the carcass ply and belt structure are highly elongatable;

15 (c) each of said cords consisting of a central core and a spiral wrapping of at least one inextensible yarn, said core being sufficiently strong to maintain said inextensible yarn in helical relation during the formation of the components into an unvulcanized tire; and

20 (d) said core being of a material having a substantial reduction in tensile strength when subjected to temperatures of vulcanization of the tire to permit high elongation of said yarn after the tire is vulcanized.

25

24. The method of claim 22 or 23 wherein the belt structure consists of two belt plies with said reinforcing cords.

30

25. The method of claim 22 or 23 wherein said components include a pair of carcass plies of said reinforcing cords.

35

26. The composite cord for reinforcing an elastomeric article said article comprising a tire having

(a) at least one carcass ply reinforced with cords which are radially oriented between beads of the tire;

(b) a tread and pair of sidewalls surrounding the

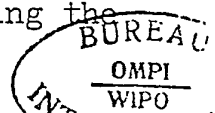

-23-

carcass ply and terminating at a pair of annular, inextensible beads;

5 (c) a belt structure interposed between the tread and carcass ply for annularly reinforcing the tire, the belt structure comprising a pair of belt plies in super-
imposed relation, each of the belt plies being reinforced by parallel cords disposed at angles greater than 15
degrees relative to a plane containing the mid-
10 circumferential centerline of the tread, the reinforcement cords of the plies extending in different directions from said plane; and

15 (d) a carcass overlay disposed between the carcass ply and belt structure, the carcass overlay consisting of a single ply with opposing marginal edges which extend laterally beyond the belt structure, the carcass overlay
being reinforced with parallel cords which are disposed at angles in the range of from 0 to 13 degrees relative
to said plane, the reinforcement cords of said carcass
20 overlay being substantially inextensible after the tire is toroidally shaped, and elongatable in corresponding relation to the blow-up ratio of the tire when the carcass and attached overlay are cylindrically shaped prior to toroidal expansion.

25 27. The composite cord for reinforcing an elastomeric article of claim 26 wherein the cords of said carcass overlay each have a high modulus, low tensile strength core, and at least one inextensible yarn spirally wrapped around the core, when the overlay
30 is laid in the unshaped tire.

28. The composite cord for reinforcing an elastomeric article of claim 26 wherein the cords of the carcass overlay and nearest belt ply extend in the
35 same general direction from said plane.

29. The composite cord for reinforcing an elastomeric article of claim 27 wherein the core of said

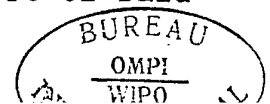

-24-

cords loses tensile strength when subjected to elevated temperatures.

5 30. The composite cord for reinforcing an elastomeric article of claim 26 wherein the cords of said carcass overlay are disposed at angles in the range of from 4 to 13 degrees relative to said plane.

10 31. The composite cord for reinforcing an elastomeric article of claim 30 wherein the cords of said carcass overlay are disposed at angles of around 8 degrees.

15 32. The composite cord for reinforcing an elastomeric article of claim 26 wherein marginal edges of the carcass overlay extend into the sidewalls and terminate short of the maximum flex zones of the sidewalls.

20 33. The composite cord for reinforcing an elastomeric article of claim 26 which includes:
a cushion disposed between the belt structure and carcass overlay, the cushion being composed of a separate layer of elastomeric material having an elasticity
25 which is at least 100 gr/mm^2 less than that of elastomeric material of which the carcass overlay and the belt ply adjacent said cushion are composed, the elasticity being defined at 100 percent elongation of said material.

30 34. The composite cord for reinforcing an elastomeric article of claim 27 wherein the core of said cord is composed of cotton and the spiral wrapping is composed of material of the group of rayon, nylon, polyester, aramid and metal.

35 35. The composite cord for reinforcing an elastomeric article of claim 26 wherein the cords of the carcass ply are composed of materials of the group of

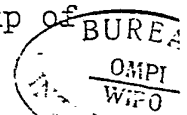

rayon, polyester, glass fibers, aramid, and steel.

5 36. The composite cord for reinforcing an e
elastomeric article of claim 26 wherein the cords of
said pair of belt plies are composed of materials of
the group of metal, aramid and glass.

10 37. The composite cord for reinforcing an elas
elastomeric article of claim 36 wherein the cords of
said pair of belt plies are composed of brass-coated
steel wires.

15 38. The composite cord for reinforcing an
elastomeric article of claim 27 wherein the tire has a
blow-up ratio in the range from 155-195 percent and the
cords of said carcass overlay are elongatable of from
70-90 percent when the overlay is in a cylindrical
configuration.

20 39. A method of making an elastomeric article
substantially as described herein or as shown in the
accompanying drawings.

25 40. A composite cord and/or elastomeric article
substantially as described herein or as shown in the
accompanying drawings.

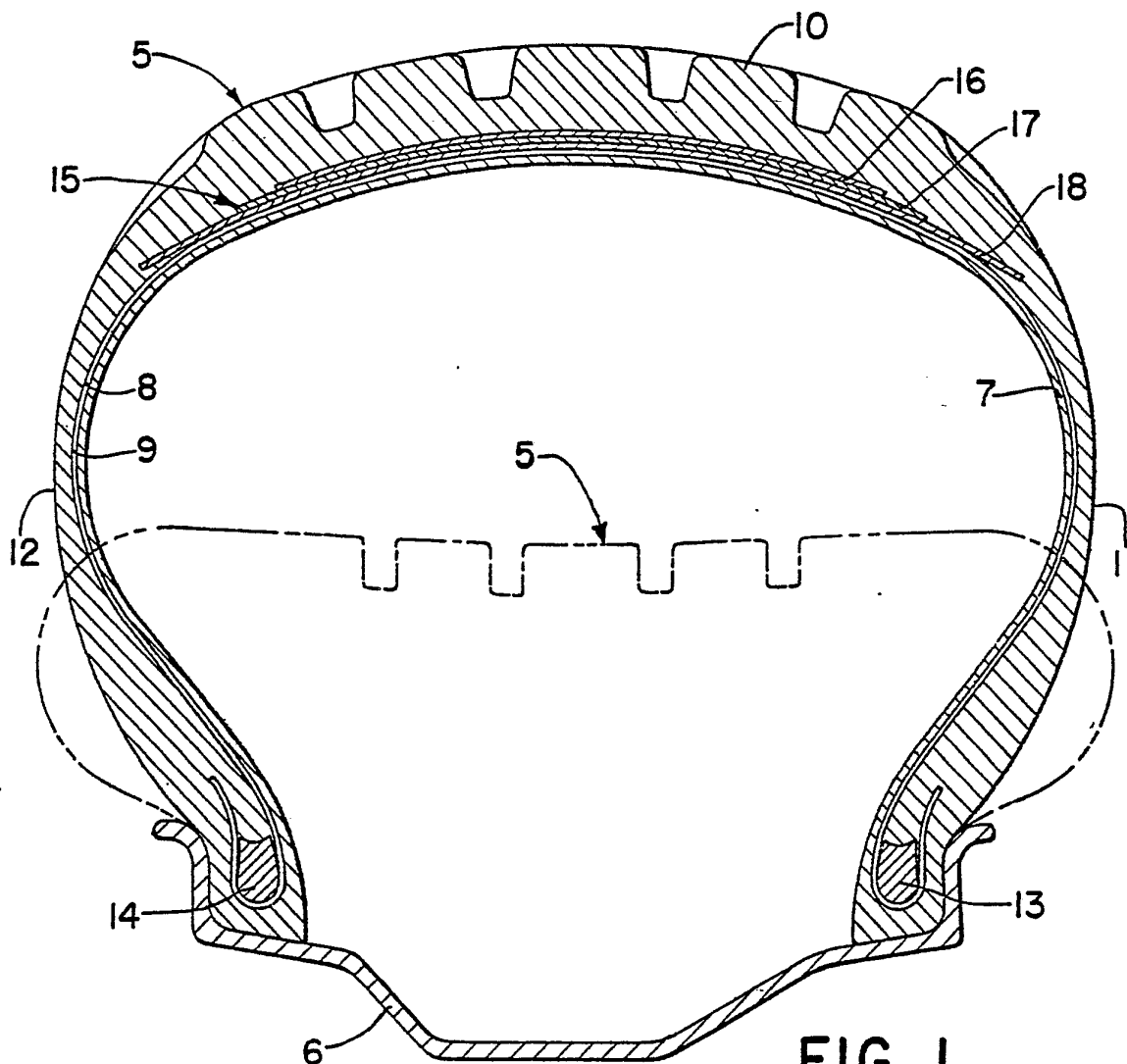

FIG. 1

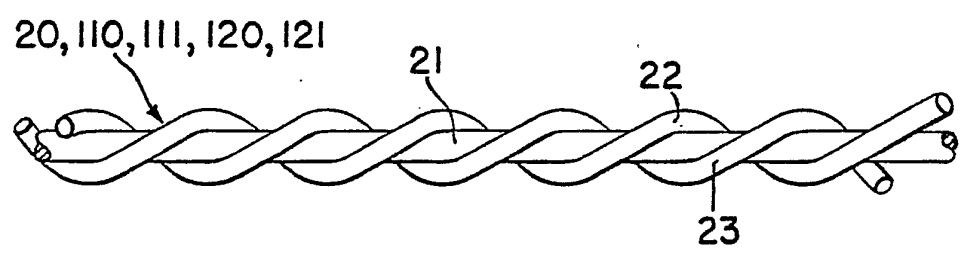

FIG. 2

2/5

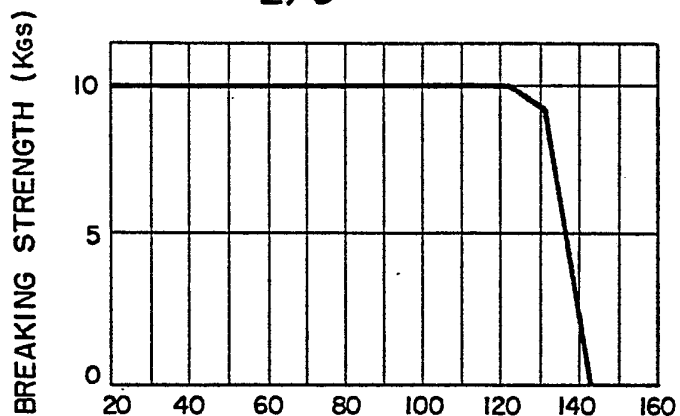

FIG. 3

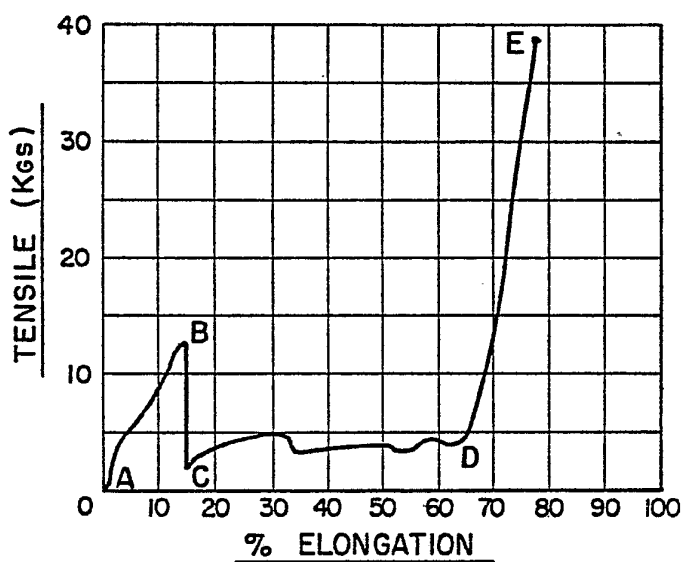

FIG. 4

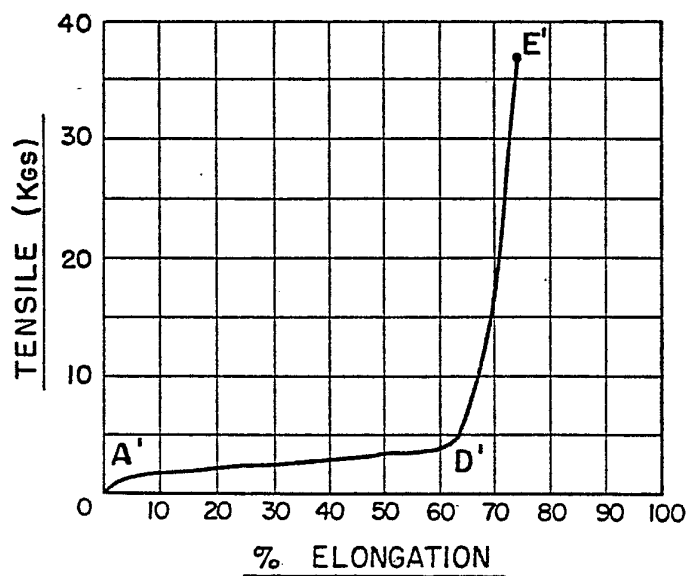

FIG. 5



3/5

FIG. 6

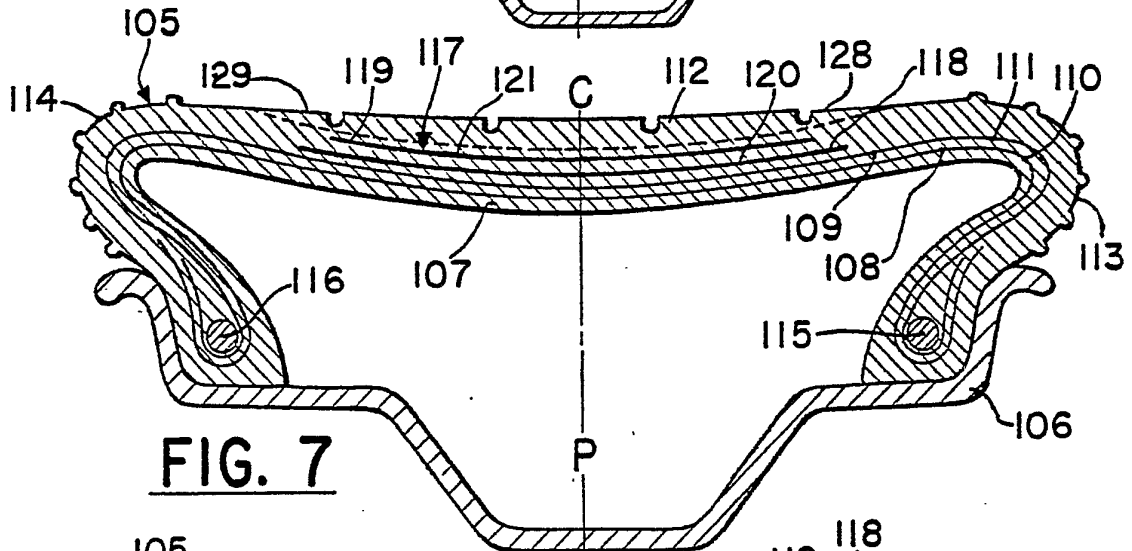
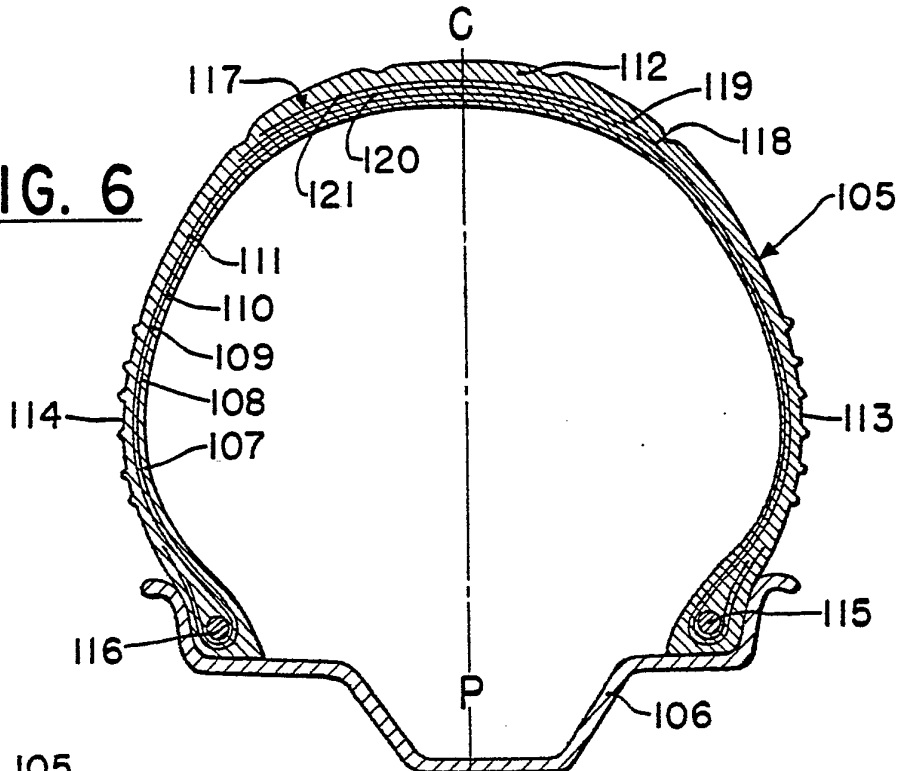

FIG. 7

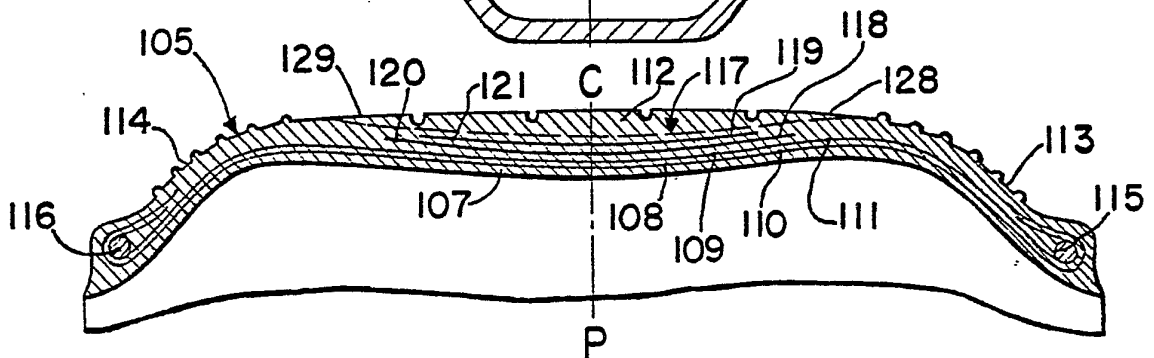

FIG. 8

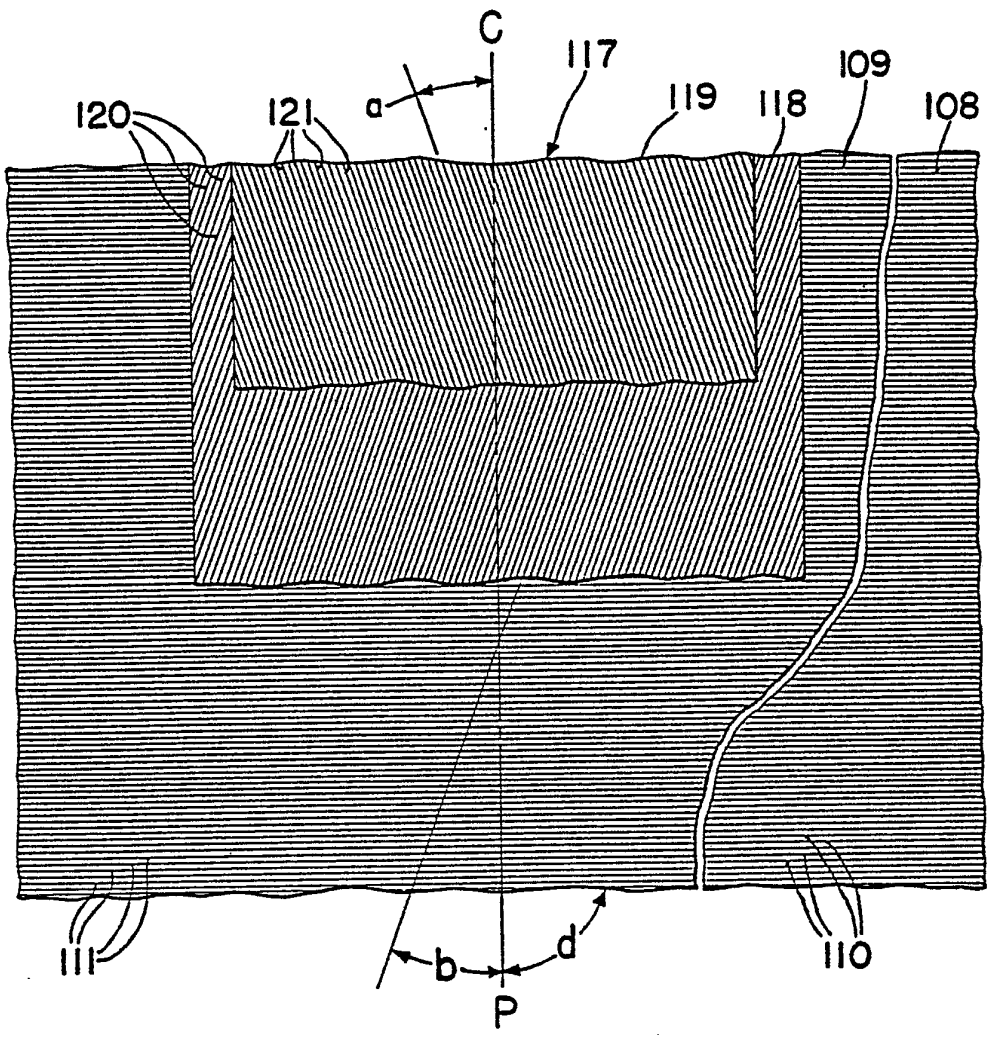

FIG. 9

5/5

FIG. 10

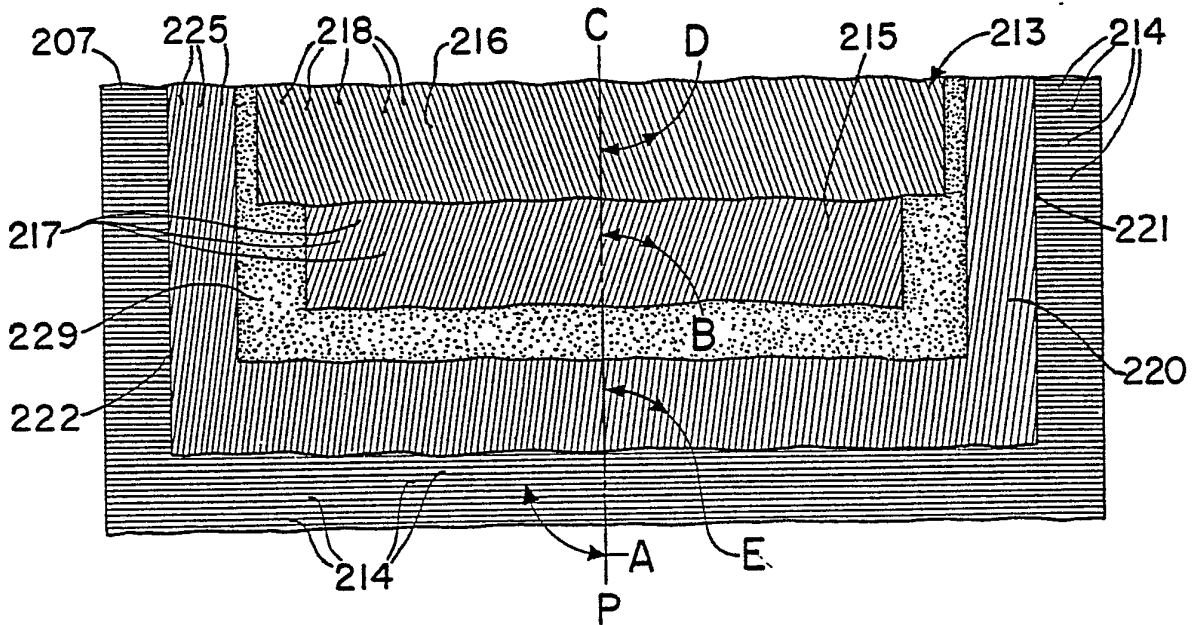
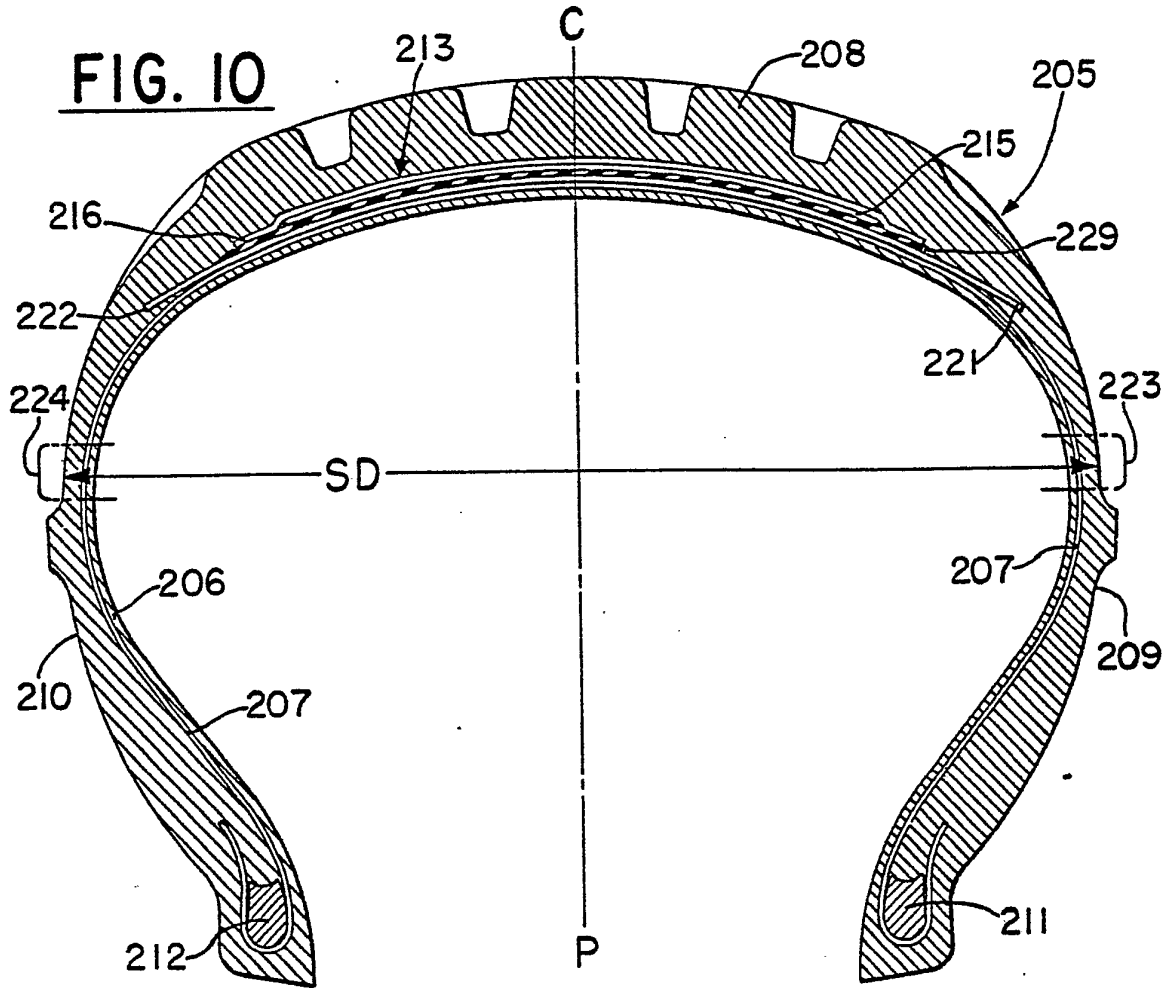

FIG. II



INTERNATIONAL SEARCH REPORT

Wo 80100069

International Application No PCT/US 79/00311

I. CLASSIFICATION OF SUBJECT MATTER (if several classification symbols apply, indicate all) ³		
According to International Patent Classification (IPC) or to both National Classification and IPC		
INTL. CL. B60C 9/10 U.S. Cl. 152/354 57/139		
II. FIELDS SEARCHED		
Minimum Documentation Searched ⁴		
Classification System	Classification Symbols	
U.S.	152/354, 356R, 359 57/139 156/123, 127, 128	
Documentation Searched other than Minimum Documentation to the Extent that such Documents are Included in the Fields Searched ⁵		
III. DOCUMENTS CONSIDERED TO BE RELEVANT ¹⁴		
Category ⁶	Citation of Document, ¹⁶ with indication, where appropriate, of the relevant passages ¹⁷	Relevant to Claim No. ¹⁸
X	US, A, 3756883, Published 4, September 1973, Gay	1-21
X	US, A, 3929180, Published 30, December 1975, Kawase et al	1-21
A	US, A, 3486546, Published 30, December 1969, Sidles et al	1, 5, 8, 9, 13, 17, 18
<p>⁹ Special categories of cited documents: ¹⁵</p> <p>"A" document defining the general state of the art</p> <p>"E" earlier document but published on or after the international filing date</p> <p>"L" document cited for special reason other than those referred to in the other categories</p> <p>"O" document referring to an oral disclosure, use, exhibition or other means</p> <p>"P" document published prior to the international filing date but on or after the priority date claimed</p> <p>"T" later document published on or after the international filing date or priority date and not in conflict with the application, but cited to understand the principle or theory underlying the invention</p> <p>"X" document of particular relevance</p>		
IV. CERTIFICATION		
Date of the Actual Completion of the International Search ²	Date of Mailing of this International Search Report ²	
28, August 1979	19 SEP 1979	
International Searching Authority ¹	Signature of Authorized Officer ²⁰	
ISA/US	Gene A. Church 8/30/79 GENE A. CHURCH	