



## INTERNATIONAL APPLICATION PUBLISHED UNDER THE PATENT COOPERATION TREATY (PCT)

<p>(51) International Patent Classification <sup>6</sup> : <b>G06K 11/08</b></p>	<p><b>A1</b></p>	<p>(11) International Publication Number: <b>WO 96/32693</b> (43) International Publication Date: 17 October 1996 (17.10.96)</p>
<p>(21) International Application Number: PCT/IB96/00326 (22) International Filing Date: 12 April 1996 (12.04.96) (30) Priority Data: 9507761.6 13 April 1995 (13.04.95) GB (71) Applicant (for all designated States except US): MOTOROLA INC. [US/US]; 1303 Algonquin Road, Schaumburg, IL 60196 (US). (72) Inventors; and (75) Inventors/Applicants (for US only): GEVA, Amir [IL/IL]; 8 Hatamar Street, 50200 Beit Dagan (IL). ROSENHEIMER, Amir [IL/IL]; 29 Ben Yhuda Street, Petach Tikva 49373 (IL). (74) Agents: RHYNE, Lesley, A. et al.; Motorola, European Intellectual Property Operations, Midpoint, Alencon Link, Basingstoke, Hampshire RG21 7PL (GB).</p>		<p>(81) Designated States: AM, AT, AU, BB, BG, BR, BY, CA, CH, CN, CZ, DE, DK, EE, ES, FI, GB, GE, HU, JP, KE, KG, KP, KR, KZ, LK, LR, LT, LU, LV, MD, MG, MN, MW, MX, NO, NZ, PL, PT, RO, RU, SD, SE, SI, SK, TJ, TT, UA, US, UZ, VN, ARIPO patent (KE, LS, MW, SD, SZ, UG), European patent (AT, BE, CH, DE, DK, ES, FI, FR, GB, GR, IE, IT, LU, MC, NL, PT, SE), OAPI patent (BF, BJ, CF, CG, CI, CM, GA, GN, ML, MR, NE, SN, TD, TG).</p> <p><b>Published</b> With international search report. Before the expiration of the time limit for amending the claims and to be republished in the event of the receipt of amendments.</p>

(54) Title: POSITION-DETERMINING INPUT DEVICE AND LIGHT EMITTING PEN

## (57) Abstract

A position-determining input device is described having a light emitting cursor device (10) and at least two light sensing elements (11 and 13) in a first linear array (12) extending in a first dimension, for providing signals responsive to light incident thereon. The position-determining input device further comprises a processing device (16) coupled to the at least two light sensing elements (11 and 13) for calculating the position of the light emitting cursor device (10) in the first dimension dependent on the signals from the at least two light sensing elements (11 and 13). A light pen is also described.

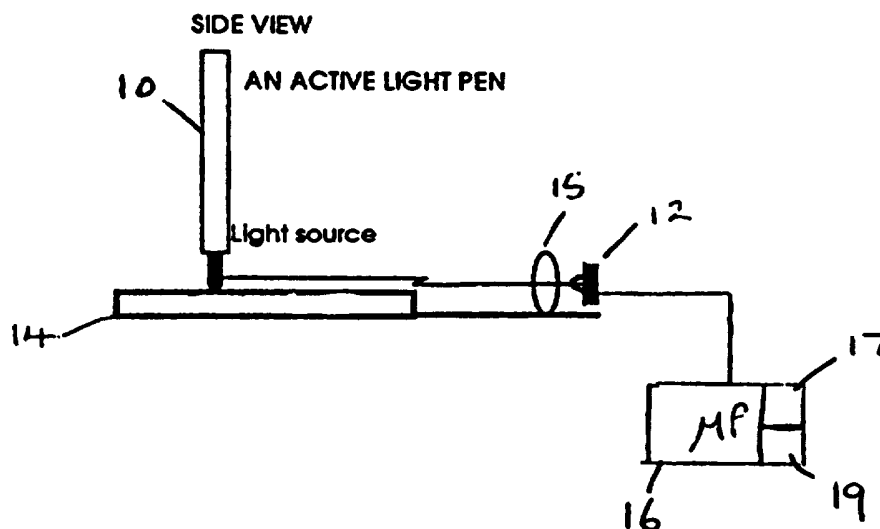

**FOR THE PURPOSES OF INFORMATION ONLY**

Codes used to identify States party to the PCT on the front pages of pamphlets publishing international applications under the PCT.

AM	Armenia	GB	United Kingdom	MW	Malawi
AT	Austria	GE	Georgia	MX	Mexico
AU	Australia	GN	Guinea	NE	Niger
BB	Barbados	GR	Greece	NL	Netherlands
BE	Belgium	HU	Hungary	NO	Norway
BF	Burkina Faso	IE	Ireland	NZ	New Zealand
BG	Bulgaria	IT	Italy	PL	Poland
BJ	Benin	JP	Japan	PT	Portugal
BR	Brazil	KE	Kenya	RO	Romania
BY	Belarus	KG	Kyrgyzstan	RU	Russian Federation
CA	Canada	KP	Democratic People's Republic of Korea	SD	Sudan
CF	Central African Republic	KR	Republic of Korea	SE	Sweden
CG	Congo	KZ	Kazakhstan	SG	Singapore
CH	Switzerland	LI	Liechtenstein	SI	Slovenia
CI	Côte d'Ivoire	LK	Sri Lanka	SK	Slovakia
CM	Cameroon	LR	Liberia	SN	Senegal
CN	China	LT	Lithuania	SZ	Swaziland
CS	Czechoslovakia	LU	Luxembourg	TD	Chad
CZ	Czech Republic	LV	Latvia	TG	Togo
DE	Germany	MC	Monaco	TJ	Tajikistan
DK	Denmark	MD	Republic of Moldova	TT	Trinidad and Tobago
EE	Estonia	MG	Madagascar	UA	Ukraine
ES	Spain	ML	Mali	UG	Uganda
FI	Finland	MN	Mongolia	US	United States of America
FR	France	MR	Mauritania	UZ	Uzbekistan
GA	Gabon			VN	Viet Nam

## POSITION-DETERMINING INPUT DEVICE AND LIGHT EMITTING PEN

### Field of the Invention

5

This invention relates to position-determining input devices. The invention is applicable to, but not limited to, use with digitizing technologies for pen-based computer systems. Separately and in addition it relates to a light emitting pen for such an input device.

10

### Background of the Invention

Three different digitizing technologies currently exist for determining the position of the pen in pen-based computer systems. The three technologies are resistive, electrostatic and electromagnetic. The digitizing technology must work effectively with a liquid crystal display (LCD) screen, it must protect the LCD polarized surface, and it should accurately simulate the sense of pen and paper.

15

Resistive digitizing technologies comprise a single or double layer of transparent conductive sheet applied over a protective glass surface and positioned above the top polarizing layer of the LCD screen. The double-layered version relies on membrane touch-panel technology as known to those skilled in the art. In operation, the pen causes the two sheets to make contact and the currents are measured to determine an 'x' and 'y' coordinate for the pen.

20

25

A disadvantage of the resistive digitizer technology is that the two conductive sheets reduce the brightness of the screen significantly and are typically influenced by temperature and humidity in such a way as to adversely affect the uniform resistivity of the conductive sheets. As a result the positional measurements of the pen are less accurate. A further problem associated with resistive digitizing technologies is that the measurements do not allow for proximity sensing of the pen. Hence, continuous depressions of the pen on the conductive sheets creates a limited life span for the sheets and further reduces the accuracy of the measurements over time.

30

35

Electrostatic (or capacitive) digitizers require a tethered pen. A transparent conductive layer must also be deposited on the underside of the protective glass shield. In this way, as the pen nears the surface of the glass, the electronic signal in the pen creates a capacitive effect with

the conductive sheet on the underside of the glass. Relative current measurements determine the 'x' and 'y' co-ordinate position of the pen.

The major disadvantages of using electrostatic digitizers are that they require tethered pens and that they reduce optical transmissions of the LCD screen by a similar level to the single-layer resistive technique.

Electromagnetic digitizers rely on a series of looped coils on a sensor board beneath the LCD screen. A magnetic field is created through the coils. The pen may either reflect these electromagnetic waves back to the sensor board by its own coil inside of the pen, or the pen is tethered and sends back its own signal. Pen position is determined by measuring the magnetic signal from the pen relative to the position of the sensor board coils under the LCD screen.

A disadvantage of the electromagnetic digitizer is that it requires the "light-pipe" design for back-lighting, as known to those skilled in the art. This method of back-lighting requires that the light source is positioned at the side of the LCD screen, rather than behind the screen. Additionally the electromagnetic digitizer requires a magnetic shield to be placed between the sensor board and the system motherboard.

This invention seeks to provide an improved alternative arrangement for determining the position of digitizer input elements such as computer pens.

### Summary of the Invention

According to the invention, a position-determining input device is provided comprising: a light emitting cursor device and at least two light sensing elements in a first linear array e.g. a CCD array or a photodiode array, extending in a first dimension, for providing signals responsive to light incident thereon. A processing device is also provided, coupled to the at least two light sensing elements, for calculating the position of the light emitting cursor device in the first dimension dependent on the signals from the at least two light sensing elements.

In this manner light emitted from the light emitting cursor device is incident upon the light sensing elements. The incident light is then converted to electrical signals which are sent to the processing device. The processing determines the position of the light emitting cursor device.

Advantageously, the position-determining input device is light, has low power consumption, is immune to noise and does not produce radio frequency interference (RFI) noise.

Preferably the position-determining input device further comprises a planar element having a first edge extending in the first dimension, wherein the at least two light sensing elements are disposed at the first edge of the planar element.

5 In this manner the position of the light emitting cursor device on the planar element is determined in at least the first dimension.

Advantageously, the position-determining input device does not require a specific, active board with in-built sensors for determining positions.

10 Preferably the planar element is either a beam splitter or has light conducting and light reflecting properties and the first linear array comprises a multiplicity of light sensing elements, each providing a signal to the processing device.

15 In this manner, light passing through or on the surface of the planar element, perpendicular to the first dimension, is incident on the multiplicity of light sensing elements. The processing device calculates the position of the light emitting cursor device in the first dimension substantially dependent on the position in the first dimension of the individual light sensing element on which incident light is most intense.

20 Advantageously, the multiplicity of light sensing elements provides a very high resolution of the position-determining input device.

25 Preferably, the processing device includes an intensity/distance computation function for computing a position for the light emitting cursor device in a second dimension, perpendicular to the first dimension, according to intensity of light incident on the first linear array in the first dimension. The position can be computed for the light emitting cursor device in a third dimension, perpendicular to the first dimension and to the second dimension, according to intensity of light incident on the first and second linear arrays in the first and second dimensions.

30 As a preferred feature, the position-determining input device further comprises at least two light sensing elements in a second linear array extending in a second dimension, for providing signals responsive to light incident thereon. Preferably each linear array comprises a multiplicity of light sensing elements, each providing a signal to the  
35 processing device, whereby the processing device calculates the position of the light emitting cursor device in the first and second dimensions substantially dependent on the positions in the first and second dimension of the respective individual light sensing elements in those arrays on which incident light is most intense.

As an optional feature, the position-determining input device further comprises at least two light sensing elements in a third linear array extending in a third dimension, for providing signals responsive to light incident thereon.

5 In this manner a three-dimensional position of the light emitting cursor device is determined.

In accordance with another aspect of the invention, a light pen is provided comprising a power source, a light emitting element, a push-to-make switch connecting the light emitting element to the power source,  
10 and an elongate housing surrounding the power source and the light emitting element, with the light emitting element protruding from an end of the housing and with the light emitting element being mechanically coupled to the push-to-make switch, whereby pressure on the light emitting element closes the switch and causes the light emitting element  
15 to emit light.

In this manner, a battery-efficient light pen is provided.

Preferred embodiments of the invention will now be described, by way of example only, with reference to the drawings.

## 20 Brief Description of the Drawings

FIG. 1 shows a side view of a position-determining input device in accordance with a first embodiment of the invention.

FIG. 2 shows an upper view of device of FIG. 1.

25 FIG. 3 is a graph of light intensity across one dimension of the position-determining input device of FIG. 1.

FIG. 4 shows a number of graphs of light intensity across one dimension of the position-determining input device of FIG. 1 with the different graphs related to the distance in a second dimension.

30 FIG. 5 shows a side view of an array of beam splitters in accordance with a second embodiment of the invention.

FIG. 6 shows an upper view of a two-dimensional plane using two light sensor arrays.

35 FIG. 7 is a three-dimensional graph showing how the light intensity measured in the two-dimensional plane of FIG. 6 is used to determine the position of a light emitting cursor device in a third dimension.

FIG. 8 is a three-dimensional view of a planar element comprising an array of beam splitters and two light sensor arrays in accordance with a third embodiment of the invention.

FIG. 9 is a three dimensional view of a planar element comprising a two-level array of beam splitters in accordance with a fourth embodiment of the invention.

FIG. 10 shows a three-dimensional view of a position-determining input device having three light sensor arrays positioned in the three-dimensions in accordance with an optional feature of the first four embodiments of the invention.

FIG. 11 is a cross section of a light pen in accordance with a further aspect of the invention.

10

### Detailed Description of the Drawings

Referring first to FIG. 1, a side view of a position-determining input device is shown. The position-determining input device comprises a light emitting cursor device 10, a planar element 14, and an optical lens 15 operably coupled to a light sensing element 12. The light sensing element 12 is a light sensor array, comprising at least two light sensing elements, and is disposed at a first edge of the planar element 14. A processing device 16 e.g. a microprocessor, comprises an intensity/distance computation function 17 and a memory element 19 and is operably coupled to the light sensor array 12.

In operation, the light emitting cursor device 10, e.g. an active light pen, emits a beam of light on to the planar element 14. The beam of light is reflected off the planar element 14 and along the surface of the planar element 14, through the optical lens 15 and onto the light sensor array 12. The light sensor array 12 may be a charge coupled device (CCD) array or a photodiode array. The light sensor array 12 transmits signals to the processing device 16, responsive to light incident on the light sensing elements 11 and 13 of the light sensor array 12. The intensity/distance computation function 17 of the processing device 16 calculates the position of the light emitting cursor device 10 in one dimension of the planar element 14 according to the transmitted signals from the light sensing elements. An optional feature of this embodiment of the invention is for the light emitting cursor device 10 to emit a beam of light only when the light emitting cursor device 10 touches the planar element 14, thereby reducing the diffraction of light from the light emitting cursor device 10 and improving the accuracy of the position-determining calculation of the processing device 16.

Referring now to FIG. 2, an upper view of a two-dimensional plane in accordance with the position-determining input device of FIG. 1 is shown. The planar element 14 is shown in 'x' and 'y' dimensions with the position in the 'y' dimension being monitored by the light sensing  
5 elements 11 and 13 of the light sensor array. The light sensor array 12 is operably coupled to the optical lens 15 and the processing device 16 and is disposed at a first edge of the planar element 14. The processing device 16 comprises an intensity/distance computation function 17 and a memory element 19.

10 In operation, the position of the 'y' dimension of the light emitting cursor device 10, of FIG. 1, is calculated from the beam-hit point on the light sensor array 12. In a preferred embodiment the light sensor array 12 comprises a multiplicity of light sensing elements, each transmitting a signal to the processing device 16. The intensity/distance computation  
15 function 17 of the processing device 16 calculates the position of the light emitting cursor device 10 in the first 'y' dimension substantially dependent on the position in the first 'y' dimension of the individual light sensing element on which incident light is most intense. The position of the 'x' dimension of the light emitting cursor device 10 of FIG. 1 is  
20 calculated using the graph of FIG. 3.

Referring now to FIG. 3, a graph is shown of light intensity versus distance along a first dimension e.g. the 'y' dimension, of the planar element 14, in accordance with the position-determining input device of FIG. 1. The light emitting cursor device 10, of FIG. 1, emits light onto the  
25 light sensor array 12. The processing device 16 produces a curve 18 of light intensity along the 'y' dimension of the planar element 14 from the signals transmitted from the light sensing elements of the light sensor array 12. The 'y<sub>0</sub>' position 20 of the emitted light from the light emitting cursor device 10 is calculated from the point of the maximum intensity of  
30 light (y<sub>0</sub>) measured by the light sensing elements.

Referring now to FIG. 4, a number of graphs of light intensity across one-dimension of the planar element 14 are shown, in accordance with the position-determining input device of FIG. 1. The level of intensity of the light emitting cursor device 10 of FIG. 1, measured by the  
35 light sensing elements, varies in the 'x' dimension between a minimum 'x' value and a maximum 'x' value. The light sensor array 12 transmits a signal to the processing device 16, dependent upon the intensity of light incident to the light sensing elements, of FIG. 1 or FIG. 2. At a known 'y' position, e.g. the 'y<sub>0</sub>' position 20 of the maximum intensity of light, a



calculation is performed to determine the 'x' position of the light on the planar element 14, from the light intensity versus distance graphs of FIG. 4. The intensity of light corresponding to the  $y_0$  position is measured as  $I_0$  22. With the position of  $y_0$  20 and  $I_0$  22 known, the 'x' position ( $x_0$ ) 24 of the light emitting cursor device 10, is determined from the graphs of FIG. 4.

A preferred option for determining the 'x' position for the light intensity measured by the light sensing elements, is, at the processing device 16, interpolating between the level of light intensity measured to the level of light intensity known for the maximum 'x' and minimum 'x' positions. In a preferred embodiment of the invention the curves associated with different positions of the light emitting cursor device 10 in the 'x' dimension are stored in, and retrieved from, a memory element 19 in the processing device 16.

For the graphs of FIG. 4 to provide an accurate indication of the 'x' position of the light emitting cursor device 10, of FIG. 1, the light emitting cursor device 10 touches the planar element 14 when emitting the light beam.

In this manner, the effect of a third-dimension of the light emitting cursor device 10, adversely affecting the accuracy of the intensity ('x'-position) curves, is removed.

The position-determining calculation occurs in the intensity/distance computation function 17 of the processing device 16. The intensity/distance computation function 17 calculates the position of the light emitting cursor device 10 in the second 'x' dimension, perpendicular to the first 'y' dimension, according to intensity of light incident on the first linear array (light sensor array 12) in the first dimension. Advantageously, only one light sensor array 12, positioned in one dimension, is used to determine the two-dimensional position of the light source. Preferably the light sensor array 12 comprises a multiplicity of light sensing elements, e.g. 20 to 1000 in number.

If the light emitting cursor device 10 does not touch the planar element 14, when emitting a light beam, the graph of FIG. 4 provides an indication of the position in a third, 'z', dimension of the light emitting cursor device 10 of FIG. 1. The shape of the curves of FIG. 4 are consequently more constant (less light-intensity varying) for the case where the light emitting cursor device 10 is positioned above the planar element 14. In this situation the light is dispersed more evenly between the light sensing elements 11 and 13, of the light sensor array 12, as

compared to the situation where the light emitting cursor device 10 touches the planar element 14. When the light emitting cursor device 10 touches the planar element 14 and emits a beam of light, the light will be less dispersed between the light sensing elements 11 and 13 and the graphs of FIG. 4 have more pronounced peaks of light intensity levels.

Referring now to FIG. 5, a side view of a beam splitter planar element 26 is shown in accordance with a preferred embodiment of the invention. The beam splitter planar element 26 in FIG. 5 replaces the planar element 14 of FIG. 1. The beam splitter planar element 26 comprises a number of parallel mirrors (beam splitters) positioned at 45 degrees to the surface of the beam splitter planar element 26.

In operation the light emitting cursor device 10 emits a light beam into the beam splitter planar element 26. The emitted light is reflected off one of the mirrors of the beam splitter array, and through, the array of beam splitters to the optical lens 15 and the light sensor array 12. Preferably the light sensor array 12 comprises a multiplicity of light sensing elements. Each light sensing element of the light sensor array 12 transmits signals to the processing device 16. The intensity/distance computation function 17 in the processing device 16 determines a position of the light emitting cursor device 10, in a first dimension by calculating which light sensing element received the highest intensity of light from the light emitting cursor device 10. The intensity/distance computation function 17 in the processing device 16 also calculates the position of the light emitting cursor device 10 in a second dimension by measuring the intensity of light that has been reflected through the beam splitter planar element 26. The intensity of light is attenuated by each mirror in the beam splitter planar element 26. In this manner the intensity of light measured at the light sensor array relates to a given position of the light emitting cursor device 10 in the second dimension. The resolution of the measurement of the 'x' position is determined by the finite width between the mirrors of the beam splitter planar element 26.

Referring now to FIG. 6 an upper view of a two-dimensional position-determining input device is shown, in accordance with a preferred embodiment of the invention. The position-determining input device comprises a planar element 14 and two light sensor arrays 12 and 28. The light sensor arrays 12 and 28 preferably comprise a multiplicity of light sensing elements and are disposed at first and second edges of the planar element 14. By way of a simplified explanation they are shown in FIG. 6 as comprising two light sensing elements 11 and 13, and 31 and 33

respectively. The two light sensor arrays 12 and 28 are respectively coupled to optical lenses 15 and 32 through band-pass optical filters 34 and 36 which are arranged to select only the desired light source. The light sensor arrays 12 and 28 are operably coupled to a processing device 5 16, for processing signals from the light sensor arrays 12 and 28. The processing device 16 comprises an intensity/distance computation function 17 and a memory element 19.

The light sensor arrays 12 and 28 are positioned for operation in two-dimensions of the planar element 14 and are extensions of the light 10 sensor array (light sensing element) 12 described for primary operation in one dimension of FIG. 1, FIG. 2 or FIG. 5. The light sensor arrays 12 and 28 are positioned in a first and second dimension of the planar element 14 and indicate the 'x' and 'y' positions of the light emitting cursor device 10. Each light sensing element 11, 13, 31 and 33 within the light sensor 15 arrays 12 and 28 provides signals responsive to light incident thereon. Signals from each light sensing element in the light sensor arrays 12 and 28 are transmitted to the processing device 16. The intensity/distance computation function 17 of the processing device 16 determines which 20 light sensing elements receive the highest intensity of incident light incident and thereby the two-dimensional position of the light emitting cursor device 10. Preferably the light sensor arrays 12 and 28 comprise a multiplicity of light sensing elements.

In an optional feature of the preferred embodiment of the invention, the position-determining operation in two dimensions, described 25 previously, is used for calculating the position of the light emitting cursor device 10 in a third, 'z', dimension. The third 'z' dimension is perpendicular to the first 'x' dimension and to the second 'y' dimension. The intensity/distance computation function 17 of the processing device 16 calculates the position of the light emitting cursor device 10 according to 30 the intensity of light incident on the first and second light sensor arrays 28 and 30 as shown in FIG. 7.

The light sensor arrays 12 and 28 may be a CCD array or a photodiode array. The planar element 14 may be an array of beam splitters or have light conducting and light reflecting properties.

35 Referring now to FIG. 7, a three-dimensional graph is shown. The 'x<sub>0</sub>' and 'y<sub>0</sub>' positions of the graph are determined substantially as described with reference to the position-determining input device of FIG. 6. However, the intensity of light from the light emitting cursor device 10,

as shown in FIG. 7, is measured by the two light sensor arrays 12 and 28 of FIG. 6.

In operation the light intensity measured by the intensity/distance computation function 17 in the two-dimensional plane of FIG. 6 is used to  
5 determine the position of the light emitting cursor device 10 in the third, 'z' dimension.

A further optional feature for determining the position of the light emitting cursor device 10 in a third 'z' dimension is to use the first light sensor array 12 substantially as described with reference to FIG. 2, FIG. 3  
10 and FIG. 4, to determine the 'x' and 'y' positions of the light emitting cursor device 10. The second light sensor array 28 is then arranged in the third dimension to determine the 'z' position of the light emitting cursor device 10.

Referring now to FIG. 8 a three-dimensional view of an optional  
15 feature of the position-determining input device of FIG. 6 is shown. The planar element 14 is replaced by a beam splitter planar element 26. The position-determining input device comprises a beam splitter planar element 26 and two light sensor arrays 12 and 28, each having at least two light sensing elements disposed at a first and second edge of the beam  
20 splitter planar element 26. The two light sensor arrays 12 and 28 are respectively operably coupled to optical lenses 15 and 32 through band-pass optical filters 34 and 36, arranged to select only the desired light source. The light sensor arrays 12 and 28 are operably coupled to a processing device 16, for processing the signals from the light sensor  
25 arrays 12 and 28. The processing device 16 comprises an intensity/distance computation function 17 and a memory element 19.

In operation the light sensor arrays 28 and 30 provide an indication of the 'x' and 'y' position of the light emitting cursor device 10. The light sensor array 12, receives light emitted along the top surface of the beam  
30 splitter planar element 26 to indicate the 'x' position of the light emitting cursor device 10. The light sensor array 28, receives light reflected by the beam splitter mirrors and transmitted through the beam splitter planar element 26 to indicate the 'y' position of the light emitting cursor device 10.

35 An alternative arrangement using a two-level beam splitter planar element is shown in FIG. 9. In operation, light is emitted from the light emitting cursor device 10 into the two level beam splitter planar element. A first portion of light is reflected off beam splitter mirrors in a first array of beam splitters contained within a first beam splitter planar element 38,

and transmitted through the beam splitter planar element 38, to indicate the 'x' position of the light emitting cursor device 10. A second portion of the light is emitted through the first beam splitter planar element 38 into a second beam splitter planar element 26, where the beam splitter  
5 mirrors are arranged orthogonally to the beam splitter mirrors of the first beam splitter planar element 38. The light is reflected off the beam splitter mirrors in the second beam splitter planar element 26, and transmitted through the beam splitter planar element 26, to indicate of the 'y' position of the light emitting cursor device 10.

10 The preferred embodiment of the invention comprises two light sensing elements, but an optional feature would be to include a third light sensing element to measure the position of the light emitting cursor device 10 in a third dimension, as shown in FIG. 10.

Referring now to FIG. 10 a three-dimensional view of a planar  
15 element 14 with three light sensor arrays 12, 28 and 30 is shown in accordance with an optional feature of the preferred embodiment of the invention. Two of the three light sensor arrays, 12 and 28, are disposed at a first and second edge of the planar element 14. The three light sensor arrays 12, 28 and 30 are operably coupled to optical lenses 15, 32 and 42  
20 and band-pass optical filters 34, 36 and 40 which are arranged to select only the desired light source. The light sensor arrays 12, 28 and 30 are also operably coupled to a processing device 16, for processing the signals from light sensing elements in the light sensor arrays 12, 28 and 30. The processing device 16 comprises an intensity/distance computation function  
25 17 and a memory element 19.

In operation the position of the light emitting cursor device 10 in a third dimension is determined, by the intensity/distance computation function 17 of the processing device 16, from signals responsive to light incident on the light sensing elements in the light sensor arrays 12, 28  
30 and 30. The light sensor arrays 12, 28 and 30 are any combination of linear light sensor arrays such as CCD arrays or photodiode arrays and are positioned in the 'x', 'y' and 'z' dimensions of the planar element 14. The planar element 14 may be a beam splitter planar element or have light reflecting and light conducting properties.

35 Advantageously the position-determining input device according to the preferred embodiment of the invention requires lower power consumption than present position-determining input devices. The position-determining input device according to the preferred embodiment of the invention is lighter, immune to noise, does not produce RFI and is

accurate. The resolution of the position-determining calculations is dictated by the number of light sensing elements and the planar element used and not to the variable performance associated with a resistive touch sensor pad. The planar element is not active (i.e. does not require a current source to operate) and no calibration is required. A number of preferred embodiments have been provided that allow proximity sensing of the pen and a "tethered" pen is not needed.

Thus an alternative position-determining input device is described with improved performance over present devices.

Referring now to FIG. 11, a light pen is shown which is suitable for use in the two-dimensional input devices described above. The pen comprises a battery power source 100, a light emitting element 101, a push-to-make switch having contacts 102 and 103 and a mechanical spring 104. The light emitting element 101 is connected to the battery 100 via the contacts 103, 104 when the contacts are closed. The contacts are closed by pressing the pen on a surface such as planar element 14, causing spring 104 to compress and close the contacts 102, 103.

The arrangement has the advantage of power saving, because a convenient switch arrangement is provided causing power to be drawn only when there is downward pressure on the pen. Additionally, spurious inputs are avoided which might otherwise arise if a constant light source were used causing inputs to the input device when the pen is not in contact with the planar surface.

The combination of the light pen and a two-dimensional input device as described and claimed is a very advantageous combination.

Claims

1. A position-determining input device comprising:  
a light emitting cursor device;  
5 at least two light sensing elements in a first linear array extending in a first dimension, for providing signals responsive to light incident thereon; and,  
a processing device coupled to the at least two light sensing  
elements for calculating a position of the light emitting cursor device in  
10 the first dimension dependent on the signals from the at least two light sensing elements.
2. A position-determining input device according to claim 1, further comprising a planar element having a first edge extending in the first  
15 dimension, wherein the at least two light sensing elements are disposed at the first edge of the planar element
3. A position-determining input device according to claim 1, wherein  
20 the first linear array comprises a multiplicity of light sensing elements, each providing a signal to the processing device, whereby the processing device calculates the position of the light emitting cursor device in the first dimension substantially dependent on the position in the first dimension of the individual light sensing element on which incident light is most intense.  
25
4. A position-determining input device according to claim 3, wherein  
the processing device includes an intensity/distance computation function for computing at least a position for the light emitting cursor device in a  
second dimension, perpendicular to the first dimension, according to  
30 intensity of light incident on the first linear array in the first dimension.
5. A position-determining input device according to claims 3 or 4,  
wherein the first linear array is a CCD array.
- 35 6. A position-determining input device according to claim 3 or 4,  
wherein the first linear array is a photodiode array.

7. A position-determining input device according to any one of claims 2 to 6, wherein the planar element has light conducting and light reflecting properties.
- 5 8. A position-determining input device according claim 7, wherein the planar element is a beam splitter.
9. A position-determining input device according to claim 1, further comprising at least two light sensing elements in a second linear array  
10 extending in a second dimension, for providing signals responsive to light incident thereon.
10. A position-determining input device according to claim 9, further comprising a planar element having light conducting and light reflecting  
15 properties and having a first edge extending in the first dimension and a second edge extending in the second dimension, wherein the at least two light sensing elements of the first linear array are disposed at the first edge of the planar element and the at least two light sensing elements of the second linear array are disposed at the second edge of the planar  
20 element.
11. A position-determining input device according to claim 9, wherein each linear array comprises a multiplicity of light sensing elements, each providing a signal to the processing device, whereby the processing device  
25 calculates the position of the light emitting cursor device in first and second dimensions substantially dependent upon positions in the first and second dimensions of the respective individual light sensing elements in those linear arrays on which incident light is most intense.
- 30 12. A position-determining input device according to claim 9, 10 or 11, wherein each linear array is a CCD array.
13. A position-determining input device according to claim 9, 10 or 11, wherein each linear array is a photodiode array.  
35
14. A position-determining input device according to any one of claims 9 to 13, wherein the planar element has light conducting and light reflecting properties.



15. A position-determining input device according claim 14, wherein the planar element is a beam splitter.

5 16. A position-determining input device according to any one of claims 9 to 15, wherein the processing device includes an intensity/distance computation function for computing a position for the light emitting cursor device in a third dimension, perpendicular to the first dimension and to the second dimension, according to intensity of light incident on the first and second linear arrays in the first and second dimensions.

10

17. A position-determining input device according to any one of claims 9 to 15, further comprising at least two light sensing elements in a third linear array extending in a third dimension, for providing signals responsive to light incident thereon.

15

18. A light pen comprising a power source, a light emitting element, a push-to-make switch connecting the light emitting element to the power source, and an elongate housing surrounding the power source and the light emitting element, with the light emitting element protruding from an end of the housing and with the light emitting element being mechanically coupled to the push-to-make switch, whereby pressure on the light emitting element closes the switch and causes the light emitting element to emit light.

20

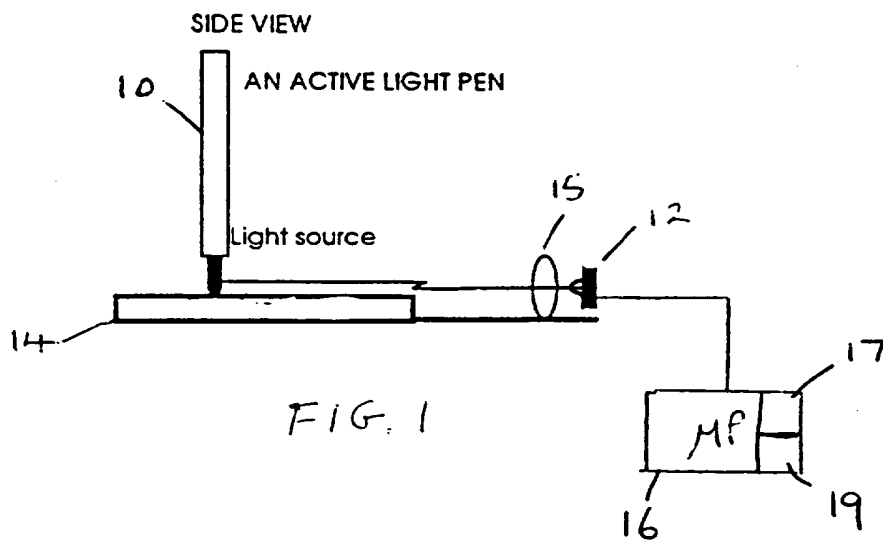
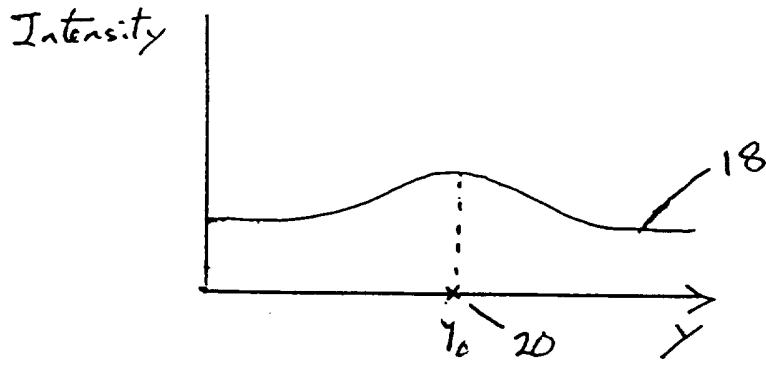
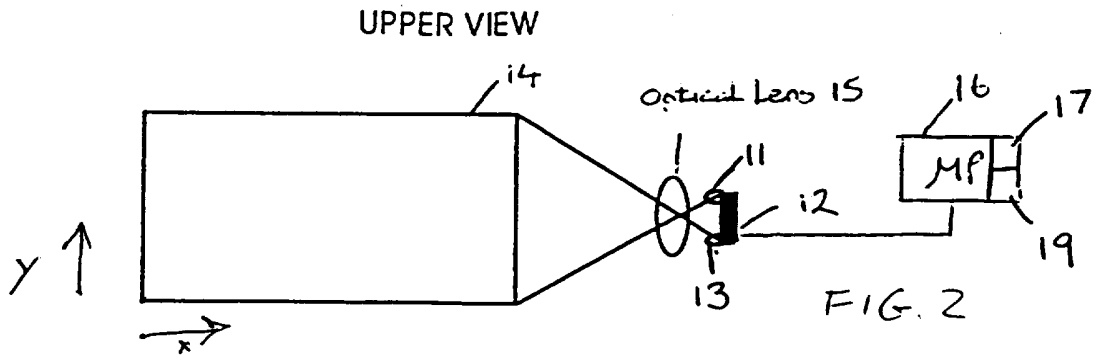

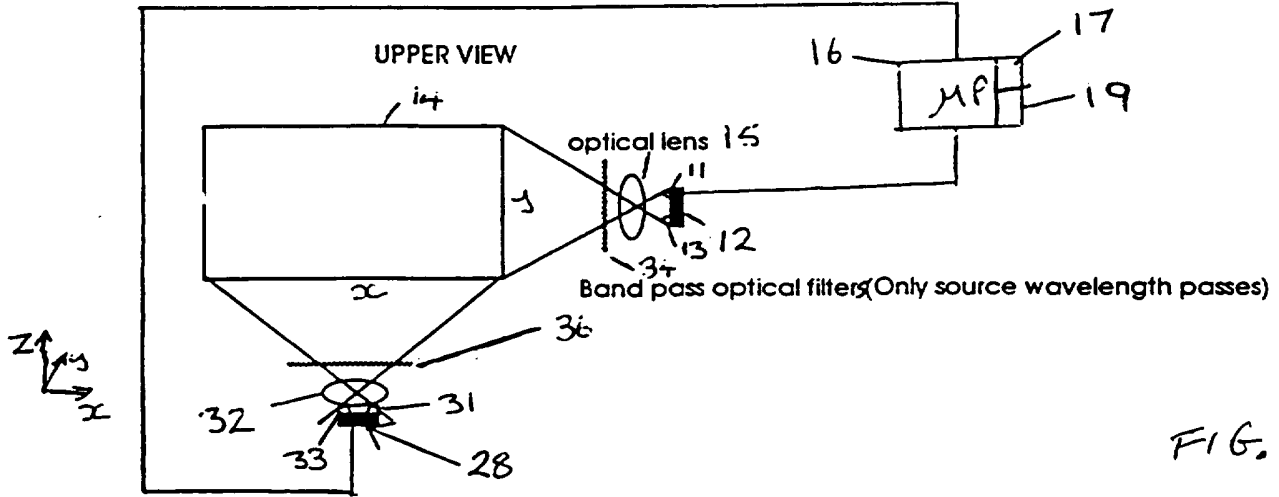

FIG. 6

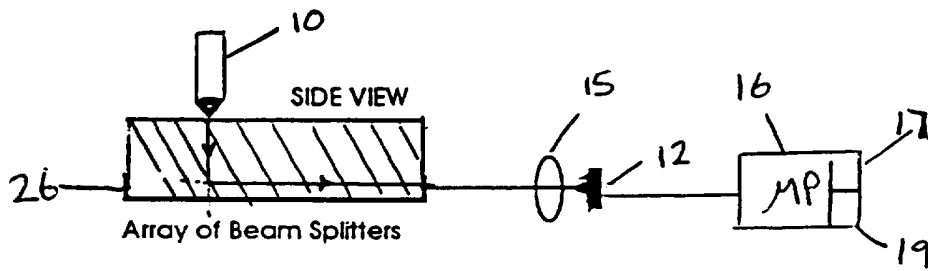

FIG. 5

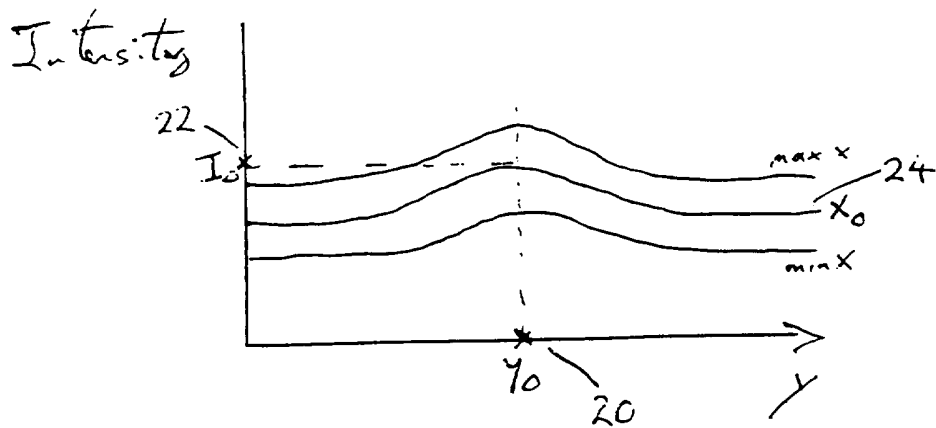

FIG. 4

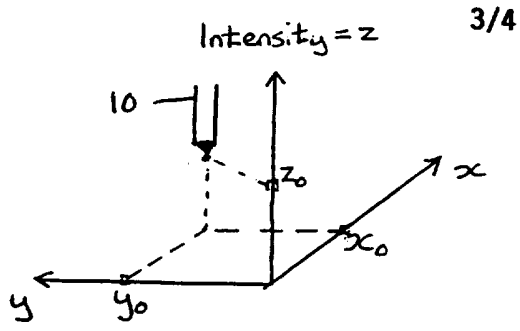

FIG. 7

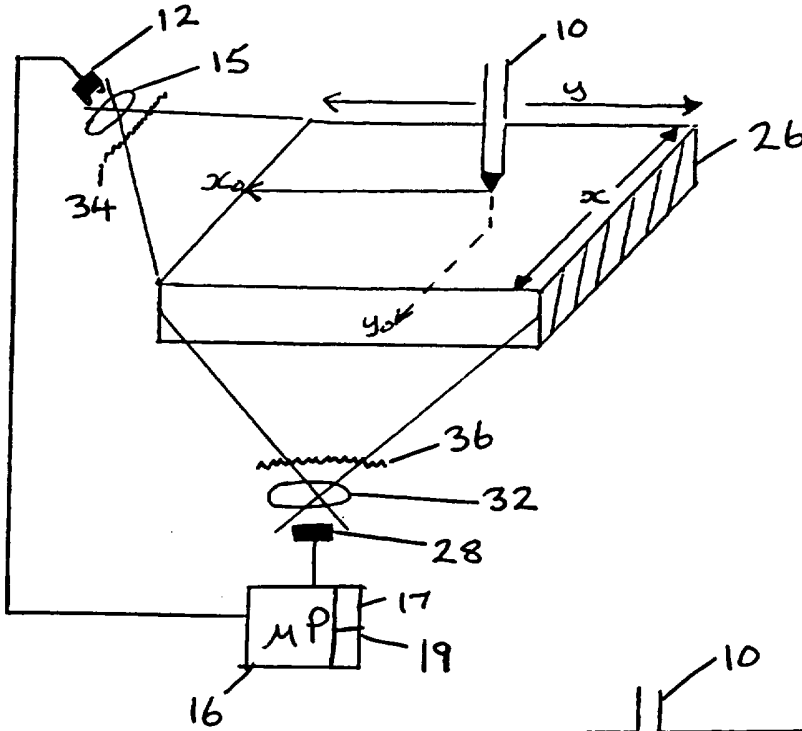

FIG. 8

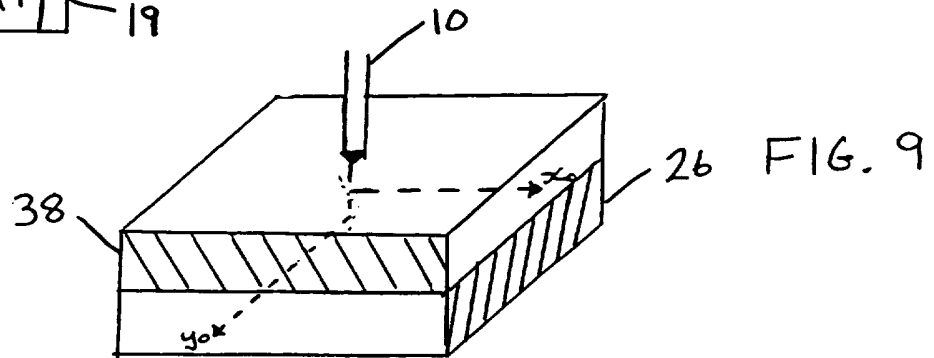

FIG. 9

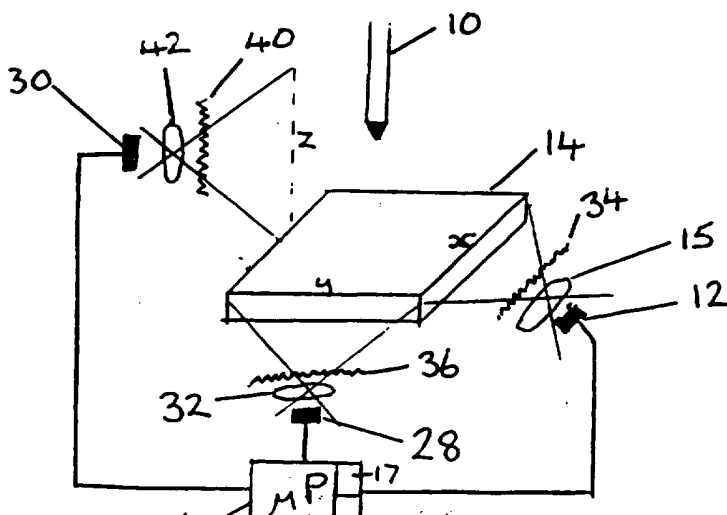

FIG. 10

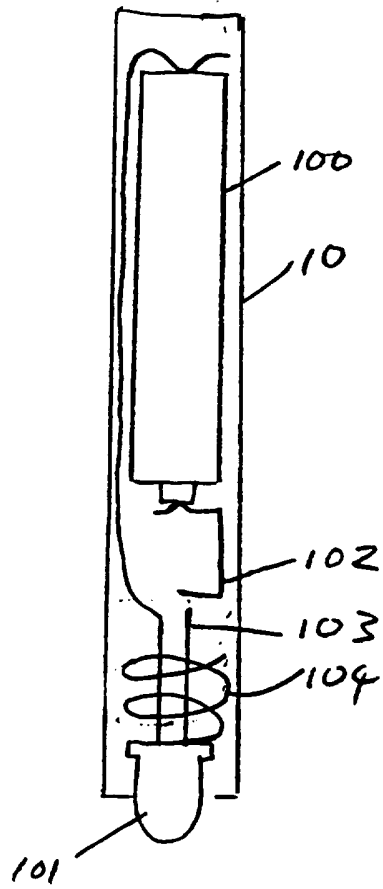

FIG. 11

# INTERNATIONAL SEARCH REPORT

Inter national Application No  
PCT/IB 96/00326

A. CLASSIFICATION OF SUBJECT MATTER  
IPC 6 G06K11/08

According to International Patent Classification (IPC) or to both national classification and IPC

**B. FIELDS SEARCHED**

Minimum documentation searched (classification system followed by classification symbols)  
IPC 6 G06K

Documentation searched other than minimum documentation to the extent that such documents are included in the fields searched

Electronic data base consulted during the international search (name of data base and, where practical, search terms used)

**C. DOCUMENTS CONSIDERED TO BE RELEVANT**

Category *	Citation of document, with indication, where appropriate, of the relevant passages	Relevant to claim No.
X	US,A,4 911 527 (GARCIA JR FELIX ET AL) 27 March 1990  see column 2, line 10 - line 55 see column 3, line 27 - line 45 see column 3, line 55 - line 64 see column 4, line 42 - line 48; figures 1-5  ---	1-7, 9-14,16, 17
X	US,A,4 320 292 (OIKAWA SHIGERU ET AL) 16 March 1982 see column 3, line 19 - line 64; figures 1,2  ---	1-15
X	US,A,5 164 585 (LIEU YIN S) 17 November 1992 see the whole document  ---	1-5,7, 9-12,14
-/--		

Further documents are listed in the continuation of box C.

Patent family members are listed in annex.

\* Special categories of cited documents :

- \*A\* document defining the general state of the art which is not considered to be of particular relevance
- \*E\* earlier document but published on or after the international filing date
- \*L\* document which may throw doubts on priority claim(s) or which is cited to establish the publication date of another citation or other special reason (as specified)
- \*O\* document referring to an oral disclosure, use, exhibition or other means
- \*P\* document published prior to the international filing date but later than the priority date claimed

- \*T\* later document published after the international filing date or priority date and not in conflict with the application but cited to understand the principle or theory underlying the invention
- \*X\* document of particular relevance; the claimed invention cannot be considered novel or cannot be considered to involve an inventive step when the document is taken alone
- \*Y\* document of particular relevance; the claimed invention cannot be considered to involve an inventive step when the document is combined with one or more other such documents, such combination being obvious to a person skilled in the art.
- \*&\* document member of the same patent family

Date of the actual completion of the international search

14 August 1996

Date of mailing of the international search report

05. 09. 96

Name and mailing address of the ISA

European Patent Office, P.B. 5818 Patentlaan 2  
 NL - 2280 HV Rijswijk  
 Tel. (+ 31-70) 340-2040, Tx. 31 651 epo nl,  
 Fax: (+ 31-70) 340-3016

Authorized officer

Nygren, P

# INTERNATIONAL SEARCH REPORT

International Application No  
PCT/IB 96/00326

**C.(Continuation) DOCUMENTS CONSIDERED TO BE RELEVANT**

Category *	Citation of document, with indication, where appropriate, of the relevant passages	Relevant to claim No.
X	US,A,5 227 622 (SUZUKI TORU) 13 July 1993 see column 3, line 1 - line 29; figures 3,4 <p style="text-align: center;">---</p>	1-5,18
X	EP,A,0 202 468 (LAITRAM CORP) 26 November 1986 see page 6, line 1 - line 14 see page 11, line 20 - page 12, line 20; figures 1,2,15 <p style="text-align: center;">-----</p>	1-4,6

# INTERNATIONAL SEARCH REPORT

Information on patent family members

International Application No

PCT/IB 96/00326

Patent document cited in search report	Publication date	Patent family member(s)	Publication date
US-A-4911527	27-03-90	NONE	
-----			
US-A-4320292	16-03-82	NONE	
-----			
US-A-5164585	17-11-92	NONE	
-----			
US-A-5227622	13-07-93	CA-A- 2060564	04-08-93
		DE-A- 4203591	12-08-93
		FR-A- 2687233	13-08-93
		GB-A,B 2264016	11-08-93
-----			
EP-A-0202468	26-11-86	US-A- 4688933	25-08-87
		CA-A- 1257917	25-07-89
		DE-A- 3684722	14-05-92
		JP-A- 61260322	18-11-86
		NO-B- 177167	18-04-95
-----			