

(No Model.)

C. M. FAIRBANKS.
MACHINE FOR CUTTING FILES.

No. 334,115.

Patented Jan. 12, 1886.

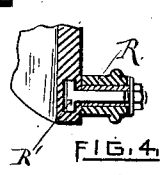
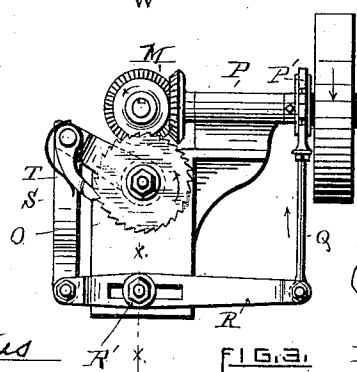
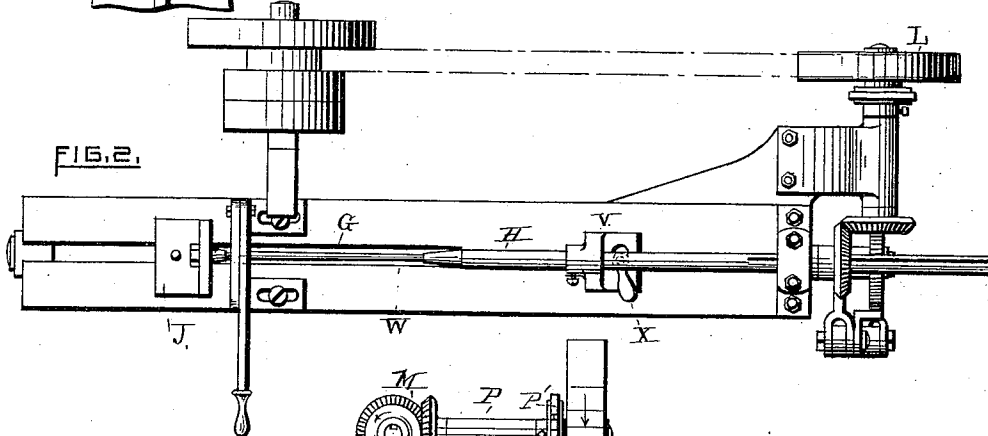
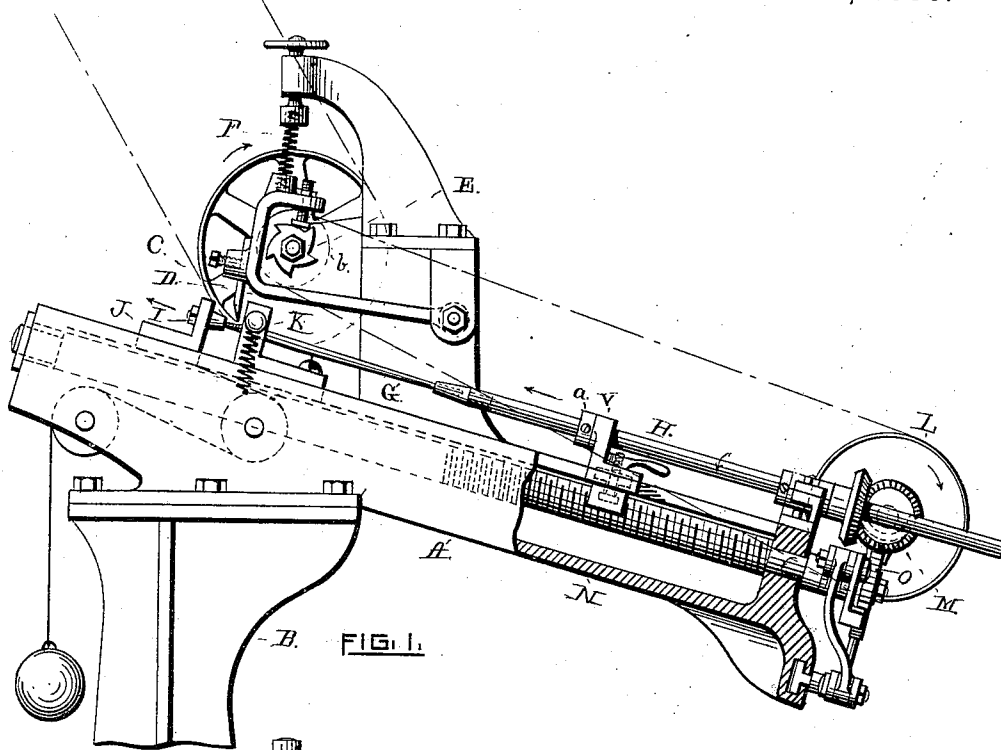

WITNESSES.

Charles H. Titus

James D. O'Brien

INVENTOR.

Crawford M. Fairbanks
By Walter B. Vincent Atty.

UNITED STATES PATENT OFFICE,

CRAWFORD M. FAIRBANKS, OF LINCOLN, RHODE ISLAND.

MACHINE FOR CUTTING FILES.

SPECIFICATION forming part of Letters Patent No. 334,115, dated January 12, 1886.

Application filed May 7, 1885. Serial No. 164,650. (No model.)

To all whom it may concern:

Be it known that I, CRAWFORD M. FAIRBANKS, of Lincoln, in the county of Providence and State of Rhode Island, have made certain

5 new and useful improvements in Machines for Cutting Files; and I do hereby declare that the following specification, taken in connection with the drawings making a part of the same, is a full, clear, and exact description thereof.

10 Figure 1 is an elevation, partly in section, of my improved file-machine. Fig. 2 is a top view of same with cutting mechanism removed. Fig. 3 is an end view of same. Fig. 4 is a section on line *x x*.

15 My invention relates to the cutting of round files, and has for its object the production of a machine by which the number of rows of teeth, as well as the number of teeth to the inch, may be varied and the same cut spirally or straight, as may be desired; and it consists in the mechanism hereinafter described.

20 In the machines for cutting round files heretofore in use both the feeding and turning of the blank are accomplished by one mechanism so constructed and operating that a relatively uniform rapidity of movement must result, which relation of movement cannot be changed or disturbed by any change or adjustment of the machine itself. It is necessary in cutting

25 such files to vary the number and direction of the rows of teeth, as well as the number of teeth to the inch, according to the particular service required of the file; and for this purpose it is desirable that the feeding and turning mechanisms should be capable of independent adjustment, and the relative speed of the two changed as occasion may require.

30 In my invention, which I will now proceed to describe, I so construct the feeding and turning mechanisms that the relative operation of the same may be changed to produce either of the desirable results above described.

35 In the drawings, A is the frame, which is supported by a perpendicular post or pillar, B. C is the cutting-tool, which is secured to an arm, D, pivoted at one end to the frame. The arm D is operated by a cam, E, and spring F, and its movement causes the tool to strike and cut the file-blank.

40 G is the file-blank, one end of which is held in a socket in the end of the arbor H and the

other in the socket I of the slide J, the blank passing over and being supported by a cutting-bed, K. The slide J is weighted so as to be held in contact with the file-blank. The arbor H, and with it the file-blank G, is rotated by the pulley L through the miter-gears M.

55 N is a screw extending lengthwise of the machine, and is rotated by a ratchet, O, operated by a cam, P', upon the shaft P, through the levers Q R S and pawl T.

60 V is a block which slides in a longitudinal slot, W. The under side of the block V is concave and provided with a screw-thread, and rests upon and engages the screw N, when thrown into contact by means of the cam-lever X. The arbor H passes through the upper or perpendicular portion of the block V, within which it has a free rotary movement.

65 *a* is a fixed collar upon the arbor H.

70 The arbor H may be moved longitudinally to adjust it to the length of the blank independent of the miter-gear, the latter being attached by means of a spline.

75 Having now described the several parts of the entire machine, I will now proceed to describe the operation of the rotating and feeding mechanism to which my invention more particularly relates. Commencing with the parts in the position shown in Figs. 1 and 2, the file-blank G having been adjusted in position, the machine is started, a rotary movement being communicated to the pulley L, which, through the miter-gears M, rotates the arbor H and the file-blank G, the latter as it rotates receiving the action of the tool C. At the same time the rotation of the pulley L operates the ratchet O, through the cam upon the shaft P, and the devices before described in connection therewith, and rotates the screw N. The rotation of the screw N moves forward the block V, the concave threaded surface of which is forced to engage with the screw, as described. As the block V is moved forward, it comes in contact with the fixed collar *a*, and carries forward the arbor H and feeds the blank G at the same time that it is rotated by the other devices before described. When the file has passed under the cutting-tool and been cut, the blank V is released by the proper movement of the lever X from its contact with the

80
85
90
95
100

screw N, whereupon the arbor H may be pushed back, another blank inserted, and the operation described repeated.

To vary the feed motion I may remove the ratchet O and substitute in its place another one of larger or smaller diameter or different teeth, according as it is desired to increase or decrease the number of teeth to the inch upon the file-blank. The faster or slower the screw N rotates the more or less cuts the tool C is enabled to make in a given distance upon the file-blank.

To vary the rotary surface motion of the blank G, I remove the pulley L and substitute in its place another one of smaller or larger diameter, according as it is desired to increase or decrease the number of rows of teeth, as the slower the blank rotates the more teeth the tool C will be able to cut around its circumference during each rotation. Instead, however, of changing the ratchet wheel, I may use the adjustable fulcrum R', (shown in Figs. 3 and 4,) which, as shown, is movable in the frame, and also in the slot in lever R, so as to vary the action of the pawl on the ratchet.

The teeth will be cut in straight rows, or spirally, according to the relative adjustment of the feeding and turning mechanisms. For instance, if the pulley L has the same diameter as the pulley b, which operates the cam E, or if the pulley L is twice the diameter of the pulley b, then the teeth will be cut upon the blank in straight rows; but if the sizes of the two pulleys are changed so that the measure-

ment of one is not a multiple of the measurement of the other, then the rows of teeth will be cut spirally in proportion to such variation, as will be readily understood.

What I claim as my invention, and desire to secure by Letters Patent, is—

1. The combination of the rotatable arbor, a traveling block, a screw for working the traveling block, and devices, substantially as described, for varying the relative rotation of the screw and arbor.

2. The combination of the arbor H, screw N, intermediate block, V, and mechanism, substantially as described, to give an independent feed-motion to the independently-rotating arbor H, for the purpose specified.

3. The combination, with a table or analogous supporting means having the slot W, of the rotatable arbor H, the slide J, the screw N, means for rotating the same, and the block V, engaging with said screw, and also engaging with the arbor, said block V and slide J resting and moving in slot W.

4. The combination, with the rotatable arbor H and rotatable screw N, of the intermediate block, V, having a vertically-movable screw-threaded portion, as described, and the cam X, for causing said movable portion to be engaged or disengaged with the screw N.

CRAWFORD M. FAIRBANKS.

Witnesses:

WALTER B. VINCENT,
JAMES D. O'HERN.