



US009233630B2

(12) **United States Patent**  
**Amirault et al.**

(10) **Patent No.:** **US 9,233,630 B2**  
(45) **Date of Patent:** **Jan. 12, 2016**

- (54) **BELT-POSITIONING BOOSTER SEAT FOR VEHICLES**
- (71) Applicant: **Cosco Management, Inc.**, Wilmington, DE (US)
- (72) Inventors: **David M Amirault**, Indianapolis, IN (US); **Kelley L Clayburn**, Hope, IN (US); **Meihui Lin**, Nashville, IN (US)
- (73) Assignee: **Dorel Juvenile Group, Inc.**, Foxboro, MA (US)
- (\* ) Notice: Subject to any disclaimer, the term of this patent is extended or adjusted under 35 U.S.C. 154(b) by 101 days.

5,868,463	A *	2/1999	MacKenzie et al. ....	297/228.12
5,868,465	A *	2/1999	Kvalvik .....	A47D 15/006
				297/228.1
6,082,819	A *	7/2000	Jackson .....	B60N 2/2821
				297/250.1
D461,646	S	8/2002	Kain	
6,832,813	B2	12/2004	Tomas et al.	
6,935,685	B2	8/2005	Kassai et al.	
7,222,917	B2	5/2007	Ward	
7,331,633	B2	2/2008	Balensiefer et al.	
7,708,342	B2	5/2010	Leach	
7,770,969	B2 *	8/2010	Boyle et al. ....	297/254
8,132,863	B2 *	3/2012	Surgeon et al. ....	297/473
8,833,854	B2 *	9/2014	Lu .....	A47D 1/103
				297/253
9,033,420	B2 *	5/2015	Lievstro et al. ....	297/452.48
2002/0017808	A1	2/2002	Kain	
2002/0038968	A1 *	4/2002	Maier .....	B60N 2/2821
				297/253
2003/0102702	A1	6/2003	Daley et al.	
2004/0178668	A1	9/2004	Kassai et al.	
2004/0239166	A1	12/2004	Kihlberg et al.	
2007/0046084	A1 *	3/2007	Leach .....	297/250.1
2007/0096519	A1 *	5/2007	Conforti .....	297/218.2
2007/0152479	A1 *	7/2007	Howman et al. ....	297/180.11
2008/0135593	A1	6/2008	Munther	
2008/0258524	A1	10/2008	Zink et al.	
2011/0291450	A1 *	12/2011	Gillett et al. ....	297/250.1
2012/0019033	A1	1/2012	Kelly	

- (21) Appl. No.: **14/198,137**
- (22) Filed: **Mar. 5, 2014**
- (65) **Prior Publication Data**  
US 2014/0252825 A1 Sep. 11, 2014
- Related U.S. Application Data**
- (60) Provisional application No. 61/772,941, filed on Mar. 5, 2013, provisional application No. 61/889,989, filed on Oct. 11, 2013.

- (51) **Int. Cl.**  
*A47C 1/08* (2006.01)  
*B60N 2/28* (2006.01)  
*B60R 22/26* (2006.01)

- (52) **U.S. Cl.**  
CPC ..... *B60N 2/2866* (2013.01); *B60N 2/2806* (2013.01); *B60R 22/26* (2013.01)

- (58) **Field of Classification Search**  
CPC ..... B60R 22/26  
USPC ..... 297/250.1, 483, 256.16, 253, 485  
See application file for complete search history.

- (56) **References Cited**  
U.S. PATENT DOCUMENTS

4,836,605 A 6/1989 Greenwood et al.  
5,499,860 A \* 3/1996 Smith et al. .... 297/255

\* cited by examiner  
  
*Primary Examiner* — Syed A Islam  
(74) *Attorney, Agent, or Firm* — Barnes & Thornburg LLP

(57) **ABSTRACT**  
A belt-positioning booster seat is adapted to be positioned on a passenger seat included in a vehicle and to support a child seated on the passenger seat. The belt-positioning booster seat includes a seat pad to elevate a child above a seat bottom of the passenger seat along with left and right belt guides adapted to receive a lap belt that extends over a child seated on the seat pad.

**24 Claims, 11 Drawing Sheets**

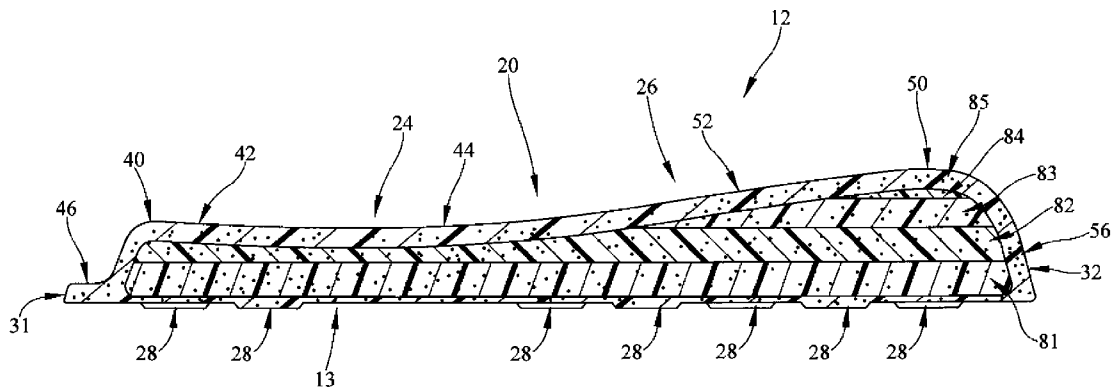

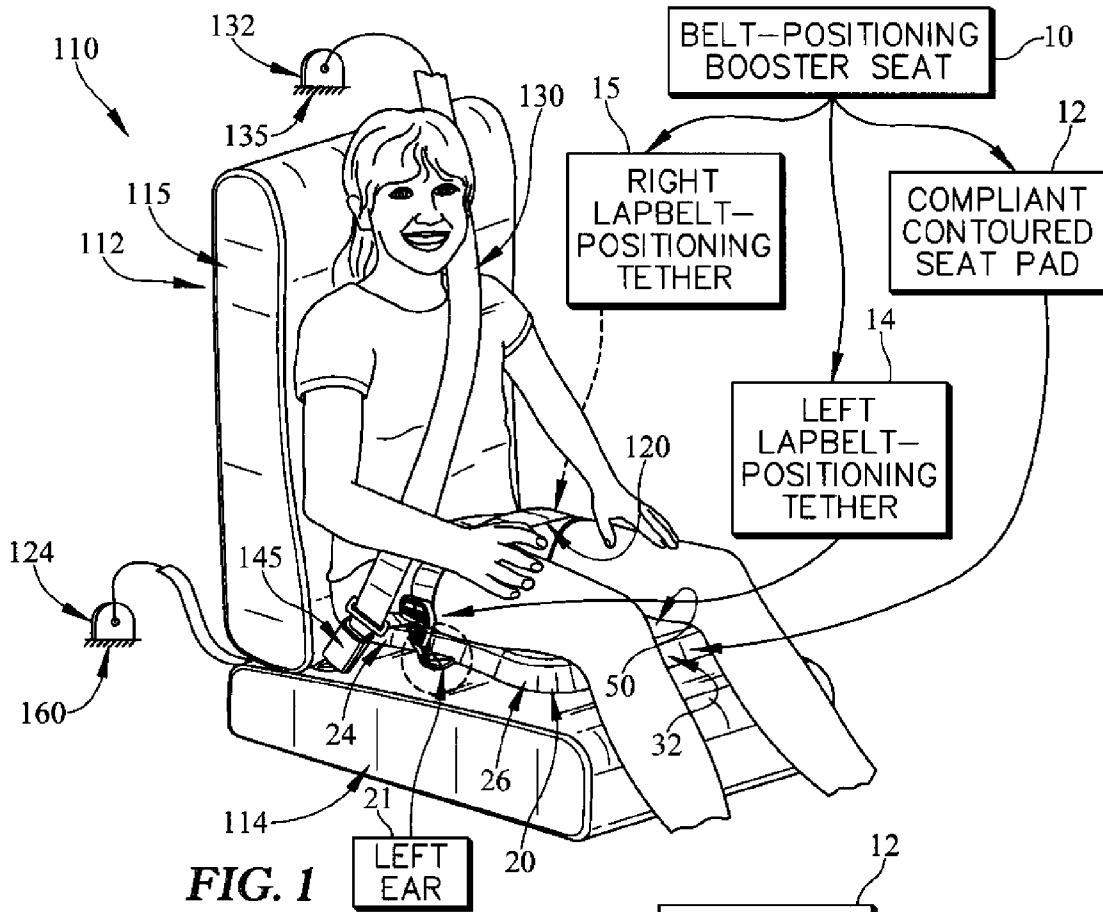

FIG. 1

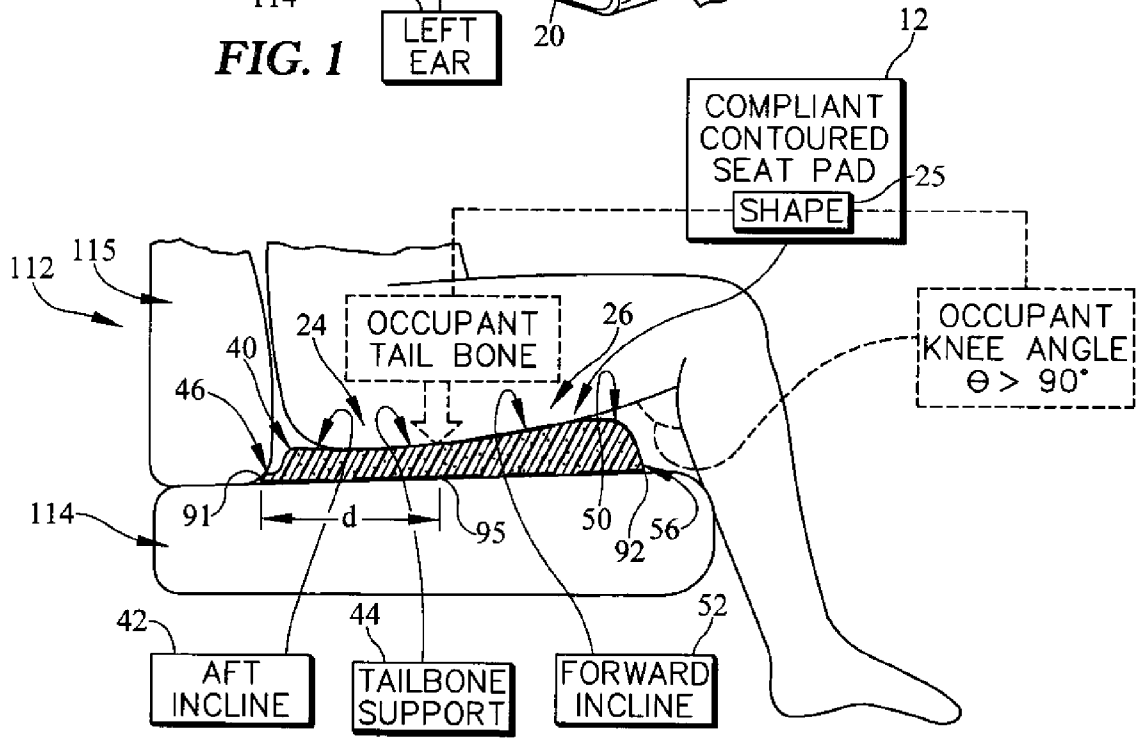

FIG. 2

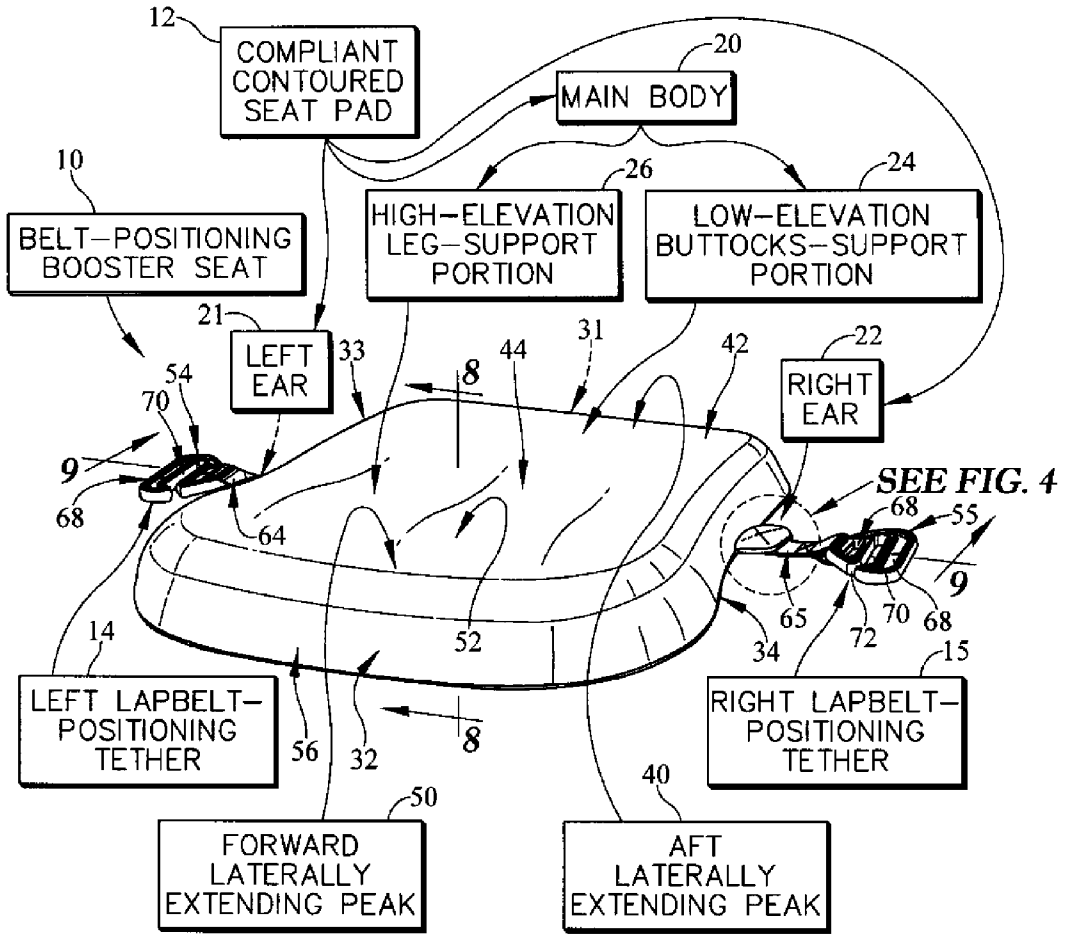

FIG. 3

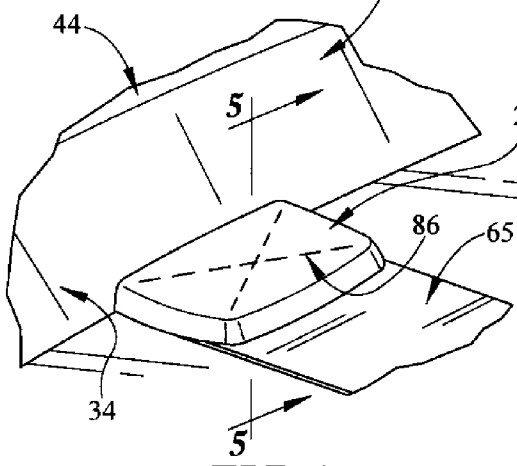

FIG. 4

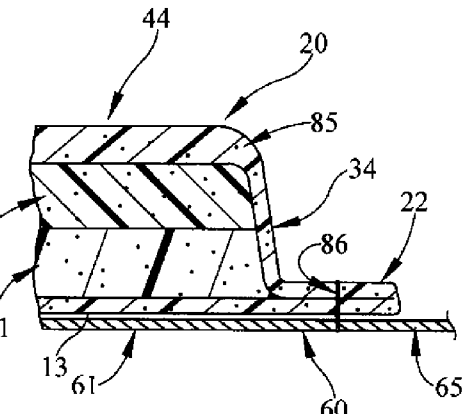

FIG. 5

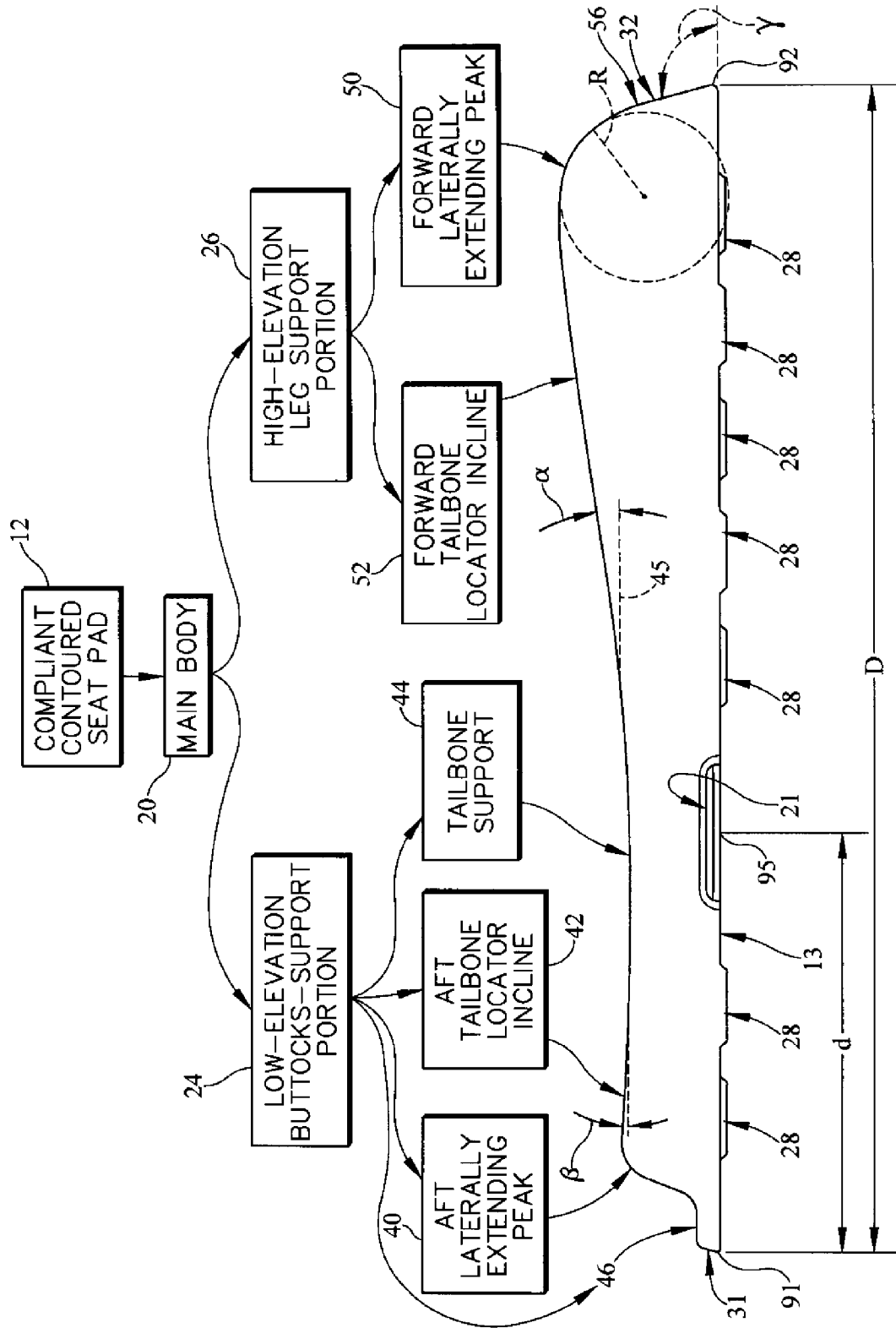

FIG. 6







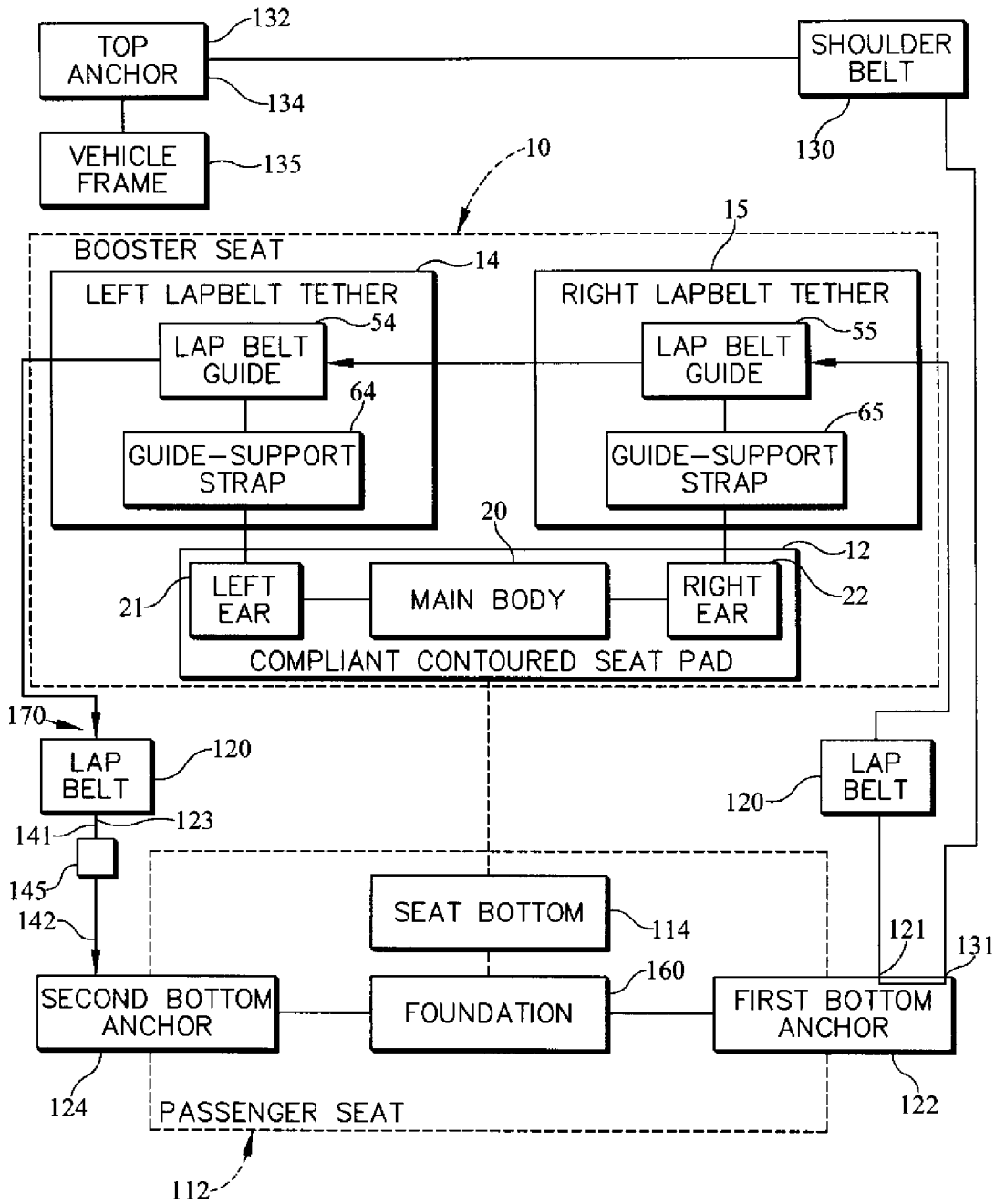

FIG. 12

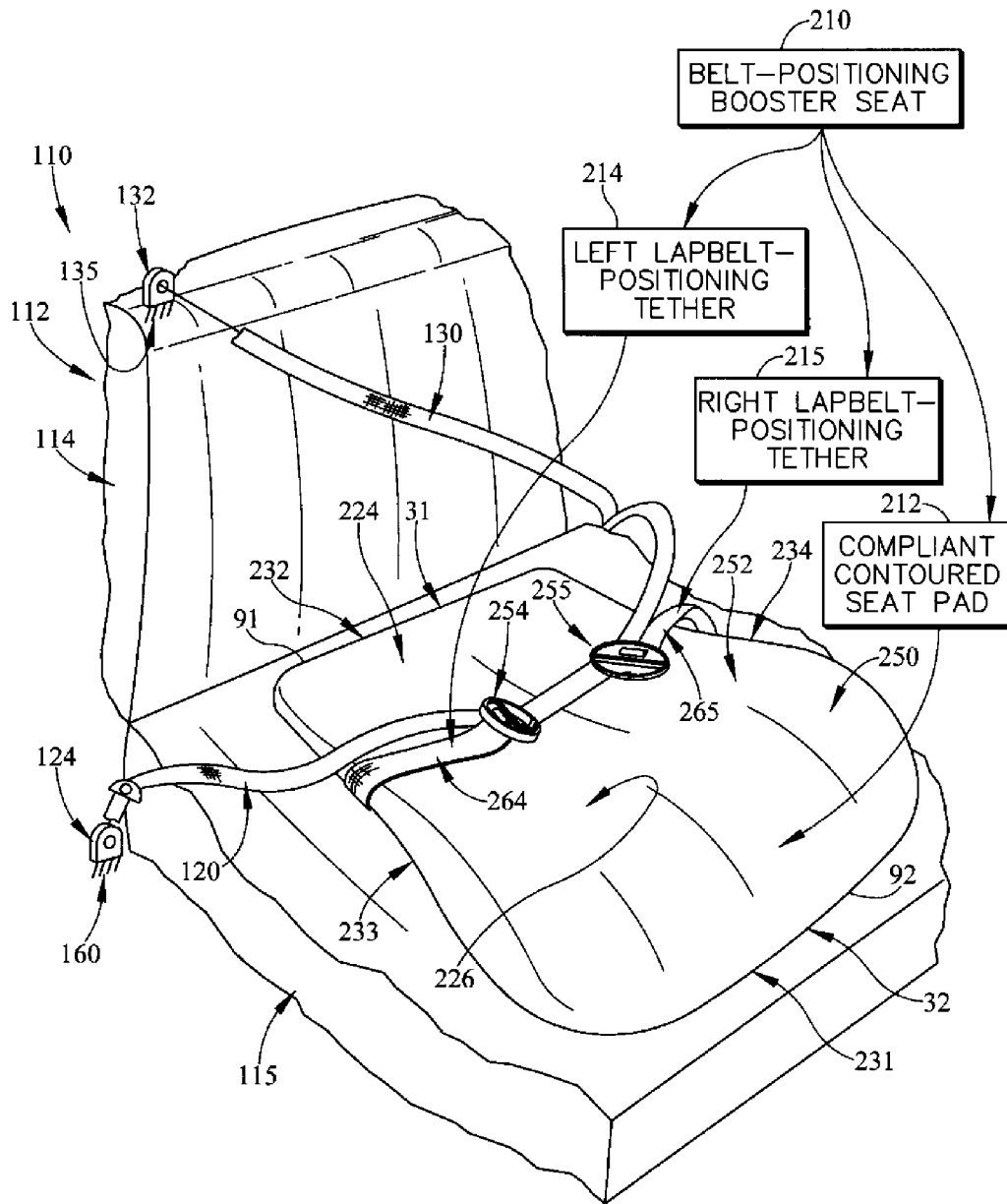

FIG. 13

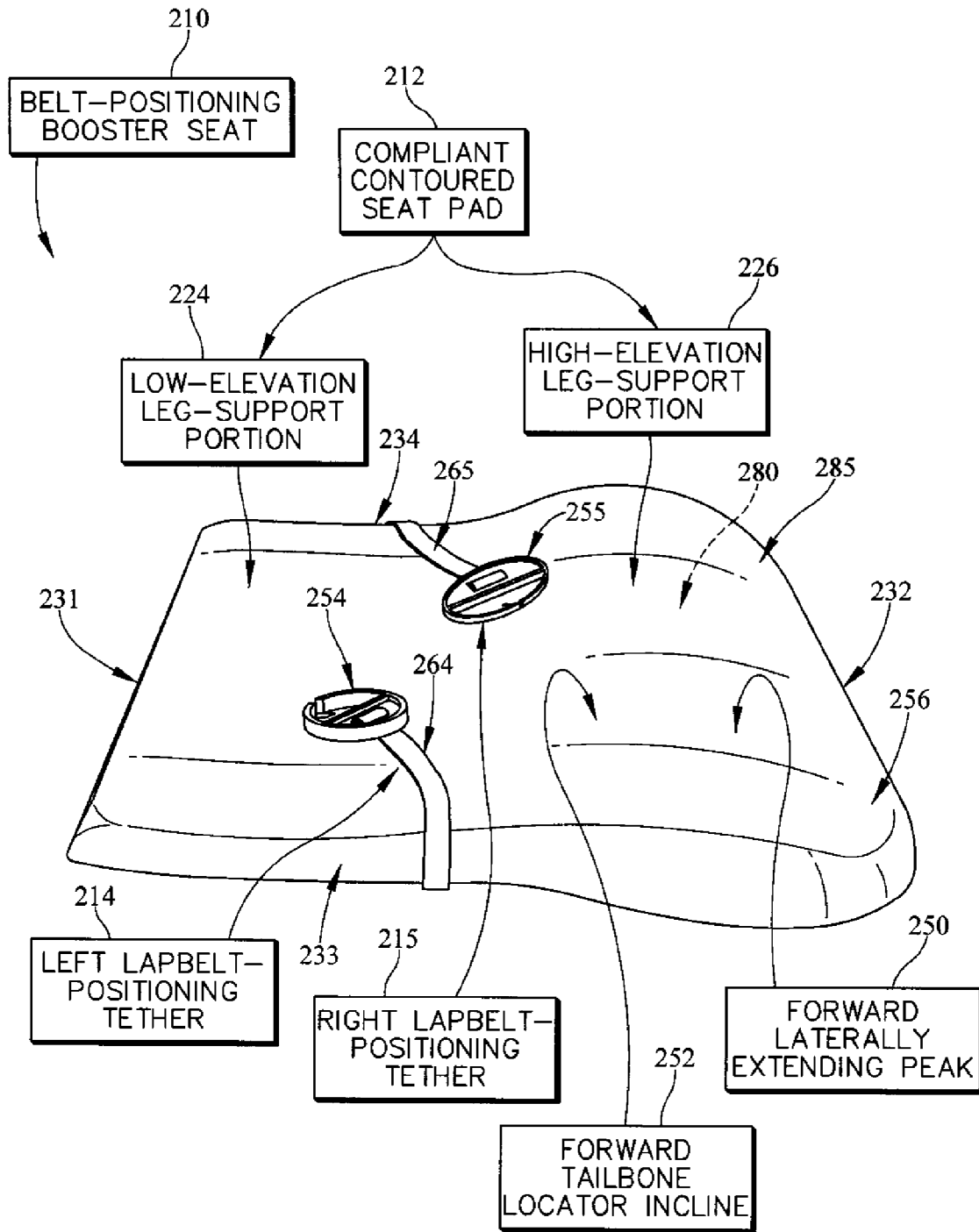
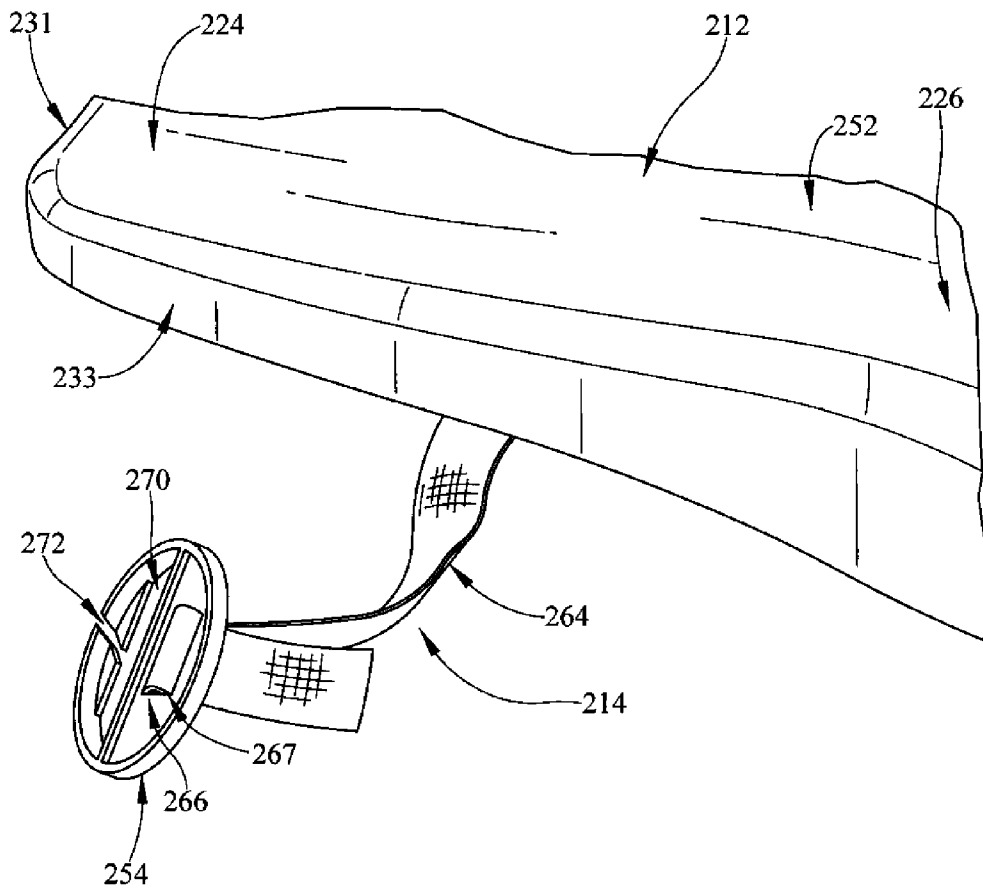

FIG. 14



**FIG. 15**

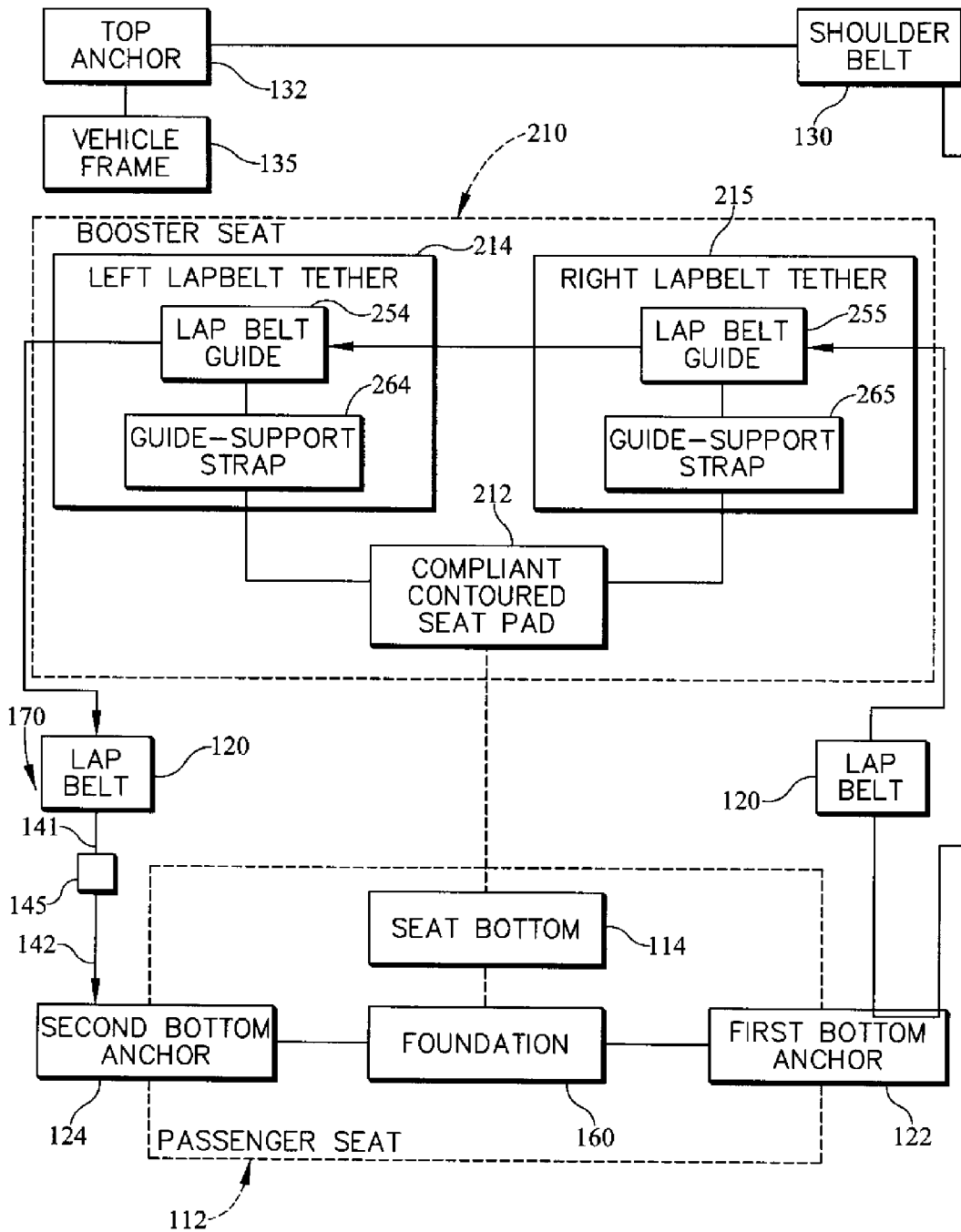

FIG. 16

1

**BELT-POSITIONING BOOSTER SEAT FOR VEHICLES**

## PRIORITY CLAIM

This application claims priority under 35 U.S.C. §119(e) to U.S. Provisional Application Ser. No. 61/772,941, filed Mar. 5, 2013, and to U.S. Provisional Application Ser. No. 61/889,989, filed Oct. 11, 2013, which are expressly incorporated by reference herein.

## BACKGROUND

The present disclosure relates to child passenger seats, and particularly to a system for retaining a child passenger seat in place on a passenger seat in a vehicle. More particularly, the present disclosure relates to a system for positioning a seat belt provided alongside a passenger seat in a vehicle relative to a child seated on a child passenger seat placed on the passenger seat.

## SUMMARY

According to the present disclosure, a belt-positioning booster seat is adapted for use with a passenger seat in a vehicle having a seat bottom and a seat back. The belt-positioning booster seat includes a seat pad along with left and right lap belt-positioning tethers that extend from the seat pad. The seat pad elevates the child above the seat bottom of the passenger seat. The left and right lap belt-positioning tethers receive and guide a lap belt across a child seated on the belt-positioning booster seat.

In illustrative embodiments, the shape of the seat pad is contoured in accordance with the present disclosure to position the tailbone of a child seated on the seat pad in a predetermined location in close proximity to a rear edge of the seat pad next to the seat back of an underlying passenger seat. The seat pad includes a low-elevation tailbone support, an aft tailbone-locator incline arranged to extend upwardly in a rearward direction from the tailbone support toward the seat back, and a forward tailbone locator incline arranged to extend upwardly from the low-elevation tailbone support in a forward direction away from the seat back. The low-elevation tailbone support is shaped and arranged to locate the tailbone of the seat occupant at a certain distance from the rear edge of the seat pad.

In illustrative embodiments, the seat pad includes a body, a left ear that extends outwardly from a left side of the body, and a right ear that extends outwardly from a right side of the body. The body of the seat pad is formed to include the low-elevation tailbone support, the aft tailbone-locator incline, and the forward tailbone-locator incline. The left and right ears are thinner than the body of the seat pad. The reduced thickness of the left and right ears allows stitches of thread to extend through left and right ears and through the left and right lap belt-positioning tethers to secure the left and right lap belt-positioning tethers to the left and right ears.

In illustrative embodiments, the seat pad is constructed from compliant foam materials so that the seat pad yields elastically when a child sits on the seat pad. The seat pad illustratively includes a plurality of shaped foam layers received in a foam cover that cooperate to provide the body of the seat pad. The cover illustratively extends away from the body of the seat pad without receiving any shaped foam layers to provide the left and right ears that are secured to the left and right lap belt-positioning tethers by stitches of thread.

2

Additional features of the present disclosure will become apparent to those skilled in the art upon consideration of illustrative embodiments exemplifying the best mode of carrying out the disclosure as presently perceived.

## BRIEF DESCRIPTIONS OF THE DRAWINGS

The detailed description particularly refers to the accompanying figures in which:

FIG. 1 is a perspective view of a belt-positioning booster seat in accordance with the present disclosure at rest on a seat bottom of a passenger seat in a vehicle supporting a child showing that the booster seat includes a compliant contoured seat pad adapted to elevate the child above the seat bottom of the passenger seat, a left lap belt-positioning tether coupled to the compliant contoured seat pad, and a right lap belt-positioning tether coupled to the compliant contoured seat pad and showing the first and the second lap belt-positioning tethers receiving and guiding a lap belt across thighs of a child seated on the compliant contoured seat pad;

FIG. 2 is a cross-sectional view of the belt-positioning booster seat of FIG. 1 showing that the compliant contoured seat pad is made from compliant foam materials and is shaped to locate a child's tailbone on the compliant contoured seat pad at a predetermined distance from a rear edge of the compliant contoured seat pad and to guide the thighs and the lower legs of the child to form a slightly obtuse knee angle between the thighs and lower legs so that the child's legs transition smoothly toward the front of the seat bottom included in the passenger seat;

FIG. 3 is a perspective view of the compliant contoured seat pad, the left lap belt-positioning tether, and the right lap belt-positioning tether included in the belt-positioning booster seat of FIGS. 1 and 2 showing that the compliant contoured seat pad includes a body having a low-elevation buttocks-support portion and a high-elevation leg-support portion, a left ear that is secured to the left lap belt-positioning tether, and a right ear that extends from the body that is secured to the right lap belt-positioning tether;

FIG. 4 is a detailed view of a portion of the belt-positioning booster seat of FIG. 3 showing that the right ear of the compliant contoured seat pad is thinner than the body of the compliant contoured seat pad and showing that the right ear is secured to the right lap belt-positioning tether by a series of stitches;

FIG. 5 is a cross-sectional view taken along line 5-5 shown in FIG. 4 showing that the stitches securing the right ear to the right lap belt-positioning tether extend through the right ear and the right lap belt-positioning tether;

FIG. 6 is a side elevation view of the compliant contoured seat pad showing that the low-elevation buttocks-support portion includes an aft laterally extending peak, a tailbone support adapted to underlie a child's tailbone and arranged at a preselected location between a front and a back of the compliant contoured seat pad, and an aft tailbone-locator incline sloping between the aft laterally extending peak and the tailbone support to encourage location of a child's tailbone on the tailbone support of the low-elevation buttocks-support portion and showing that the high-elevation buttocks-support portion includes a forward laterally extending peak and a forward tailbone-locator incline sloping between the forward laterally extending peak and the tailbone support to encourage location of a child's tailbone on the tailbone support of the low-elevation buttocks-support portion;

FIG. 7 is a view similar to FIG. 6 on a grid background to illustrate the shape of the compliant contoured seat pad showing that the aft tailbone-locator incline is arranged to extend

3

upwardly from the tailbone support toward the aft laterally extending peak forming a first angle  $\beta$  between the tailbone support and the aft tailbone-locator incline, showing that the forward tailbone-locator incline section is arranged to extend upwardly from the tailbone-tailbone support toward the forward laterally extending peak forming a second angle  $\alpha$  the tailbone-tailbone support and the forward tailbone-locator incline, and further showing that the forward laterally extending peak is arranged to extend along a radius R;

FIG. 8 is a cross-sectional view of the contoured compliant seat pad included in the belt-positioning booster seat of FIG. 3 taken along line 8-8 showing that the seat pad is made from a series of shaped layers arranged inside a cover and showing that the layers are sized and arranged to define the contour of the body of the compliant contoured seat pad;

FIG. 9 is a cross-sectional view of the belt-positioning booster seat of FIG. 3 taken along line 9-9 showing that neither the right ear nor the left ear of the contoured seat pad receive any shaped layers as are received in the body of the compliant contoured seat pad;

FIG. 10 is a bottom perspective view of the belt-positioning booster seat of FIGS. 1 and 3 showing that each of the first and second lap belt-positioning tethers include a corresponding portion of a single lap belt strap and a corresponding lap belt guide configured to receive a lap belt and showing that the lap belt strap extends along the underside of the contoured compliant seat pad to provide a handle for a caregiver transporting the belt-positioning booster seat;

FIG. 11 is a top plan view of one of the lap belt guides showing that the lap belt guide is a monolithic component formed to include an aperture sized to receive the lap belt strap, a grip sized to be held by a child hand, and a belt-receiver slot arranged between the aperture and the grip and showing that the belt-receiver slot is accessible through a diagonal belt-travel slot communicating with the belt-receiver slot to allow a child to slide a lap belt into the belt-receiver slot;

FIG. 12 is a diagrammatic view of the belt-positioning booster seat of FIG. 1 in combination with a passenger seat and a passenger restraint harness system including a lap and shoulder belt and various top and bottom belt anchors associated with the passenger seat;

FIG. 13 is a perspective view of another belt-positioning booster seat in accordance with the present disclosure at rest on a seat bottom of a passenger seat in a vehicle showing that the booster seat includes a compliant contoured seat pad adapted to elevate a child supported on the belt-positioning booster seat above the seat bottom of the passenger seat, a left lap belt-positioning tether coupled to the compliant contoured seat pad, and a right lap belt-positioning tether coupled to the compliant contoured seat pad and showing the first and the second lap belt-positioning tethers receiving and guiding a lap belt across the compliant contoured seat pad;

FIG. 14 is a top perspective view of the belt-positioning booster seat of FIG. 13 showing that the compliant contoured seat pad includes a low-elevation buttocks-support portion and a high-elevation leg-support portion and showing that the high-elevation leg-support portion comprises a laterally extending peak and a forward tailbone-locator incline sloping between the low-elevation buttocks-support portion and the forward laterally extending peak to encourage location of a child's tailbone on the low-elevation buttocks-support portion of the compliant contoured seat pad;

FIG. 15 is an enlarged view of one of the belt-positioning tethers of FIGS. 13 and 14 showing that the belt-positioning tether includes a lap belt guide formed to include a belt-receiver slot and a diagonal belt-travel slot communicating

4

with the belt-receiver slot and a lap belt strap coupled at one end to a first side of the seat pad and at an opposite end to the lap belt guide in a manner that allows a caregiver to vary an effective length of the guide-support strap; and

FIG. 16 is a diagrammatic view of the belt-positioning booster seat of FIG. 13 in combination with a passenger seat and a passenger restraint harness system including a lap and shoulder belt and various top and bottom belt anchors associated with the passenger seat.

#### DETAILED DESCRIPTION

An illustrative belt-positioning booster seat 10 in accordance with the present disclosure is adapted to be arranged on a seat bottom 114 of a passenger seat 112 along a seat back 115 of passenger seat 112 in a vehicle 110 to support a child in the vehicle 110 as shown in FIG. 1. Belt-positioning booster seat 10 includes a compliant contoured seat pad 12, a left lap belt-positioning tether 14, and a right lap belt-positioning tether 15. Compliant contoured seat pad 12 has a preselected shape 25 configured to provide means for positioning a child's tailbone and legs relative to passenger seat 113 so that the child is encouraged to sit up straight and to have a slightly obtuse knee angle as shown in FIG. 2. Belt-positioning tethers 14, 15 receive and guide a lap belt 120 across the thighs of a child seated on compliant contoured seat pad 12 so that the lap belt 120 is maintained in spaced apart relation to the midsection of the child without requiring an armrest or hard guide.

Compliant contoured seat pad 12 is adapted to elevate the child above seat bottom 114 of passenger seat 112 and is formed to include a body 20, a left ear 21, and a right ear 22 as shown, for example, in FIG. 3. Body 20 of compliant contoured seat pad 12 is adapted to position the child on passenger seat 112. Body 20 illustratively includes an aft tailbone-locator incline 42 that slopes downwardly from behind a tailbone support 44 of body 20 to locate the tailbone of a child over tailbone support 44. Body 20 also includes a forward tailbone-locator incline 52 that slopes downwardly from in front of tailbone support 44 to locate the tailbone of a child over tailbone support 44.

Left and right ears 21, 22 of compliant contoured seat pad 12 are secured to left and right lap belt-positioning tethers 14, 15, respectively, by stitches of thread 86 so that lap belt-positioning tethers 14, 15 are coupled to compliant contoured seat pad 12 as shown in FIGS. 3-5. The left and right ears 21, 22 have a reduced thickness when compared body 20 so that stitches of thread 86 can extend through left and right ears 21, 22 along with left and right lap belt-positioning tethers 14, 15.

Compliant contoured seat pad 12 is illustratively constructed from foam materials without hardened supports so that compliant contoured seat pad 12 yields elastically when a child sits on belt-positioning booster seat 10 as suggested in FIG. 1. In the illustrative embodiment, compliant contoured seat pad 12 includes a plurality of shaped layers 81, 82, 83, 84 made of foam received in a cover 85 made from foam that cooperate to provide body 20 of compliant contoured seat pad 12. Cover 85 extends away from body 20 without receiving any shaped layers to provide left and right ears 21, 22 of compliant contoured seat pad 12.

Body 20 of compliant contoured seat pad 12 is adapted to underlie a child supported on belt-positioning booster seat 10 and illustratively includes a low-elevation buttocks-support portion 24 and a high-elevation leg-support portion 26 as shown in FIG. 3. Low-elevation buttocks-support portion 24 forms a back 31 of compliant contoured seat pad 12 and is adapted to underlie the buttocks of a child seated on compli-

5

ant contoured seat pad 12. High-elevation leg-support portion 26 forms a front 32 of compliant contoured seat pad 12 and is adapted to support the legs of a child seated on compliant contoured seat pad 12 at an elevation generally greater than that of the low-elevation buttocks-support portion 24. In the illustrative embodiment, low-elevation buttocks-support portion 24 is narrower than high-elevation leg-support portion 26 between a left side 33 and a right side 34 of compliant contoured seat pad 12.

Low-elevation buttocks-support portion 24 of body 20 included in compliant contoured seat pad 12 illustratively extends about half way from back 31 of compliant contoured seat pad 12 toward front 32 of compliant contoured seat pad 12 as shown in FIGS. 6 and 7. Low-elevation buttocks-support portion 24 includes an aft laterally extending peak 40, an aft tailbone-locator incline 42 that extends forwardly from aft laterally extending peak 40, and a tailbone support 44 that extends forwardly from aft tailbone-locator incline 42. Aft laterally extending peak 40 extends between a left side 33 and a right side 34 of compliant contoured seat pad 12 along back 31 of compliant contoured seat pad 12. Aft tailbone-locator incline 42 extends downwardly from aft laterally extending peak 40 to tailbone support 44.

Aft tailbone-locator incline 42 provides a downward slope from aft laterally extending peak 40 to tailbone support 44 as shown in FIGS. 6 and 7. Aft tailbone-locator incline 42 provides means for locating the tailbone of a child forward of aft laterally extending peak 40 and over tailbone support 44 of rear low-elevation buttocks-support portion 24 when the child is seated on the belt-positioning booster seat 10 so that so that the tailbone of the child is located in a preselected position on an underlying passenger seat 112 and the child is encouraged to sit up straight. In the illustrative embodiment, aft tailbone-locator incline 42 forms an angle  $\beta$  of about 5.5 degrees defined between a generally flat plane 45 tangent to tailbone support 44 of low-elevation buttocks-support portion 24 and the top of aft tailbone-locator incline 42.

Tailbone support 44 is illustratively located around a location reference line 95 associated with tailbone support 44 and reference line 95 extends from the left side 33 to the right side 34 of compliant seat pad 12 as shown in FIG. 6. The reference line 95 is illustratively spaced a predetermined distance  $d$  from a rear edge 91 of compliant contoured seat pad 12 as shown in FIG. 6. The predetermined distance  $d$  is generally equivalent to the distance from seat back 115 to the tailbone of a child seated on the compliant contoured seat pad 12 and is calculated to encourage the child to sit up straight with the back of the child extending upwardly along seat back 115 rather than slouching forward or backward.

In the illustrative embodiment, distance  $d$  from rear edge 91 of compliant contoured seat pad 12 to location reference line 95 associated with tailbone support 44 may be about 18 millimeters. In the illustrative embodiment, compliant contoured seat pad 12 had a depth  $D$  from rear edge 91 to a front edge 92 of about 47 millimeters. Thus, in the illustrative embodiment the distance  $d$  is about 40 percent of the depth  $D$  of the entire compliant contoured seat pad 12 as shown in FIGS. 6 and 7.

Low-elevation buttocks-support portion 24 in the illustrative embodiment further includes a thinned heel 46 as shown in FIGS. 6 and 7. Thinned heel 46 extends rearwardly from aft laterally extending peak 40 and forms back 31 of compliant contoured seat pad 12. Thinned heel 46 is thinner from top to bottom than the rest of low-elevation buttocks-support portion 24 of body 20 included in compliant contoured seat pad 12 and is adapted to contact seat back 115 of passenger seat 112 at the intersection of seat back 115 with seat bottom 114

6

as shown in FIG. 2. In the illustrative embodiment, the thinned heel 46, the aft laterally extending peak 40, and the aft tailbone-locator incline 42 cooperate to extend about one-fourth of the entire depth  $D$  of the compliant contoured seat pad 12 as shown in FIGS. 6 and 7.

High-elevation leg-support portion 26 of body 20 included in compliant contoured seat pad 12 illustratively extends about half way from front 32 of compliant contoured seat pad 12 toward back 31 of compliant contoured seat pad 12 as shown in FIGS. 6 and 7. High-elevation leg-support portion 26 includes a forward laterally extending peak 50 and a forward tailbone-locator incline 52 that extends rearwardly from forward laterally extending peak 50. Forward laterally extending peak 50 extends between left side 33 and right side 34 of compliant contoured seat pad 12 along front 32 of compliant contoured seat pad 12. Forward tailbone-locator incline 52 extends downwardly from forward laterally extending peak 50 to tailbone support 44 included in low-elevation buttocks-support portion 24 of the compliant contoured seat pad 12.

Forward laterally extending peak 50 forms the top elevation of the compliant contoured seat pad 12 and extends along a curved radius  $R$  at the top elevation. In the illustrative embodiment, the curve radius of forward laterally extending peak 50 is about 37.5 millimeters at the top elevation of the compliant contoured seat pad 12. Forward laterally extending peak 50 cooperates with forward tailbone-locator incline 52 to provide means for angling the thighs of a child upward from tailbone support 44 of low-elevation buttocks-support portion 24 causing the thighs of the child to form a slightly obtuse angle  $\theta$  with lower legs of the child when the child is seated on the belt-positioning booster seat 10 so that the lower legs of the child are guided along a smooth transition toward a front of seat bottom 114 included in the passenger seat 112 underlying the belt-positioning booster seat 10.

Forward tailbone-locator incline 52 slopes downwardly from forward laterally extending peak 50 to tailbone support 44 of low-elevation buttocks-support portion 24 as shown in FIGS. 6 and 7. Forward tailbone-locator incline 52 provides positioning means for locating the tailbone of a child rearward of high-elevation leg-support portion 26 over tailbone support 44 of low-elevation buttocks-support portion 24 so that the tailbone of the child is located in a preselected position on an underlying passenger seat 112 and the child is encouraged to sit up straight on passenger seat 112 as suggested in FIGS. 1 and 2. In the illustrative embodiment, forward tailbone-locator incline 52 forms an angle  $\alpha$  of about 9.2 degrees defined between generally flat plane 45 tangent to tailbone support 44 of low-elevation buttocks-support portion 24 and the top of forward tailbone-locator incline 52.

High-elevation leg-support portion 26 in the illustrative embodiment further includes a sloped toe 56 that extends from forward laterally extending peak 50 to front 32 of compliant contoured seat pad 12 as shown in FIGS. 6 and 7. Sloped toe 56 slopes downwardly from forward laterally extending peak 50 and is shaped to form an obtuse angle  $\gamma$  with seat bottom 114 when compliant contoured seat pad 12 is arranged on seat bottom 114.

Body 20 of compliant contoured seat pad 12 in the illustrative embodiment further includes slip-reducer feet 28 that extend downwardly from an underside 13 of low-elevation buttocks-support portion 24 and from high-elevation leg-support portion 26 as shown in FIGS. 6, 7, and 10. Slip-reducer feet 28 engage seat bottom 114 when compliant contoured seat pad 12 is arranged on seat bottom 114 to prevent compliant contoured seat pad 12 from sliding over seat bottom 114.

Left lap belt-positioning tether **14** and right lap belt-positioning tether **15** extend outward from body **20** along corresponding left and right sides **33, 34** of compliant contoured seat pad **12** as shown in FIGS. **3, 6, and 10**. Each of left lap belt-positioning tether **14** and right lap belt-positioning tether **15** include a lap belt guide **54, 55** and a portion **64, 65** of a single lap belt strap **60** as shown in FIG. **10**. Lap belt guides **54, 55** are configured to receive and retain lap belt **120**. Each portion **64, 65** of lap belt strap **60** included in a belt-positioning tether **14, 15** extends away from compliant contoured seat pad **12** a preselected distance. A handle portion **61** of the lap belt strap **60** extends from left side **33** to the right side **34** of compliant contoured seat pad **12** along underside **13** of compliant contoured seat pad **12** to provide a handle that can be grasped by a caregiver moving the belt-positioning booster seat **10**.

Lap belt guides **54, 55** are substantially similar to one another as shown in FIG. **3**. The following description of lap belt guide **54** shown in FIG. **111** is equally applicable to lap belt guide **55**. Lap belt guide **54** is a monolithic component formed to include an aperture **66** sized to receive lap belt **120**, a grip **68** sized to be held by a child's hand, and a belt-receiver slot **70** arranged between the aperture **66** and the grip **68**. Belt-receiver slot **70** is accessible through a diagonal belt-travel slot **72** communicating with the belt-receiver slot **70** to allow a child to slide lap belt **120** into the belt-receiver slot **70**.

In the illustrative embodiment, compliant contoured seat pad **12** includes a plurality of shaped layers **81, 82, 83, 84** received in a cover **85** as shown, for example, in FIGS. **8 and 9**. Shaped layers **81, 82, 83, 84** and cover **85** are illustratively constructed from olefin foam without hardened reinforcements so that compliant contoured seat pad **12** has a preselected compliance and yields elastically when a child sits on the compliant contoured seat pad **12**. In other embodiments, other types of foams and/or other suitable materials may be used to construct compliant contoured seat pad **12** without hardened reinforcements. In some embodiments, hardened reinforcements made from plastics or other materials may be added to compliant contoured seat pad **12**.

Shaped layers **81, 82, 83, 84** are arranged within body **20** of compliant contoured seat pad **12** and are sized to define the shape of body **20** such that compliant contoured seat pad **12** provides means for positioning the child on passenger seat **112** as shown in FIG. **8**. More particularly, shaped layers **81, 82, 83, 84** are shaped to form aft laterally extending peak **40**, aft tailbone-locator incline **42**, and tailbone support **44** of low-elevation buttocks-support portion **24** as well as forward laterally extending peak **50** and forward tailbone-locator incline **52** of high-elevation leg-support portion **26**.

Cover **85** illustratively receives shaped layers **81, 82, 83, 84** to form body **20** of compliant contoured seat pad **12** and forms left and right ears **21, 22** of compliant contoured seat pad **12** as shown in FIG. **9**. Cover **85** extends outwardly from tailbone support **44** of low-elevation buttocks-support portion **24** included in body **20** along left and right sides **33, 34** of compliant contoured seat pad **12** to forms left and right ears **21, 22** of compliant contoured seat pad **12**. Cover **85** also forms slip-reducer feet **28**.

Left and right ears **21, 22** of compliant contoured seat pad **12** formed by cover **85** do not receive any shaped layers **81, 82, 83, 84** so that left and right ears **21, 22** are thinner than body **20** as shown in FIGS. **5 and 9**. On account of the thinned left and right ears **21, 22**, stitches of thread **86** that extends through lap belt strap **60** and left or right ears **21, 22** is used to secure left and right lap belt-positioning tethers **14, 15** to the left and right ears **21, 22**, respectively, of the compliant contoured seat pad **12** as suggested in FIG. **4**. In other embodi-

ments, adhesives and other coupling arrangements may be used to couple left and right lap belt-positioning tethers **14, 15** to the compliant contoured seat pad **12**.

As suggested diagrammatically in FIG. **12**, passenger seat **112** includes a first bottom anchor **122** secured to a foundation **160** in a fixed position relative to seat bottom **114** and a second bottom anchor **124** secured to a foundation **160** in a fixed position and in spaced-apart relation to first bottom anchor **122**. As suggested in FIG. **1**, first bottom anchor **122** is positioned to lie in a crevice **125** formed between seat bottom **114** and seat back **115**. Second bottom anchor **124** is arranged to lie in the crevice **125** alongside a portion of seat bottom **114** as also suggested in FIG. **1**.

As suggested in FIGS. **1 and 12**, a shoulder belt **130** includes an upper end **131** coupled in a suitable manner to a top anchor **134** that is secured to a vehicle frame **135** and a lower end **132** coupled in a suitable manner to first bottom anchor **122**. Lap belt **120** includes a first end **121** coupled to first bottom anchor **122** (and/or lower end of shoulder belt **130**) and a second end **123** coupled to second bottom anchor **124**. As suggested in FIGS. **1 and 5**, a seat belt **150** including lap belt **120** and shoulder belt **130** can also include a first strap **141** coupled to first bottom anchor **122**, a second strap **142** coupled to second bottom anchor **124**, and a buckle unit **145** configured to releasably couple first strap **141** to second strap **142** in a customary manner.

Compliant contoured seat pad **12** is a low-profile component that blends in with seat bottom **114** of passenger seat **112**. Compliant contoured seat pad **12** is shaped with contours to fit a child that is not quite tall enough to fit properly in a passenger-restraint harness system **170** while seated on a passenger seat **112**. This contour (as shown, for example, in FIGS. **6 and 7**) prevents slouching which might otherwise contribute to raising the lap belt from the thigh region to the abdominal region of a seated child.

Lap belt guides **54, 55** included in tethers **14, 15** cooperate to help place lap belt **120** in a proper position on the thigh region of a child seated on compliant contoured seat pad **12**. The lap belt guides **54, 55** are permanently held to the compliant contoured seat pad **12** with webbing such as guide-support straps **64, 65** that are in turn secured to the compliant contoured seat pad **12** by stitches of thread **68**. Belt-positioning booster seat **10** avoids reliance on armrests or inflation of inflatable features to position the lap belt on a seated child.

According to an aspect of the present disclosure, the shape **25** of the seat pad **12** is contoured to position the tailbone of a child seated on the seat pad **25** in a predetermined location in close proximity to a rear edge **91** of the seat pad **12** next to the seat back **115** of an underlying passenger seat **112** as shown in FIGS. **2, 6, and 7**. The seat pad **12** includes a low-elevation tailbone support **44**, an aft tailbone-locator incline **42** arranged to extend upwardly in a rearward direction from the tailbone support **44** toward the seat back **115**, and a forward tailbone locator incline **52** arranged to extend upwardly from the low-elevation tailbone support **44** in a forward direction away from the seat back **115**. The low-elevation tailbone support **44** is shaped and arranged to locate the tailbone of the seat **112** occupant at a certain distance from the rear edge **91** of the seat pad **12**.

In some embodiments, the seat pad **12** includes a body **20**, a left ear **21** that extend outwardly from a left side **33** of the body **20**, and a right ear **22** that extends outwardly from a right side **34** of the body **20** as shown in FIG. **3**. The body **20** of the seat pad **12** is formed to include the low-elevation tailbone support **44**, the aft tailbone-locator incline **42**, and the forward tailbone-locator incline **52**. The left and right ears **21, 22** are thinner than the body **20** of the seat pad **12**. The reduced

thickness of the left and right ears **21, 22** allows stitches of thread **86** to extend through left and right ears **21, 22** and through the left and right lap belt-positioning tethers **14, 15** to secure the left and right lap belt-positioning tethers **14, 15** to the left and right ears **21, 22**.

In illustrative embodiments, the seat pad **12** is constructed from compliant foam materials so that the seat pad **12** yields elastically when a child sits on the seat pad **12** as shown in FIGS. **2, 8, and 9**. The seat pad **12** illustratively includes a plurality of shaped foam layers **81, 82, 83, 84** received in a foam cover **85** that cooperate to provide the body **20** of the seat pad **12**. The cover **85** illustratively extends away from the body **20** of the seat pad **12** without receiving any shaped foam layers **81, 82, 83, 84** to provide the left and right ears **21, 22** that are secured to the left and right lap belt-positioning tethers **14, 15** by stitches of thread **86**.

Another illustrative belt-positioning booster seat **210** in accordance with the present disclosure is adapted to be arranged on seat bottom **114** of passenger seat **112** along a seat back **115** of passenger seat **112** in vehicle **110** to support a child in the vehicle **110** as shown in FIGS. **13-16**. Belt-positioning booster seat **210** includes a compliant contoured seat pad **212**, a left lap belt-positioning tether **214**, and a right lap belt-positioning tether **215**. Compliant contoured seat pad **212** is adapted to elevate the child above seat bottom **114** of passenger seat **112**. Belt-positioning tethers **214, 215** are adapted to receive and guide lap belt **120** along a preselected path so that lap belt **120** extends across the thighs of a child seated on compliant contoured seat pad **212**.

Compliant contoured seat pad **212** is adapted to underlie a child supported on belt-positioning booster seat **210** and is shaped to provide means for positioning the child on passenger seat **112**. Compliant contoured seat pad **212** illustratively includes a low-elevation buttocks-support portion **224** and a high-elevation leg-support portion **226** as shown in FIG. **14**. Low-elevation buttocks-support portion **224** forms a back **231** of compliant contoured seat pad **212** and is adapted to underlie the buttocks of a child seated on compliant contoured seat pad **212**. High-elevation leg-support portion **226** forms a front **232** of compliant contoured seat pad **212** and is adapted to support the legs of a child seated on compliant contoured seat pad **212** at an elevation generally greater than that of the low-elevation buttocks-support portion **224**.

Low-elevation buttocks-support portion **224** included in compliant contoured seat pad **212** illustratively extends about half way from back **231** of compliant contoured seat pad **212** toward front **232** of compliant contoured seat pad **212** as shown in FIGS. **13 and 14**. Low-elevation buttocks-support portion **224** is adapted to underlie the tailbone of a child seated on belt-positioning booster seat **210** at a preselected location relative to the passenger seat **112** that encourages the child to sit up straight on belt-positioning booster seat **210**.

High-elevation leg-support portion **226** included in compliant contoured seat pad **212** illustratively extends about half way from front **232** of compliant contoured seat pad **212** toward back **231** of compliant contoured seat pad **212** as shown in FIGS. **13 and 14**. High-elevation leg-support portion **226** includes a forward laterally extending peak **250** and a forward tailbone-locator incline **252** that extends rearwardly from forward laterally extending peak **250**. Forward laterally extending peak **250** extends between left side **233** and right side **234** of compliant contoured seat pad **212** along front **232** of compliant contoured seat pad **212**. Forward tailbone-locator incline **252** extends downwardly from forward laterally extending peak **250** to low-elevation buttocks-support portion **224**.

Forward laterally extending peak **250** has a curved convex top surface and forms the top elevation of the compliant contoured seat pad **212**. Forward laterally extending peak **250** cooperates with forward tailbone-locator incline **252** to provide means for angling the thighs of a child upward from low-elevation buttocks-support portion **224** causing the thighs of the child to form a slightly obtuse angle with lower legs of the child when the child is seated on the belt-positioning booster seat **210** so that the lower legs of the child are guided along a smooth transition toward a front of seat bottom **114** included in passenger seat **112** underlying belt-positioning booster seat **210**.

Forward tailbone-locator incline **252** slopes downwardly from forward laterally extending peak **250** to low-elevation buttocks-support portion **224** as shown in FIGS. **13 and 14**. Forward tailbone-locator incline **252** provides positioning means for locating the tailbone of a child rearward of high-elevation leg-support portion **226** over low-elevation buttocks-support portion **224** so that the tailbone of the child is located in a preselected position on an underlying passenger seat **112** and the child is encouraged to sit up straight on passenger seat **112**.

High-elevation leg-support portion **226** in the illustrative embodiment further includes a sloped toe **256** that extends from forward laterally extending peak **250** to front **232** of compliant contoured seat pad **212** as shown in FIGS. **13 and 14**. Sloped toe **256** slopes downwardly from forward laterally extending peak **250** and is shaped to form an obtuse angle with seat bottom **114** when compliant contoured seat pad **212** is arranged on seat bottom **114**.

Left lap belt-positioning tether **214** and right lap belt-positioning tether **215** are coupled to and extend outward from compliant contoured seat pad **212** along corresponding left and right sides **233, 234** of compliant contoured seat pad **212** as shown in FIGS. **13 and 14**. Each of left lap belt-positioning tether **214** and right lap belt-positioning tether **215** include a lap belt guide **254, 255** and a lap belt strap **264, 265** as shown in FIG. **15**. Lap belt guides **54, 55** are configured to receive and retain lap belt **120**. Each lap belt strap **264, 265** extends away from compliant contoured seat pad **212**.

Lap belt guides **254, 255** are substantially similar to one another as shown in FIG. **15**. The following description of lap belt guide **254** shown in FIG. **15** is equally applicable to lap belt guide **255**. Lap belt guide **254** is a monolithic component formed to include apertures **266, 267** sized to receive lap belt **120** and a belt-receiver slot **270**. Apertures **266, 267** illustratively provide for mating with corresponding lap belt straps **264, 265** and provide adjustment means for allowing a caregiver to vary an effective length of lap belt straps **264, 65** between the compliant contoured seat pad **212** and the corresponding lap belt guides **254, 255**. Belt-receiver slot **270** is accessible through a diagonal belt-travel slot **272** communicating with the belt-receiver slot **270** to allow a child to slide lap belt **120** into the belt-receiver slot **270**.

Compliant contoured seat pad **212** is a low-profile component that blends in with seat bottom **114** of passenger seat **112**. Compliant contoured seat pad **212** is made of a solid foam material core **280** and is covered with a sturdy fabric material cover **285** in an illustrative embodiment of the present disclosure. This solid foam design is shaped with contours to fit a child that is not quite tall enough to fit properly in a passenger-restraint harness system **170** while seated on a passenger seat **112**. This contour (as shown, for example, in FIGS. **13 and 14**) prevents slouching which might otherwise contribute to raising the lap belt from the thigh region to the abdominal region of a seated child.

11

Adjustable lap belt guides **254, 255** included in tethers **214, 215** cooperate to help place lap belt **120** in a proper position on the thigh region of a child seated on compliant contoured seat pad **212**. The lap belt guides **254, 255** are permanently held to the compliant contoured seat pad **212** with webbing such as guide-support straps **264, 265**. Belt-positioning booster seat **210** avoids reliance on armrests or inflation of inflatable features to position the lap belt on a seated child.

The invention claimed is:

**1.** A belt-positioning booster seat for use with a passenger seat having a seat bottom and a seat back arranged to extend upwardly from the seat bottom, the belt-positioning booster seat comprising

a portable contoured seat pad including a low-elevation buttocks-support portion adapted to be positioned adjacent to the seat back of a passenger seat and a high-elevation leg-support portion adapted to be spaced apart from the seat back of the passenger seat by the rear low-elevation buttocks-support portion,

a left lap belt-positioning tether coupled to the portable contoured seat pad and arranged to extend from a left side of the portable contoured seat pad, the left lap belt-positioning tether configured to receive a vehicle lap belt, and

a right lap belt-positioning tether coupled to the portable contoured seat pad and arranged to extend from a right side of the portable contoured seat pad, the right lap belt-positioning tether configured to receive a vehicle lap belt,

wherein the high-elevation leg-support portion of the portable contoured seat pad is arranged to extend about half the length of the portable contoured seat pad from a front of the portable contoured seat pad toward a back of the portable contoured seat pad, the front high-elevation leg-support portion includes a laterally extending peak and a forward tailbone-locator incline, the laterally extending peak has a greater height than the low-elevation buttocks-support portion, the laterally extending peak has a curved convex top surface, and the forward tailbone-locator incline arranged to slope downwardly from the laterally extending peak to the low-elevation buttocks-support portion to provide positioning means for locating a tailbone of a child rearward of the high-elevation leg-support portion over the low-elevation buttocks-support portion and for angling thighs of the child upward from the low-elevation buttocks-support portion causing the thighs of the child to form a slightly obtuse angle with lower legs of the child when the child is seated on the booster seat so that the child is encouraged to sit up straight along the seat back of the passenger seat and so that the lower legs of the child are guided along a smooth transition toward a front of the seat bottom included in the passenger seat underlying the booster seat.

**2.** The booster seat of claim **1**, wherein the rear low-elevation buttocks-support portion is arranged to extend about half the length of the portable contoured seat pad from the back of the portable contoured seat pad toward the front of the portable contoured seat pad, the rear low-elevation buttocks-support portion includes an aft laterally extending peak, a tailbone support, and an aft tailbone-locator incline is arranged to slope downwardly from the aft laterally extending peak to the tailbone support to provide positioning means for locating a tailbone of a child forward of the back of the portable contoured seat pad over the tailbone support of the rear low-elevation buttocks-support portion when the child is

12

seated on the booster seat so that the child is encouraged to sit up straight along the seat back of the passenger seat.

**3.** The booster seat of claim **2**, wherein the curved convex top surface of the laterally extending peak forms a top elevation of the portable contoured seat pad and has a curve radius of about 37.5 millimeters at the top elevation of the portable contoured seat pad.

**4.** The booster seat of claim **2**, wherein the forward tailbone-locator incline of the high-elevation leg-support portion extends upwardly from the tailbone support of the low-elevation buttocks-support portion to the laterally extending peak at a first angle defined between a generally flat plane tangent to the tailbone support of the low-elevation buttocks-support portion and the top of the forward tailbone-locator incline.

**5.** The booster seat of claim **4**, wherein the aft tailbone-locator incline of the low-elevation buttocks-support portion extends upwardly from the tailbone support of the low-elevation buttocks-support portion at a second angle, smaller than the first angle, defined between the generally flat plane tangent to the tailbone support of the low-elevation buttocks-support portion and the top of the aft tailbone-locator incline.

**6.** The booster seat of claim **5**, wherein the first angle is about 9 degrees and the second angle is about 5.5 degrees.

**7.** The booster seat of claim **4**, wherein the portable contoured seat pad is formed from a plurality of shaped foam layers received in a cover and the shaped foam layers are sized to define the laterally extending peak, the forward tailbone-locator incline, the tailbone support, and the aft tailbone-locator incline of the portable contoured seat pad.

**8.** The booster seat of claim **1**, wherein the portable contoured seat pad includes a left ear that extends from a left side of the low-elevation buttocks-support portion and a right ear that extends from a right side of the low-elevation buttocks-support portion, the left lap belt-positioning tether is secured to the left ear, and the right lap belt-positioning tether is secured to the right ear.

**9.** The booster seat of claim **8**, wherein the left ear and the right ear are thinner than the low-elevation buttocks-support portion so that stitches of thread used to secure the left lap belt-positioning tether to the left ear can pass through the left ear and the left lap belt-positioning tether and stitches of thread used to secure the right lap belt-positioning tether to the right ear can pass through the right ear and the right lap belt-positioning tether.

**10.** The booster seat of claim **9**, wherein the low-elevation buttocks-support portion and the high-elevation leg-support portion included in the portable contoured seat pad are formed from a plurality of shaped foam layers received in a cover and the left ear and the right ear are formed from portions of the cover that do not receive a shaped foam layer.

**11.** The booster seat of claim **9**, wherein the left lap belt-positioning tether includes a left lap belt guide adapted to receive a lap belt and a first portion of a lap belt strap, the right lap belt-positioning tether includes a right lap belt guide adapted to receive a lap belt and a second portion of the lap belt strap, and the lap belt strap extends along an underside of the portable contoured seat pad from the left side to the right side of the portable contoured seat pad to provide a handle that can be grasped by a caregiver moving the booster seat.

**12.** A booster seat comprising

a portable contoured seat pad including a rear low-elevation buttocks-support portion adapted to underlie buttocks of a child seated on the booster seat and a front high-elevation leg-support portion adapted to underlie thighs of a child seated on the booster seat,

a left lap belt-positioning tether coupled to the portable contoured seat pad and arranged to extend from a left

13

side of the portable contoured seat pad and configured to retain a vehicle lap belt in a selected position relative to the portable contoured seat pad, and right lap belt-positioning tether coupled to the portable contoured seat pad and arranged to extend from a right side of the portable contoured seat pad and configured to retain a vehicle lap belt in a selected position relative to the portable contoured seat pad, wherein the rear low-elevation buttocks-support portion is arranged to extend about half the length of the portable contoured seat pad from a back of the portable contoured seat pad toward a front of the portable contoured seat pad, the rear low-elevation buttocks-support portion includes a aft tailbone-locator incline and a tailbone support, and the aft tailbone-locator incline is arranged to extend upwardly from the tailbone support toward the back of the portable contoured seat pad forming a first angle defined between a generally flat plane tangent to the tailbone support of the low-elevation buttocks-support portion and a top of the aft tailbone-locator incline to locate a tailbone of a child forward of the aft tailbone-locator incline over the tailbone support of the rear low-elevation buttocks-support portion when the child is seated on the portable contoured seat pad, and the high-elevation leg-support portion is arranged to extend about half the length of the portable contoured seat pad from the front of the portable contoured seat pad toward the back of the portable contoured seat pad, the high-elevation leg-support portion includes a laterally extending peak and a forward tailbone-locator incline, the laterally extending peak has a curved convex top surface that extends along the front of the portable contoured seat pad, and the forward tailbone-locator incline is arranged to extend downwardly from the laterally extending peak to the tailbone support of the rear low-elevation buttocks-support portion forming a second angle defined between a generally flat plane tangent to the tailbone support of the low-elevation buttocks-support portion and a top of the forward tailbone-locator incline, the second angle greater than the first angle, to locate the tailbone of the child rearward of the forward inclined section over the tailbone support of the rear low-elevation buttocks-support portion when the child is seated on the portable contoured seat pad.

13. The booster seat of claim 12, wherein the curved convex top surface of the laterally extending peak forms a top elevation of the portable contoured seat pad and has a radius of about 37.5 millimeters to cause the thighs of the child form a slightly obtuse angle with lower legs of the child when the child is seated on the booster seat.

14. The booster seat of claim 12, wherein the width of the rear low-elevation buttocks-support portion is smaller than the width of the high-elevation leg-support portion so that thighs of a child seated on the booster seat can be splayed apart to the width of the high-elevation leg-support portion and remain supported on the high-elevation leg-support portion.

15. The booster seat of claim 14, wherein the portable contoured seat pad is formed from a plurality of shaped foam layers received in a cover and the shaped foam layers are sized to define the laterally extending peak, the forward tailbone-locator incline, the tailbone support, and the aft tailbone-locator incline of the portable contoured seat pad.

16. The booster seat of claim 15, wherein the portable contoured seat pad includes a left ear that extends from a left side of the low-elevation buttocks-support portion that is thinner than the low-elevation buttocks-support portion and a

14

right ear thinner than the low-elevation buttocks-support portion that extends from a right side of the low-elevation buttocks-support portion, the left lap belt-positioning tether is secured to the left ear, and the right lap belt-positioning tether is secured to the right ear.

17. The booster seat of claim 16, wherein the left ear and the right ear are formed from portions of the cover that do not receive a shaped foam layer, stitches of thread extend through the left ear and the left lap belt-positioning tether to secure the left lap belt-positioning tether to the left ear, and stitches of thread extend through the right ear and the right lap belt-positioning tether to secure the right lap belt-positioning tether to the right ear.

18. A booster seat comprising

a portable contoured seat pad including a body constructed from a plurality of shaped layers made from a foam material received in a cover and the shaped foam layers are sized to define a contoured top side of the portable contoured seat pad forming a low-elevation buttocks-support portion adapted to be positioned adjacent to the seat back of a passenger seat and a high-elevation leg-support portion adapted to be spaced apart from the seat back of the passenger seat by the rear low-elevation buttocks-support portion, wherein there is greater number of layers of foam material in the high-elevation leg-support portion than in the low-elevation buttocks-support portion,

a left lap belt-positioning tether coupled to the portable contoured seat pad and arranged to extend outwardly from a left side of the portable contoured seat pad, the left lap belt-positioning tether configured to receive a lap belt, and a right lap belt-positioning tether coupled to the portable contoured seat pad and arranged to extend outwardly from a right side of the portable contoured seat pad, the right lap belt-positioning tether configured to receive a lap belt.

19. The booster seat of claim 18, wherein the portable contoured seat pad includes a left ear that extends from a left side of the body that is thinner than the body and a right ear thinner than the body that extends from a right side of the body, the left lap belt-positioning tether is secured to the left ear, and the right lap belt-positioning tether is secured to the right ear.

20. The booster seat of claim 19, wherein the left ear and the right ear are formed from portions of the cover that do not receive a shaped foam layer, stitches of thread extend through the left ear and the left lap belt-positioning tether to secure the left lap belt-positioning tether to the left ear, and stitches of thread extend through the right ear and the right lap belt-positioning tether to secure the right lap belt-positioning tether to the right ear.

21. The booster seat of claim 20, wherein the left lap belt-positioning tether includes a left lap belt guide adapted to receive a lap belt and a left lap belt strap that is secured to the left ear by stitches of thread and the right lap belt-positioning tether includes a right lap belt guide adapted to receive a lap belt and a right lap belt strap secured to the right ear by stitches of thread.

22. The booster seat of claim 18, wherein the cover is made from a foam material so that the entire portable contoured seat pad is constructed from foam materials without hardened components.

23. The booster seat of claim 22, wherein the cover is formed to define a plurality of slip reducer feet that extend downwardly from an underside the body included in the portable contoured seat pad.

24. The booster seat of claim 18, wherein each of the left lap belt-positioning tether and the right lap belt-positioning tether includes a lap belt guide configured to receive and retain the lap belt and a lap belt strap that extends outwardly from the portable contoured seat pad and the lap belt guides of the left lap belt-positioning tether and of the right lap belt-positioning tether coupled to a corresponding lap belt strap to move along the corresponding lap belt strap toward and away from the portable contoured seat pad.

\* \* \* \* \*