

(19) World Intellectual Property Organization
International Bureau



(43) International Publication Date
14 October 2004 (14.10.2004)

PCT

(10) International Publication Number
WO 2004/087006 A2

- (51) International Patent Classification⁷: **A61F**
- (21) International Application Number: PCT/US2004/008909
- (22) International Filing Date: 23 March 2004 (23.03.2004)
- (25) Filing Language: English
- (26) Publication Language: English
- (30) Priority Data:
 - 60/458,323 26 March 2003 (26.03.2003) US
 - 60/462,219 10 April 2003 (10.04.2003) US
 - 10/746,452 24 December 2003 (24.12.2003) US
 - 10/745,778 24 December 2003 (24.12.2003) US
 - 10/746,455 24 December 2003 (24.12.2003) US
 - 10/792,684 2 March 2004 (02.03.2004) US

- (72) Inventors; and
- (75) Inventors/Applicants (for US only): **NIKOLCHEV, Julian** [US/US]; 251 Duranzo Way, Portola Valley, CA 94028 (US). **TON, Dai T.** [US/US]; 1514 Mt. Diablo Avenue, Milpitas, CA 95035 (US). **GEORGE, William R.** [US/US]; 435 Oxford Way, Santa Cruz, CA 95060 (US). **DE BEER, Nick** [US/US]; P.O. Box 371373, Montara, CA 94037 (US).

- (74) Agent: **LASALLE, Carol**; Bozicevic, Field & Francis LLP, 1900 University Avenue, Suite 200, East Palo Alto, CA 94303 (US).

- (81) Designated States (unless otherwise indicated, for every kind of national protection available): AE, AG, AL, AM, AT, AU, AZ, BA, BB, BG, BR, BW, BY, BZ, CA, CH, CN, CO, CR, CU, CZ, DE, DK, DM, DZ, EC, EE, EG, ES, FI, GB, GD, GE, GH, GM, HR, HU, ID, IL, IN, IS, JP, KE, KG, KP, KR, KZ, LC, LK, LR, LS, LT, LU, LV, MA, MD, MG, MK, MN, MW, MX, MZ, NA, NI, NO, NZ, OM, PG,

- (71) Applicant (for all designated States except US): **CARDIOMIND, INC.** [US/US]; Suite 111, 1235 Pear Avenue, Mountain View, CA 94304 (US).

[Continued on next page]

(54) Title: IMPLANT DELIVERY TECHNOLOGIES

(57) Abstract: Medical devices (100) and methods for delivery or implantation of prostheses (106) within hollow body organs and vessels (600) or other luminal anatomy are disclosed. The subject technologies may be used in the treatment of atherosclerosis in stenting procedures or for other purposes.

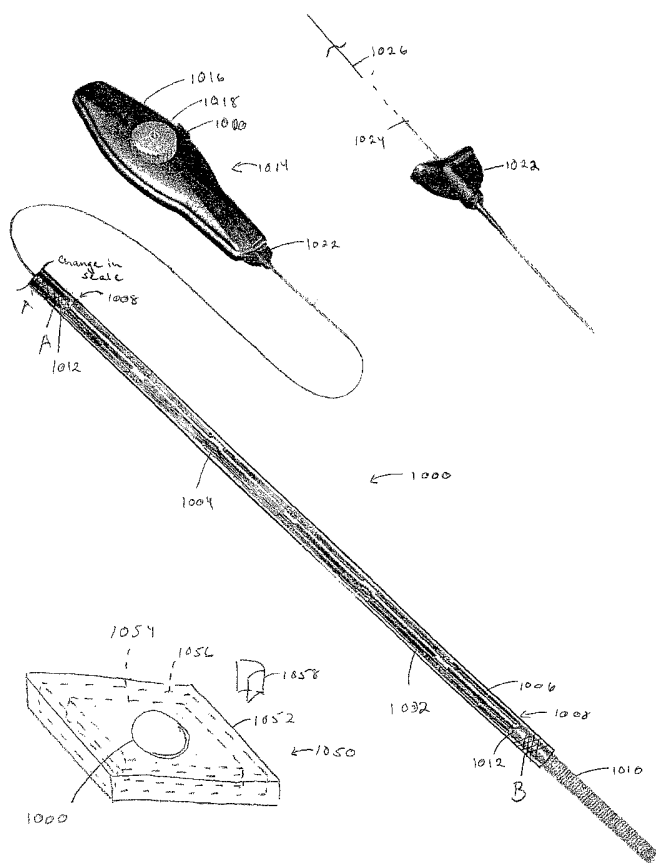

WO 2004/087006 A2



PH, PL, PT, RO, RU, SC, SD, SE, SG, SK, SL, SY, TJ, TM,
TN, TR, TT, TZ, UA, UG, US, UZ, VC, VN, YU, ZA, ZM,
ZW.

TR), OAPI (BF, BJ, CF, CG, CI, CM, GA, GN, GQ, GW,
ML, MR, NE, SN, TD, TG).

(84) Designated States (*unless otherwise indicated, for every kind of regional protection available*): ARIPO (BW, GH, GM, KE, LS, MW, MZ, SD, SL, SZ, TZ, UG, ZM, ZW), Eurasian (AM, AZ, BY, KG, KZ, MD, RU, TJ, TM), European (AT, BE, BG, CH, CY, CZ, DE, DK, EE, ES, FI, FR, GB, GR, HU, IE, IT, LU, MC, NL, PL, PT, RO, SE, SI, SK,

Published:

— *without international search report and to be republished upon receipt of that report*

For two-letter codes and other abbreviations, refer to the "Guidance Notes on Codes and Abbreviations" appearing at the beginning of each regular issue of the PCT Gazette.

IMPLANT DELIVERY TECHNOLOGIES

CROSS REFERENCE TO RELATED APPLICATIONS

[0001] Priority to or the benefit of U.S. Provisional Patent Applications IMPLANT DELIVERY DEVICE (Serial No. 60/458,323), filed March 26, 2003 and IMPLANT DELIVERY DEVICE II (Serial No. 60/462,219), filed April 10, 2003 and U.S. Patent Applications IMPLANT DELIVERY TECHNOLOGIES (Serial No. 10/745,778), MULTIPLE JOINT IMPLANT DELIVERY SYSTEMS FOR SEQUENTIALLY-CONTROLLED IMPLANT DEPLOYMENT (Serial No. 10/746,452), and BALLOON CATHETER LUMEN BASED STENT DELIVERY SYSTEMS (Serial No. 10/746,455), each filed December 24, 2003, and SLIDING RESTRAINT STENT DELIVERY SYSTEMS (Serial No. 10/792,684), filed March 2, 2004 is claimed. Furthermore, each of the above-referenced applications is hereby incorporated by reference herein in its entirety.

FIELD OF THE INVENTION

[0002] The present invention relates generally to medical device and methods. More particularly, it relates to delivery systems for implanting prostheses within hollow body organs and vessels or other luminal anatomy.

BACKGROUND OF THE INVENTION

[0003] Implants such as stents and occlusive coils have been used in patients for a wide variety of reasons. For instance, stents are often used to treat arterial stenosis secondary to atherosclerosis. Various stent designs have been developed and used clinically, but self-expandable and balloon-expandable stent systems and their related deployment techniques are now predominant. Examples of self-expandable stents currently in use are WALLSTENT® stents and Radius stents (Boston Scientific). A commonly used balloon-expandable stent is the Cypher® stent (Cordis Corporation). Additional self-expanding stent background is presented in: "An Overview of Superelastic Stent Design," Min. Invas Ther & Allied Technol 2002: 9(3/4) 235-246, "A Survey of Stent Designs," Min. Invas Ther & Allied Technol 2002: 11(4) 137-147, and "Coronary Artery Stents: Design and Biologic Considerations," Cardiology Special Edition, 2003: 9(2) 9-14, "Clinical and Angiographic Efficacy of a Self-Expanding Stent" Am Heart J 2003: 145(5) 868-874.

[0004] Typically, after balloon angioplasty has been performed, either a self-expandable or balloon-expandable stent is advanced over a guidewire and positioned at the target site. A protective sheath or membrane is then retracted proximally to allow expansion of a self-

expanding stent. Alternatively, a delivery balloon may be inflated, thereby expanding the stent.

[0005] Despite improvements in delivery systems, balloon design, and stent design, these over-the-guidewire and/or sheathed self-expanding stent deployment systems still have their limitations. For instance, sheathed stents tend to move forward when the sheath is pulled back, deploying them imprecisely. The sheathed design also requires that the stent delivery system be larger in diameter and less flexible. Furthermore, for sheathed systems, the interventional procedure may only proceed if the vessel of interest is of sufficiently large diameter to allow sheath placement to avoid significant damage to the luminal surface of the vessel. Moreover, balloon-expandable stents, by virtue of a large diameter and relative inflexibility, are often unable to reach distal vasculature. For both self-expandable and balloon-expandable stent deployment systems, repositioning or step-wise release of the stent are usually not available features. Similarly, occlusive coil placement systems such as systems that deliver detachable platinum coils and GDC® coils also generally do not contain repositionable or step-wise release features.

[0006] Consequently, a smaller diameter (lower profile), repositionable implant deployment device that releases an implant into, or upon, a body region in a more precise, continuous or step-wise fashion, without the use of a sheath or balloon would provide significant benefit to patients with various medical conditions.

SUMMARY OF THE INVENTION

[0007] The present invention is a low profile implant delivery device that may be deployed without a sheath, and is designed to release portions of implants simultaneously or sequentially. The invention relates to devices and methods for placing one or more implants such as helical scaffolds or occlusive members into tubular organs or open regions of the body. The implants may be of types that maintain patency of an open anatomical structure, occlude a selected volume, isolate a region, or collect other occlusive members at a site. The invention optionally provides an atraumatic, low profile device for the delivery of one or more implants into tubular organs or open regions of the body. The implant delivery device may simultaneously or independently (e.g., sequentially) release portions of the implant, e.g., the proximal and distal ends of the implant. This independent release feature allows better implant positioning at the target site. Included in the description are devices and methods for deploying the various implants, typically without a sheath, in a serial fashion, and with high

adjustability. However, a number of highly space-efficient or otherwise advantageous sheath-based delivery systems are disclosed.

[0008] In one variation, the implant delivery device includes a noninflatable, elongate delivery guide member having a distal end and configuration that allows it to direct at least one implant having an exterior and interior surface to an anatomical treatment site by manipulation by a user. The at least one implant has a delivery diameter prior to its release, is located proximally of the distal end of the delivery guide member prior to release, and has at least one releasable joint configured to maintain at least a section of the at least one implant at the delivery diameter until release of the at least one releasable joint. The delivery guide member sections that are proximal and distal to the at least one implant also have delivery diameters. These guide member delivery diameters may be substantially equal to the at least one implant delivery diameter prior to implant release.

[0009] The implant may be a helical scaffold, e.g., a stent, in particular, a self-expandable stent, or it may be an occlusive coil. The implant may be symmetric or asymmetric. In some instances, the implant delivers a therapeutic agent.

[0010] The delivery guide member may include a wire and/or a tubular member having a lumen. If desired, a radioopaque marker may be included on the delivery guide to aid with its placement. When designed to include a tubular member, it co-axially surrounds at least a portion of the delivery guide, and works as a tubular actuator configured to release at least one releasable joint upon distal axial movement along the delivery guide member.

[0011] In another variation, the implant delivery device includes an actuator slidably located at least partially within the delivery guide member and is configured to mechanically release at least one releasable joint upon axial movement of the actuator within the delivery guide member. In other variations, the actuator may also release at least one releasable joint upon rotational movement of the actuator, upon the application of fluid pressure in the delivery guide member lumen, or upon application of a suitable DC current to the at least one releasable joint. Release of the releasable joints using any one of the release mechanisms described above may be sequential, if precise positioning is required, or may be simultaneous.

[0012] Other variations of the invention include sheath based delivery systems. In one of these, the core member carrying the stent further included an atraumatic tip. In another, the sheath restraining the stent takes the form of a balloon catheter. In addition, both features may be combined. Additional variations of the invention employ non-active members (in the forms

of hooks, grippers, etc.) adapted to interface with a radially expandable implant to pull and/or twist the member in order to hold it in a collapsed configuration.

[0013] The implant delivery device may be included in a system for implant delivery which further employs one or more embolic filters at either the proximal or distal section of the delivery guide, or at both the proximal and distal sections of the delivery guide. It may be provided in a kit packaged for sale, together with instructions.

[0014] The system may be used for implant delivery into lumens of tubular organs including, but not limited to, blood vessels (including intracranial vessels, large vessels, peripheral vessels, adjacent aneurysms, arteriovenous malformations, arteriovenous fistulas), ureters, bile ducts, fallopian tubes, cardiac chambers, ducts such as bile ducts and mammary ducts, large and small airways, and hollow organs, e.g., stomach, intestines, and bladder. The implant may be of a design that is of a size that is smaller during delivery and larger after implantation. The design may be used to provide or to maintain patency in an open region of an anatomical structure, or to occlude a site, or to isolate a region (e.g., to close an aneurysm by blocking the aneurysm opening or neck by placement in an adjacent anatomical structure such as an artery or gastrointestinal tubular member), or to corral or collect a number of occlusive devices (e.g., coils or hydratable polymeric noodles) or compositions at a site to be occluded or supported. In another variation, the implant is located in a gap between proximal and distal sections of the delivery guide member. The system may also be employed for implant delivery into solid organs or tissues including, but not limited to, skin, muscle, fat, brain, liver, kidneys, spleen, and benign and malignant tumors. Oftentimes, the implant is delivered to a target site in a blood vessel lumen.

[0015] In a general aspect, the system is a guidewire-less implant delivery system that includes a noninflatable, elongate delivery guide member having a proximal end and a distal end. The guide member is configured to direct at least one implant having an exterior and interior surface to an anatomical treatment site by manipulation by a user. The at least one implant has a delivery diameter prior to release of the at least one implant and is located proximally of the distal end of the delivery guide member prior to release. The at least one releasable joint is configured to maintain at least a section of the at least one implant at the delivery diameter until release of the at least one releasable joint. The guidewire-less system also has a flexibility and remote directability (e.g. torquability) such that a user may direct the distal end of the guide member into, and introduce, the at least one implant into a coronary artery solely by manipulation of the delivery guide member from its proximal end.

[0016] The present invention includes systems comprising any combination of the features described herein. Methodology described in association with the devices disclosed also forms part of the invention. Such methodology may include that associated with completing an angioplasty, bridging an aneurysm, deploying radially-expandable anchors for pacing leads or an embolic filter, or placement of a prosthesis within neurovasculature, an organ selected from the kidney and liver, within reproductive anatomy such as selected vasdeferens and fallopian tubes or other applications.

BRIEF DESCRIPTION OF THE DRAWINGS

[0001] Each of the figures diagrammatically illustrates aspects of the invention. Of these:

Figure 1A is a side view of an implant delivery device with a partial cross-section of the distal section of the delivery guide;

Figure 1B is a cross-sectional view of the delivery guide and implant taken at line 1B-1B in Figure 1A;

Figure 2 is a side view of an implant delivery device having a tubular member (actuator) attached to the proximal implant end with a partial cross-section of the distal section of the delivery guide;

Figure 3A is a side view of the implant in Figure 2 being expanded by distally moving the tubular member towards the distal section of the delivery guide;

Figure 3B is a longitudinal cross-sectional view of a distal implant release mechanism;

Figures 3C₁ and 3C₂ are longitudinal cross-sectional views of an implant delivery device having a mechanical release mechanism for deploying one end of an implant;

Figures 3D₁-3D₃ are longitudinal cross-sectional views of an implant delivery device having a mechanical release mechanism for independently releasing the implant ends;

Figures 3E₁-3E₄ are longitudinal cross-sectional views of an implant delivery device having a hydraulic release mechanism for independently releasing the implant ends;

Figures 3F₁-3F₂ are longitudinal cross-sectional views of a variation of the hydraulic release mechanism described in 3E₁-3E₄;

Figures 3G₁-3G₃ are longitudinal cross-sectional views of an implant delivery device having a mechanical release mechanism according to another variation of the invention;

Figure 4 is a longitudinal cross-sectional view of an implant delivery device having a mechanical release mechanism according to yet another variation of the invention;

Figures 5A-5C are longitudinal cross-sectional views of an implant delivery device having an electrolytic implant release mechanism;

Figure 5D shows a longitudinal cross-sectional view of an implant delivery device having an electrolytic release mechanism according to another variation of the invention;

Figure 5E shows a longitudinal cross-sectional view of an implant delivery device having a thermal release mechanism according to one variation of the invention;

Figures 6A-6D show the general method for serially releasing an implant at a target site;

Figure 7 shows a heart in which its vessels may be the subject of one or more angioplasty and/or stenting procedures as described in connection with a more specific method of the invention;

Figure 8 shows an expanded stent cut pattern as may be used in producing a stent for use in the present invention;

Figures 9A-9L illustrate stent deployment methodology to be carried out in connection with an stenting and/or angioplasty procedure;

Fig. 10 provides an overview of a system according to the present invention in connection with optional packaging;

Figs. 11A-11C show side views of another variation of the invention, detailing constituent parts and distal end of a delivery system, respectively;

Figs. 12A and 12B show side views of another implant delivery system, in unloaded and loaded configurations respectively; Figs. 13A and 13B show another type of delivery system in the same manner; and

Fig. 14A is a partial sectional view of the end of a stent and corresponding delivery guide interface features; Fig. 14B is an end view of the members shown in Fig. 14A.

Variation of the invention from the embodiments pictured is, of course, contemplated.

DETAILED DESCRIPTION OF THE INVENTION

[0017] Described here are devices, systems, and methods for delivering implants into both open and solid regions of the body. The term "region" as used herein refers to luminal structures as well as solid organs and solid tissues of the body, whether in their diseased or nondiseased state. Examples of luminal structures include, but are not limited to, blood vessels, arteriovenous malformations, aneurysms, arteriovenous fistulas, cardiac chambers, ducts such as bile ducts and mammary ducts, fallopian tubes, ureters, large and small airways, and hollow organs, e.g., stomach, intestines, and bladder. Solid organs or tissues include, but

are not limited to, skin, muscle, fat, brain, liver, kidneys, spleen, and benign and malignant tumors.

[0018] The device assembly generally includes an elongate, perhaps solid delivery guide, an implant, and one or more implant release mechanisms. Guidewire-less systems are used to deliver the one or more implants. By "guidewire-less" it is meant that the system does not require a guiding device of a diameter less than that of the system to reach a chosen implantation site. Instead, the guidewire-less system is flexible and remotely directable, the remote directability being such that a user may direct the distal end of the guide member into, and introduce (e.g. by torquing the member), the at least one implant into a coronary artery solely by manipulation of the delivery guide member from its proximal end.

Delivery Guide

[0019] The delivery guide is elongate and has a comparatively small effective diameter. It has the function of permitting delivery of the implant to a selected site and supporting the implant in a collapsed form during positioning and implantation. The delivery guide is usually noninflatable. It may also be solid, or may have a lumen extending therethrough, depending on such factors as the degree of flexibility required, type of associated release mechanism, the constituent material, and the like. The tip of the delivery guide may be tapered and/or straight, curved, or j-shaped, depending on factors such as physician preference, the anatomy of the tubular organ or region of interest, degree of stiffness required, and the like. The delivery guide may or may not include an outer spring coil, for, e.g., fluoroscopic visualization.

[0020] The delivery guide may be made from any biocompatible material including, but not limited to, stainless steel and any of its alloys; titanium alloys, e.g., nickel-titanium alloys; other shape memory alloys; tantalum; polymers, e.g., polyethylene and copolymers thereof, polyethylene terephthalate or copolymers thereof, nylon, silicone, polyurethanes, fluoropolymers, poly (vinylchloride), and combinations thereof. The diameter of the delivery guide may usually be about 0.013 cm to about 0.130 cm (about 0.005 inches to about 0.05 inches), more usually about 0.013 cm to about 0.076 cm (about 0.005 inches to about 0.03 inches), and more usually still about 0.015 cm to about 0.030 cm (about 0.006 inches to about 0.012 inches). In a preferred variation, the diameter of the delivery guide is approximately about 0.020 cm (about 0.008 inches).

[0021] A lubricious coating may be placed on the delivery guide if desired to facilitate advancement of the delivery guide. The lubricious coating typically will include hydrophilic polymers such as polyvinylpyrrolidone-based compositions, fluoropolymers such as

tetrafluoroethylene, or silicones. In one variation, the lubricious coating may constitute a hydrophilic gel. Furthermore, the delivery guide may include one or more radioopaque markers that indicates the location of the distal section of the delivery guide upon radiographic imaging. Usually, the marker will be detected by fluoroscopy.

Implants

- [0022] The implant itself may be of a shape tailored to achieve a specific purpose. As noted elsewhere, if the purpose of the implant is to provide or to maintain patency of an anatomical structure such as an artery or duct, the implant shape after implantation is itself tubular. The shape may be symmetric or asymmetric, as the purpose dictates.
- [0023] Other shapes, including cage structures, may be used to provide patency to vessels or to act as collecting or coralling structures for occlusive members or materials.
- [0024] If the purpose or task is to occlude a lumen or open region, the implant may have the form of an occlusive coil that remains helical or assumes a random orientation after deployment.
- [0025] In one variation, the implant for placement into a luminal structure is a helical scaffold, e.g., a stent, but any scaffold shape that maintains patency of a lumen may be used. The stents are typically self-expanding stents, such as described in U.S. 4,768,507 to Fishell et al., U.S. 4,990,155 to Wilkoff et al., and U.S. 4,553,545 to Maass et al. In another variation, the implant is an occlusive member, e.g., an occlusive coil, such as described in U.S. 5,334,210 to Gianturco and U.S. 5,382,259 to Phelps et al.
- [0026] The interior and exterior surfaces of the implant may be designed to prevent the activation of pathological processes during or after implant deployment. For example, in the case of a vascular stent, the exterior stent surface may be formed to be smooth to decrease the likelihood of intimal damage upon stent release (which would trigger the inflammatory process and attract atheromatous plaque-forming cells). The interior stent surface may also be smooth to minimize turbulent flow through the stent and decrease the risk of stent thrombosis.
- [0027] Important physical properties of the implant to consider include, but are not limited to: length, (stent) diameter in the expanded state, degree of flexibility and lateral stiffness, and the like. These physical properties will be modified to account for such factors as lumen diameter, length of any stenosis, type of luminal structure, or solid organ or tissue involved.
- [0028] Metals such as stainless steel and tantalum, or metal alloys such as alloys of nickel and titanium, specifically including superelastic alloys such as NITINOL or Elgiloy which are commonly used by those of skill in the art, may be used to form the implants. However, the

implants may also be made from biodegradable polymers, e.g., copolymers of lactic and glycolic acid, or nonbiodegradable polymers, e.g., copolymers of ethylene and vinyl acetate.

[0029] The implants may also include a therapeutic agent. Examples of therapeutic agents that may be used in the implants include, but are not limited to, antibiotics, anticoagulants, antifungal agents, anti-inflammatory agents, antineoplastic agents, antithrombotic agents, endothelialization promoting agents, free radical scavengers, immunosuppressive agents, thrombolytic agents, and any combination thereof. If the implant is a stent, an antithrombotic agent is preferably included.

[0030] Examples of selective antithrombotic agents include acetylsalicylic acid, argatroban, cilostazol, copidogrel, cloricromen, dalteparin, daltroban, defibrotide, dipyridamole, enoxaparin, epoprostenol, indobufen, iloprost, integrilin, isbogrel, lamifiban, lamoparan, nadroparin, ozagrel, picotamide, plafibrade, reviparin sodium, ridogrel, sulfinpyrazone, taprostene, ticlopidine, tinzaparin, tirofiban, triflusal, and any of their derivatives.

[0031] The therapeutic agent may be coated onto the implant, mixed with a biodegradable polymer or other suitable temporary carrier and then coated onto the implant, or, when the implant is made from a polymeric material, dispersed throughout the polymer.

[0032] The implant may include a radioactive material. The radioactive material may be selected on the basis of its use. For instance, the material may be included in an implant where the implant is in the form of a stent that is to be situated over a vascular stenosis. The radioactivity lowers the incidence of re-stenosis. Additionally, the radioactivity may serve the function of a tracer, to allow detection of the location of the implant during the procedure or anytime thereafter. Suitable radioactive tracers include isotopes of gallium, iodine, technetium, and thallium.

Release Mechanism

[0033] In one variation of the generic implant delivery system, as shown in Figure 1A, the implant delivery system includes a delivery guide 100. Delivery guide 100 has a proximal section 102 and a distal section 104. An implant, in this case depicted as a stent 106, surrounds a portion of the distal section 104 of the delivery guide, and is releasably attached to the distal section 104 of the delivery guide. The implant 106, as shown in Figure 1B, is concentrically adjacent to the delivery guide 100. Although the implant (106) is shown as a stent in Figure 1A and 1B, depiction in this fashion is solely for the illustrative purpose of indicating the siting of the implant 106 on the delivery guide 100 with the distal and proximal implant release

mechanism (109, 111). Various implant release mechanisms or structures are discussed in greater detail below.

[0034] Implant 106 is shown to be directly attached to, is contiguous to, the delivery guide 100 at the proximal end 108 of the implant and distal end 110 of the implant. In the system shown in Figure 1A, implant 106 may be secured to the delivery guide 100 by such generic controllably releasable mechanisms as mechanical, thermal, hydraulic, and electrolytic mechanisms, or a combination thereof. Examples of these release mechanisms will be discussed below.

[0035] Consequently, release of the implant 106 from the delivery guide 100 may be achieved through a mechanical detachment process involving, e.g., twisting of the delivery guide, such as described by Amplatz in U.S. 6,468,301, or translational movement of the delivery guide in relation to the implant. Implant release may also be achieved using a thermally detachable joint, such as described in U.S. 5,108,407 to Geremia et al., an electrolytic detachable joint, such as described in U.S. 5,122,136 and U.S. 5,354,295, both to Guglielmi et al., or a combination thereof.

[0036] In another variation, and as shown in Figure 2, the system includes a tubular member 200 co-axially mounted on a delivery guide 202. Tubular member 200 may form a component of the delivery guide 202 that cooperates with one or more of the releasable mentioned joints on the implant (209, 211) to release those joints (and therefore, release the implant 204) upon application of a releasing movement, axial or twisting. An implant, e.g., a stent 204, is mounted on a distal section 206 of the delivery guide and the distal end 208 of the tubular member is attached to the proximal end 210 of the stent. The distal end 212 of the stent is attached using a releasable joint 211 to the distal section 206 of the delivery guide 202.

[0037] As mentioned above, tubular member mounted coaxially about the delivery guide may be used, that slides axially about that delivery guide, as an actuator to release the implant. The outer tubular member may also be used to pre-position the implant. For instance, prior to release, the outer tubular member may be used to expand the implant to therefore obscure its placement, and so to permit adjustment of the placement. Figure 3A shows a stent 300 expanding as tubular member 302 is moved distally on the delivery guide 304, in the direction of the arrow. The stent is then released from the delivery guide. Specifically, the distal end 306 of the stent is released from a distal section 308 of the delivery guide, followed by release of the proximal end 310 of the stent from the distal end 312 of the tubular member. As mentioned above, the stent 300 may be secured to a distal section 308 of the delivery guide by

such mechanisms as lock and key arrangements, biocompatible adhesives, soldering, or a combination thereof. Consequently, stent release may be achieved through a mechanical detachment process, a thermal detachment process (e.g., by heat produced from an exothermic reaction), an electrolytic detachment process, or a combination thereof.

[0038] Figures 3B and 3C show yet another variation of a stent release mechanism. In Figure 3B, brackets 314 may be used to couple the stent 300 to the distal section 308 of the delivery guide. Separation of the stent 306 from the brackets 314, e.g., by one of the detachment processes mentioned above, releases the distal end 306 of the stent from a distal section 308 of the delivery guide, allowing the stent distal end 306 to expand in the tubular organ.

[0039] Controllable release of an end of an implant from the delivery guide may be accomplished using the structure of Figure 3C₁. Brackets 314 couple the stent proximal end 310 to the distal region 312 of the tubular member 313 that forms a portion of the delivery guide. The brackets 314 have a ramped region 316 which are proximally adjacent to an enlarged (and perhaps ball- or barrel-shaped) portion 318 of the delivery guide and bracket arms 320. The delivery guide and stent each have a delivery diameter, and these delivery diameters are substantially equal prior to release of the stent. When the actuator 305 is moved proximally, as shown by the direction of the arrow, the ball-shaped portion 318 forces the ramped regions 316 of the brackets outward from the delivery guide axis, in a radial fashion, causing the bracket arms 320 to be displaced radially outwardly from the proximal end 310 of the stent, thereby releasing the stent proximal end 310.

[0040] Figure 3C₂ shows the results of moving the actuator 305 proximally. The clips (316) have rotated as shown due to the force exerted upon the ramps (317) by the ball (318). The implant (320) has expanded in diameter from that found in its undelivered form.

[0041] Figure 3D₁, shows a delivery system 319 in which the two ends of the implant 321 may be independently deployed by using an actuator 304 having a proximal releasing ball 322 and a distal releasing ball 327. The implant 321 is located in a gap between sections of the delivery guide and are releasably attached to the delivery guide by brackets or clips. The two balls are spaced in such a way that, in the variation shown in Figure 3D₁, the distal ball 327 releases the distal end 331 of implant 321 and the proximal ball 322 then releases the proximal end 329 of implant 321 upon additional proximal movement of actuator 304. This sequence of events is shown in Figs. 3D₁, 3D₂, and 3D₃. The implant 321, is shown to be completely released in Figure 3D₃. In this variation, the implant 321 may be self-expanding, e.g., constructed of a

superelastic alloy such as nitinol or another alloy having high elasticity, e.g., an appropriate stainless steel.

[0042] A structure similar to that shown in Figures 3D₁, 3D₂, and 3D₃ may also be used to deploy an implant using fluid pressure as the releasing impetus.

[0043] Figures 3E₁, 3E₂, 3E₃ and 3E₄ show a hydraulic variation. Shown are the delivery guide 350, having a hollow lumen 352, a self-expanding implant 354 (shown variously as non-expanded (e.g., in a "first form") in Fig. 3E₁, partially expanded in Fig. 3E₂, and fully expanded in Figs. 3E₃ and 3E₄ (e.g., in a "second form")), and an actuator 356 with a sealing member 358 and a radio-opaque member 360.

[0044] The implant 354 (here shown to be a stent or the like) is held to the delivery guide 350 during delivery to the selected treatment site using distal brackets 364 and proximal brackets 362 or clips or the like. The proximal and distal brackets (364, 362) either include regions that cooperate with the fluid in lumen 352 to move upon application of increased pressure in that lumen 352 and release the implant 350 or move in concert with a separate pressure sensitive motion component.

[0045] Figure 3E₁ shows the actuator 356 as the sealing member 358 approaches the various orifices or openings (proximal orifices 366 and distal orifices 368) communicating from the lumen 356 to the hydraulically or fluidly actuatable clips or retaining brackets (proximal brackets 362 and distal brackets 364).

[0046] Included in the description of this variation is a radio-opaque marker 360 on the actuator shaft 356 that allows the user to simply line up that actuator marker 360 with a corresponding radio-opaque marker 370 on the delivery guide 350, increase the pressure in lumen 352 (via syringe, pump, etc.) and deploy the proximal end 371 of implant 354. The interior pressure raises or rotates the proximal clips or brackets 362 and moves them out of contact with the implant 354. Figure 3E₂ shows the movement of the proximal end of implant 354 away from the delivery guide 350.

[0047] Figure 3E₃ shows the axial movement of actuator 356 distally to a position where the sealing member 358 is positioned to actuate distal clips or brackets 364 and release the distal end of implant. Again, a radio-opaque marker 374 (perhaps with an additional identification band 376) has been depicted to show alignment of the radio-opaque marker or band 360 on the actuator shaft 356 prior to the increase in pressure for deployment.

- [0048] Figure 3E₄ shows final deployment at the implant 354 and proximal movement at the actuator 356, just prior to withdrawal of the delivery guide 350. The distal and proximal clips or brackets (362, 364) have relaxed to the surface of the delivery guide 350.
- [0049] Alternatives to certain of the elements shown in the variation found in Figs. 3E₁ to 3E₄ is seen in Figs. 3F₁ and 3F₂ and includes, e.g., a cover element 380 to block or cover proximal orifices 366 during the pressurization of the distal orifices 368. The cover element 380 includes holes 382 to allow fluid flow past the cover element 380.
- [0050] Fig. 3G₁ shows a variation of the described system in which an implant or stent 371 is maintained in position on a hollow delivery guide 373 using spring clips 375 proximally and 377 distally. The spring clips hold the implant 371 in place during delivery and against guide member 373. An actuator 379 is used to remove the clips 375, 377 sequentially and to release each end of implant 371 in an independent fashion. Clips 375 and 377, after actuation or release, remain interior to the guide member 373 for later removal with that guide member. The system shown in Figures 3G₁, 3G₂ and 3G₃ may be used to deliver a number of implants in a sequential fashion. Since the retainer clips 375, 377 remain within the guide member 373 after delivery, the actuator 379 is able to slide past the site on guide member 373 where the clips 375, 377 resided prior to implant 371 deployment, down to and distally to a site on the guide member having another implant for subsequent delivery. Consequently, an arrangement such as this may be used to deploy, in a sequential fashion, a number of stents or the like without withdrawal of the guide member.
- [0051] In the variation shown in Figs. 3G₁, 3G₂ and 3G₃, the clips 375 and 377 are spring-biased to collapse within the lumen 381 of the guide member 373 once they are pushed into the respective slots 383 provided for such retraction. Such spring loaded clips retain the self expanding stent or implant 371 onto the face of guide member 373. Each of clips 375, 377 are shown in this variation to have hook members 387, 389 that engage the implant 371, often axially stretching the implant 371 and maintaining the delivery radius of the implant 371 as shown.
- [0052] As shown in Fig. 3G₁, actuator 379 is pushed distally along the outer surface of guide member 373 until it contacts the proximal end of clip 375. Further distal movement of actuator 379 urges clip 375 into lumen 381 thereby rotating horn 387 out of cooperating receptacle area in implant 371.
- [0053] Fig. 3G₂ shows the results of such movement after clip 375 has completed its springed closure within lumen 381. As shown in that Figure, the proximal end of implant 371 has

expanded and yet the distal end of implant 371 remains closed and hooked to distal clip 377. This semi-open condition allows for some adjustment of the implant if needed. Fig. 3G3 shows the results of additional distal movement of actuator 379 until it contacts distal clip 377 (shown in Fig 3G3 in its collapsed form) and thereby allowing the distal end of implant 371 to self-expand into the chosen treatment site.

[0054] Fig. 3G₃ shows that guide member 379 is free. Implant 371 is shown in its self expanded form no longer adjacent the central guide member 379. Actuator 379 is situated within implant 371 and is no longer in contact with proximal clip 375 nor distal clip 377. Actuator 379 is thus able to continue distally to another implant containing site positioned in a more distal site on the guide member 373.

[0055] The mechanical variation shown in Figs. 3G₁, 3G₂, 3G₃ may be modified in such a way that the actuator is interior to the lumen of the guide member and deploys the implant upon distal movement of the actuator by providing an actuator with a slot or other “room-making” provisions or features in the actuator. The actuator and any retained clips would then be used to actuate the clips in the next more distal implant if so desired.

[0056] In yet a further variation, the system releases an implant (shown as a stent 404 in Fig. 4) attached to a delivery guide 400 by one or more attachment arms 402 positioned, e.g., at the implant proximal and distal ends, by sliding a tubular member 406, mounted co-axially on the delivery guide 400, distally over the delivery guide 400. The stent 404 is secured to the delivery guide 400 when the attachment arms 402 are in a radially expanded configuration (as illustrated in Figure 4). The tubular member 406 urges the attachment arms 402 into a compressed configuration as it slides distally over the delivery guide 400, in the direction of the arrow. When the attachment arms 402 are compressed by the tubular member 406, they are moved inward from the stent 404, toward the central axis of the delivery guide 400, thereby releasing the stent 404 from the delivery guide 400. Stent detachment occurs in a serial fashion as the tubular member 406 is moved distally, with detachment of the stent proximal end 408 occurring before detachment at the stent distal end 410. Consequently, if the stent position requires readjustment after detachment of the stent proximal end, the stent may be repositioned prior to detaching the stent distal end. In one variation, the tubular member is a balloon catheter.

[0057] The attachment arms 402 are generally made from the same materials as the delivery guide 400, e.g., stainless steel or nickel-titanium alloy, and will typically have a length, thickness, shape, and flexibility appropriate for its intended mechanism of release. The distal

ends 412 of the attachment arms may be of any design, so long as one or more of them, when in a radially expanded configuration, secures a portion of a stent to a delivery guide, and when in a compressed configuration, releases that same stent portion from the delivery guide.

[0058] The tubular member may be a thin-walled tube (e.g., approximately 0.005 cm (0.002 inches) in thickness) with an outside diameter ranging from about 0.025 cm to about 0.139 cm (0.010 inches to about 0.055 inches), more usually from about 0.025 cm to about 0.05 cm (0.010 inches to about 0.020 inches), and more usually still from about 0.025 cm to about 0.035 cm (0.010 inches to about 0.014 inches). Depending on such factors as degree of flexibility or durometer required, they may be made from various metals or metal alloys, including, but not limited to, stainless steel and nickel-titanium alloy, or from various polymers, such as polyvinyl chloride, polyethylene, polyethylene terephthalate, and polyurethane.

[0059] Figures 5A, 5B, and 5C show a variation of the described delivery system 500 in which a member of electrolytic delivery joints are used to deploy an implant 502, such as a stent.

[0060] The electrolytic delivery joints shown here (e.g., 504 in Figure 5C) are well known as controllable delivery joints for placement of vaso-occlusive coils. One such commercially available device using an electrolytically detachable joint is sold by Target Therapeutics, a subsidiary of Boston Scientific Corp., as the Guglielmi Detachable Coil (or "GDC").

Numerous patents to Dr. Guglielmi describe the theory of its use.

[0061] In essence, the electrolytically erodible joint is a section of an electrical circuit that is not insulated and is of a metallic material that does not form insulating oxides when exposed to an aqueous environment (e.g., aluminum and tantalum) and is sufficiently "non-noble" that it will either electrolytically erode by ionic dissolution into an anatomical fluid or, perhaps, electrochemically erode by forming readily soluble oxides or salts.

[0062] The erodible joint 504 shown in Figure 5C is a bare metal of a size, diameter, etc. that erodes away when a current is applied to insulated wire 506. The current flow is from a power supply through insulated wire 506, bare joint 504, into the ionic anatomical fluid surrounding the site to be treated, and back to a return electrode situated perhaps on the patient's skin and then back to the power supply. The current flows through the circuit so long as the joint 504 exists.

[0063] With that background, Figure 5A shows a device having several joints (504, 508, 510, 512) that each may be independently severed to controllably deploy the implant 502. Implant 502 is shown having coils (514, 516) that are terminated at each end by an erodible joint and

that, prior to the severing of a joint, hold this implant 502 to the surface of the delivery member 520. The implant 500 is self-expanding, once released. The wires forming the two coils in this variation slide within the implant or “uncoil” and thereby allow the implant body itself to expand. The coils may comprise (if electrically connected to the erodible joint) a metal that is higher in the Mendeleev Electromotive Series than is the composition at the electrolytic joint or the coils may comprise a polymer that may be bio-erodible or not.

[0064] In any case, a suitable way to assure that the coils (514, 516) maintain the low profile of the implant 502 during delivery is via the placement of the various conductive wires (506, 516, 518, 520) through the adjacent holes (524, 526, 528) and fill the holes with e.g., an epoxy to hold all in place. Independently causing current to flow through each of the joints will release the implant in the region of the released joint. Once all joints are eroded, the implant is released.

[0065] Although release from proximal and distal ends of the tubular form of the implants has been described, detachment from a delivery guide is not so limited. In another variation, the stent is attached to the delivery guide at one or more positions along the length of the stent, in addition to attachment at the proximal and distal implant ends. Once the distal stent end is released, the additional attachments may be independently released until detachment at the proximal implant end releases the implant entirely from the delivery guide. Serial release may provide better control of positioning in tubular organs.

[0066] Figs. 5D and 5E show in more detail, the components of an electrolytic joint (as may be found in Figs 5A, 5B and 5C) and another electrically actuated joint using a meltable or softenable or polymerically sizable joint .

[0067] Fig. 5D shows the insulated wire 524 with insulation 523 and conductor 525. The electrolytic joint 504 is also shown. In this variation, the wire 524 is shown to be secured into the delivery guide wall 520 by, e.g., an epoxy 527, an alternative or cooperative band or component 529 holding the wire 524 to the surface of guide member 520 is also shown. After erodable joint 504 is eroded, the implant of 502 expands and leaves the securement band 529 on the delivery guide 520.

[0068] Fig. 5E shows a similar variation but the joint comprises a thermoplastic adhesive or shape changing polymer 531 situated on the end of wire 525 and within a cup or other receptacle 533. The adhesive is of the type that changes form or viscosity upon application of current to the joint. In this variation, the thermoplastic is rendered conductive, but resistive, by introduction of material such as carbon black into the polymeric adhesive. As soon as the

polymer changes its shape, form, or phase, the implant expands to the desired form about the central guide member 520 again, the wire may be held in place with an adhesive 527 if so desired.

[0069] Although the figures show wires and other remnants of the joints remaining exterior to the central guide member 520 and the others shown and described here, it is desirable that these not be situated in such a way that they will harm the tissues into which they are placed.

[0070] Another variation of the invention is shown in Fig. 10. Note that this variation of the invention (or any of the others described herein) is optionally set in the packaging as also shown in Fig. 10 and described in further detail below.

[0071] In any case, Fig. 10 portrays a delivery guide member 1000 with a stent 1002 held in a collapsed configuration upon a core wire 1004. A sheath 1006 is provided over and around the stent. A "core wire" as used herein generally comprises a common metallic member. However, the wire may be coated or covered by a polymeric material (e.g., with a lubricious material such as TEFLON®) or otherwise. Still further, the "wire" may be a hybrid structure comprised of a metal and a polymeric material (e.g. Vectra™, Spectra™, Nylon, etc.) or composite material (e.g., carbon fiber in a polymer matrix). The wire may be a filament, bundle of filaments, cable, ribbon or in some other form; however, it is generally not hollow.

[0072] The portion of sheath 106 restraining the stent may fully surround the stent or only subtend a partial circumference of the stent, it may be split, splittable, comprise a plurality of member or may otherwise be provided around the stent to hold or restrain it in a collapsed profile. Oftentimes, the sheath (especially when provided as a tubular member) will be polymeric material, such as polyamide or PET. However, the sheath may comprise hypotube. "Hypotube" or "hypotubing" as referred to herein means small diameter tubing in the size range discussed below, generally having a thin wall. The hypotube may specifically be hypodermic needle tubing. Alternatively, it may be wound or braided cable tubing, such as provided by Asahi Intec Co., Ltd or otherwise. As with the "wire" discussed above, the material defining the hypotube may be metallic, polymeric or a hybrid of metallic and polymeric or composite material.

[0073] To accommodate stent 1002, the core member/wire may be stepped down in size to form a recessed stent receiving area 1008 as shown. Such a configuration is generally desired in that (at least at the distal end), the sheath restraining the stent can be straight-gauge or constant diameter material. However, alternative configurations are contemplated.

- [0074] Delivery guide 1000 will typically have an atraumatic tip 1010. This feature, together with having the stent ride or be set over an integral core wire (thereby stabilizing the same and offering the potential to capture the stent at both ends with stop sections 1012 or along at least a portion of its length by an underlying core member pattern complimentary to the stent pattern, etc.), distinguishes this embodiment of the present invention structurally and functionally from a basic sheath and pusher type system or one that rides over a discrete guidewire. In addition, the latter type of systems can not be made as small as this embodiment of the present invention (for reason of at least the clearance requirements for the guidewire lumen).
- [0075] By providing a minimalistic system in which there is only a core wire including a distal atraumatic tip and a sheath to restraint the stent, a highly cost and space-efficient delivery solution is provided. Stated otherwise, the delivery guide substantially consists of a core member or wire, having an atraumatic tip and a sheath (at least at the distal end). Yet another way of describing this embodiment of the invention is to say that it has no movable member intermediate to the sheath and core member. Yet, it includes a highly desirably and efficacious atraumatic tip.
- [0076] From any perspective, in this system, the core member and any stop or other stent-holding features are fixed such that relative movement between them is not possible. Accordingly, when sheath 106 is withdrawn, the stent is unable to move proximally and, thus, expands as the sheath is removed from its body.
- [0077] As for the atraumatic tip required of the variation of the invention shown in Fig. 10 (or possibly used in other variations of the invention), it may comprise a plurality of spring coils (as shown) attached to a tapered wire section. At a distal end the coils typically terminate with a bulb or ball that is often made of solder. In such a construction, the coils and/or solder are often platinum alloy or another radiopaque material. Of course, the wire section to which the coils are attached may be tapered, but need not be tapered. In addition, alternate constructions for the atraumatic tip are possible. For instance, molding or dip-coating with a polymer may be employed. In one example, the atraumatic tip may comprise a molded tantalum-loaded 35 durometer Pebax™ tip. However constructed, the atraumatic tip may be straight or curved; the latter configuration possibly assisting in directing or steering the delivery guide to a desired intravascular site or other treatment location.

- [0078] While many of the other variations of the invention may not require an atraumatic tip (even though it is often highly advantageous), such a structure is required of the delivery guide 1000. On the other end of the delivery device, a custom handle 1014 is preferably provided.
- [0079] Handle 1014 is adapted for rotating actuation by holding body 1016, and turning wheel 1018. This might be a one-handed or a two-handed operation. Naturally, other handle designs are contemplated. A full range of reciprocal actuators including sliders, or other rotating means such as rollers operating in either axis normal to that shown may be employed. In addition, other form-factors for the handle may be adopted. Examples include pen-like and puck-like shapes. Generally, less bulky system will be preferred to facilitate handling and minimize delivery system dislodgement or position loss in the case of dropping the same.
- [0080] However, configured, the handle may include a lock 1020 as shown. In addition, the handle system shown includes a removable interface member 1022 to facilitate removal of the handle from a proximal length 1024 of the delivery system. In which case, the interface piece will be lockable with respect to the body and preferably includes internal features for disengaging the handle from the delivery guide. Once accomplished, it will be possible to attach or "doc" a secondary length of wire 1026 on the delivery system's proximal end, allowing the combination to serve as an "exchange length" guidewire, thereby facilitating changing-out the balloon catheter or performing another procedure. Alternatively, the wire may be an exchange-length wire.
- [0081] Packaging 1050 for any of the delivery systems (1000, etc.) may include one or more of an outer box 1052 and one or more inner trays 1054, 1056 with peel-away coverings as is customary in packaging of disposable products provided for operating room use. Naturally, instructions for use can be provided therein. Such instructions may be printed product 1058 or be provided in connection with another readable (including computer-readable) medium. The instructions may include provision for basic operation of the subject devices and/or methodology.
- [0082] As for the delivery systems in Fig. 11A-11C, it offers some similarity to the sheath-based delivery system of Fig. 10. The primary difference is that in this case, the "sheath" holding the stent in a collapsed configuration is, in fact, a balloon catheter. The construction of the devices, may otherwise be identical.
- [0083] In this regard, Fig. 11A shows the distal end of a core wire 1100 and 1100'. Both wires are shown tapering in sections 1106 from a larger diameter proximal section 1102 to a smaller stent-carrying section 1104. Wire 1100' includes yet another taper 1108 to accommodate a

coil tip 1110 as shown in Fig. 11B. Depending on the size of the device, were no taper 1108 is provided, it may be desired to decrease the overall thickness of the stent carrying section and portions distal thereto in order to achieved sufficient flexibility.

[0084] Proximal to the stent carrying section 1104 is a stop 1112 or blocker. As shown, this member is affixed or connected to the core wire. Yet, it could be provided integrally therewith such as by grinding the feature in the core member (e.g., by decreasing the taper of section 1106). A distal stent stop 1114 is shown provided in connection with atraumatic coil tip 1110.

[0085] In Fig. 11C, the assembly of Fig. 11B is brought together with a stent 1116 held in a collapsed configuration by balloon catheter 1118 carrying at least one balloon. The balloon 1120 of the catheter is shown inflated. However, during delivery, that will obviously not be the case. Depending on the configuration of the device, the balloon might be the primary balloon for effecting predilatation. In the alternative, it may simply be used for postdilatation of an emplaced stent.

[0086] In any case, stent release will typically be effected by withdrawing the catheter body 1122 until a distal end 1224 of catheter 1118 clears the stent. With such a system, stent release may be accomplished in the smallest of vessels. By incorporating the balloon into the restraint for the stent, the system enables one to forgo the use of separate balloon catheter and stent delivery systems. At minimum, this consolidation can reduce the number of steps required to complete a procedure (thus reducing operating time).

[0087] Yet another class of delivery guides is shown in Figs. 12A-14B. In each of a number of different ways, these delivery systems hold a radially-expandable prosthesis (such as a stent) in a collapsed configuration for delivery without the use of a restraint or active (hinging, deforming, electrolytically corroding, etc.) latching or locking members as in the other variations of the invention.

[0088] Figs 12A and 12B show of first of these devices. As with the other variations of the invention above, delivery guide 1200 preferably includes an atraumatic tip 1202. A body or shaft 1204 of the device in the form of a tube or sleeve includes hooks 1206 at a distal end. The body is advantageously made of hypotubing in order to manufacture the hooks integral thereto.

[0089] Complementary hooks 1206' are formed distal thereto and supported by core member 1208. Hooks 1206' may be formed in connection with a ring 1210 or be provided otherwise. In any case, the hooks (numbering at least two per side to balance forces) are dimensioned with a prong 1212 and recess 1214 suited for receipt of a stent. Together a complementary set of

hooks 1206/1206' receive a stent and stretch it to hold it in a collapsed form when stretched or extended axially as shown in Fig. 12B. Additionally, or alternatively, a twisting mode of stent compression or retention may be employed.

[0090] Regardless, in the configuration shown where the hooks have no overhang (so as to facilitate stent release) the system relies on friction between the stent and hooks to hold the stent in place when the stent is axially stretched. Still, interference features between the stent and hooks may be provided to facilitate hold-down. Whatever the case, stent release is accomplished by releasing the tension and/or torque holding the stent in its collapsed profile.

[0091] While the system of Figs. 12A and 12B is suited for use in holding a stent in simple tension, by twisting alone, or by a combination of these modes, the variation of the invention shown in Figs. 13A and 13B is specifically adapted for incorporation of at least some twisting to hold down the stent. In this variation of the invention, a delivery guide 1300, again, preferably includes an atraumatic tip 1302. Furthermore, a body or shaft 1304 (advantageously, hypotubing) and a core wire member 1308 are provided. However, in the variation shown in Figs. 13A and 13B, rather than providing radially-oriented hooks radially oriented thread-like graspers 1306 and 1306'. At a proximal side of the device, they are shown integral with the hypotube. At a distal end, they are shown fabricated in connection with a ring 1310.

[0092] As shown in Fig. 13B, the graspers (ranging in number from at least one per side to very many – acting like teeth) capture a complementarily shaped stent 1312 having keys 1314 sized to fit within grasper slots 1316. As mentioned above, a stent is collapsed or at least held in collapsed state for delivery by imparting a torque to the system. In addition, the stent may be placed under tension as indicated – pushing the core wire forward relative to the hypotube (or vice versa). Naturally, release will be effected upon removal of the wind-up and/or pull-down forces. In which case, the stent will be able to expand and free its keys 1314 from slots 1314 by way of radial expansion.

[0093] A final mode of twist-based stent hold down is illustrated in connection with Figs. 14A and 14B. Fig. 14B shows a chuck-type 1400 feature having a body 1402 and a plurality of extensions 1404 therefrom. The body may be provided by hypotubing or a separate member. In any case, the device is preferably configured to ride over a core wire 1406 of a delivery as with the hook or grasper features in the preceding variations of the invention.

[0094] The number of extension will depend on the stent 1408 with which the chuck is designed to interface. As shown in Fig. 14B, a four-extension chuck interfaces neatly with a

stent including four strut ends 1410. When closely-packed as shown, counter rotation of complementary pairs of chucks 1400 will capture the stent. Thus captured, the stent may be held down to a core member for delivery by this mode alone. In the alternative, some measure of tension may be applied thereto. Whatever the hold-down mode desired, it can be appreciated that the system of Figs. 14A and 14B represents a sort of "self-locking" system.

[0095] What is more, the retention system is very compact and can be made quite robust as shown in the to-scale drawings provided of the same. In order that the stent pack so cleanly as shown when twisted, it may be desired to pre-curve its shape. That is to say, the stent may be configured so that when it is twisted that its members go from a pre-twisted shape to a straightened configuration as shown. The amount of shaping to account for hold-down twist, may be in the form of a simple bias or helix, S-curves or other shape(s). The particular configuration of the stent or degree of pre-twist/pre-curve as will be effective in facilitating the most efficient implant packing may be determined through iterative design or by modeling techniques that are well know in the art. Naturally, these pre-shaping principles to account for or accommodate the twisting of the stent as discussed with respect to the variation of the invention shown in Figs. 14A and 14B may be applied to the other variation of the invention employing a torque or twist to the implant in holding the same in preparation of an for delivery.

Delivery Method

[0096] The implant delivery devices described herewith may include multiple implants on a single delivery guide or may be used in conjunction with other instruments, as seen appropriate, to treat the target site. In general, the tubular organ of interest is percutaneously accessed, but the method of accessing will usually be dependent on the anatomy of the organ, medical condition being treated, health status of the subject, and the like. Consequently, access by a laparoscopic or open procedure may also be obtained.

[0097] Figures 6A-6D show the general method of deploying a stent using my described system. After obtaining access to the tubular organ of interest 600 (blood vessel in Figure 6A), a delivery guide 602 is placed through the selected area of stenosis 604 at the target site. A balloon catheter 606 is then advanced over the delivery guide 602, and balloon angioplasty performed to dilate the area of stenosis 604 (Figure 6B). The balloon catheter 606 is then retracted proximally and the delivery guide 602 exchanged for a stent delivery device 608 (Figure 6C). Appropriate placement of the stent is guided by radioopaque markers 616 on the delivery guide 612. The distal end 610 of the stent is then released from the delivery guide

612. At this point, stent position may again be checked by verifying the location of the radioopaque markers. The proximal stent end 614 is then released from the delivery guide 612.

[0098] If desired, an embolic filter may be used during stent deployment to filter any debris generated during the procedure. The filter will usually be attached to the delivery guide such that it filters debris distal to the stent, but may also be attached to the delivery guide proximal to the stent, or both distal and proximal to the stent. The filter may be of any design, as long as it does not affect the substantially atraumatic, low profile, and controlled release characteristics of the stent delivery device. Typically, the filter is basket-shaped, and made from a shape-memory material, e.g., an alloy of titanium and nickel. The filter will usually be contained within the balloon catheter lumen, and deployed to its pre-designed shape once the balloon catheter is removed. Following placement of the stent, the balloon catheter may be advanced over the delivery guide to enclose the filter with any accumulated debris. The balloon catheter, filter, and delivery guide may then be removed from the body.

[0099] Turning now to Fig. 7 a heart 702 is shown in which its vessels may be the subject of one or more angioplasty and/or stenting procedures in more specific methodology according to the present invention. To date, however, significant difficulty or impossibility is confronted in reaching smaller coronary arteries 704. If a stent and a delivery system could be provided for accessing such small vessels and other difficult anatomy, an additional 20 to 25% percutaneous coronary procedures could be performed with such a system. Such a potential offers opportunity for huge gains in human healthcare and a concomitant market opportunity in the realm of roughly \$1 billion U.S. dollars – with the further benefit of avoiding loss of income and productivity of those treated.

[00100] Features of the present invention are uniquely suited for a system able to reach small vessels (though use of the subject systems is not limited to such a setting.) By “small” coronary vessels, it is meant vessels having an inside diameter between about 1.5 or 2 and about 3 mm in diameter. These vessels include, but are not limited to, the Posterior Descending Artery (PDA), Obtuse Marginal (OM) and small diagonals. Conditions such as diffuse stenosis and diabetes produce conditions that represent other access and delivery challenges which can be addressed with a delivery system according to the present invention. Other extended treatment areas addressable with the subject systems include vessel bifurcations, chronic total occlusions (CTOs), and prevention procedures (such as in stenting vulnerable plaque).

- [00101] Assuming a means of delivering one or more appropriately-sized stents, it may be preferred to use a drug eluting stent in such an application to aid in preventing restenosis. However, bare-metal stents may be employed in the present invention. The present invention is advantageously employed with self-expanding stents. However, the teachings herein may be adapted for application in the context of balloon-expandable stents.
- [00102] In any case, features of the present invention are provided in order to hold a prosthesis or implant (e.g., a stent) to be delivered in an access or deployment configuration, after which, the implant assumes its deployed or expanded configuration. Hold-down features may restrain a stent under compressive forces, whereupon release, the stent “springs” open. Alternatively, the stent (or other implant) may simply be secured to the delivery member, where some other mechanism is used to open the stent (e.g., ceasing a flow of chilled saline, thereby allowing a shape memory devices (e.g., NiTi) to warm in order that a material phase change from martinsite to austenite will cause the stent to open).
- [00103] While some might argue that the particular role and optimal usage of self expanding stents has yet to be defined, they offer an inherent advantage over balloon expandable stents. The latter type of devices produce “skid mark” trauma (at least when delivered uncovered upon a balloon) and are associated with a higher risk of end dissection or barotraumas caused at least in part by high balloon pressures and related forces when deforming a balloon-expandable stent for deployment.
- [00104] Yet, with an appropriate deployment system, self-expanding stents may offer one or more of the following advantages over balloon-expandable models: 1) greater accessibility to distal, tortuous and small vessel anatomy – by virtue of decreasing crossing diameter and increasing compliance relative to a system requiring a deployment balloon, 2) sequentially controlled or “gentle” device deployment, 3) use with low balloon pre-dilatation (if desirable) to reduce barotraumas, 4) strut thickness reduction in some cases reducing the amount of “foreign body” material in a vessel or other body conduit, 5) opportunity to treat neurovasculature – due to smaller crossing diameters and/or gentle delivery options, 6) the ability to easily scale-up a successful treatment system to treat larger vessels or vice versa, 7) a decrease in system complexity, offering potential advantages both in terms of reliability and system cost, 8) reducing intimal hyperplasia, and 9) conforming to tapering anatomy – without imparting complimentary geometry to the stent (though this option exists as well).
- [00105] At least some of these noted advantages may be realized using a stent 810 as shown in Fig. 8 in connection with the subject deployment system described in further detail below.

Naturally, other stent configurations might be used instead. However, the one pictured is well suited for use in small vessels. It may be collapsed to an outer diameter of about 0.018 inch (0.46 mm), or even smaller to about 0.014 inch (0.36 mm) -including the restraint/joint used - and expand to a size (fully unrestrained) between about 1.5 mm (0.059 inch) or 2 mm (0.079 inch) or 3 mm (0.12 inch) and about 3.5 mm (0.14 inch).

[00106] In use, the stent will be sized so that it is not fully expanded when fully deployed against the wall of a vessel in order that it will provide a measure of radial force thereto. The force will secure the stent and offer potential benefits in reducing intimal hyperplasia and vessel collapse or even pinning dissected tissue in apposition.

[00107] The stent employed in connection with the subject delivery system preferably comprises NiTi that is superelastic at room temperature and above. Also, it is preferably electropolished. The stent may be a drug eluting stent (DES). Such drug can be directly applied to the stent surface(s), or introduced into an appropriate matrix. Note that the term "stent" as used herein refers to any coronary artery stent, other vascular prosthesis, or other radially expanding or expandable prosthesis or scaffold-type implant suitable for the noted treatments or otherwise. Exemplary structures include wire mesh or lattice patterns and coils, though others may be employed in the present invention. A "self expanding" stent is a scaffold-type structure (serving any of a number of purposes) that expands by its own action from a reduced-diameter configuration to an increased-diameter configuration. The "diameter" need not be circular – it may be of any open configuration. Self-expanding materials may be so by virtue of simple elastic behavior, superelastic behavior, a shape memory effect (i.e., heat-activated transformation from martensite to austenite) or some other manner. Since the stents will remain in the subject's body, the material should be biocompatible or at least be amenable to biocompatible coating. As such, suitable self expanding stent materials for use in the subject invention include NiTi alloy (e.g., NITINOL) and various other alloys or polymers.

[00108] For a typical self-expanding stent 0.014 inch delivery system (one in which the maximum nominal outer diameter of the stent/coating and guide member/restraint have a diameter that does not exceed 0.014 inch), the thickness of the NiTi is about 0.0025 inch (0.64 mm) for a stent adapted to expand to 3.5 mm. Such a stent is designed for use in a 3 mm vessel or other body conduit, thereby providing the desired radial force in the manner noted above. Further information regarding radial force parameters in coronary stents may be noted in the article, "Radial Force of Coronary Stents: A Comparative Analysis," Catheterization and

Cardiovascular Interventions 46: 380-391 (1999), incorporated by reference herein in its entirety.

- [00109] As for the stent that may be employed, an optional expanded stent cut pattern 810 is shown in Fig. 8. In one manner of production, the stent is laser (or Electrical Discharge Machining, i.e., EDM) cut from round NiTi tubing, with the flattened-out pattern shown wrapping around the tube as indicated by dashed lines. In such a procedure, the stent is preferably cut in its fully-expanded shape. By initially producing the stent to full size, the approach allows cutting finer details in comparison to simply cutting a smaller tube with slits and then heat-expanding/annealing it into its final (working) diameter. Avoiding post-cutting heat forming also reduces production cost.
- [00110] Regarding the finer details of the subject stent, necked down bridge or junction sections 812 are provided between adjacent struts 814, wherein the struts define a lattice of closed cells 816. The ends 818 of the cells are preferably rounded-off so as to be atraumatic. To increase stent conformability to tortuous anatomy, the bridge sections can be strategically separated or opened as indicated by broken line. To facilitate such tuning of the stent, the bridge sections are sufficiently long so that fully rounded ends 818 may be formed internally to the lattice just as shown on the outside of the stent if the connection(s) is/are severed to separate adjacent cells 816.
- [00111] The advantage of the double-concave profile of each strut bridge or junction section 812 is that it reduces material width (relative to what would otherwise be presented by a parallel side profile) to improve trackability and conformability of the stent within the subject anatomy while still maintaining the option for separating/breaking the cells apart.
- [00112] Further optional features of stent 810 are employed in the cell end regions 818 of the design. Specifically, strut ends 820 increase in width relative to medial strut portions 822. Such a configuration results in a majority of bending (during collapse of the stent) occurring along the length of the struts rather than at the corners of the cells. Longer struts to allow for lower stresses within the stent (and, hence, possibility for higher compression ratios). Shorter struts allow for greater radial force (and concomitant resistance to a radially applied load) upon deployment.
- [00113] In order to provide a stent that collapses as much as possible (to solid or near-solid structure, such as shown in the fully-loaded systems of the figures) accommodation is made for the stiffer strut ends 820 provided in the design shown in Fig. 8. Namely, the gap 824 between the strut ends 822 is set at a smaller angle as if the stent were already partially collapsed in that

area. Thus, the smaller amount of angular deflection that occurs at ends 820 will bring the sections parallel (or nearly so) when the strut medial portions 822 are so-arranged. Radiused sections 826 provide a transition from a medial strut angle α (ranging from about 85 degrees to about 60 degrees) to an end strut angle β (ranging from about 30 to about 0 degrees). In addition, it is noted that gap 824 and angle β may actually be configured to completely close prior to fully collapsing angle α . The value of doing so would be to limit the strains (and hence, stresses) at the strut ends 822 and cell end regions 818 by providing a physical stop to prevent further strain.

[00114] By utilizing a design that minimizes strain, very high compression ratios of the stent may be achieved. Compression ratios (from a fully expanded outside diameter to compressed outside diameter – expressed in those terms used by physicians) of as much as 3.5 mm : 0.014 inch (about 10X) are possible – with or without a drug coating and/or restraint used. Compression ratios of 3.0 mm : 0.014 inch (about 8.5X), 3.5 mm : 0.018 inch (about 7.5X), 3.0 mm : 0.018 inch (about 6.5X), 2.5 mm : 0.014 inch (about 7X), 2.5 mm : 0.018 inch (about 5.5X), 2.0 mm : 0.014 inch (about 5.5X), 2.0 mm : 0.018 inch (about 4.5X) offer utility not heretofore possible with existing systems as well.

[00115] These selected sizings (and expansion ratios) correspond to treating 1.5 to 3.0 mm vessels by way of delivery systems adapted to pass through existing balloon catheter and microcatheter guidewire lumen. In other words, the 0.014 inch and 0.018 inch systems are designed to corresponding common guidewire sizes. The system may also be scaled to other common guidewire sizes (e.g., 0.22 inch / 0.56 mm or 0.025 inch / 0.64 mm) while offering advantages over known systems.

[00116] While designing the delivery systems to have a crossing profile corresponding to common guidewire sizes, especially for full-custom systems, intermediate sizes may be employed. Still further, it is contemplated that the system sizing may be set to correspond to French (FR) sizing. In that case, system sizes contemplated range at least from 1 to 1.5 FR, whereas the smallest know balloon-expandable stent delivery systems are in the size range of about 3 to about 4 FR.

[00117] At least when produced at the smallest sizes (whether in a even/standard guidewire or FR size, or otherwise), the system enables a substantially new mode of stent deployment in which delivery is achieved through an angioplasty balloon catheter or small microcatheter lumen. Further discussion and details of “through the lumen” delivery is presented in the above-referenced “Balloon Catheter Lumen Based Stent Delivery Systems” patent application.

- [00118] In “small vessel” cases or applications (where the vessel to be treated has a diameter up to about 3.0 mm), it may also be advantageous to employ a stent delivery system sized at between about 0.022 to about 0.025 inch in diameter. Such a system can be used with catheters compatible with 0.022 inch diameter guidewires.
- [00119] While such a system may not be suitable for reaching the very smallest vessels, in reaching the larger of the small vessels (i.e., those having a diameter of about 2.5 mm or larger), even this variation of the invention is quite advantageous in comparison to known systems. By way of comparison, the smallest known over-the-guidewire delivery system (the “Pixel” system – produced by Guidant) that is adapted to treat vessels between 2 and 2.5 mm has a crossing profile of 0.036 inch (0.91 mm). A system described in U.S. Patent Publication No. 2002/0147491 for treating small vessels is purported to be capable of being made as small as 0.026 inch (0.66 mm) in diameter.
- [00120] With respect to the Pixel and ‘491 systems, however, it must be appreciated that a further decrease in stent size may be practically impossible in view of materials limitations and functional parameters of the stent. Instead, the present invention offers a different paradigm for delivery devices and stents that are scalable to the sizes noted herein.
- [00121] By virtue of the approaches taught herein, it is feasible to design system diameters to match (or at least nearly match) common guidewire size diameters (i.e., 0.014, 0.018 and 0.022 inch) for small vessel delivery applications. As noted above, doing so facilitates use with compatible catheters and opens the possibility for methodology employing the same as elaborated upon below and in the above-referenced “Balloon Catheter Lumen Based Stent Delivery Systems” patent application.
- [00122] Of further note, it may be desired to design a variation of the subject system for use in deploying stents in larger, peripheral vessels, biliary ducts or other hollow body organs. Such applications involve a stent being emplaced in a region having a diameter from about 3.5 to about 13 mm (0.5 inch). In this regard, the scalability of the present system, again, allows for creating a system adapted for such use that is designed around a common wire size. Namely, a 0.035 to 0.039 inch (3 FR) diameter crossing profile system is advantageously provided in which the stent expands (unconstrained) to a size between about roughly 0.5 mm and about 1.0 mm greater than the vessel or hollow body organ to be treated. Sufficient stent expansion is easily achieved with the exemplary stent pattern shown in Fig. 8.
- [00123] Again, as a matter of comparison, the smallest delivery systems known to applicants for stent delivery in treating such larger-diameter vessels or biliary ducts is a 6 FR system

(nominal 0.084 inch outer diameter), which is suited for use in an 8 FR guiding catheter. Thus, even in the larger sizes, the present invention affords opportunities not heretofore possible in achieving delivery systems in the size range of a commonly used guidewire, with the concomitant advantages discussed herein.

[00124] Several known stent delivery systems are compatible with (i.e., may be delivered over) common-sized guides wires ranging from 0.014 inch to 0.035 inch (0.89 mm). Yet, none of the delivery systems are themselves known to be so-sized.

[00125] As for the manner of using the inventive system as optionally configured, Figs. 3A-3L illustrate an exemplary angioplasty procedure. Still, the delivery systems and stents or implants described herein may be used otherwise – especially as specifically referenced herein.

[00126] Turning to Fig. 9A, a coronary artery 930 is shown partially or totally occluded by plaque at a treatment site/lesion 932. Into this vessel, a guidewire 40 is passed distal to the treatment site. In Fig., 9B, a balloon catheter 942 with a balloon tip 944 is passed over the guidewire, aligning the balloon portion with the lesion (the balloon catheter shaft proximal to the balloon is shown in cross section with guidewire 940 therein).

[00127] As illustrated in Fig. 9C, balloon 944 is expanded (dilatated or dialated) in performing an angioplasty procedure, opening the vessel in the region of lesion 932. The balloon expansion may be regarded as “predilatation” in the sense that it will be followed by stent placement (and optionally) a “postdilataton” balloon expansion procedure.

[00128] Next, the balloon is at least partially deflated and passed forward, beyond the dilate segment 932’ as shown in Fig. 9D. At this point, guidewire 940 is removed as illustrated in Fig. 9E. It is exchanged for a delivery guide member 950 carrying stent 952 as further described below. This exchange is illustrated in Figs. 3E and 3F.

[00129] However, it should be appreciated that such an exchange need not occur. Rather, the original guidewire device inside the balloon catheter (or any other catheter used) may be that of item 950, instead of the standard guidewire 940 shown in Fig. 9A. Thus, the steps depicted in Figs. 9E and 9F (hence, the figures also) may be omitted. In addition, there maybe no use in performing the step in Fig. 9D of advancing the balloon catheter past the lesion, since such placement is merely for the purpose of avoiding disturbing the site of the lesion by moving a guidewire past the same.

[00130] Fig. 9G illustrates the next act in either case. Particularly, the balloon catheter is withdrawn so that its distal end 946 clears the lesion. Preferably, delivery guide 950 is held stationary, in a stable position. After the balloon is pulled back, so is delivery device 950,

positioning stent 952 where desired. Note, however, that simultaneous retraction may be undertaken, combining the acts depicted in Figs. 3G and 3H. Whatever the case, it should also be appreciated that the coordinated movement will typically be achieved by virtue of skilled manipulation by a doctor viewing one or more radiopaque features associated with the stent or delivery system under medical imaging.

[00131] Once placement of the stent across from dilated segment 932' is accomplished, stent deployment commences. The manner of deployment is elaborated upon below. Upon deployment, stent 952 assumes an at least partially expanded shape in apposition to the compressed plaque as shown in Fig. 9I. Next, the aforementioned postdilatation may be effected as shown in Fig. 9J by positioning balloon 944 within stent 952 and expanding both. This procedure may further expand the stent, pushing it into adjacent plaque – helping to secure each.

[00132] Naturally, the balloon need not be reintroduced for postdilatation, but it may be preferred. Regardless, once the delivery device 950 and balloon catheter 942 are withdrawn as in Fig. 9K, the angioplasty and stenting procedure at the lesion in vessel 930 is complete. Fig. 9L shows a detailed view of the emplaced stent and the desired resultant product in the form of a supported, open vessel.

[00133] In the above description, a 300 cm extendable delivery system is envisioned. Alternatively, the system can be 190 cm to accommodate a rapid exchange of monorail type of balloon catheter as is commonly known in the art. Of course, other approaches may be employed as well.

[00134] Furthermore, other endpoints may be desired such as implanting an anchoring stent in a hollow tubular body organ, closing off an aneurysm, delivering a plurality of stents, etc. In performing any of a variety of these or other procedures, suitable modification will be made in the subject methodology. For example, in treating neurovasculature, peripheral vessel procedures or others there may be no need for a balloon catheter. Instead, a standard catheter or microcatheter may be employed to access a target site. Still, a balloon catheter might later be used to effect postdilatation of the prosthesis. As another alternative, a balloon catheter might be employed for predilatation (even post dilatation) and a regular catheter or microcatheter employed in connection with site access and stent delivery.

[00135] The procedure shown is depicted merely because it illustrates a potentially preferred mode of practicing the subject invention, despite the invention's potential for broader applicability in the various fields or applications noted herein as well as others. In addition,

variation of the illustrated procedure itself is contemplated – both in connection with those possible modifications noted above or others as may be apparent to those with skill in the art.

Applications

- [00136] The implant delivery system may be used in mammalian subjects, preferably humans. Mammals include, but are not limited to, primates, farm animals, sport animals, cats, dogs, rabbits, mice, and rats.
- [00137] The system may be employed for implant delivery into lumens of tubular organs including, but not limited to, blood vessels (including intracranial vessels, large vessels, peripheral vessels, aneurysms, arteriovenous malformations, arteriovenous fistulas), ureters, bile ducts, fallopian tubes, cardiac chambers, ducts such as bile ducts and mammary ducts, large and small airways, and hollow organs, e.g., stomach, intestines, and bladder. The system may also be employed for implant delivery into solid organs or tissues including, but not limited to, skin, muscle, fat, brain, liver, kidneys, spleen, and benign and malignant tumors. Preferably, the implant is delivered to a target site in a blood vessel lumen. Of special interest are coronary and neurovascular application. However, the invention is neither limited to such applications or those specifically noted herein.
- [00138] Clinically, the system may generally be used to treat stenosis of various tubular organs, arising from such etiologies as atherosclerosis, autoimmune conditions, scarring, or exterior compression, e.g., as may be seen with a neoplastic process. The system may also be used to treat medical conditions in which luminal occlusion is desired, e.g., to treat aneurysms, arteriovenous fistulas, and arteriovenous malformations. Furthermore, the system may be employed to deliver implants into such areas as joint spaces, spinal discs, and the intraperitoneal or extraperitoneal spaces.

General Features

- [00139] In regard to any such system, it is to be understood that conventional materials and techniques may be employed in the system construction. In this regard, it will often be desired to provide a lubricious coating or cover between moving components to reduce internal system friction.
- [00140] In addition, it is to be understood that various radiopaque markers or features may be employed in the system to 1) locate stent position and length, 2) indicated device actuation and stent delivery and/or 3) locate the distal end of the delivery guide. As such, various platinum (or other radiopaque material) bands or other markers (such as tantalum plugs) may be variously incorporated into the system. Alternatively, or additionally, the stent stop or blocker

member may be made of radiopaque material. Especially where the stent employed may shorten somewhat upon deployment, it may also be desired to align radiopaque features with the expected location (relative to the body of the guide member) of the stent upon deployment. For example, it may be desired to incorporate radiopaque features into the restraint and/or bridge or connector sections so that the deployment motion of the device is visible under fluoroscopy. Exemplary markers that may be of use are shown at a proximal end of the stent in Fig. 10 as elements A and A' – on the delivery guide body and restraint, respectively – and at a distal end of the stent on the sheath as element B, or otherwise.

- [00141] Connections are made between parts in any of a number of manners including fusing, bonding, welding (by resistance, laser, chemically, ultrasonically, etc), gluing, pinning, crimping, clamping or otherwise mechanically or physically joining, attaching or holding components together (permanently or temporarily). Except where particularly noted, materials conventionally employed in the medical arts may be employed.
- [00142] All existing subject matter mentioned herein (e.g., publications, patents, and patent applications, etc.) cited herein are hereby incorporated by reference in its/their entirety for all purposes to the same extent as if each individual publication, patent, or patent application were specifically and individually indicated to be so incorporated by reference. The referenced items are provided solely for their disclosure prior to the filing date of the present application. Nothing herein is to be construed as an admission that the present invention is not entitled to antedate such material by virtue of prior invention.
- [00143] Furthermore, it is to be understood that this invention is not limited to particular variations set forth and may, of course, vary. Various changes may be made to the invention described and equivalents may be substituted without departing from the true spirit and scope of the invention. In addition, many modifications may be made to adapt a particular situation, material, composition of matter, process, process act(s) or step(s), to the objective(s), spirit or scope of the present invention. All such modifications are intended to be within the scope of the claims made herein.
- [00144] Methods recited herein may be carried out in any order of the recited events which is logically possible, as well as the recited order of events. Furthermore, where a range of values is provided, it is understood that every intervening value, between the upper and lower limit of that range and any other stated or intervening value in that stated range is encompassed within the invention. Also, it is contemplated that any optional feature of the inventive variations

described may be set forth and claimed independently, or in combination with any one or more of the features described herein.

[00145] Reference to a singular item, includes the possibility that there are plural of the same items present. More specifically, as used herein and in the appended claims, the singular forms “a,” “and,” “said” and “the” include plural referents unless the context clearly dictates otherwise. It is further noted that the claims may be drafted to exclude any optional element. As such, this statement is intended to serve as antecedent basis for use of such exclusive terminology as “solely,” “only” and the like in connection with the recitation of claim elements, or use of a “negative” limitation. Unless defined otherwise herein, all technical and scientific terms used herein have the same meaning as commonly understood by one of ordinary skill in the art to which this invention belongs.

CLAIMS

[00146] Although the foregoing invention has been described in some detail by way of illustration and example for purposes of clarity of understanding, it will be readily apparent to those of ordinary skill in the art in light of the teachings of this invention that certain changes and modifications may be made thereto without departing from the spirit and scope of the appended claims. The breadth of the present invention is to be limited only by the literal or equitable scope of the following claims. That being said, we claim:

1. A system for treating a target site in a tubular organ, the system consisting essentially of:
 - an elongate delivery guide member having a proximal end and a distal end, the delivery guide member configured to direct at least one implant having an exterior and interior surface to an anatomical treatment site by manipulation by a user, the at least one implant having a delivery diameter prior to release of the at least one implant and located proximally of the distal end of the delivery guide member prior to release, and at least one releasable joint configured to maintain at least a section of the at least one implant at the delivery diameter until release of the at least one releasable joint, and
 - a balloon catheter,
 - wherein the delivery guide member is adapted for receipt within a lumen of the balloon catheter.
2. A system consisting essentially of the system of claim 1 and a guidewire, wherein the guidewire is adapted for receipt within a lumen of the balloon catheter.
3. A system consisting essentially of the system of claim 1 and an embolic filter, wherein the embolic filter is attached to the proximal end of the delivery guide member.
4. The system of claim 1, wherein the delivery guide member is positioned within the balloon catheter lumen.
5. An implant delivery system comprising:
 - an elongate delivery guide member having a proximal end and a distal end, the delivery guide member configured to direct at least one implant having an exterior and interior surface to an anatomical treatment site by manipulation of the delivery guide member by a user,
 - the at least one implant having a delivery diameter prior to release of the at least one implant and located proximally of the distal end of the delivery guide member prior to release, and
 - at least one releasable joint configured to maintain at least a section of the at least one implant at the delivery diameter until release of the at least one releasable joint,

wherein the delivery guide member has a diameter distally and proximally of the at least one implant that is substantially equal to the at least one implant delivery diameter, whereby a substantially atraumatic implant delivery system is provided.

6. An implant delivery system comprising:

an elongate delivery guide member having a proximal end and a distal end, the delivery guide member configured to direct at least one implant having an exterior and interior surface to an anatomical treatment site by manipulation by a user,

the at least one implant having a delivery diameter prior to release of the at least one implant and located proximally of the distal end of the delivery guide member prior to release, and

a plurality of releasable joints, each joint configured to maintain a section of the at least one implant at the delivery diameter until release of the releasable joints,

wherein the system is adapted for sequential release of the releasable joints.

7. A system for treating a target site in a tubular organ comprising:

the implant delivery system of claims 6 or 7, and

a balloon catheter.

8. The system claim 1, 5 or 6, wherein the delivery guide member is closed at its distal end.

9. The system of claim 8, wherein the distal end is closed by an atraumatic tip.

10. The system claim 1, 5 or 6, wherein the delivery guide member diameter distally and proximally of the at least one implant is about 0.010 inches to about 0.020 inches, whereby a low-profile delivery system is provided.

11. The system claim 1, 5 or 6, wherein the delivery guide member has no passageway from its proximal to its distal end.

12. The system claim 1, 5 or 6, further comprising an actuator for releasing the at least one releasable joint, wherein the delivery guide member has only a single passageway from

its proximal to its distal end, that passageway contains the actuator, and wherein that actuator does not extend beyond the distal end of the delivery guide member.

13. The system of claim 12, wherein the actuator for releasing the at least one releasable joint is affixed to the distal end of the delivery guide member.

14. The system claim 1, 5 or 6, wherein the delivery guide member comprises a distal guide section and a proximal guide section and a gap between the distal guide section and the proximal guide section and the at least one implant is located between the distal guide section and the proximal guide section.

15. The system claim 1, 5 or 6, wherein the delivery guide member is noninflatable.

16. The system of claim 1, 5 or 6, wherein the delivery guide member is tubular in form, having a lumen therein.

17. The system of claim 16, further comprising an actuator slidably located at least partially within the delivery guide member lumen and configured to release at least one releasable joint upon axial movement within the delivery guide member.

18. The system of claim 16, further comprising an actuator slidably located at least partially within the delivery guide member lumen and configured to release at least one releasable joint upon rotational movement within the delivery guide member.

19. The system of claim 16, wherein at least one releasable joint is configured to release upon application of fluid pressure in the delivery guide member lumen and further comprising a fluid director slidably located at least partially within the delivery guide member lumen and configured to direct fluid to and to release that selected at least one releasable joint.

20. The system of claim 16, wherein at least one releasable joint is configured to release upon application of a suitable DC current to the at least one releasable joint and further comprising an electrical conductor located at least partially within the delivery guide

member lumen to supply the suitable DC current to and to thereby release at least one releasable joint.

21. The system of claim 20, wherein the at least one releasable joint and electrical conductors are configured to simultaneously release more than one releasable joint.

22. The system of claim 1, 5 or 6, wherein the implant is a stent.

23. The system of claim 1, 5 or 6, wherein the implant is an occlusive coil.

24. The system of claim 1, 5 or 6, wherein the implant further comprises a therapeutic agent.

25. The system of claim 1, 5 or 6, wherein the delivery guide member further comprises a radiopaque marker.

26. The system of claim 1, 5 or 6, having flexibility and remote directability, such that a user may direct the distal end of the guide member into and introduce the at least one implant into a coronary artery solely by manipulation of the delivery guide member from its proximal end.

27. The system of claim 1, 5 or 6, wherein the system is guidewireless.

28. An implant delivery system comprising:
a self-expanding stent;
a guidewire having a proximal end and a distal end, the guidewire including a reduced diameter distal section, and an atraumatic distal tip; and
a sheath holding the stent in a collapsed configuration over the reduced diameter section.

29. An implant delivery system consisting essentially of:
a self-expanding stent;

a guidewire having a proximal end and a distal end, the guidewire including a reduced diameter distal section, and an atraumatic distal tip; and
a sheath holding the stent in a collapsed configuration over the reduced diameter section.

30. The system of claim 28, wherein the sheath comprises a balloon catheter.
31. A system for treating a target site in a tubular organ comprising:
the implant delivery system of claims 28, 29 or 30, and
a handle for retracting the sheath.
32. A method of retaining an implant, the method comprising:
providing a radially-expandable implant having two ends,
gripping the ends, and
pulling and twisting the ends to maintain the implant in a collapsed configuration until released.
33. The method of claim 32, wherein the gripping is with inactive members.
34. The method of claim 32, wherein the implant is a stent.
35. The method of claim 32, further comprising setting the implant over a core wire.

FIGURE 1A

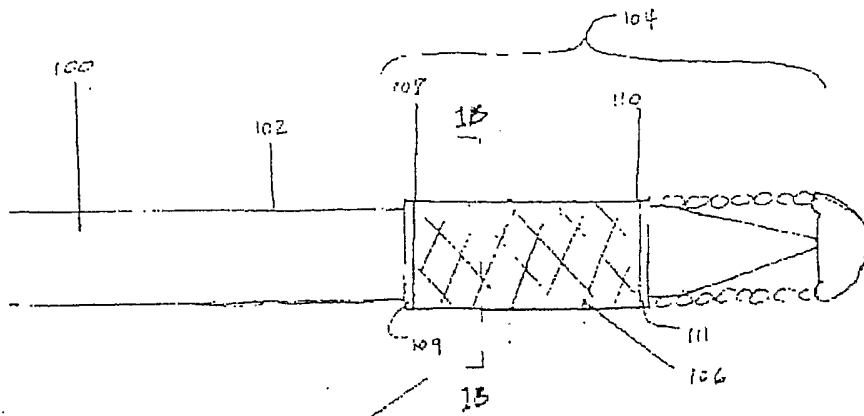

FIGURE 1B

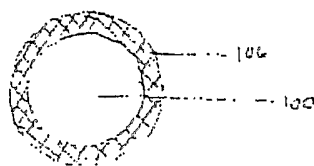

FIGURE 2

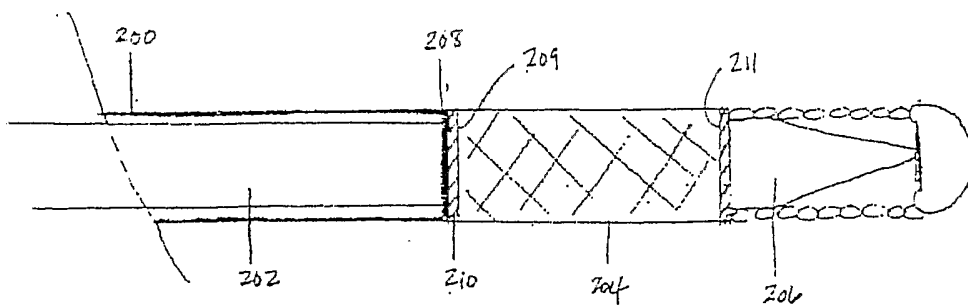

FIGURE 3A

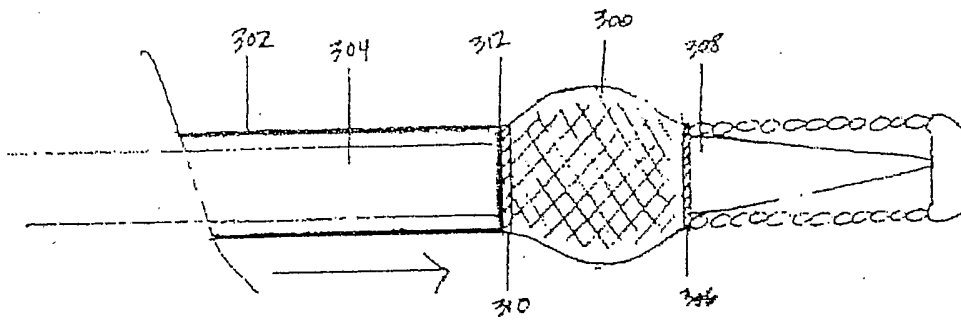

FIGURE 3B

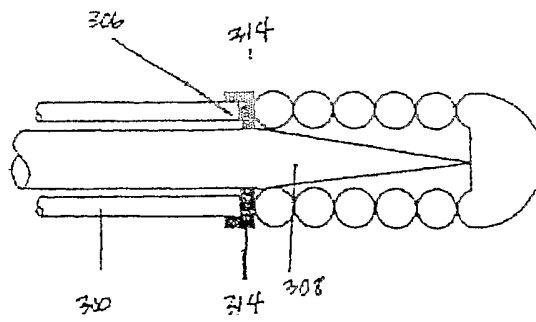

FIGURE 3C,

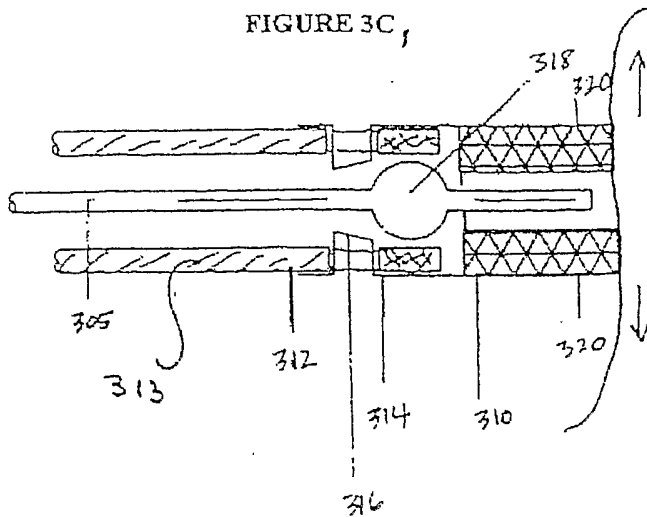
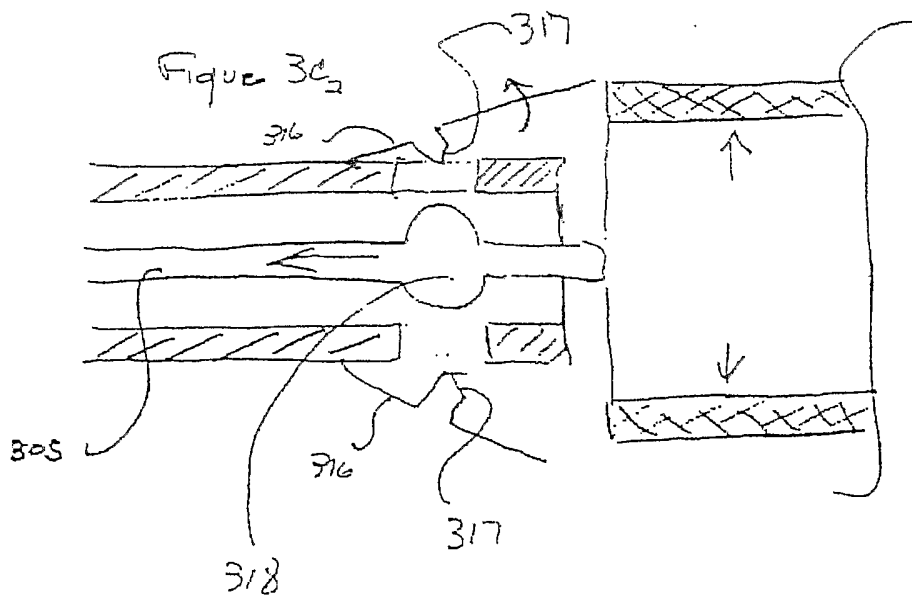
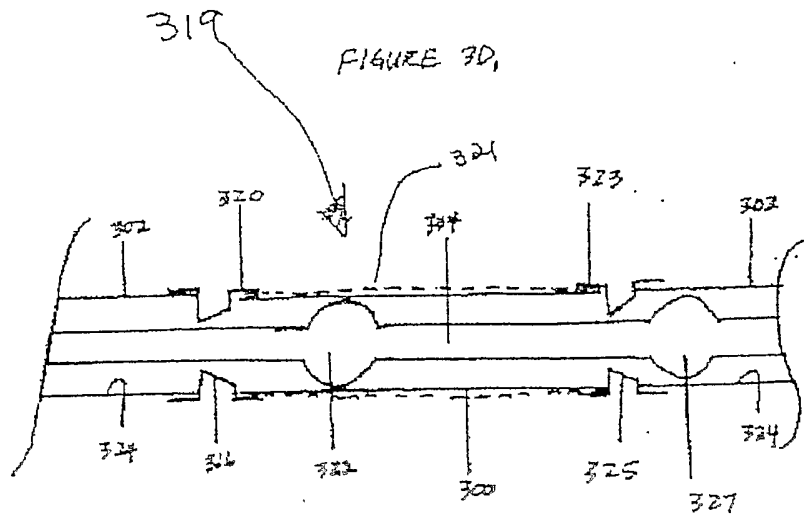
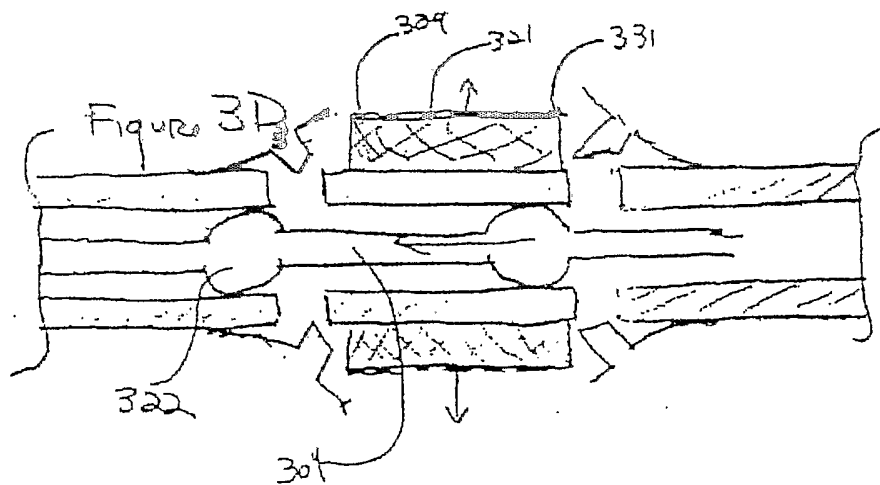
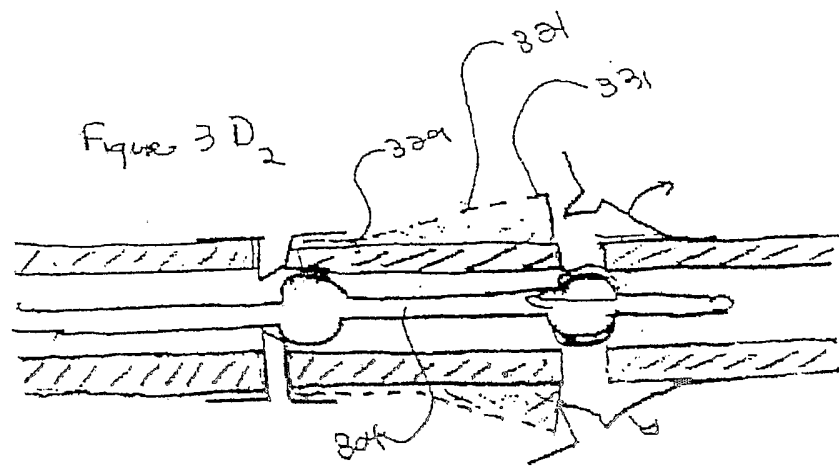

Figure 3C₂







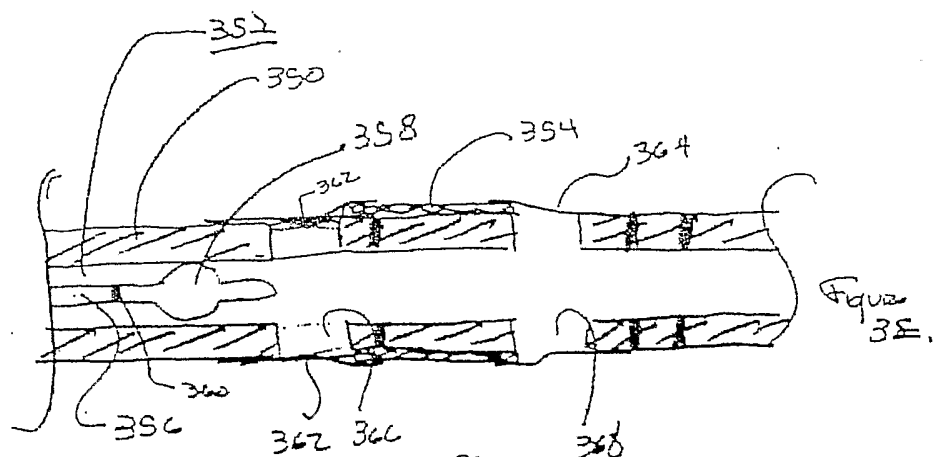

Figure 3E.

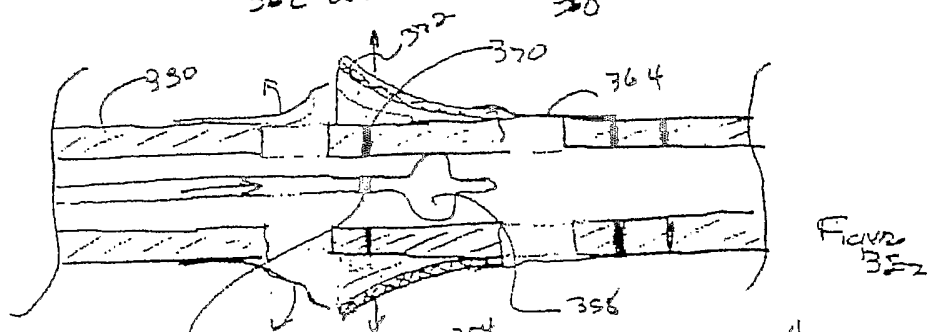

Figure 3E2

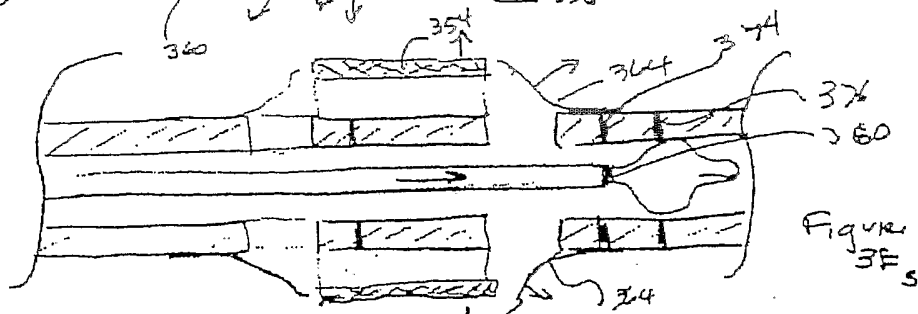

Figure 3E3

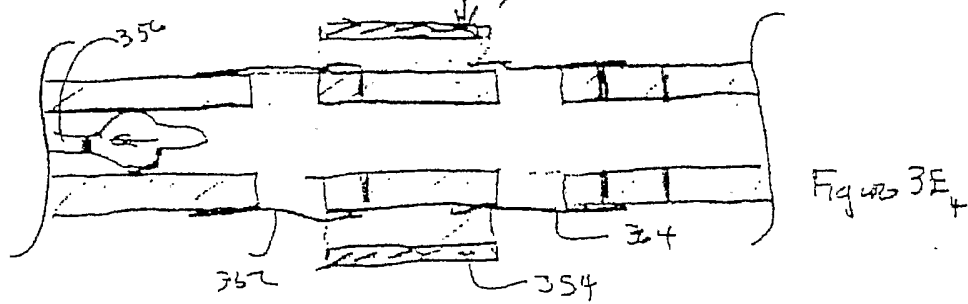
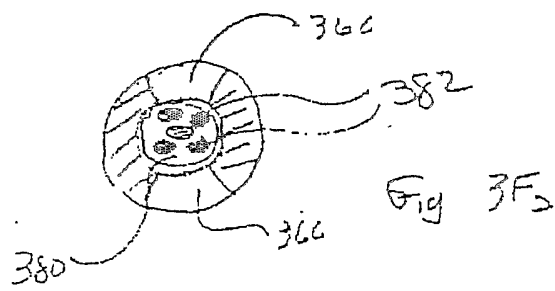
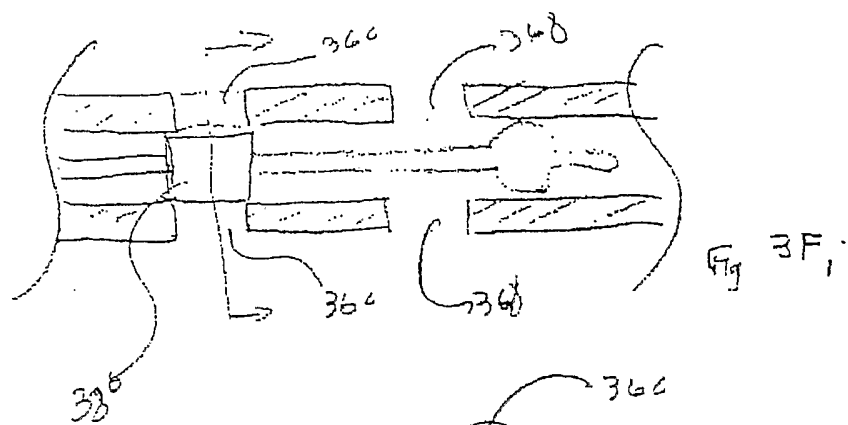

Figure 3E4



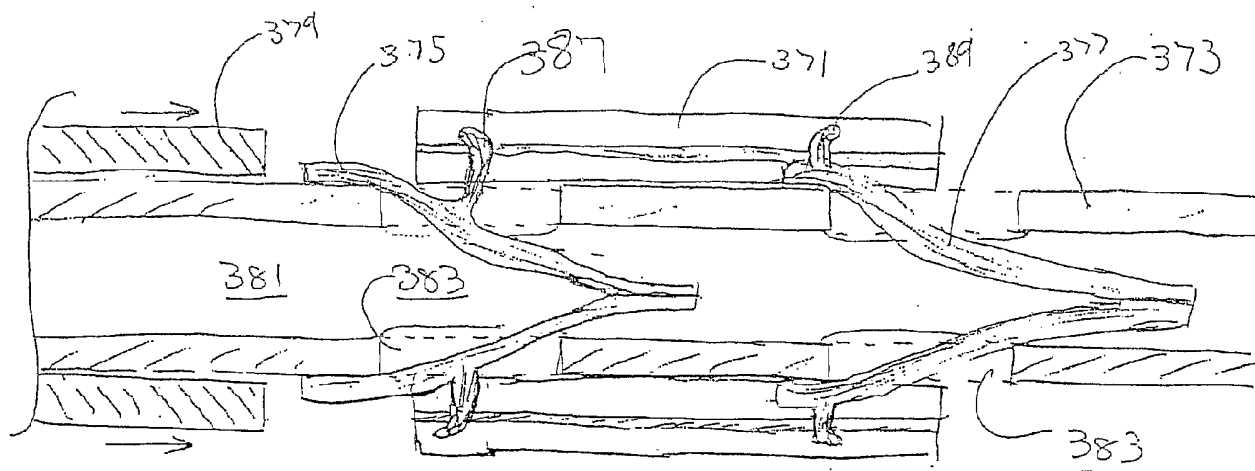

Figure 35,

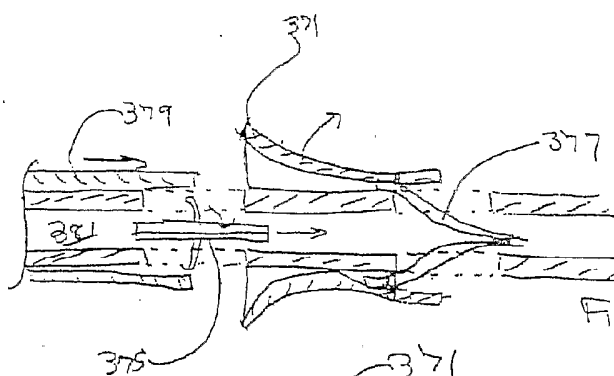

Figure 36.1

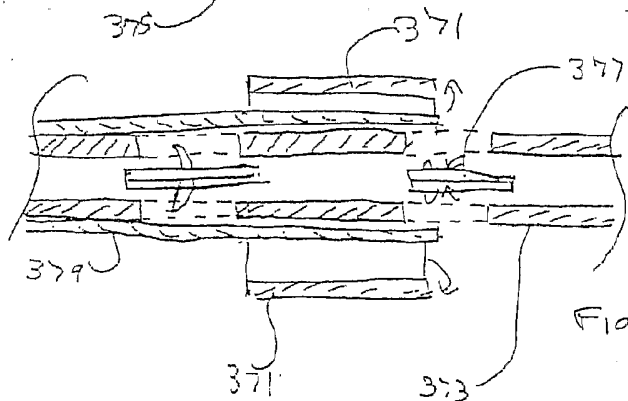
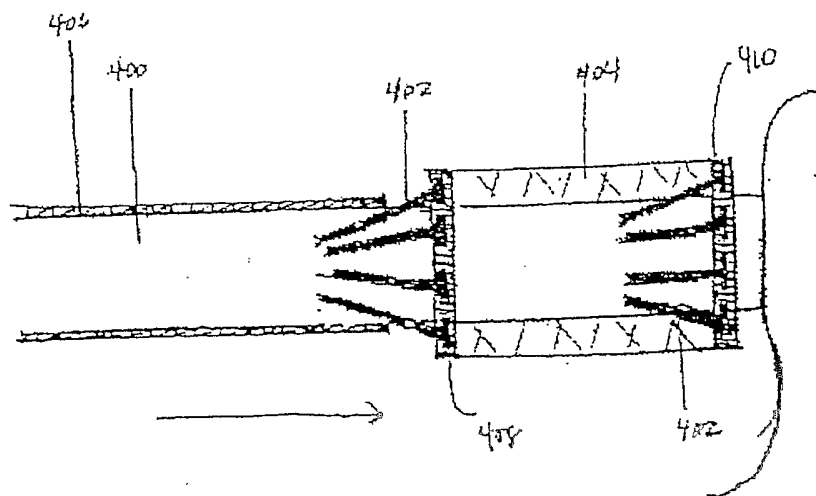
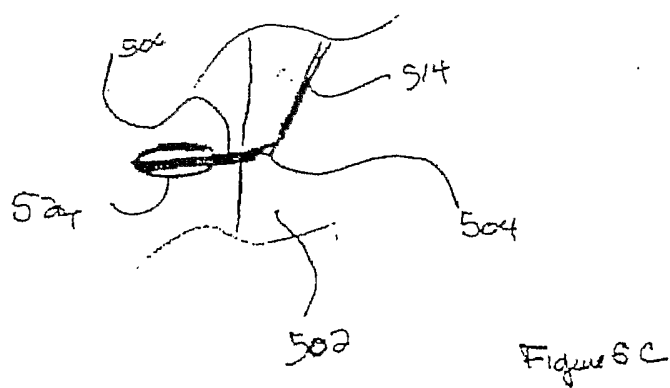
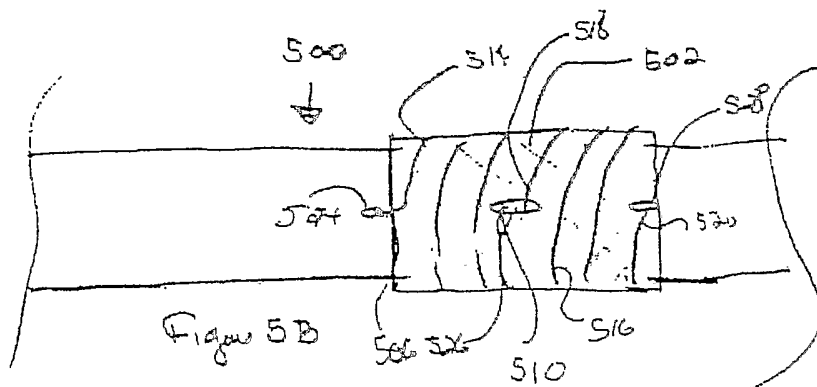
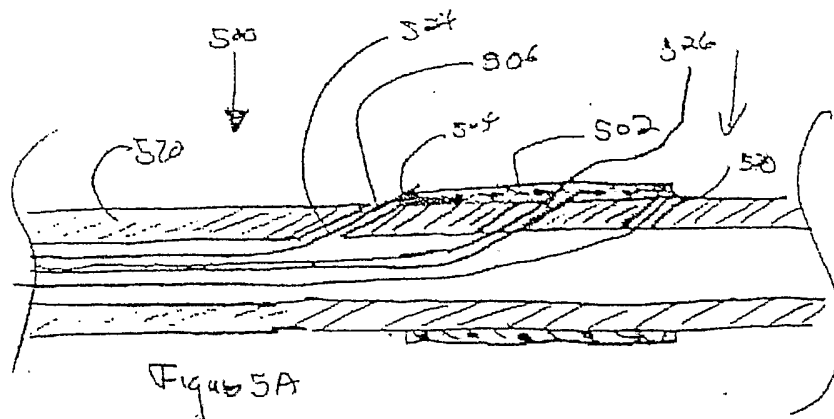

Figure 36.2

FIGURE 4





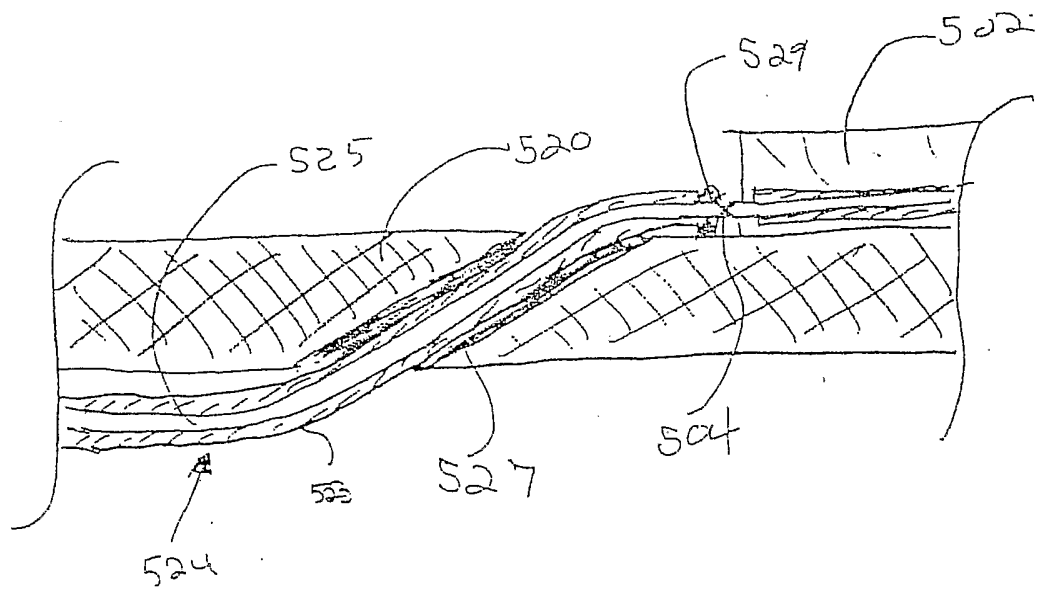

Figure 5D

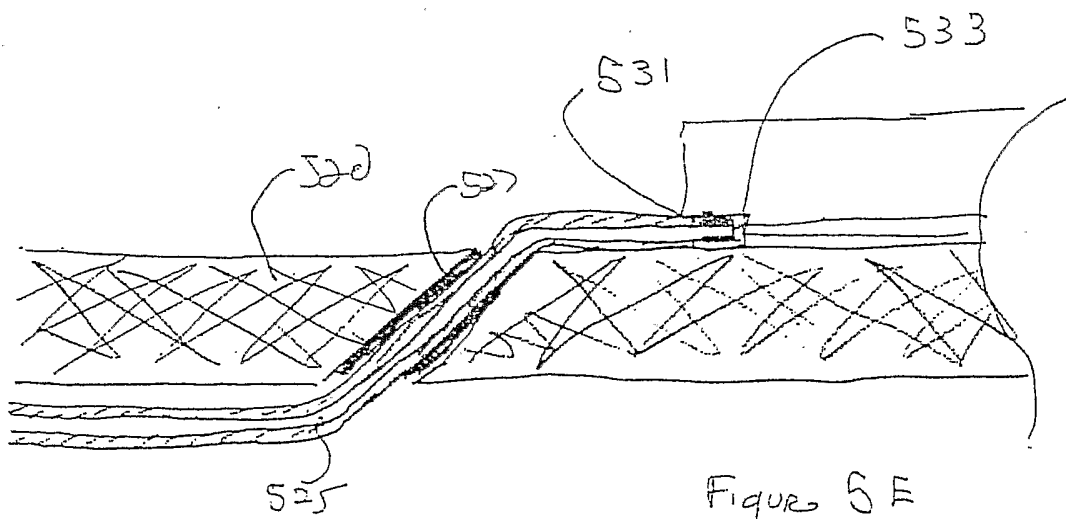

Figure 5E

FIGURE 6A

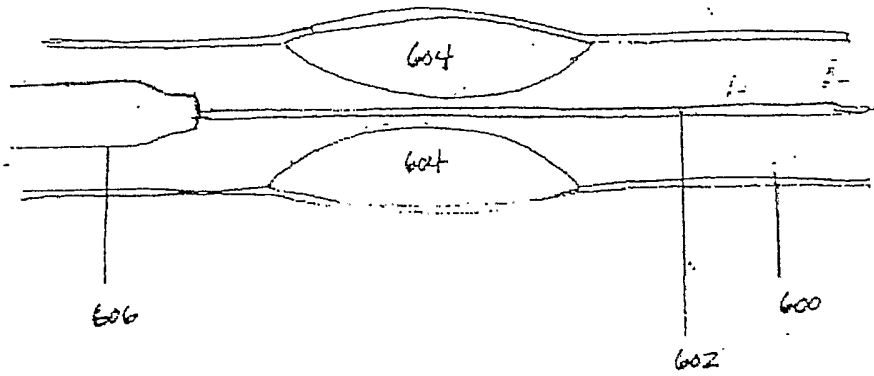

FIGURE 6B

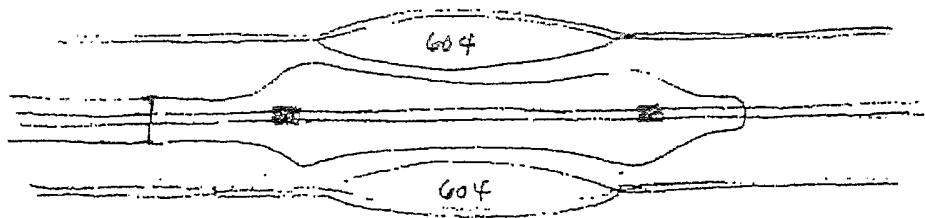

FIGURE 6C

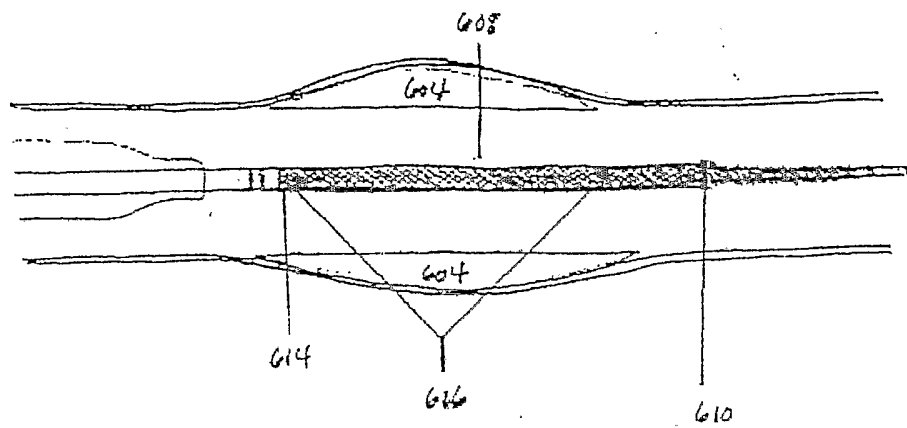
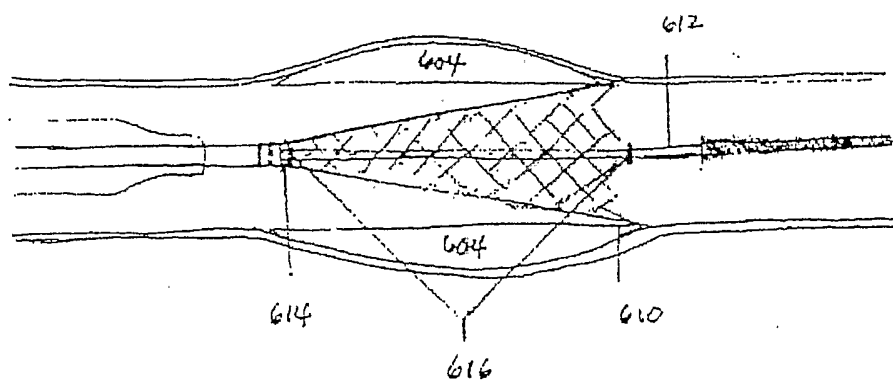

FIGURE 6D



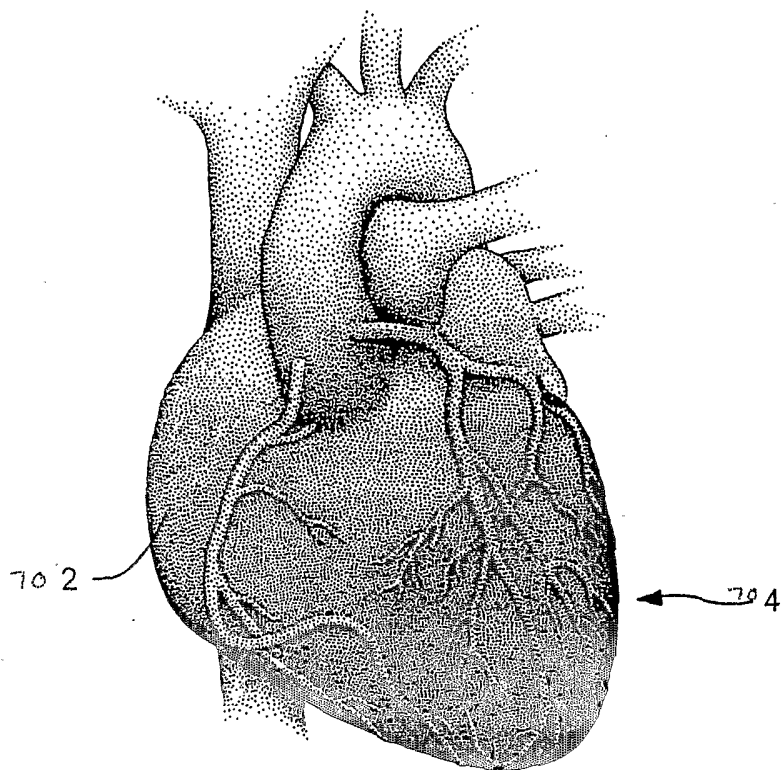

FIG. 7

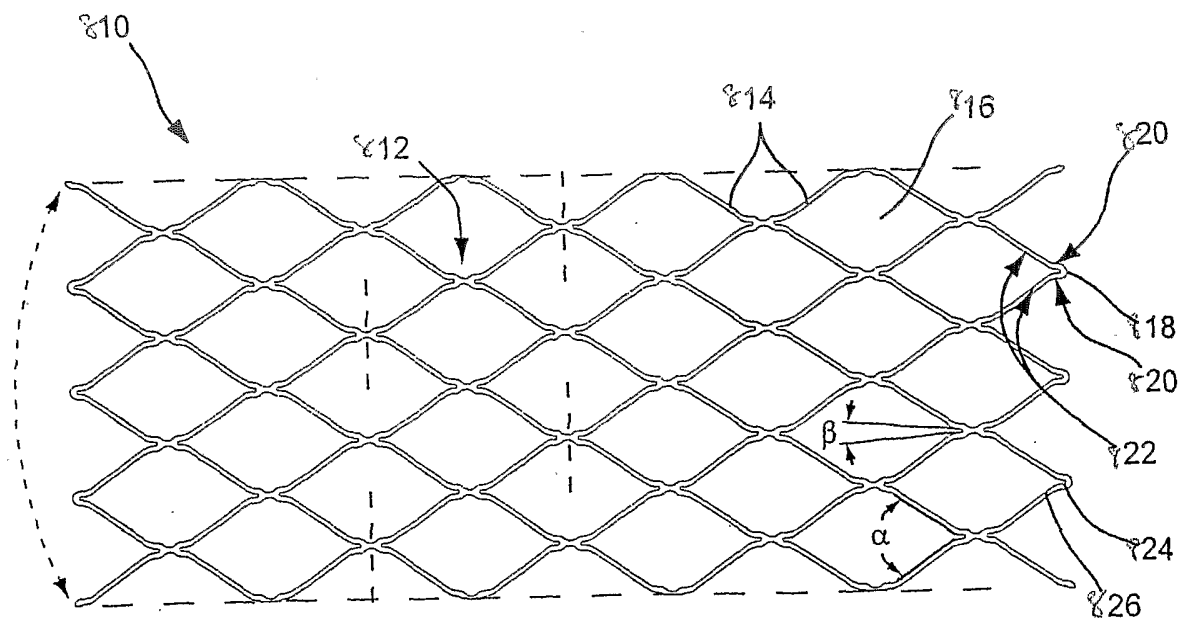

FIG. 8

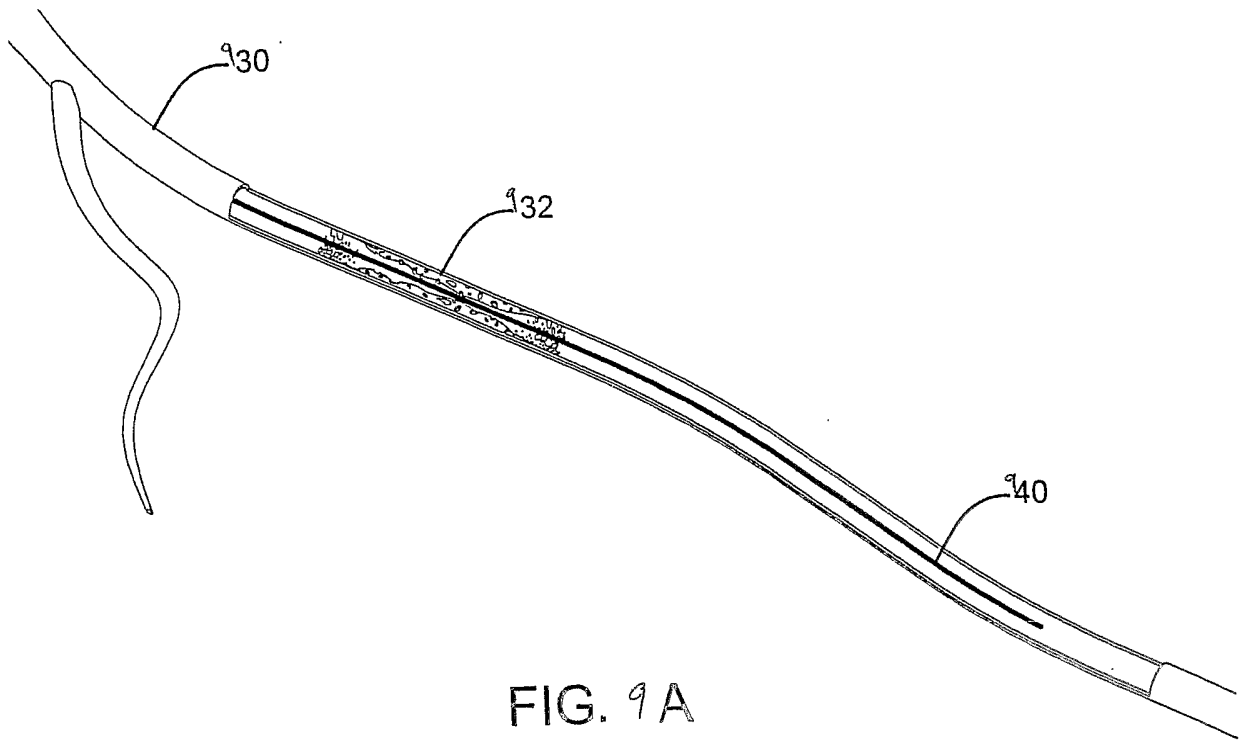

FIG. 9A

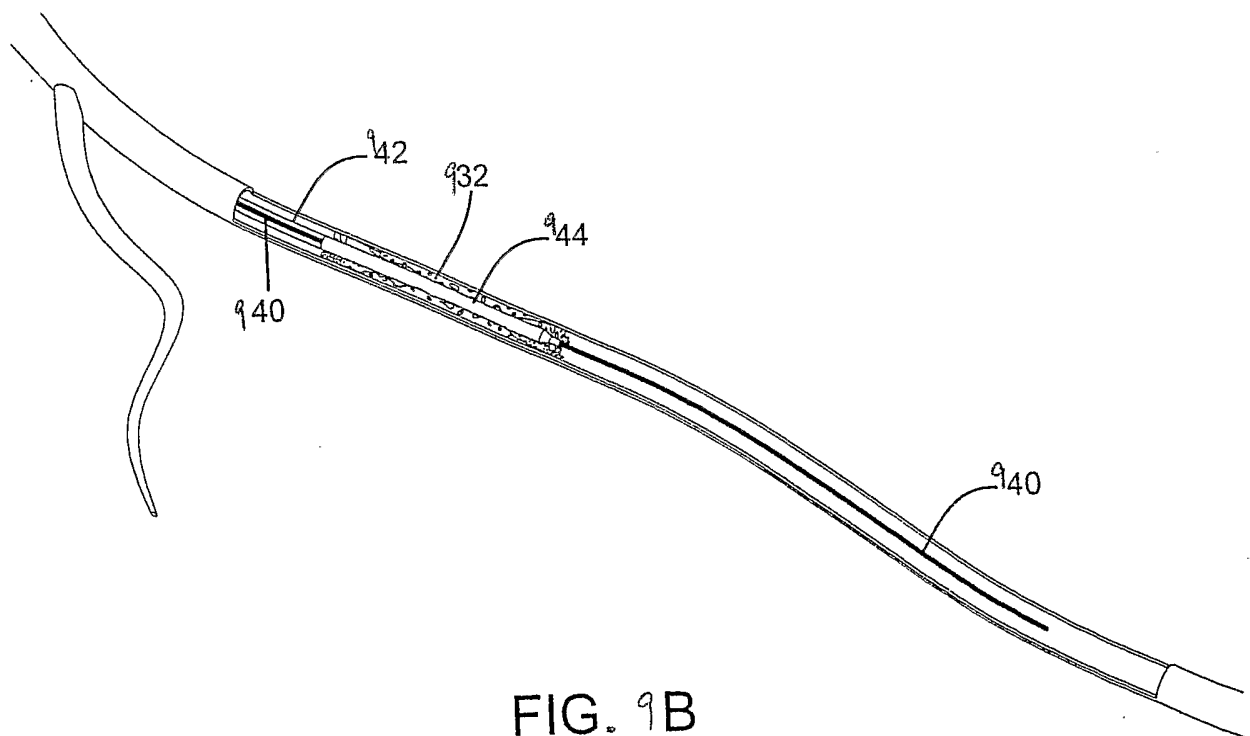

FIG. 9B

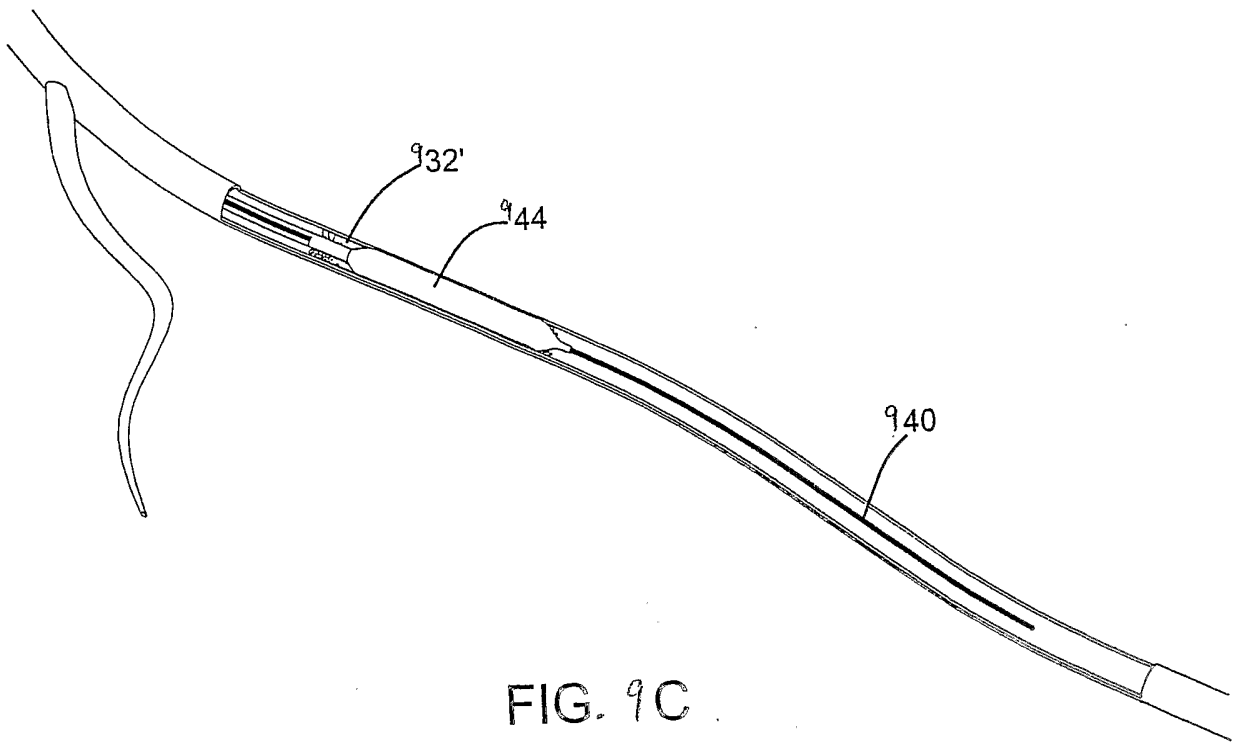

FIG. 9C

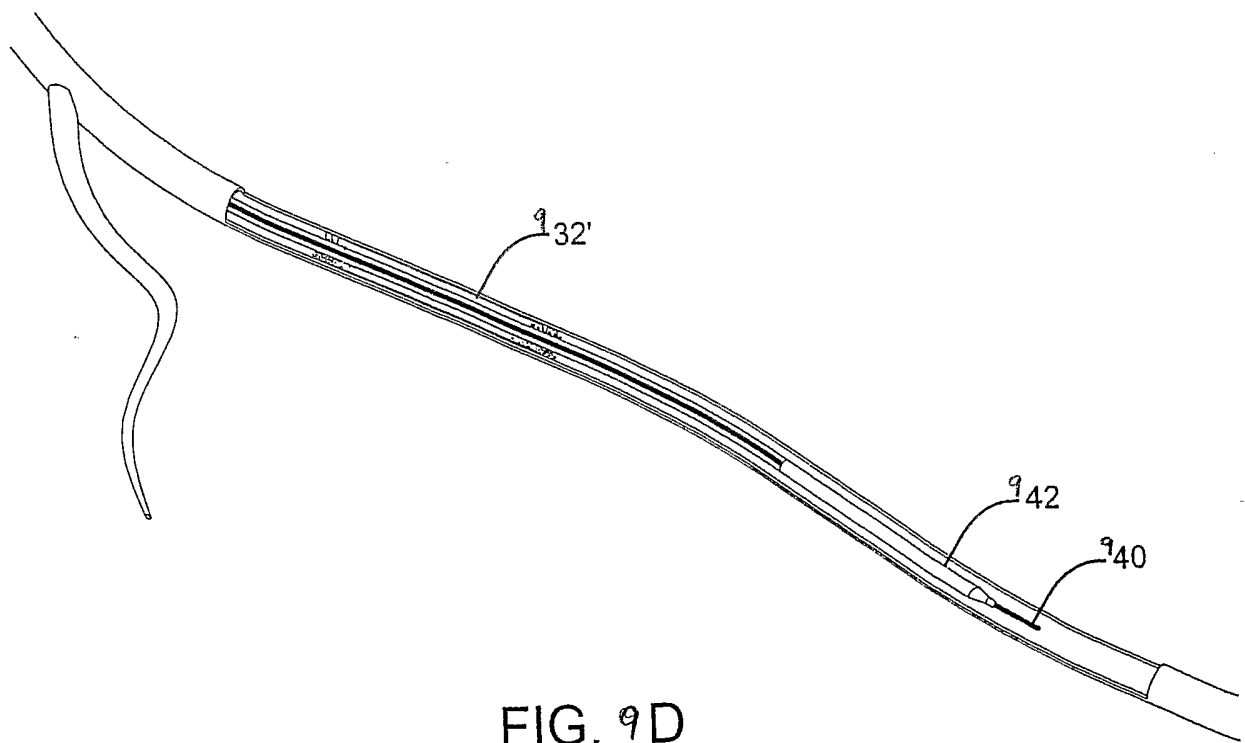

FIG. 9D

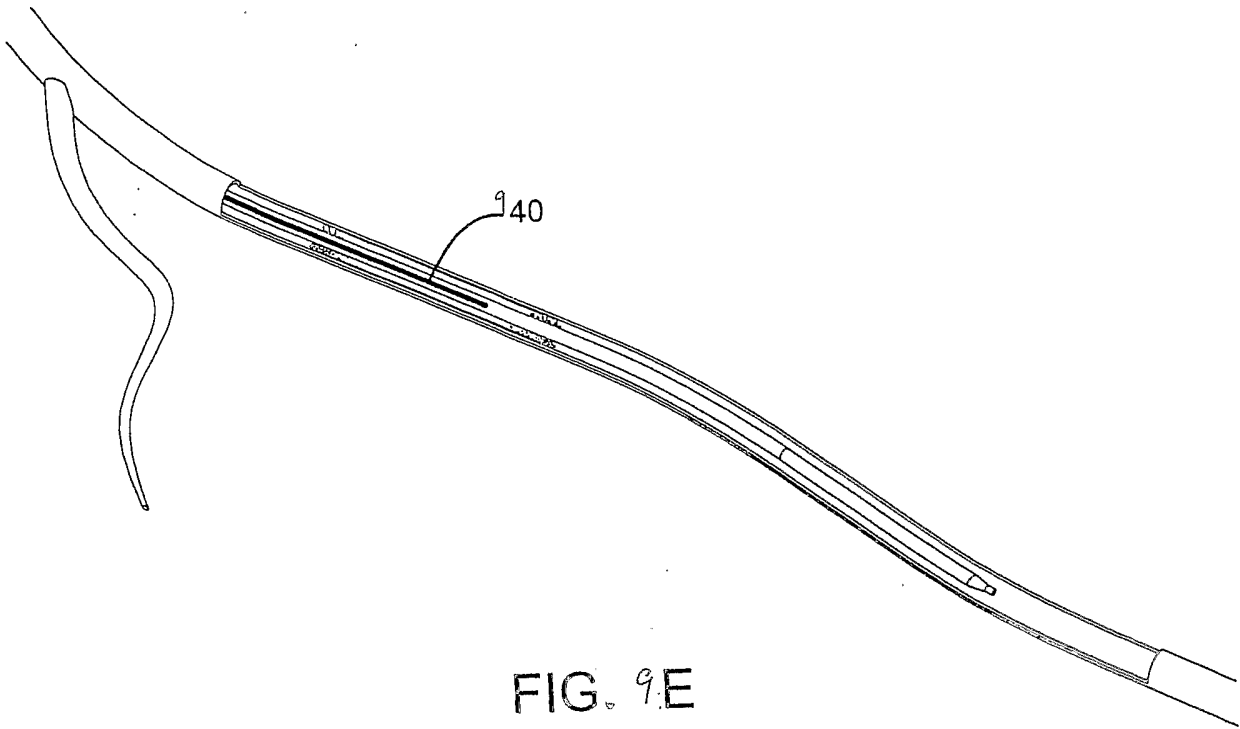

FIG. 9E

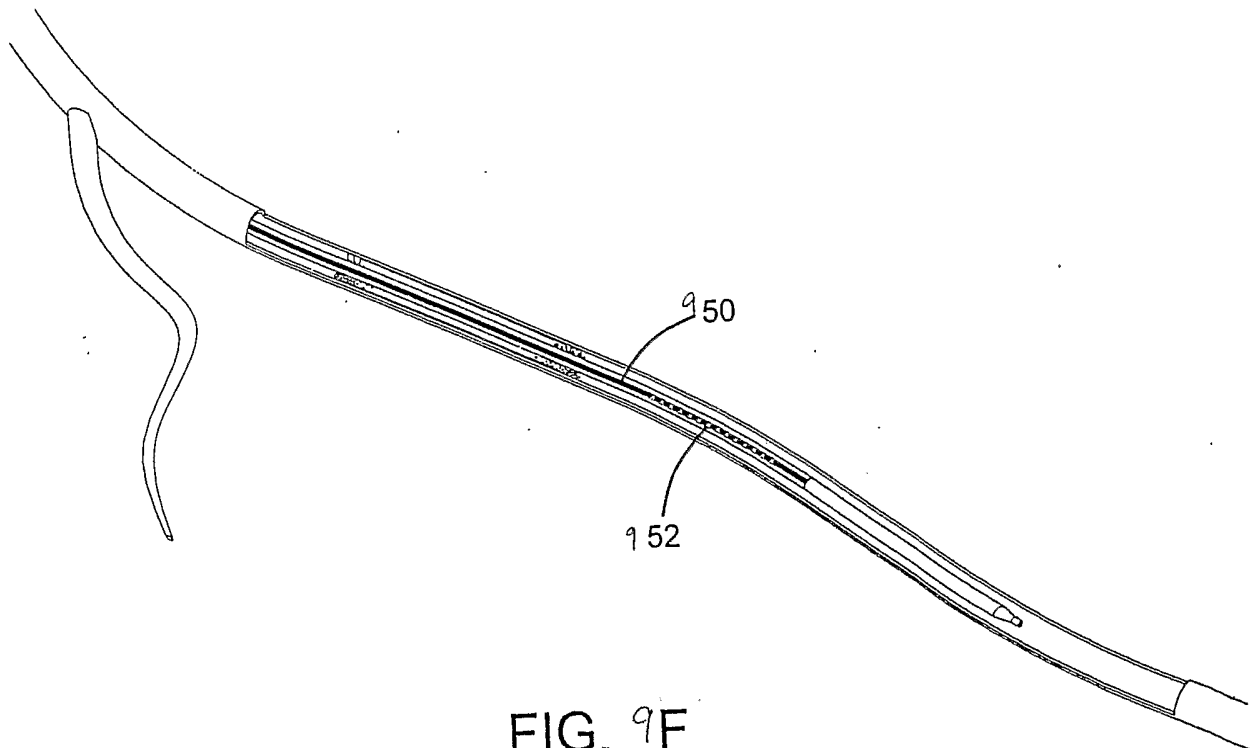
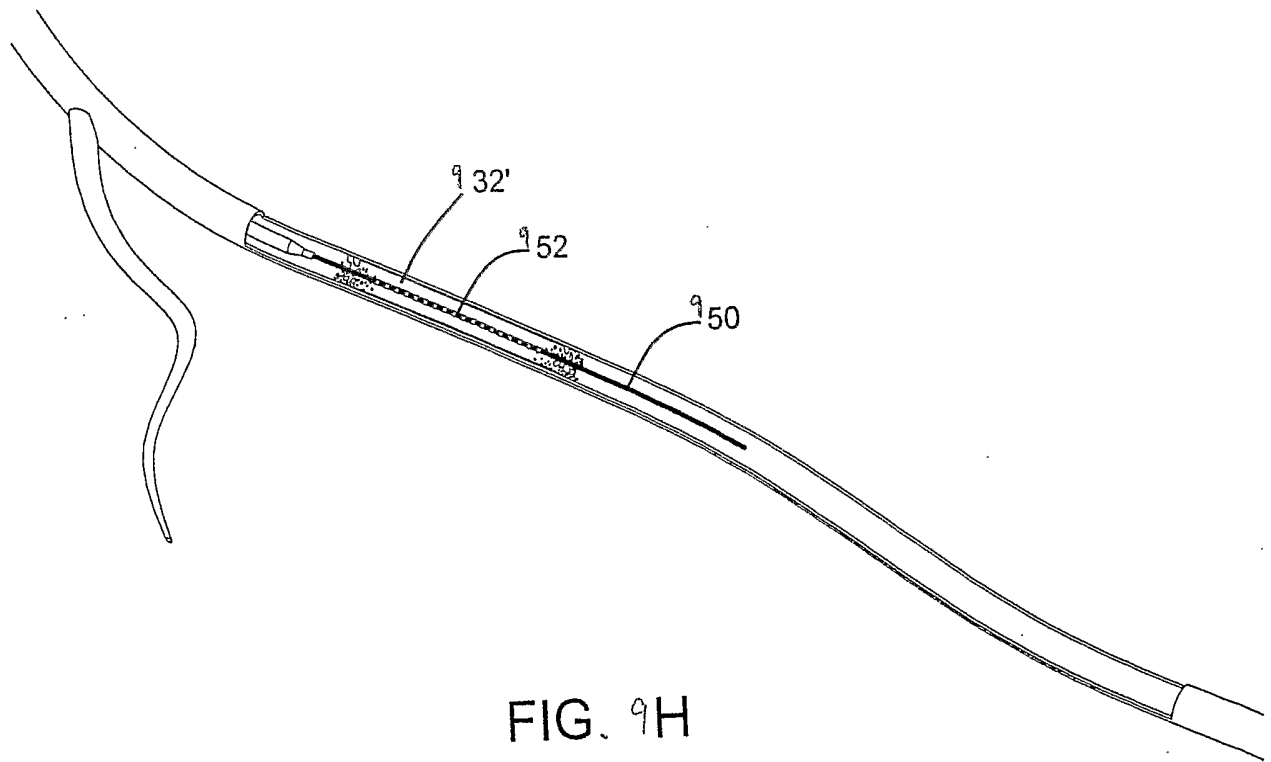
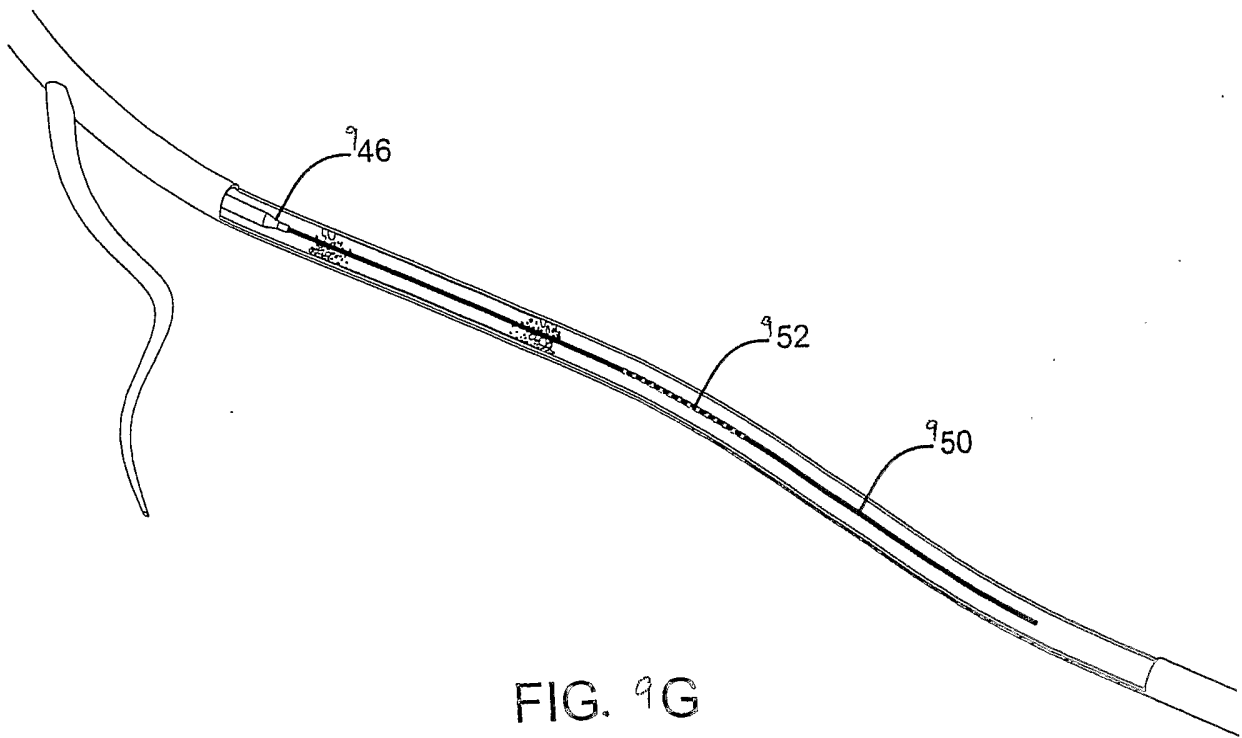

FIG. 9F



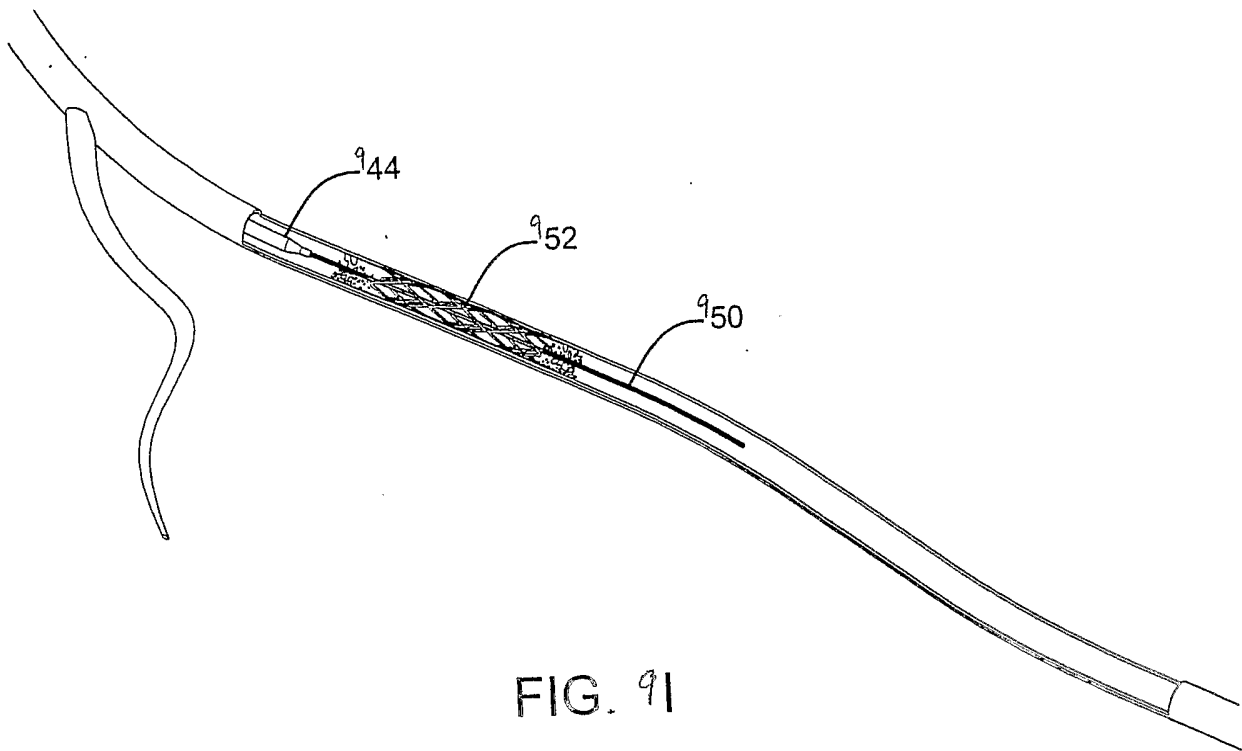

FIG. 9I

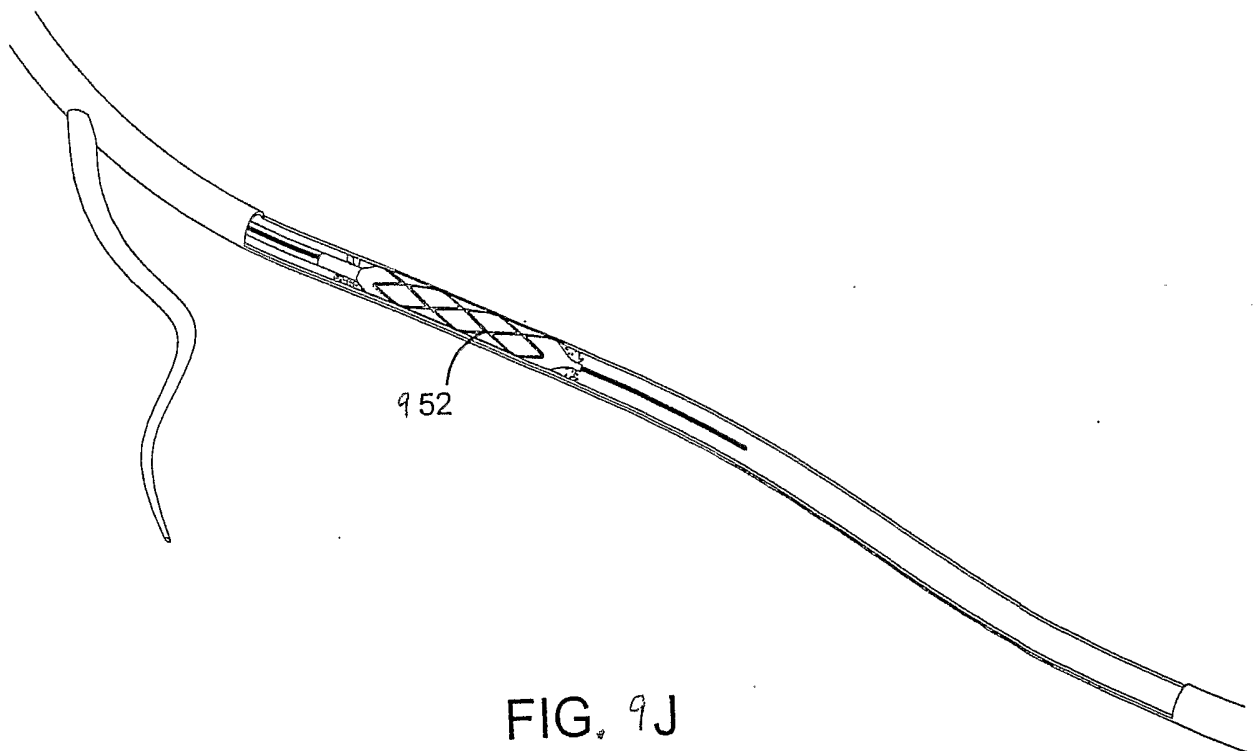

FIG. 9J

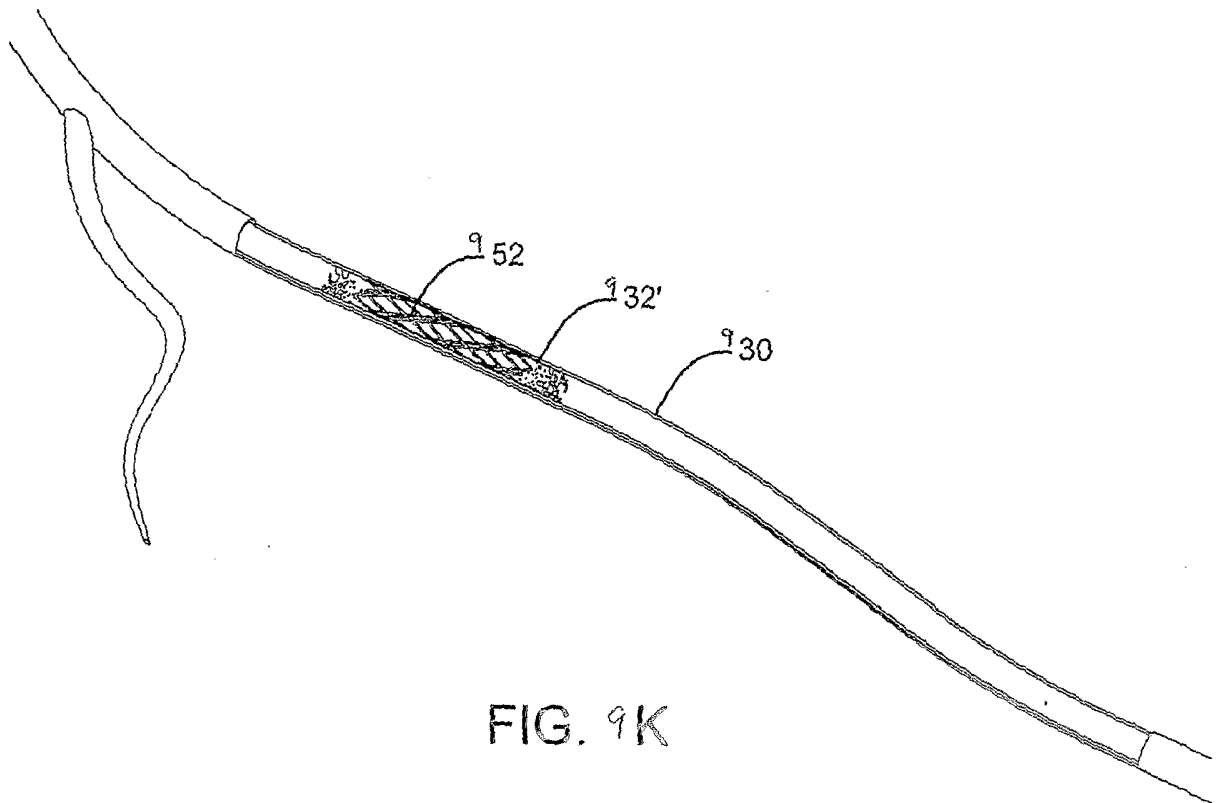

FIG. 9K

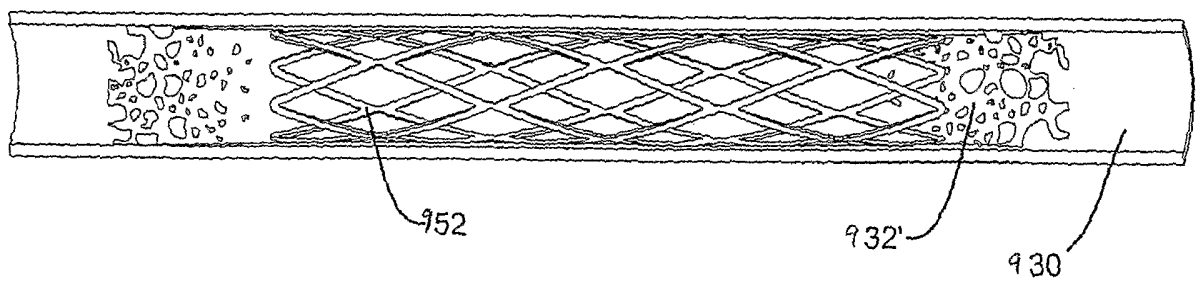
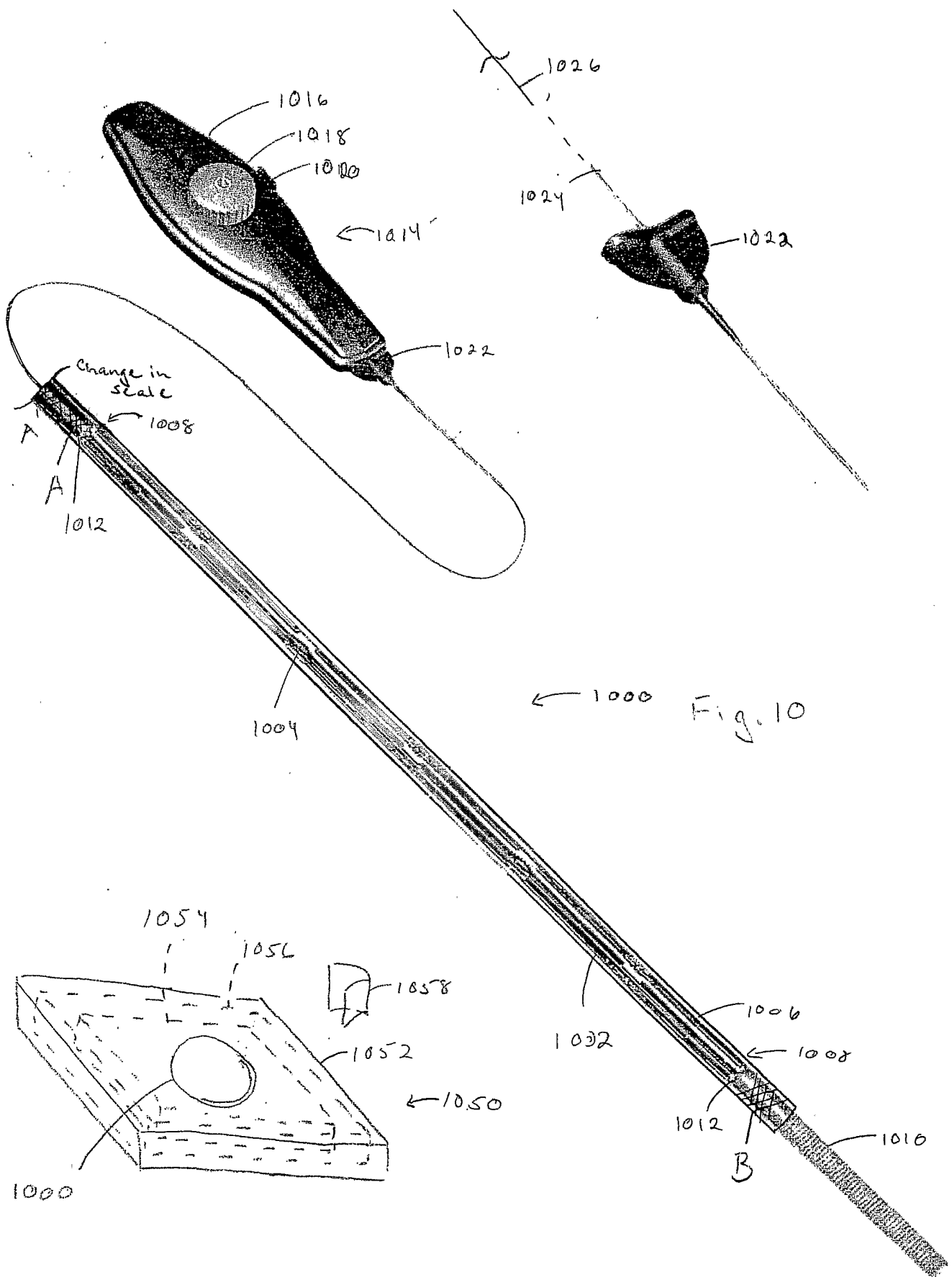

FIG. 9L



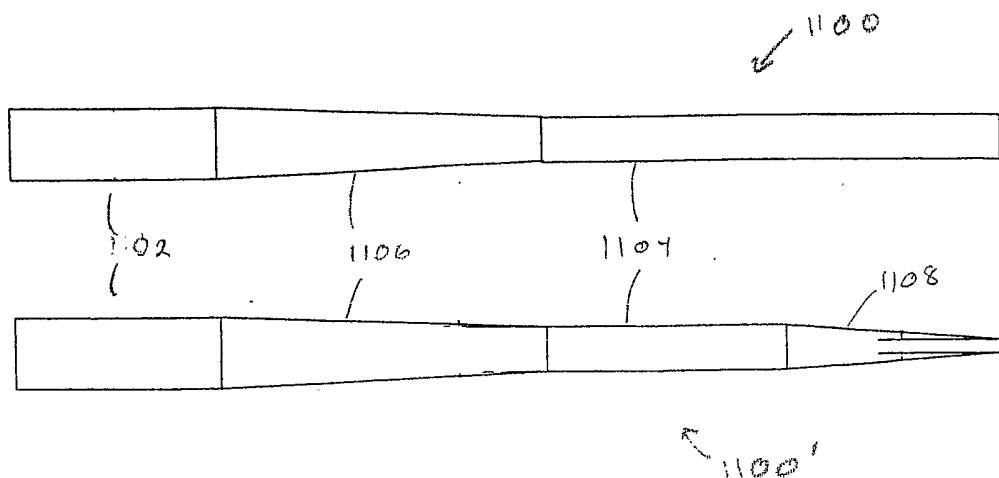

Fig. 11A

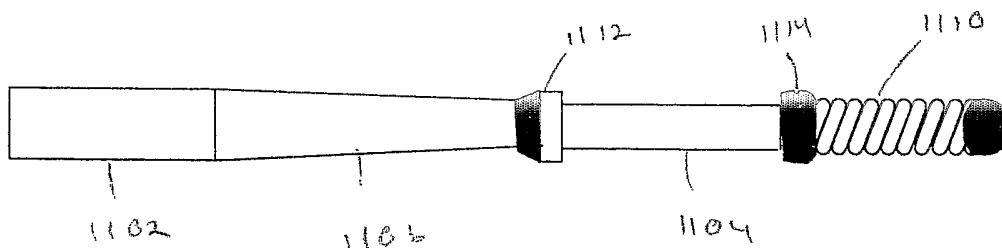

Fig. 11B

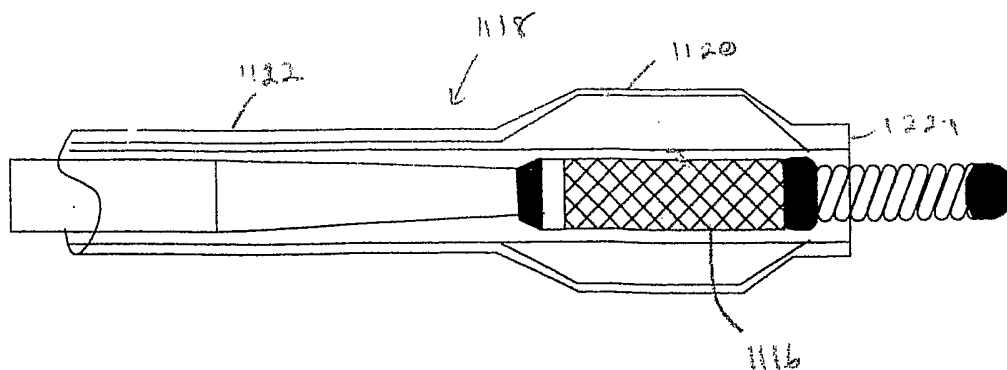

Fig. 11C

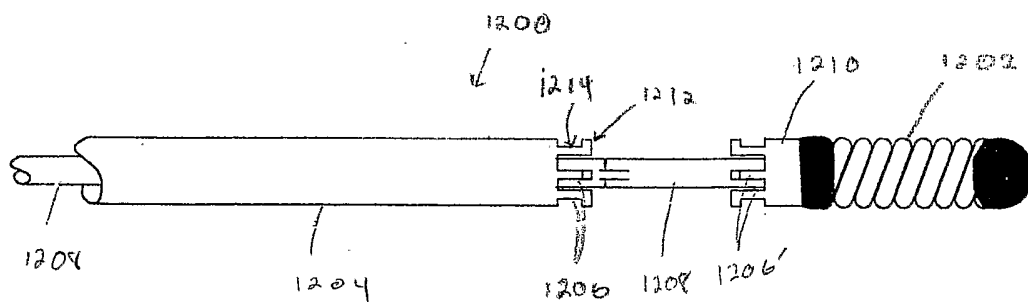

Fig. 12A

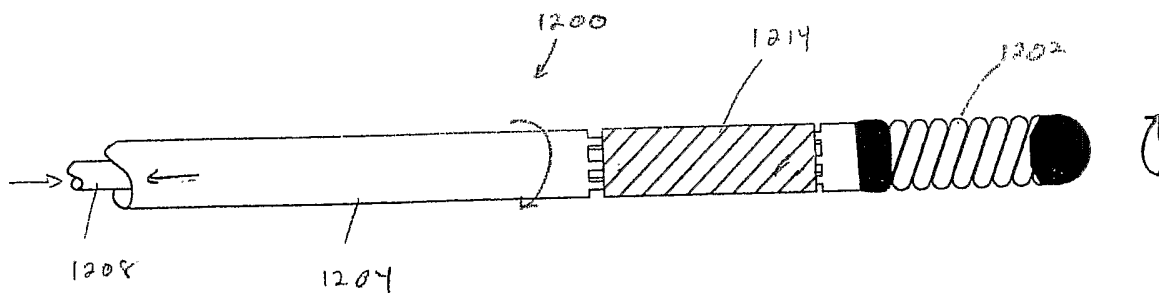

Fig. 12B

