

T. J. Powell,

Hay Elevator.

No. 103,367.

Patented May 24, 1870.

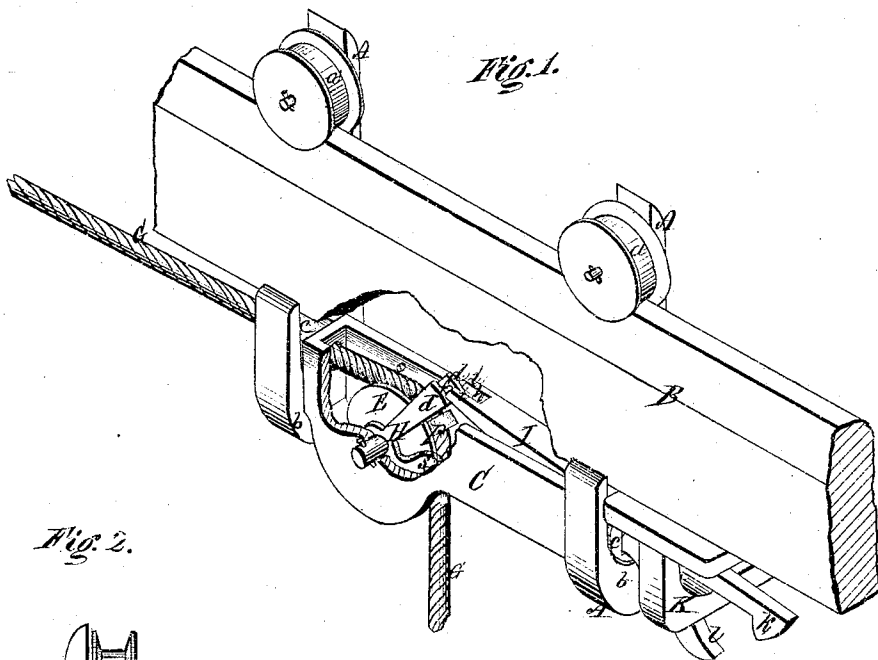

Fig. 2.

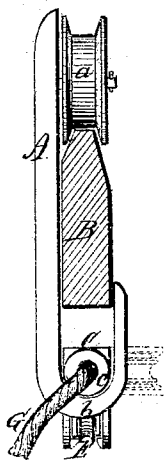
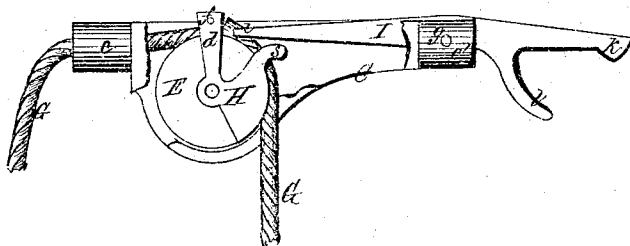

Fig. 3.



Witnesses:

C. C. Peck

Geo. W. Matt

Inventor:

Thomas J. Powell

By J. Fraser & Co  
Attorneys

# United States Patent Office.

THOMAS J. POWELL, OF NAPLES, NEW YORK.

Letters Patent No. 103,367, dated May 24, 1870.

## IMPROVED ELEVATOR AND CONVEYER.

The Schedule referred to in these Letters Patent and making part of the same.

To all whom it may concern:

Be it known that I, THOMAS J. POWELL, of Naples, in the county of Ontario and State of New York, have invented a certain new and useful Improvement in Combined Hay-Elevators and Conveyers, of which the following is a specification.

### Nature of Invention.

This invention consists in a swiveled bearing-block, hung in the car, having combined therewith the operating parts, as hereinafter described.

### General Description.

In the drawings—

Figure 1 is a perspective view of my improvement;

Figure 2, a sectional end elevation;

Figure 3, a view of the bearing-block and its operating parts detached.

A is the car, running on the wooden way B.

It has carrying-rollers *a a* at the top, and sockets *b b* at the bottom.

C is the bearing-block or frame, suspended in sockets *b b*, by means of circular bearings or journals *c c*. This connection allows the block to turn to either side, as will be hereafter described.

The block C is made hollow, for the purpose of receiving the operating parts.

A grooved pulley, E, is pivoted in the front end, over which passes the hoisting-rope or chain G, which then extends out through bearing *e*, which is made hollow for the purpose.

If desired, the end of the rope to which the load is attached may be run over one or more pulleys, to increase its power.

On the same axis with the pulley is situated a pawl, H, whose arms *d d* extend upward above the pulley, where they are connected by a cross-pin, *f*, or otherwise, with sufficient space for the hoisting-rope to run through between the pin and the pulley.

A lever, I, is pivoted at *g*, in the rear bearing of the block, its front end having a notch, *h*, therein, and its branches *i i* resting upon the ends of arms *d d*, when set, as shown in fig. 1.

The rear end of the lever is formed with a reverse hook, *k*, and arm *l*, which engage with a stop or catch, K, attached on the under side of the way at the starting and stopping point of the car, as will presently be described.

This stop-catch may be made either fixed rigidly to the way, or hinged to turn back, to allow the car to pass, or it may be made to slide on the way, as may be desired.

The action of the apparatus as above described, is as follows:

After the car has been discharged of its load, it is run

back over the way till hook *k* has passed into stop or catch K, and the arm *l* strikes the front of the same. This action depresses the hook, so as to engage with the stop or catch, while the front end of the lever is raised, and the arms *d d* fall, or are pressed back under it, thereby holding it elevated and locking the hook to the stop or catch, as shown in fig. 1.

The end of the hoisting-rope, to which the load is attached, is now lowered, and the load applied. The forward motion of the rope now elevates the load, and when the proper height is reached, the ring *p* on the rope strikes the pawl H, and draws the arms *d* from under the end of the lever. This disengages the hook from the stop or catch, and allows the car to move forward.

The same action makes the front end of the lever act as a pawl, holding the rope against the pulley, and preventing the load descending.

I am aware that disengaging levers, catches, and hoisting-ropes have before been used for a similar purpose, and, therefore, do not claim such broadly.

I believe my arrangement of the same to be new, however, especially the reverse hook and arm *k l*, and the notched end of the lever, acting in connection with the arms *d d* of the pawl.

A special feature of novelty consists in combining these parts with the swiveled bearing-block C, as described; this enables the whole to be hung in the sockets of the car, and to be removed and reversed in position at pleasure, so that it may be run in the opposite direction.

What is of more importance, however, is that the swiveled block can turn on its bearing ends to any side angle, as shown by dotted lines, fig. 2, so that, in drawing up from either end of the load beneath, the parts can adapt themselves to any angle, and prevent binding.

It also prevents any difficulty from the swinging of the load.

Furthermore, it enables the block to be changed to an opposite position, and run the other way on the track.

Where a sling is used in place of a fork, I dispense with the ring *p* on the rope, and make the load itself act in its place.

In this case I connect with the secondary arms *s s* of the pawl, a metallic rod, extending down a suitable distance, and having an eye in its lower end through which the rope runs.

When the load strikes this eye it elevates the rod, and, consequently, disengages the pawl from the hook lever.

It will be noticed that the stop or catch K is made circular, so that, as the block C inclines to any angle, the hook that engages with the stop or catch will fol-

low round in the circle of the same, and always keep its engagement therewith.

*Claims.*

What I claim, and desire to secure by Letters Patent, is—

1. The swiveled block C, holding the operating parts, and combined with the car in such a manner as to turn to any desired angle therein, as herein described; also, to be reversed in position.

2. The arrangement of the lever I with hook and arm *k l*, and pawl H with arms *d d*, the pulley E and

the hoisting-rope G, used either with or without the swiveled block C, in the manner and for the purpose specified.

3. The circular stop or catch K, when combined with a hook, *k*, and arm *l*, having an angular movement, as herein described.

In witness whereof I have hereunto signed my name in the presence of two subscribing witnesses.

THOMAS J. POWELL.

Witnesses:

GEO. W. MIATT,

R. F. OSGOOD.