



US 20040148703A1

(19) **United States**

(12) **Patent Application Publication**
Doering et al.

(10) **Pub. No.: US 2004/0148703 A1**

(43) **Pub. Date: Aug. 5, 2004**

(54) **OPERATING TABLE**

(30) **Foreign Application Priority Data**

Nov. 15, 2002 (DE)..... 102 53 846.8-45

(76) Inventors: **Ulrich Doering**, Saalfeld (DE);
Christian Streitberger, Saalfeld (DE);
Falk Georgi, Unterwirbach (DE)

Publication Classification

(51) **Int. Cl.⁷** **A47B 7/00**
(52) **U.S. Cl.** **5/610; 5/613**

Correspondence Address:
FISH & RICHARDSON P.C.
1425 K STREET, N.W.
11TH FLOOR
WASHINGTON, DC 20005-3500 (US)

(57) **ABSTRACT**

An operating table includes a bearing column, a table top mounted on the bearing column, and a control device. The table top is displaceable from a middle position transversely to a longitudinal axis of the table and tiltable about a tilting axis that is substantially parallel to the longitudinal axis of the table. The control device automatically activates a transverse displacement of the table top in a direction towards the middle position during a tilting movement.

(21) Appl. No.: **10/714,450**

(22) Filed: **Nov. 17, 2003**

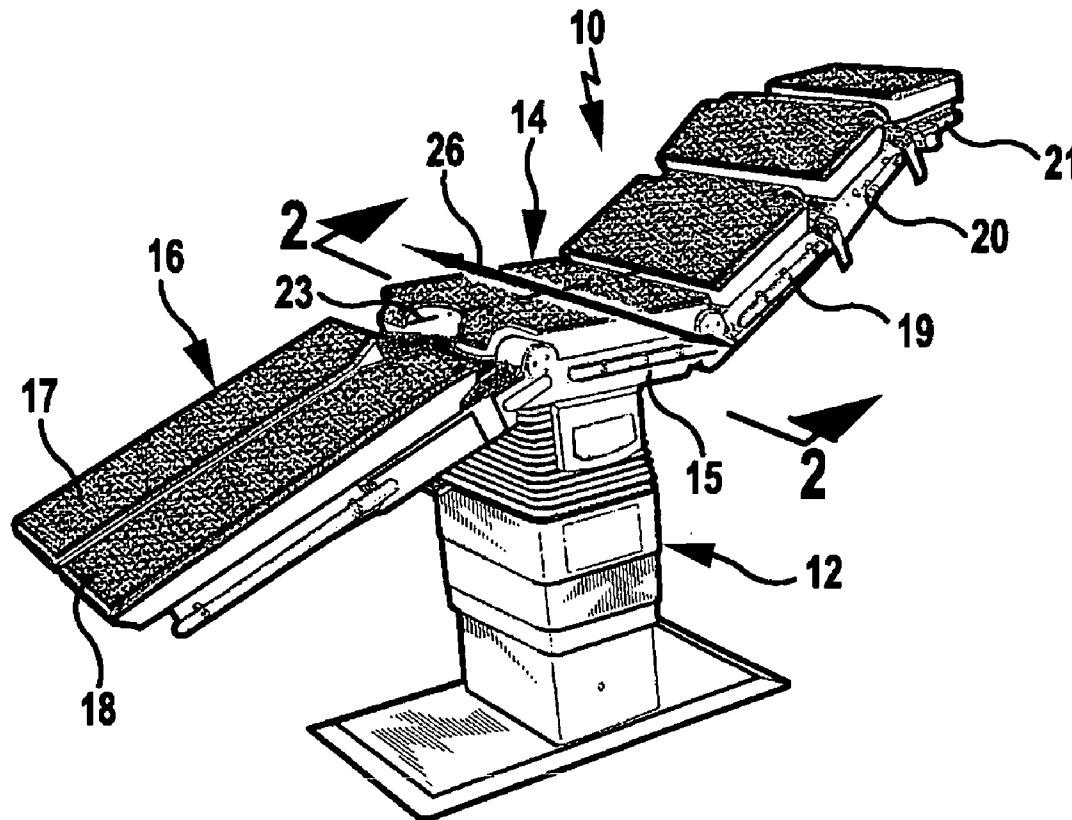

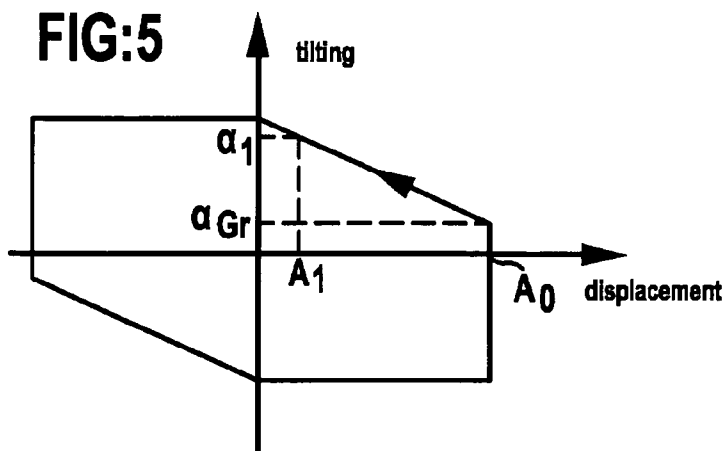
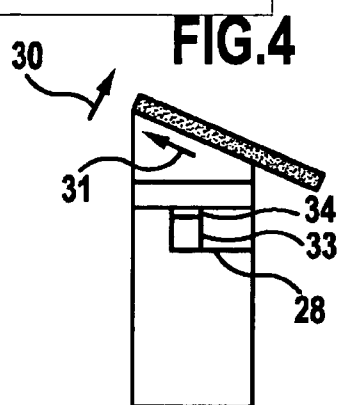
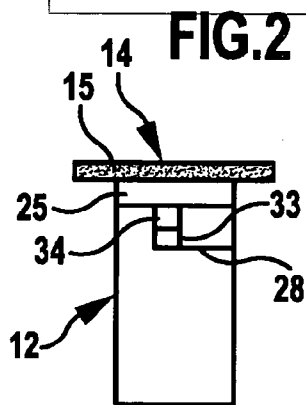
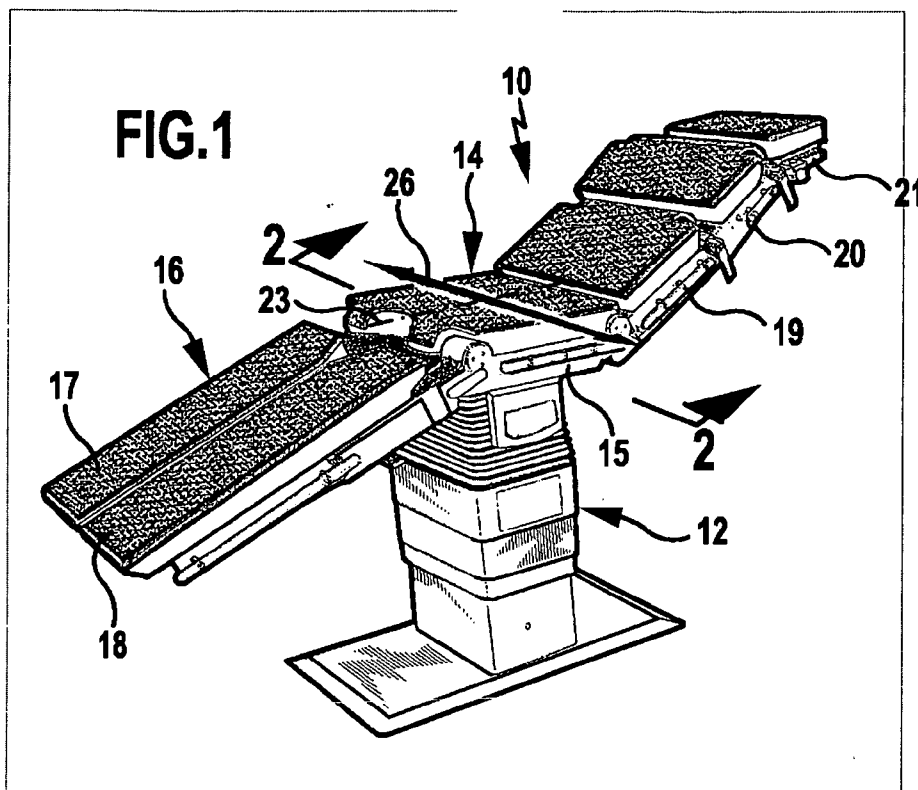

OPERATING TABLE

CLAIM OF PRIORITY

[0001] This application claims priority under 35 USC § 119(a) to German Patent application number No. 102 53 846.8-45, filed on Nov. 15, 2002, the entire contents of which are hereby incorporated by reference.

TECHNICAL FIELD

[0002] This disclosure relates to a device for supporting a patient, in particular, an operating table.

BACKGROUND

[0003] Tables for supporting a patient during an operation include a table top mounted on a bearing column with the table top being held on the bearing column. The table top is transversely displaceable relative to a longitudinal axis of the table from a middle position and tiltable about a tilting axis that is parallel to the longitudinal axis of the table. A patient can be placed on the table top, and the table top can be laterally outwardly displaced from the middle position transversely to the longitudinal direction of the table, for example, while fluoroscopy is being carried out on part of the patient's body. The table top can also be tilted about the tilting axis, so that, for example, the site of an operation can be made to face the operating surgeon.

[0004] If a laterally outwardly displaced table top is additionally tilted outwards, the table top in known operating tables projects to a great extent at the side, and the mechanical load thus acting to a large extent on one side of the operating table negatively influences the stability of the operating table. To counteract this danger, the extent of the tilting movement is restricted in dependence upon the displacement of the table top transversely to the longitudinal axis of the table. Thus, the table top, starting from its position of maximum lateral displacement, cannot be tilted at all, or only to a very slight extent, about a tilting axis extending parallel to the longitudinal axis of the table when the table top is transversely displaced from its middle position.

SUMMARY

[0005] A stable operating table is disclosed in which a table top of the operating table is automatically transversely displaceable during a tilting movement of the table top.

[0006] In a first general aspect, an operating table includes a bearing column, a table top mounted on the bearing column, and a control device. The table top is displaceable from a middle position transversely to a longitudinal axis of the table and tiltable about a tilting axis that is substantially parallel to the longitudinal axis of the table. The control device automatically activates a transverse displacement of the table top in a direction towards the middle position during a tilting movement.

[0007] The operating table may include one or more of the following features. The control device can automatically displace the table top in the direction of its middle position transversely to the longitudinal axis of the table when a predetermined critical angle is exceeded during a tilting movement. The critical angle can be predetermined as a function of the displacement of the table top from its middle

position transversely to the longitudinal axis of the table. The control device can include an electronic control unit. The control unit can include a comparator element for comparing an actual tilting angle with the predetermined critical angle. The control unit can include a computing element for calculating the predetermined critical angle as a function of the displacement of the table top transversely to the longitudinal axis of the table. The control unit can include a memory element for storing critical angle values as a function of the displacement of the table top.

[0008] In second general aspect, an operating table includes a bearing column, a table top mounted on the bearing column, where the table top is displaceable from a middle position transversely to a longitudinal axis of the table and tiltable about a tilting axis that is substantially parallel to the longitudinal axis of the table, and a means for automatically activating a transverse displacement of the table top in a direction towards the middle position during a tilting movement.

[0009] The operating table may include one or more of the following features. The means for automatically activating a transverse displacement of the table top can automatically displace the table top in the direction of its middle position transversely to the longitudinal axis of the table when a predetermined critical angle is exceeded during a tilting movement. The critical angle can be predetermined as a function of the displacement of the table top from its middle position transversely to the longitudinal axis of the table.

[0010] In a third general aspect, a method of supporting an operating table includes supporting a table top of the operating table on a bearing column, tilting the table top about a tilting axis that is substantially parallel to a longitudinal axis of the table, and automatically displacing the table top towards a middle position transversely to the longitudinal axis of the table during the tilting of the table top.

[0011] The method can include one or more of the following features. The table top can be automatically transversely displaced when a predetermined critical angle is exceeded during the tilting of the table top. The critical angle can be predetermined as a function of the displacement of the table top from its middle position transversely to the longitudinal axis of the table. The method can further include measuring a tilt angle of the table top. The method can further include comparing the measured tilt angle with a predetermined critical angle. The method can further include calculating the predetermined critical angle as a function of a displacement of the table top transversely to the longitudinal axis of the table. The method can further include storing values of predetermined critical angle values as a function of the displacement of the table top.

[0012] The details of one or more embodiments of the invention are set forth in the accompanying drawings and the description below. Other features, objects, and advantages of the invention will be apparent from the description and drawings, and from the claims.

DESCRIPTION OF DRAWINGS

[0013] FIG. 1 is a perspective illustration of an operating table.

[0014] FIG. 2 is a schematic sectional view taken along line 2-2 in FIG. 1, in which the table top of the operating table is in a middle position.

[0015] FIG. 3 is a schematic sectional view corresponding to FIG. 2, in which the table top is in a laterally displaced position.

[0016] FIG. 4 is a schematic sectional view corresponding to FIG. 2, in which the table top is in a position in which it is laterally displaced and tilted about a tilting axis that is parallel to a longitudinal axis of the table.

[0017] FIG. 5 is a schematic illustration of the correlation between a tilting movement and a transverse displacement of the table top.

[0018] Like reference symbols in the various drawings indicate like elements.

DETAILED DESCRIPTION

[0019] An operating table generally designated 10 in a perspective illustration in FIG. 1 includes a bearing column 12 that is adjustable in its height and supports a table top 14. The table top 14 is of a multipart design and includes a base segment 15 mounted on the bearing column 12.

[0020] A leg segment 16 with two leg plates 17 and 18 and a bottom back segment 19 are attached to the base segment 15 for swivel movement about a horizontal axis. The bottom back segment 19 serves as a swivel mount for a top back segment 20 on which a head plate 21 is attached for swivel movement. Alternatively, the table top 14 can be of one-part design. The connection of the table top 14 to the bearing column 12 can be of detachable or undetachable design.

[0021] The base segment 15 of the table top 14 is mounted on a column head 25 of the bearing column 12 for displacement transversely to the longitudinal axis 23 of the table, so that via the base segment 15 the entire table top 14 is laterally displaceable in the direction of double arrow 26 (i.e., transversely to a longitudinal axis 23 of the table top 14) starting from a middle position shown in FIG. 1 and FIG. 2. For this purpose, the base segment 15 includes a drive device in the form of an electric motor (not shown). An electronic control unit 28 integrated into the bearing column 12 is associated with the drive device.

[0022] The table top 14 is also tiltable about a tilting axis which is in parallel alignment with the longitudinal axis 23 of the table, as shown in FIG. 4. The column head 25 can be raised or lowered at one side by a lifting device (not shown) to achieve a tilted position of the table top 14. Any lifting device known for use with operating tables can be used.

[0023] When the table top 14 is displaced from its middle position as shown in FIG. 3 and is tilted about the tilting axis parallel to the longitudinal axis 23 of the table top 14 beyond a predetermined critical angle, the drive device integrated into the base segment 15 is activated by the control unit 28 to cause a lateral displacement of the table top 14. Thus, a transverse movement symbolized by arrow 31 in FIG. 4 is superimposed on the tilting movement of the table top 14 symbolized by arrow 30 in FIG. 4 to ensure that an unlimited tilting movement 30 can be carried out independently of the respective initial position of the table top 14.

[0024] The critical angle may be selected as a function of the displacement of the table top 14 from its middle position transversely to the longitudinal axis 23 of the table top. The greater the displacement, the smaller the critical angle,

which, when exceeded, causes an additional transverse movement of the table top to be superimposed on the tilting movement. The drive device can include a control cam and/or a control gearing for superimposing upon a tilting movement of the table top 14 a transverse displacement occurring in the direction of its middle position when the critical angle is exceeded.

[0025] The correlation between the prevailing lateral displacement of the table top 14 and the respective critical angle that, when exceeded, causes a transverse movement of the table top 14 opposite to the tilting movement, is represented in a coordinate system in FIG. 5. The greater the displacement of the table top 14 is at the start of the tilting movement, the smaller the critical angle. If the latter is exceeded, the table top 14 is automatically displaced in the direction of its middle position shown in FIG. 2, and the transverse displacement is effected until the desired tilted position is reached. If, however, a tilting movement is effected in the direction opposite to the lateral displacement of the table top 14, the tilting movement occurs without any additional transverse movement being activated. If, for example, starting from a maximum displacement A_0 , a tilting movement is to be effected in the direction facing away from the bearing column 12, the tilting angle α , starting from the value 0, then reaches the critical angle α_{Gr} corresponding to the displacement A_0 after a short time. If the critical angle α_{Gr} is exceeded as the tilting movement continues, this is recognized by a comparator element 33 of the control unit 28, which thereupon activates the drive unit integrated into the base segment 15, so that the table top is displaced transversely to the longitudinal axis 23 of the table in the direction of its middle position. The critical angle α_{Gr} associated with a prevailing displacement is determined in the control unit by a computing element 34 which precedes the comparator element 34. The superimposed tilting and transverse movement is effected until the table top has reached the desired tilting angle α_1 . The displacement of the table top 14 transversely to the longitudinal axis of the table was thereby reduced to the value A_1 . It is thus ensured that independently of the prevailing lateral displacement of the table top, a tilting movement does not affect the stability of the operating table 10.

[0026] The control unit 28 includes a comparator element for comparing an actual tilting angle of the table top 14 with the predetermined critical angle. A sensor can detect the actual tilted position of the table top and the detected angle is fed to the comparator element. If the comparator element detects that the actual tilting angle of the table top in the displaced position exceeds the predetermined critical angle, the comparator element delivers a control signal for activation of a drive unit to displace the table top 14 transversely to the longitudinal axis 23 of the table in the direction of its middle position.

[0027] The control unit 28 includes a computing element for calculating a predetermined tilting angle as a function of the displacement of the table top transversely to the longitudinal axis of the table. The computing element can be provided with an algorithm for calculating the critical angle as a function of the actual position of the table top transversely to the longitudinal axis of the table. Such an algorithm is readily derivable from the relationships between such factors as the dimensions of the table top 14, the

bearing column 12, the center of mass of the table top, and the location of the tilting axis.

[0028] Alternatively, the control unit 28 can include a memory element for storing critical angle values that are a function of the displacement of the table top 14 transversely to the longitudinal axis 23 of the table. When manufacturing the operating table, it is thus possible to deposit in the memory element critical angle values as a function of the lateral displacement of the table top, which can be requested during operation of the operating table 10 and compared with an actual tilting angle of the table top.

OTHER EMBODIMENTS

[0029] A number of embodiments of the invention have been described. Nevertheless, it will be understood that various modifications may be made. Accordingly, other embodiments are within the scope of the following claims.

What is claimed is:

- 1. An operating table comprising:
 - a bearing column;
 - a table top mounted on the bearing column, wherein the table top is displaceable from a middle position transversely to a longitudinal axis of the table and tiltable about a tilting axis that is substantially parallel to the longitudinal axis of the table; and
 - a control device that automatically activates a transverse displacement of the table top in a direction towards the middle position during a tilting movement.
- 2. The operating table of claim 1, wherein the control device automatically displaces the table top in the direction of its middle position transversely to the longitudinal axis of the table when a predetermined critical angle is exceeded during a tilting movement.
- 3. The operating table of claim 2, wherein the critical angle is predetermined as a function of the displacement of the table top from its middle position transversely to the longitudinal axis of the table.
- 4. The operating table of claim 3, wherein the control device comprises an electronic control unit.
- 5. The operating table of claim 4, wherein the control unit comprises a comparator element for comparing an actual tilting angle with the predetermined critical angle.
- 6. The operating table of claim 5, wherein the control unit comprises a computing element for calculating the predetermined critical angle as a function of the displacement of the table top transversely to the longitudinal axis of the table.
- 7. The operating table of claim 5, wherein the control unit comprises a memory element for storing critical angle values as a function of the displacement of the table top.

- 8. An operating table comprising:
 - a bearing column;
 - a table top mounted on the bearing column, wherein the table top is displaceable from a middle position transversely to a longitudinal axis of the table and tiltable about a tilting axis that is substantially parallel to the longitudinal axis of the table; and
 means for automatically activating a transverse displacement of the table top in a direction towards the middle position during a tilting movement.
- 9. The operating table of claim 9, wherein the means for automatically activating a transverse displacement of the table top automatically displaces the table top in the direction of its middle position transversely to the longitudinal axis of the table when a predetermined critical angle is exceeded during a tilting movement.
- 10. The operating table of claim 10, wherein the critical angle is predetermined as a function of the displacement of the table top from its middle position transversely to the longitudinal axis of the table.
- 11. A method of supporting an operating table, the method comprising:
 - supporting a table top of the operating table on a bearing column;
 - tilting the table top about a tilting axis that is substantially parallel to a longitudinal axis of the table; and
 - automatically displacing the table top towards a middle position transversely to the longitudinal axis of the table during the tilting of the table top.
- 12. The method of claim 11, wherein the table top is automatically transversely displaced when a predetermined critical angle is exceeded during the tilting of the table top.
- 13. The method of claim 12, wherein the critical angle is predetermined as a function of the displacement of the table top from its middle position transversely to the longitudinal axis of the table.
- 14. The method of claim 13, further comprising measuring a tilt angle of the table top.
- 15. The method of claim 14, further comprising comparing the measured tilt angle with a predetermined critical angle.
- 16. The method of claim 15, further comprising calculating the predetermined critical angle as a function of a displacement of the table top transversely to the longitudinal axis of the table.
- 17. The method of claim 15, further comprising storing values of predetermined critical angle values as a function of the displacement of the table top.

* * * * *