

No. 756,037.

PATENTED MAR. 29, 1904.

A. MORRISON & A. MORLOCK.
PRESS RACK.

APPLICATION FILED MAR. 21, 1903.

NO MODEL.

Fig. 1.

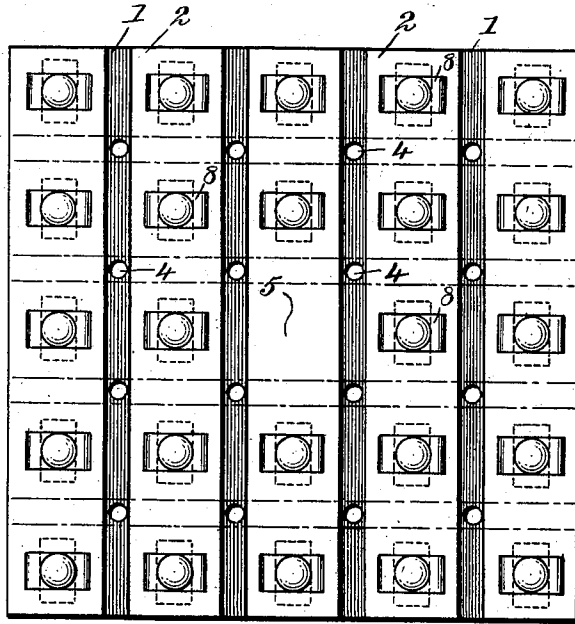
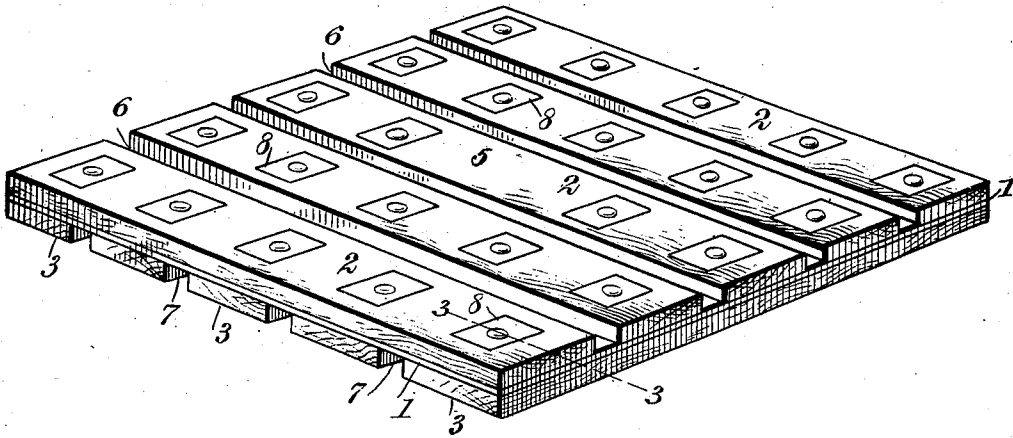
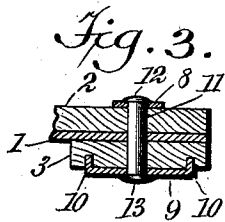

Fig. 2.



WITNESSES:

W. R. Appleman
Walton Harrison

INVENTORS
Angus Morrison
Albert Morlock
BY
Munn & Co.
ATTORNEYS.

UNITED STATES PATENT OFFICE.

ANGUS MORRISON, OF PHILADELPHIA, PENNSYLVANIA, AND ALBERT MORLOCK, OF NEW YORK, N. Y.

PRESS-RACK.

SPECIFICATION forming part of Letters Patent No. 756,037, dated March 29, 1904.

Application filed March 21, 1903. Serial No. 148,880. (No model.)

To all whom it may concern:

Be it known that we, ANGUS MORRISON, a resident of Philadelphia, in the county of Philadelphia and State of Pennsylvania, and ALBERT MORLOCK, a resident of the city of New York, borough of Brooklyn, in the county of Kings and State of New York, citizens of the United States, have invented new and useful Improvements in Press-Racks, of which the following is a full, clear, and exact description.

Our invention relates to press-racks of the type used in compressing substances such as seeds of various kinds, oily meal, offal, garbage, &c.

Our invention relates more particularly to the production of a simple, strong, and efficient form of press-rack which will stand rough usage and which is easily replaced either in part or as a whole.

Reference is to be had to the accompanying drawings, forming a part of this specification, in which similar characters of reference indicate corresponding parts in all the figures.

Figure 1 is a perspective view showing one of our racks ready for use. Fig. 2 is a plan view of the same, and Fig. 3 is a fragmentary section upon the line 3 3 of Fig. 1.

A plate 1, of metal, is provided with a plurality of slats 2, preferably of wood, placed upon its upper surface and disposed in the general direction shown, and a plurality of other slats 3, also preferably of wood, disposed upon the under side of the plate 1 and forming a right angle with the slats 2. The plate 1 is provided with holes 4, disposed in rows forming an angle with each other, as indicated in Fig. 2.

The slats 2 are spaced apart, so that each hiatus 6 is in alinement with a row of holes 4, extending in one general direction. Similarly the slats 3 are spaced apart, so that each hiatus 7 is disposed in alinement with a row of holes 4, extending in a general direction at right angles with the row first mentioned. Mounted upon each slot are the bearing-caps 8 9, provided with claws 10, as indicated in Fig. 3, the caps being connected rigidly together by means of rivets 11, upset at their

ends, as shown at 12 and 13. As the claws bite into the slats and secure a firm grip, the parts are held together very securely and the rack is not liable to be broken. It will be noticed that the central portion of the rack is not provided with a rivet. This arrangement is for the purpose of strengthening the rack. We have found this arrangement to be preferable for the reason that the central portion of the rack is subjected to great strain.

We do not limit ourselves to the use of the particular form of fastening member shown. Any other form of fastening member may be employed.

Having thus described our invention, we claim as new and desire to secure by Letters Patent—

1. A press-rack, comprising a flat plate of metal provided with rows of holes disposed in two directions crossing each other, and slats mounted upon said plate and disposed in two directions crossing each other, each slat being disposed between two consecutive rows of holes.

2. A press-rack, comprising a plate of metal, slats mounted upon both faces thereof, and fastening members connecting said slats and said plate together, said fastening members being disposed comparatively near the edges of said plate so that no fastening member appears adjacent to the center thereof.

3. A press-rack, comprising a plate of metal provided with a plurality of slats mounted upon each face thereof and spaced apart, the slats upon one of said faces forming an angle with the slats upon the other face thereof.

4. A press-rack, comprising a plate of metal provided with holes so disposed as to form rows in two directions, and a plurality of slats mounted upon said plate and spaced apart, said slats being disposed intermediate of said holes, and extending in two directions.

5. A press-rack, comprising a plate of metal, slats mounted thereon and spaced apart, rivets passing through said slats and said plate, and bearing-caps engaging said slats and said rivets.

6. A press-rack, comprising a plate of metal,

slats mounted thereon and spaced apart, said slats being disposed in two directions forming an angle with each other, rivets passing through said slats and said plate, longitudinal bearing-caps engaging said slats and said rivets, said bearing-caps being provided with claws and disposed crosswise of the general length of said slats with which they are severally in engagement.

7. A press-rack comprising a flat plate of metal, a plurality of longitudinal slats mounted upon each face thereof and spaced apart, said slats being disposed in two directions forming angles with each other, rivets passing through said plate and said slats, and longitudinal bearing-caps connected with said rivets and engaging said slats, said longitudinal bearing-

caps extending crosswise of the general length of said slats.

8. A press-rack, comprising a plate of metal, a plurality of slats mounted thereon, and rivets engaging said slats and said plate, said rivets being disposed comparatively near the edge of said plate thereby leaving a space not provided with rivets in the center of said plate.

In testimony whereof we have signed our names to this specification in the presence of two subscribing witnesses.

ANGUS MORRISON.
ALBERT MORLOCK.

Witnesses:

JNO. M. RITTER,
WALTON HARRISON.