

Sept. 10, 1935.

J. W. REED

2,014,291

MINERAL SEPARATOR

Filed April 28, 1934

2 Sheets-Sheet 1

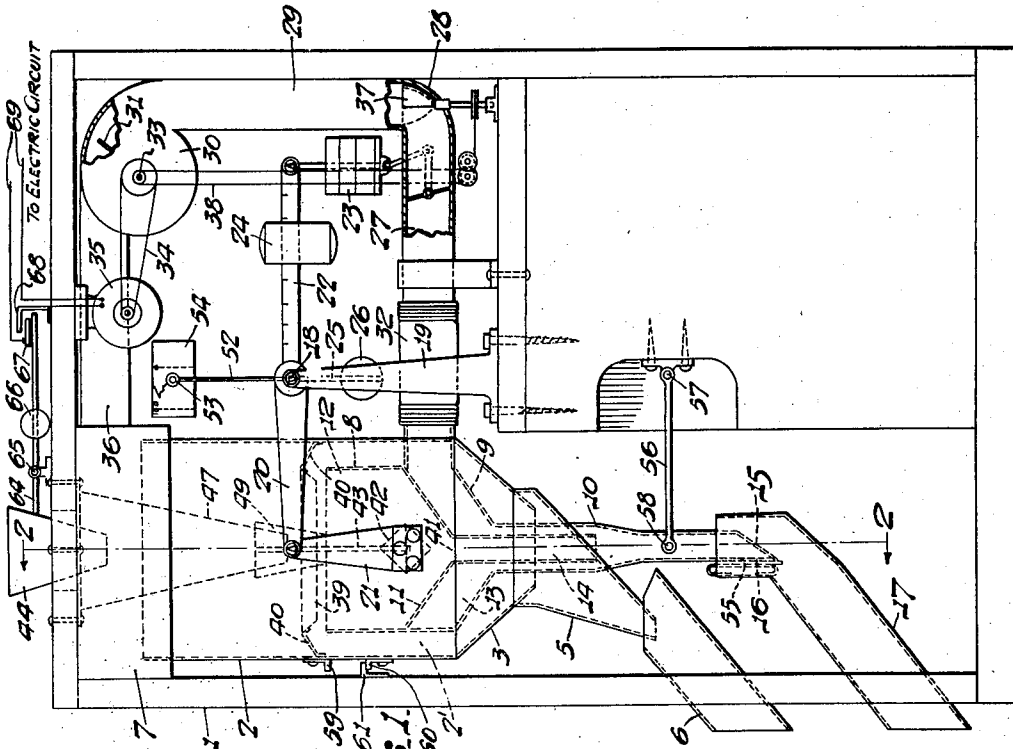

Fig. 1.

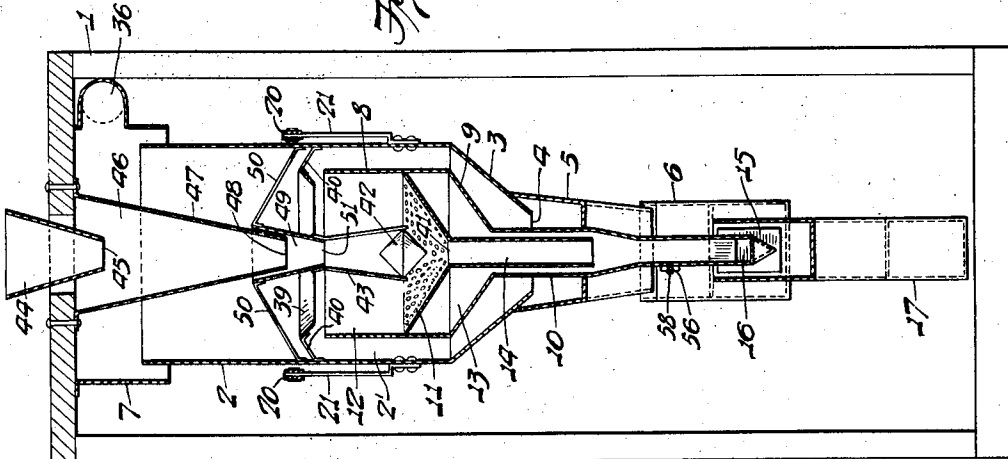

Fig. 2.

Inventor

Joseph W. Reed

By Morris & Bateman

Attorney

Sept. 10, 1935.

J. W. REED

2,014,291

MINERAL SEPARATOR

Filed April 28, 1934

2 Sheets-Sheet 2

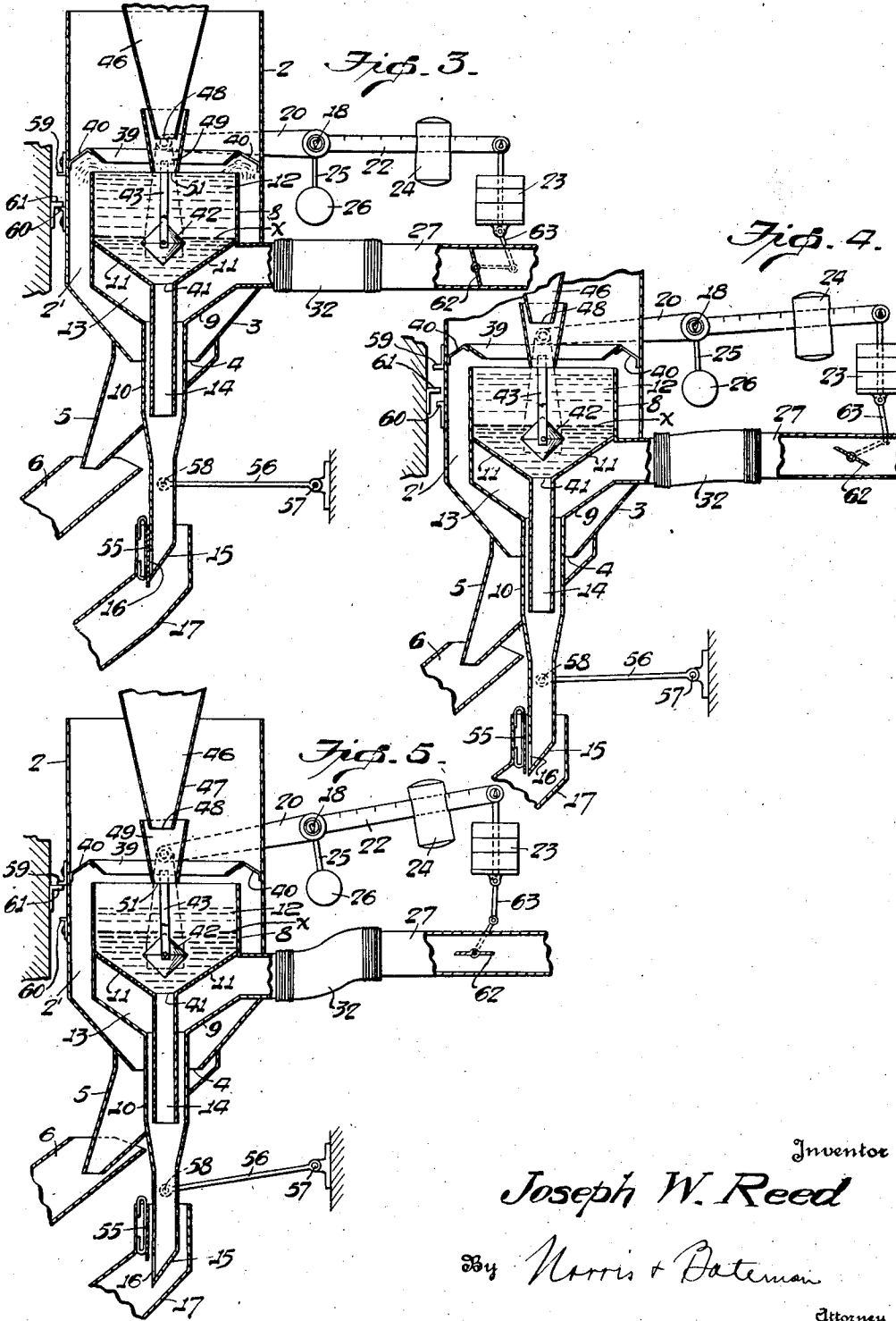

Inventor

Joseph W. Reed

By Norris + Bateman

Attorney

UNITED STATES PATENT OFFICE

2,014,291

MINERAL SEPARATOR

Joseph W. Reed, Fairmont, W. Va.

Application April 28, 1934, Serial No. 722,950

18 Claims. (Cl. 209—475)

My invention relates to ore or mineral separators and particularly to that class of separators wherein pulverized or granular ore is acted upon by jets or puffs of air, or other fluid in such a manner as to separate the lighter from the heavier grains, the lighter portions being carried to the top, allowing the heavier grains to settle to the bottom.

A device of this character comprises generally a separator chamber having a perforated bottom, means for feeding the material thereto, means for projecting jets or puffs of air or other fluid upwardly through the perforated bottom to stratify the material resting on said bottom, the lighter material being carried to the top, allowing the heavier material to settle to the lower stratum; and means for conducting the heavier and lighter portions from the device through separate channels. Such a device is efficient when designed and proportioned to handle or of a uniform richness and constant specific gravity of its component parts, but does not accommodate itself to variations in the specific gravity or richness of the ore.

Pulverized ore, generally speaking, consists of valuable portions which are usually of a greater specific gravity, and particles of a lighter specific gravity which have little or no value. In practice, the proportions of the heavier and lighter parts of the ore vary; and therefore, in order that the separate valuable portion of the ore shall be of uniform richness, means must be provided for automatically compensating for the variations in richness of the ore as it passes through the machine. Furthermore, the ores to be operated upon will vary in their known or expected specific gravity or richness, and therefore, means should be provided for initially determining the said richness, and for adjusting the device to operate on the same to the desired degree of perfection.

The object of this invention is to provide a device of the class mentioned by means of which the valuable portions of the ore may be delivered in a uniform degree or percentage of richness, irrespective of any variations in the richness of the ore.

A further object of this invention is to provide in a device of the class mentioned, means for initially determining and recording the richness of the ore being fed thereto.

A further object of the invention is to provide means for adjusting or regulating the device in accordance with the determined specific gravity or richness of the ore, so that it shall continue

to operate upon the ore to separate the valuable portions at a desired degree of richness or perfection.

A further object of the invention is to provide means whereby when the device is set to operate on an ore of known or expected richness, it will automatically adjust self to varying characteristics of the ore, both as to richness and density, so as to deliver the heavier particles proportionately to their rate of accumulation.

A further object of my invention is to provide a device of the class mentioned, means whereby the varying richness, determined by its specific gravity, will be continually recorded during the operation of the device.

A further object of the invention is to provide means for preventing the lighter portions of material from entering the discharge conduit provided for the heavier portions.

A further object of the invention is to provide means for automatically relieving the air pressure in the air chamber and consequently the degree of agitation, upon the accumulation of an excess of lighter material in the separator.

A further object of my invention is to provide a construction and arrangement of parts whereby the degree of agitation in the separator chamber shall be automatically varied in proportion to the volume accumulated therein.

A further object of the invention is to provide means whereby the device will automatically start into operation when the ore is fed thereto and which will stop when the feeding of the ore ceases. Other objects will appear hereinafter.

With these objects in view my invention consists generally in mounting the separating chamber and related parts for limited vertical movement due to the weight of the material therein, together with means associated and movable therewith for determining the specific gravity of the material fed thereto. Preferably the separating mechanism is mounted upon a balance beam having a tare weight to counterbalance the same. The means for determining the specific gravity of the ore as it is fed to the device comprises a compensating chamber supported above the separating chamber and having sloping sides and open at the bottom, means for delivering material to the compensating chamber in a uniform degree of compactness, and a pendulum connected to the beam to hold the device at rest after having moved to a position due to the weight of material in the compensating chamber. The invention further contemplates the provision of a recording device in com-

ination with the above arrangement whereby the attendant for the machine may at a glance determine the specific gravity of the material being fed to the machine at any time.

5 My invention further consists in providing a device as above mentioned, further characterized by a compensating chamber above the separator chamber and movable therewith and a feed chamber directly above the compensating chamber and having its lower end extending into the latter, said feed chamber having steeply sloping sides so as to deliver the pulverized ore to the compensating chamber in a uniform degree of compactness. My invention further consists in a
10 device as mentioned in which the compensating chamber and the feed chamber are both hopper shaped with steeply inclined walls and provided with discharge orifices at their lower ends, the discharge orifice of the compensating chamber
15 being smaller than the orifice of the feed chamber whereby a quantity of material of uniform compactness is maintained within the compensating chamber to the level of the feed chamber orifice.

25 The invention further includes an adjustable counterpoise for the balance beam whereby the device may be set to split the ore at the desired degree of richness. My invention further consists in a separator of the character under consideration having means for supplying agitating fluid thereto in jets or puffs, said means including a motor driven fan, in combination with a counterpoised tilting feed hopper, adapted when tilted by the presence of material therein
30 to close a circuit to the fan motor, and to open said circuit when free of material. My invention further consists in a device as mentioned in which the separator chamber is provided with a centrally disposed discharge orifice for the heavier material, communicating with a depending discharge conduit, in combination with means supported within the separator chamber to prevent the lighter portions of the material from entering said discharge conduit. My invention
35 further consists in such a combination and arrangement of parts that the accumulation of heavier material in the discharge conduits constitutes a valve for maintaining the air pressure in the air chamber, and which, when said material is discharged due to the augmented weight of material, will permit escape of a portion of the air so as to vary the air pressure in said air chamber. My invention further consists in a device
40 as mentioned in which the lower end of the discharge conduit from the separator chamber is provided with a normally closed valve, said valved end being opened more or less according to the volume of material of heavier specific gravity in the device.

60 My invention further consists in various details of construction and arrangements of parts all as will be fully described hereinafter and particularly pointed out in the claims.

65 My invention will be more readily understood by reference to the accompanying drawings forming a part of this specification and in which—

70 Figure 1 is a side elevation of a separating device embodying my invention in its preferred form, parts being shown in section,

Fig. 2 is a vertical section on substantially the line 2—2 of Fig. 1, and

75 Figs. 3, 4 and 5 are detail illustrations of the separator chamber illustrating the different posi-

tions thereof relative to the accumulation of material therein.

Referring now to the drawings, 1 indicates generally a housing for the apparatus which may be of any desired form so as to properly support the various parts and to protect the movable portions from outside influences. 2 indicates the outer casing of the separator which is provided with a hopper bottom 3 having a central discharge opening 4 communicating with a chute 5 fixed to said bottom. The chute 5 empties into a fixed discharge chute 6 extending through the side of the housing 1. The upper end of the casing 2 is open and extends into a dust hood 7 fixed within the upper portion of the housing, 15 as will be more fully described hereinafter.

Supported in a suitable manner within the lower portion of the casing 2 is a separator cup 8 having a hopper bottom 9 terminating in a vertical, centrally disposed tubular discharge conduit 10. The separator cup is of less diameter than the casing 2 and is centrally disposed within the same, thereby forming an annular space 2' between them, which constitutes a passageway for the lighter portions of the ore as they are discharged from the cup 8. A perforated plate 11 is arranged within the cup 8 and divides the same into an upper separating chamber 12 and a lower air chamber 13. The plate 11 is hopper shaped and empties into a central vertically disposed conduit 14, which extends concentrically into the upper end of the conduit 10. The conduit 10, below the lower end of conduit 14, is somewhat contracted in cross section and terminates in a trough shaped bottom 15, which 35 directs any material accumulating therein to a lateral discharge orifice 16 formed in the side of the conduit 10 at its lower end. This orifice at its upper end is substantially the width of the conduit and tapers downwardly in conformity with the trough shaped bottom 15 to facilitate the discharge therefrom. The lower end of the conduit 10 extends into a discharge chute 17 which chute extends through the side of the housing, 45 as indicated in Fig. 1.

The casing 2 and its contained parts are supported for limited vertical movement, as by a balance beam mounted upon a fulcrum shaft 18 having bearings in suitable brackets 19. One arm of the beam comprises a yoke 20, the free ends of the yoke being connected to lugs 21 fixed to the sides of the casing. The other arm of the beam comprises a graduated bar 22, and suspended from the end of the bar is a tare weight 23 for balancing the weight of the casing 2 and its contained parts. Slidably mounted on the graduated arm 22 is a counterpoise 24; and depending vertically from the fulcrum shaft 18 is a pendulum comprising a rigidly fixed arm 25 and a pendulum weight 26 adjustably mounted thereon. 60 The purpose of the counterpoise 24 and pendulum will be described hereinafter.

Communicating with the air chamber 13 and extending through the side of the casing 2 is an air duct 27 which extends horizontally to an elbow 28 and then upwardly as at 29 to a fan casing 30 of a pressure fan 31. Interposed in the horizontal portion of the air duct, and preferably adjacent the casing 2, is a flexible section 32 70 which permits vertical movement of the casing and its contained parts. The shaft 33 of the fan is connected, as by a belt 34, with a motor 35. The fan casing 30 is preferably arranged adjacent the top of the main housing 1, and an 75

air inlet duct 36 connects the same with the dust hood 7. This arrangement minimizes the amount of dust which escapes from the machine. It is obvious that when the fan is in operation, air under pressure is maintained in the chamber 13 and therefore jets of air are projected upwardly through the perforations in the plate 11 which constitutes the bottom of the separating chamber. To properly agitate the material resting on the perforated bottom, these jets of air should be in intermittent puffs; and to this end, suitable means are provided for interrupting the passage of air through the air duct to a sufficient degree to produce this pulsating effect. The interrupter comprises a half cup shaped valve 37 mounted to rotate within the elbow 28 of the air duct. This valve is driven from the fan shaft 33 by suitable belting 38.

In operating the device, pulverized ore or mineral is fed in a continuous stream to the separator chamber where it rests upon the perforated bottom 11 and is subjected to the jets or puffs of air above mentioned. Such action of the air agitates the pulverized material and stratifies the same, causing the lighter particles to rise to the top and permitting the heavier particles to settle to the bottom. Some of the smaller particles of greater specific gravity will pass through the perforations in the bottom 11 onto the hopper bottom 9 of the air chamber of the separator cup. To prevent accumulations in the air chamber, these portions which fall onto the bottom 9 move down the same to the conduit 10 and thence to the discharge orifice 16. The coarser portions of the heavier material will pass to the center of the perforated bottom 11 and be discharged through the conduit 14 into the lower portion of the discharge conduit 10. These, with that which has fallen through the perforated bottom 11, are the richer portion of the ore which are to be extracted. The lighter portions of the material accumulate as an upper layer or stratum, and when it accumulates to a sufficient depth it is discharged over the upper edge of the separator chamber 8 and falls through the space 2' between the same and the walls of the casing 2, to the bottom 3, whence it passes out of the device through the chutes 5 and 6. To facilitate the discharge of the overflowing lighter material from the separator chamber, an annular deflecting plate 39 is mounted in spaced relation above the edge of the cup 8 and is held in position by supporting rods 40 preferably attached to the walls of the casing. With each air impulse material in separator is thrown upward and such as rises high enough to strike the deflector plate is moved outwardly or away from the center of vessel towards the overflow.

To prevent any of the lighter material from entering the discharge conduit 14, a spreader element is supported within the separator chamber directly above the discharge orifice 41 to the conduit, so that, as the pulverized ore is fed into the chamber it is deflected toward the sides thereof and away from said orifice. As there is during operation, an accumulation of the heavier material as a lower stratum on the perforated bottom, this deflector comprises a double cone shaped member 42 supported in any suitable manner as by supporting rods 43.

One of the primary objects of the invention is to provide a separator that will continue to operate at a uniform degree of percentage of perfection, irrespective of variations in the specific

gravity or richness of the pulverized ore fed thereto. To this end, I provide an improved feed mechanism and improved means for regulating the discharge of the heavier particles as they accumulate. An initial feed hopper 44 extends through the top of the housing 1 and has a discharge orifice 45 at its lower end. Said lower end of the initial feed hopper extends within the upper end of an inverted frusto-conical feed chamber 46 having steeply sloping sides 47 and terminating at its lower end in an orifice 48. Below the feed chamber and above the separator chamber is a compensating chamber 49. This is an inverted frusto-conical member fixedly supported as by rods 50 to the casing 2, so as to move with said casing and the separator chamber. The compensating chamber receives the material from the feed chamber 46, and its lower end is open forming a discharge orifice 51 through which it discharges the material into the separator chamber and upon the spreader or deflector 42. The feed chamber 46 is stationary, and its lower ends extend a considerable distance within the compensating chamber so as to remain within the same, irrespective of the movements of the compensating and separating chambers. The orifice 51 is smaller than the orifice 47, and this in turn is smaller than the feed hopper orifice 45, so that, when the material is being fed through the hopper 44 the material is maintained in the feed chamber 46 at substantially the level of the orifice 45; and the material in the compensating chamber is maintained at a level with the orifice 48.

Due to the steeply sloping side 47 of the feed chamber 46, the pulverized ore is delivered to the compensating chamber 49 at a uniform consistency, that is, at a uniform degree of compactness. Without any material in the separator, the separating mechanism is exactly balanced by the tare weight 23, so that when the material is delivered to the compensating chamber, the weight of said material therein tends to move said mechanism downwardly; and it is obvious that the degree of such movement is dependent upon the specific gravity of the material in said chamber. With this downward movement, the capacity of the compensating chamber is increased due to the relative greater distance between the orifices 48 and 51. This downward movement is therefore not directly proportional to the specific gravity of the material in the compensating chamber, but is proportional to the specific gravity and the variations in the volume of the material. It is in order to maintain the device in a fixed position of balance after it has reached a position due to the change of weight in the compensating chamber, that I provide the pendulum 25—26; and the pendulum weight can be adjusted on the pendulum arm to secure the desired balance between the same and the material in the chamber 49. It is obvious, that any variation in the specific gravity of the ore being delivered will cause a corresponding shifting in the position of the separator, for a purpose which will appear hereinafter. Should the delivered material be of a greater specific gravity than that expected, the weight of the material in the compensating chamber will increase and tend to move the device downwardly proportional to the increased weight. Likewise a decrease in the specific gravity will decrease the weight in the chamber and permit the separating device to rise according to the corresponding decrease

in the volume of heavier material in said chamber.

Means are provided, in combination with the compensating chamber and pendulum, for recording the specific gravity of the material being delivered. To this end, an indicator arm 52 is fixed to the fulcrum shaft 8 and carries a stylus 53 for cooperation with the drum 54 which is driven in any suitable manner, as by clock work (not shown). This drum carries suitable indicia indicating 100% of heavy material in the ore, and zero indicating no heavy material. It may be graduated in between these limits to indicate any degree of perfection. It is obvious, therefore, that the grade or quality of the ore being fed to the device and the variations in its quality may be determined by reference to this indicating mechanism.

As the material is constantly fed to the separator at a substantially uniform rate, it is obvious that the combined discharge of both the heavier and lighter materials must equal the input; but the percentage of lighter and heavier material discharged from the machine will vary proportionately to the percentage of these materials in the ore. Theoretically, the material in the separator chamber is stratified into a lighter upper stratum and a lower heavier stratum, but between these perfectly separated strata is an intermediate portion composed of both heavier and lighter materials. Means are provided whereby the ore may be split, at any specific gravity. This will depend upon the permitted rate of output or discharge of the accumulated heavier material. To this end, the discharge orifice 16 of the discharge conduit 10 is valve controlled so that there is no discharge of the heavy material when the device is at its upper limit of movement, and a complete and unchecked discharge therefrom when the device is in its lowermost position. In order to maintain a constant discharge when the heavier or richer portion is 100% of the input, and prevent over-accumulation, said discharge orifice 16 is of a capacity exceeding the capacity of the device, that is, exceeding the maximum inflow at the orifice 51. The valve for the orifice 16 comprises a plate 55 mounted in the upper end of the chute 17 and against which the lower end of the conduit 10 is firmly seated when the separator is at its upper limit of movement so as to completely close the orifice 16. As soon as any downward movement of the separator is initiated, the apertured end of the conduit is moved away from the valve plate to relieve friction, and further downward motion will move the same to uncover the aperture 16 according to the degree of movement. In order to unseat the end of the chute upon initial downward movement, a lever 56 is provided, parallel with the supporting beam, and having its fixed end pivoted directly under the fulcrum shaft 18 of the beam, and its free end pivotally connected as at 58 to the conduit 10 on an axis directly below the connection between the yoke 20 and the lugs 21. This arrangement not only relieves the friction between the conduit and the valve 55 but maintains the device in true vertical position. The supporting beam and the lever 56 are preferably horizontal when the device is at its upper limit of movement so that the initial downward movement will retract the end of the conduit from the valve plate 55.

As the movement of the separator casing is primarily for the purpose of regulating the discharge of the heavier material from the orifice

16, the downward movement is stopped at a position where said orifice is fully below the valve plate 55. The upper limit of movement is such as to bring the lower part of the orifice somewhat above the bottom of the valve plate so as to allow some accumulation, and consequent slight downward movement, before a position is reached to begin the discharge. To this end, stops 59 and 60 are provided on the casing 2 and a fixed stop 61 is arranged, as on the housing 1, to cooperate therewith; the distance between the stops being such as to permit the desired maximum movement of the separator chamber and discharge conduit.

By decreasing the discharge rate of the heavier material, the ore will be split at a higher specific gravity, whereas by increasing the rate of discharge of the heavier material, it will be split at a lower specific gravity. In order that the ore may be split as desired according to the desired perfection of the output, the counterpoise 24 is provided on the graduated bar 22. By moving the counterpoise toward the fulcrum shaft, the weight of material will lower the separator, permit more rapid discharge of the heavier portions and split the ore at a lower specific gravity. By moving the counterpoise away from the fulcrum shaft the rate of discharge will be lessened and the ore split at a higher specific gravity. It is obvious that when splitting at a higher specific gravity, more of the heavier material will accumulate in the separating chamber than when splitting at a lower specific gravity.

As the input feed is no greater than the capacity of the device, the combined output of light and heavy material must equal the input. Consequently, the volume of material in the separating chamber is controlled by the ratio of lighter to heavier material. The greater the accumulation of heavier material in the device, the less lighter material is required to maintain the mechanism in equilibrium; whereas with a decrease in the quantity of heavier material, there must be a corresponding increase in the quantity of lighter material; therefore, with a less degree of discharge of the heavy materials there is a correspondingly greater discharge of the light material.

The air valve 37 creates intermittent agitations of material in separator cup 8, causing the material to rise and fall with each air impulse. The rising material at the top of each rise, strikes the deflector plate 39 and is deflected outwardly from the center of cup causing the material to pile up and overflow the edge of the cup so that it falls in space 2, to bottom 3 whence it passes out of the device through chutes 5 and 6. It is obvious that the amount of material discharged over the top discharge of cup 8 will be in relation to the amount of material striking the deflector plate 39. When the cup is full, the discharge at its top will be maximum; with a thinner total bed, the discharge will decrease until the bed becomes so thin that no material is raised high enough to strike the deflector plate or overflow the top of cup 8.

When the operation is for very light material there is but a small bed of heavy material in the chamber and a large bed of light material; and the cup is full. This is the normal weight to be kept constant, and the output of light material is substantially equal to the inflow. With more dense material, there is a thinner total bed as there is an increase in the amount of heavier material, obviously requiring a less amount of the

light material to produce a balance. With substantially all heavy material, there is a thin total bed and a thicker bed of heavier material. The line of separation x between the heavy and light layers thus rises and falls to maintain the same weight with either increased or decreased volumes. This is illustrated in Figs. 3, 4 and 5 of the drawings. However, as there is a constant volume of feed, any variation in the specific gravity of the ore will vary the weight of the material in the separator cup which causes the separator to rise or fall accordingly, thereby varying the ratio of the heavier and lighter material until the device reaches the point of equilibrium for the material being operated upon.

Thus, when the device has been set through the medium of the pendulum weight 26 and counterpoise 24 to operate upon material of a known or expected specific gravity and to split the same at the desired degree of richness, such degree of richness, or perfection will be maintained irrespective of fluctuations in the specific gravity of the ore fed to the device. Should the level of the heavier materials tend to rise into the upper field of agitation, the accumulated excess weight would lower the separating chamber, open the valved orifice 16 and permit discharge of the material to thus return the device to normal position and its equilibrium, and a constant quality of the output. Should the amount of heavy material in the ore fed to the machine become less, the proportionate accumulation of the heavy material will be less and the separator will rise, lessening the output of the heavier portion, and causing a greater discharge of the lighter material. Likewise, upon an increase in the specific gravity of the ore, the weight of the accumulated heavy portion will increase and lower the separator, thereby increasing the output of the heavier particles and lessening the output of the light material.

The accumulated heavy portions in the discharge conduit 10 above the lower end of the conduit 14, acts as a valve to control the air pressure so that when the ore is running at substantial perfection, the device will move to its lowest position giving an unrestricted flow of the heavier material. The lower end of the conduit 14 will be free from the clogging action of the material in the conduit 10 and permit air to enter there-through, relieving the pressure in the air chamber and consequently lessening the agitation in the separator chamber.

When extra light material is operated upon, it may be desirable to provide an air controlling damper in the air duct 27 so as to avoid excessive agitation. 62 indicates such a damper, which is connected to a movable portion of the device to open and close automatically with the fall and rise of the separator. This may be conveniently connected to the tare weight as indicated at 63. With an excess accumulation of lighter material in the separator chamber, the separator will rise and as it rises, the damper is closed proportionately to the rise, so that the agitation of the material is decreased so as to avoid carrying over into the waste some of the valuable portions of the ore. As the heavier portions accumulate, either by continuing action upon the extremely light ore or by an increase in the quality of the ore, the separator will drop, opening the damper proportionately to the degree of movement, and thereby increase agitation.

In order that the device will start and stop automatically upon the feeding or cessation of the

feed of the ore, the initial feed hopper 44 is mounted upon a tilting bar 64, fulcrumed at 65 and having a counterweight 66, which is of greater weight than the hopper 44 when empty, but of less weight than the combined weight of the hopper and contained ore. The end of the bar 64 opposite the hopper is provided with a contact member 67 which is adapted, when ore is in the hopper 44, to engage the contact 68, closing the circuit 69 to the motor. As long as material is being fed to the hopper 44, the circuit to the motor is closed through the contacts 44 and 45. As soon as the materials cease to flow through the hopper 44, the counterweight 66 raises the hopper and breaks the circuit to the motor, thereby stopping the operation of the device.

I claim:

1. A device for separating the heavier from the lighter portions of pulverized material, comprising a separator chamber having a pervious bottom 20 and means for forcing air currents through the bottom of said chamber, in combination with means for feeding pulverized material to said chamber at a fixed volume rate, means for discharging the heavier portions of the material from said chamber, means acting on said discharging means to maintain a substantially constant weight of material in said chamber, and means governed by the specific gravity of the material being fed and controlling said discharging means to cause the discharge of the heavier portions of the material from the separator chamber according to variations in the specific gravity of the material as it is fed to the separator chamber.

2. In a separator of the class described, a separator chamber having a pervious bottom, means for forcing air currents through the bottom of said chamber, and means for feeding the material to said chamber at a uniform volume rate, in combination with means for discharging the heavier portions of the material from said chamber, means acting on said discharging means to maintain a substantially constant weight of material in said chamber, and means responsive to density changes in the material while being fed by the feeding means for ascertaining the density of the material as it is fed to the separator chamber and acting on said discharging means to vary the rate of discharge of the heavier material from the separator chamber according to variations in the density of the material.

3. In a device of the class described, a separator chamber having a discharge for the heavier portions of the material, balance means movably supporting said chamber and controlling said discharge, and agitating means, in combination with means for feeding material to said chamber at a constant volume rate, compensating means for determining the relative density of the material as it is fed to the separator chamber and acting on said balance means to control said discharge according to variations in density of the material, said compensating means including means for delivering the material to the separator chamber at a uniform degree of compactness.

4. In a device of the class described, a separator chamber having a discharge for the heavier portions of the material, balance means movably supporting said chamber and controlling said discharge, and agitating means, in combination with means for feeding the material to the chamber at a constant volume rate, and compensating means supported by said balance means for determining the relative density of the material as it is fed to the separator chamber and acting to control said

discharge according to variations in density of the material, said compensating means including a feed housing having steeply inclined walls and a bottom discharge orifice for delivering the material at a uniform degree of compactness.

5 5. In a device of the class described, a separator chamber having a discharge for the heavier portions of the material, balance means movably supporting said chamber and controlling said discharge, and agitating means, in combination with
10 means for feeding material to the chamber at a constant volume rate, compensating means for determining the relative density of the material as it is fed to the separator chamber and acting
15 on said balance means to control said discharge according to variations in density of the material, and means responsive to said compensating means for recording variations in density of the material as it is fed to the separator chamber.

20 6. In a separator of the class described, a separating chamber having balance means supporting it for limited vertical movement due to the accumulated weight of material therein, a downwardly extending discharge conduit for the
25 heavier material, a compensating chamber supported by said balance means above the separating chamber and movable vertically therewith, said chamber having steeply sloping sides and an aperture in its lower end, a feed chamber having
30 steeply sloping sides and an apertured end extending into the compensating chamber and means for counterbalancing the weight of material in the compensating chamber in the various vertical positions of the separating chamber.

35 7. A device of the class described comprising a separator cup mounted for limited vertical movement due to the variations of weight in its contents, a discharge conduit at the bottom of
40 said cup, a perforated plate in said cup dividing the same into an upper separating chamber and a lower air chamber, a discharge conduit extending downwardly from the separating chamber into the upper portion of the first said
45 discharge conduit and forming a passageway between said conduits which communicates with said lower air chamber, means for supplying air under pressure to the air chamber, means for feeding granular material to the separating chamber at a fixed volume rate, and a valve
50 controlling the lower end of said first discharge conduit to regulate the discharge of material therefrom proportionate to the vertical position of said chamber and through which air from said air chamber may escape more or less freely according
55 to the amount of material contained in the first said discharge conduit.

8. In a device of the class described, a separator casing, including a hopper bottom having
60 a discharge opening, a separator cup arranged within said casing and spaced from the walls thereof, a perforated plate separating said cup into an upper separating chamber and a lower air chamber, means for supplying a pulsating current of air to said air chamber, a downwardly
65 extending discharge conduit from said air chamber, a discharge conduit extending downwardly from the separating chamber into the first said conduit, the lower end of the first said conduit having a lateral discharge orifice, a stationary
70 valve plate constituting a control for said orifice, a balance beam supporting said casing and separating mechanism, a tare weight for balancing the same, and a counterpoise on said beam for determining the normal vertical position of the
75 separator chamber for separating the ore at a de-

sired degree of richness, substantially as described.

9. A device as set forth in claim 8 further characterized by a compensating chamber arranged above said separating chamber and movable
8 therewith, said chamber comprising an inverted frusto-conical member open at the bottom, a stationary feed chamber having steeply inclined sides and an open lower end extending into said compensating chamber, and a pendulum in fixed
10 relation to said beam, substantially as described.

10. A device as set forth in claim 8 further characterized by a compensating chamber arranged above said separating chamber and movable
15 therewith, said chamber comprising an inverted frusto-conical member open at the bottom, a stationary feed chamber having steeply inclined sides and an open lower end extending into said compensating chamber, and a pendulum in fixed relation to said beam, said pendulum
20 comprising a pendulum arm and a pendulum weight adjustable thereon, as and for the purpose specified.

11. In a device of the class described comprising a separator casing having a hopper bottom,
25 a separator cup arranged within the casing and spaced from the walls thereof, said cup having a hopper bottom and a vertically disposed discharge conduit, a perforated plate dividing said cup into an upper separating chamber and a lower air
30 chamber, said plate constituting a hopper shaped bottom for said chamber, a discharge conduit from the same extending into the upper end of the first said discharge conduit, means for supplying a pulsating air current to said air chamber, means for feeding ore centrally to said chamber and a spreader member fixedly supported
35 in said chamber above the entrance to its respective discharge conduit, substantially as described.

40 12. A device of the class described comprising an outer separator casing, a separator cup arranged within the same and spaced from the walls of said casing, said cup having a hopper shaped bottom and a discharge conduit extending
45 downwardly therefrom, a hopper shaped perforated plate dividing said cup into an upper separating chamber and a lower air chamber, a conduit extending downwardly from said separating chamber into the upper end of said first said conduit,
50 the first said conduit having a lateral discharge opening in its lower end, a fixed plate normally closing said opening and constituting a valve for the same, a balance beam supporting said separating mechanism, a tare weight on said beam
55 balancing the same, and a lever parallel with said beam having one end pivoted beneath the fulcrum of the beam, and the other end pivotally connected to the discharge conduit directly below the connection of the beam to the separator mechanism, as and for the purpose specified.

13. A device as set forth in claim 12 further characterized by a means for supplying a pulsating
60 air current to the air chamber and comprising an air duct extending laterally from the air chamber, a fan and fan housing communicating with said air duct and an interrupter valve rotatably mounted in said duct, substantially as described.

14. A device as set forth in claim 12 further characterized by means for supplying air under
70 pressure to said air chamber and comprising an air duct extending laterally from the air chamber, a fan and fan housing communicating with said duct and a flexible section in said duct
75

adjacent said casing to permit rise and fall of the separating mechanism, substantially as described.

15. A device of the class described comprising an outer separator casing having a limited vertical movement, a separator cup arranged within the same and movable therewith and spaced from the side walls thereof to form passages extending downwardly from the top of the separator cup to the exterior of the casing for the descent and discharge of separated portions of lighter material, a perforated plate dividing said cup into an upper separating chamber and a lower air chamber, discharge conduits extending downwardly from said chambers, and means for controlling the discharge of the heavier portions of the material under the control of the vertical movements of the separator casing, a stationary dust hood above said separator casing, the upper end of said casing being open and extending loosely into said hood, spaces being provided between said casing and hood for the admission of air to the latter, and means for supplying an air current to said air chamber comprising a fan and fan housing, an inlet duct for said fan housing communicating with said dust hood, and a duct leading from said fan casing to said air chamber, substantially as described.

16. A device as set forth in claim 15 in combination with a motor for said fan and a pivotally mounted initial feed hopper, an electric circuit for said motor and a circuit closer in said circuit actuated by tilting of the said initial feed hopper.

17. A device of the class described, comprising a separator housing having a hopper bot-

tom, and a discharge chute; a separator cup arranged within said casing and having a hopper bottom, a discharge conduit extending downwardly from said bottom, the lower end of said discharge chute having a lateral discharge orifice, a fixed valve for normally closing said orifice, a hopper shaped perforated plate dividing said cup into an upper separating chamber and a lower air chamber, a discharge conduit extending downwardly from said perforated plate into the upper end of the first said conduit, a balance beam supporting said separating mechanism, means for supplying pulsating currents of air to said air chamber, in combination with feeding means for said separating chamber comprising a compensating chamber fixedly supported above the same and comprising a frusto-conical member having an open lower end constituting a discharge orifice, a stationary feed housing having steeply sloping sides and terminating in an apertured end arranged within said compensating chamber, and an initial feed hopper having an apertured end extending into said feed housing, the discharge orifice of the compensating chamber being smaller than the discharge orifice of the feed chamber and the discharge orifice of the feed chamber being smaller than the discharge orifice of the initial feed hopper, substantially as described.

18. A device as set forth in claim 17 further characterized by a weighted pendulum fixedly connected to said balance beam, as and for the purpose specified.

JOSEPH W. REED. 35