

A. WURM.

ADJUSTABLE HOLDER FOR BRUSHES OR BROOMS.

(Application filed July 3, 1902.)

(No Model.)

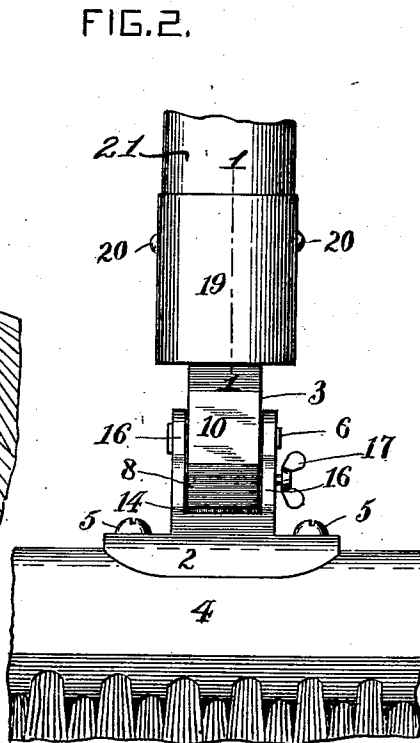
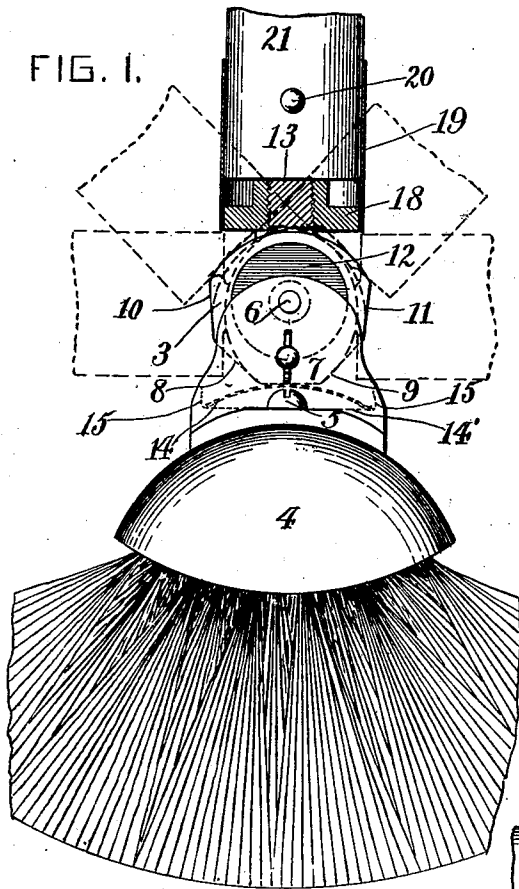

WITNESSES

*R. Champion*

*Nicholas Dimmett*

INVENTOR

*Alexis Wurm*

BY

*R. Champion*

ATTORNEY

# UNITED STATES PATENT OFFICE.

ALEXIUS WURM, OF WEST HOBOKEN, NEW JERSEY.

## ADJUSTABLE HOLDER FOR BRUSHES OR BROOMS.

SPECIFICATION forming part of Letters Patent No. 714,089, dated November 18, 1902.

Application filed July 3, 1902. Serial No. 114,258. (No model.)

*To all whom it may concern:*

Be it known that I, ALEXIUS WURM, a citizen of the United States, and a resident of West Hoboken, in the county of Hudson and State of New Jersey, have invented certain new and useful Improvements in Adjustable Holders for Brushes or Brooms, of which the following is a specification.

This invention relates to adjustable holders for brushes and brooms, the main object being to provide a holder by means of which a brush-head or broom-head may be quickly adjusted and securely held in any one of several positions for the purpose of brushing or cleaning the corners of a room thoroughly at the intersection of the side walls with the ceiling and also at other points.

In carrying my invention into effect I make use of a holder having two main parts, one of which is adjustable on and is preferably oscillatory relatively to the other, and means for retaining these two parts in any desired adjusted position to hold the brush-head or broom-head which is secured to one of the members at the desired angle with respect to a handle to which the other member of the device is fastened. One of these two main members will preferably have a plurality of holding-faces, which may be flat faces intersecting one another, and any one of these faces may be engaged and held by a strong spring, such as an arched plate-spring, which will engage a considerable portion of such flat surface. These flat faces may be formed on the periphery of a pivoted block fastened to the handle of the brush or broom and in such case will usually be perpendicular to radii passing through the center of oscillation of such member. In order to assure the permanent location in the desired angular position with respect to the handle, an auxiliary device, such as a clamp-screw, may be employed to lock the two members of the holder together positively.

In the drawings accompanying this specification and forming part of the present application, Figure 1 is an end elevation, partly in section, on the line 11, Fig. 2, of an adjustable holder constructed in accordance with my invention and shows the normal positions of the parts in full lines, the other positions being indicated by dotted lines. Fig.

2 is a side elevation of the same with parts of the brush removed.

As before stated, my improved adjustable holder has two main parts movable relatively to each other to change the relative positions of the brush or broom and its handle. One of these parts is a base-piece in the form of a fixed block or housing, such as 2, and is preferably secured to the back of an ordinary brush 4 by means of screws 5. The other member in the construction shown is a pivoted block, such as 3, which may be mounted on a pin 6 for oscillation between the side walls 16 of the fixed block or base 2. The pivot of the swinging block 3 may be a pin or rivet, a machine-screw having a smooth shank, or any similar element.

The swinging block 3 has a plurality of holding-faces, any one of which may be brought into line with the handle of the brush and snapped into locking engagement with a suitable spring. These holding-faces are preferably flat portions of the periphery of the block 3 and may be so placed as to permit the brush-head to be turned in one direction only from a central position or in both directions from such central position. In this case the swinging block has five peripheral holding-faces, designated, respectively, by 7, 8, 9, 10, and 11. The first of these is the central flat face, the next two being holding-faces intersecting the face 7 at opposite sides thereof, while the faces 10 and 11 control the extreme adjustments of the brush-head and intersect the faces 8 and 9, respectively. All of these faces are preferably perpendicular to radii, passing through the axis of oscillation of the swinging block 3.

All of the holding-faces just described are located substantially at one side of the axis of the swinging member 3. At the other side thereof said member preferably has a screw-threaded shank 13, which may be screwed into a correspondingly-threaded bore in a socket adapted to receive the end of the brush-handle. The sides of the swinging block 3 are preferably hollowed out or cupped, as shown at 12, to reduce the weight of the block.

Between the side walls 16 and 17 thereof the base 2 of the holder is so shaped as to provide a supporting-face 14, on which may rest the spring for engaging the peripheral hold-

ing-faces of the swinging block. This spring should be a strong arched plate-spring, substantially as shown at 14, which will always be in contact with one of the faces of the swinging block and will preferably engage a considerable portion of the length of such face. It will be evident that as the spring engages each face at the center thereof, which is the point nearest the axis of oscillation of the block, the spring tends to center itself on each face with which it coöperates, and considerable force must be exerted to cause the brush-head to turn and the spring to ride up the cam-slope of any of said faces. Any one of the five faces of the swinging block may be brought into engagement with the central portion of the arched spring 14, as shown in Fig. 1, and the brush-head correspondingly located and locked in any one of four positions, two at each side of the normal central position shown in full lines, the position to which the brush-head is shifted being of course dependent upon the position of the wall or other surface to be brushed relative to the handle 21.

In order to keep the spring 14 from falling out, the block 2 may have end walls, such as 15, rising from the spring-supporting face 14'; but these end walls should not be close enough together to prevent the proper operation of the spring.

In connection with the spring 14 and the flat faces coöperative therewith for locating and holding the swinging block I may make use of an auxiliary locking device, such as the winged clamp-screw 17, which passes through an opening in one of the walls 16 of the fixed block 2 and impinges against the adjacent side of the swinging block 3. When the parts are in the desired adjusted position, this screw may be turned slightly to clamp the main members positively together, and a slight turn in the opposite direction is sufficient to release the clamp-screw. In this construction the socket for the end of the handle 21 is a sleeve or ferrule 19, pinned to said handle, as shown at 20, and closed at the end adjacent the swinging block 3 by a plug 18, brazed or otherwise secured to said sleeve and having a screw-threaded bore for the reception of the threaded shank 13 of the swinging block.

A holder constructed in accordance with my invention constitutes a very simple and practical device for adjusting a brush-head to and locating and locking it in any one of a plurality of positions and facilitates greatly the work of cleaning walls, ceilings, and corners, especially when these are formed at varying angles with respect to one another, and the thorough cleaning of such walls, &c., is assured when an adjustable brush-head of this type is used.

What I claim is—

1. An adjustable holder for brushes and brooms, comprising a pair of relatively movable members secured respectively to the handle and to the head of the article one of which members has a spring and the other of which has a plurality of holding-faces coöperative respectively with said spring for locating said members in different relative positions and locking them together.

2. An adjustable holder for brushes and brooms, comprising a pair of relatively movable members secured respectively to the handle and to the head of the article one of which members has a spring and the other of which is oscillatory on the first and has a plurality of flat holding-faces substantially perpendicular to radii drawn through the center of oscillation and coöperative respectively with said spring for locating said members in different relative positions and locking them together.

3. An adjustable holder for brushes and brooms, comprising a base and a block one secured to the handle and the other to the head of the article, said block being pivoted on said base and having a central holding-face and holding-faces at one side of said central face, and an arched plate-spring supported on said base and coöperative with said holding-faces respectively for locating said block in different relative positions and locking it to said base.

Signed at New York, in the county of New York and State of New York, this 2d day of July, A. D. 1902.

ALEXIUS WURM.

Witnesses:

EDGAR A. FELLOWS,  
C. S. CHAMPION.