

No. 689,784.

Patented Dec. 24, 1901.

W. F. BRADBURY & D. E. WASHINGTON.
STOP MECHANISM FOR ENGINES.

(Application filed Apr. 5, 1900.)

(No Model.)

2 Sheets—Sheet I.

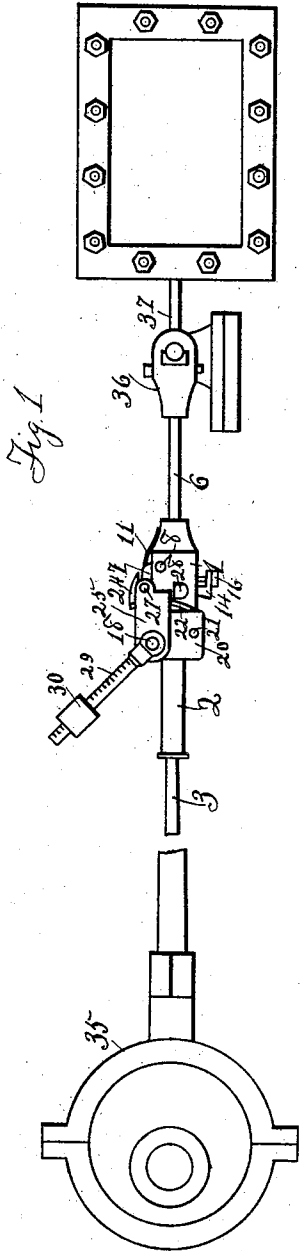

Fig. 1

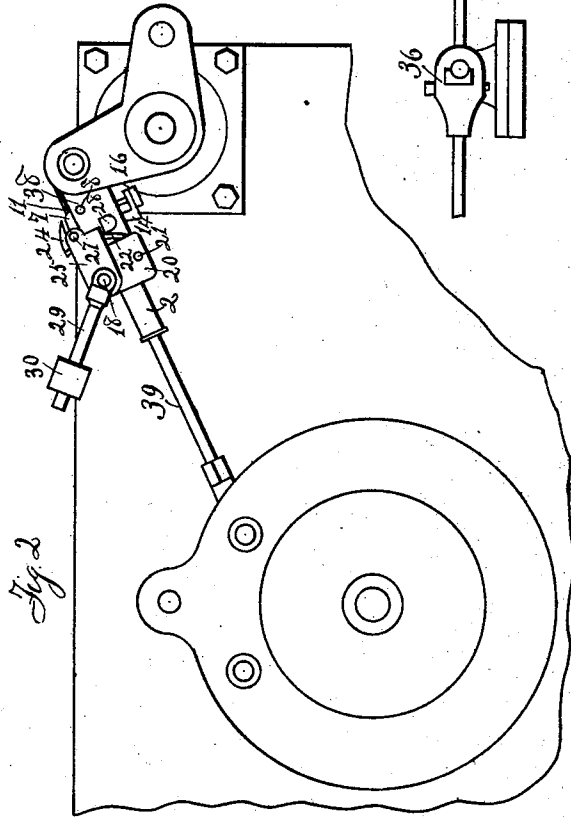

Fig. 2

Fig. 1

Witnesses
A. Brown
D. L. Osborne

Inventors
W. F. Bradbury
D. E. Washington
by *J. L. Brown*
Attorney

No. 689,784.

Patented Dec. 24, 1901.

W. F. BRADBURY & D. E. WASHINGTON.
STOP MECHANISM FOR ENGINES.

(Application filed Apr. 5, 1900.)

(No Model.)

2 Sheets—Sheet 2.

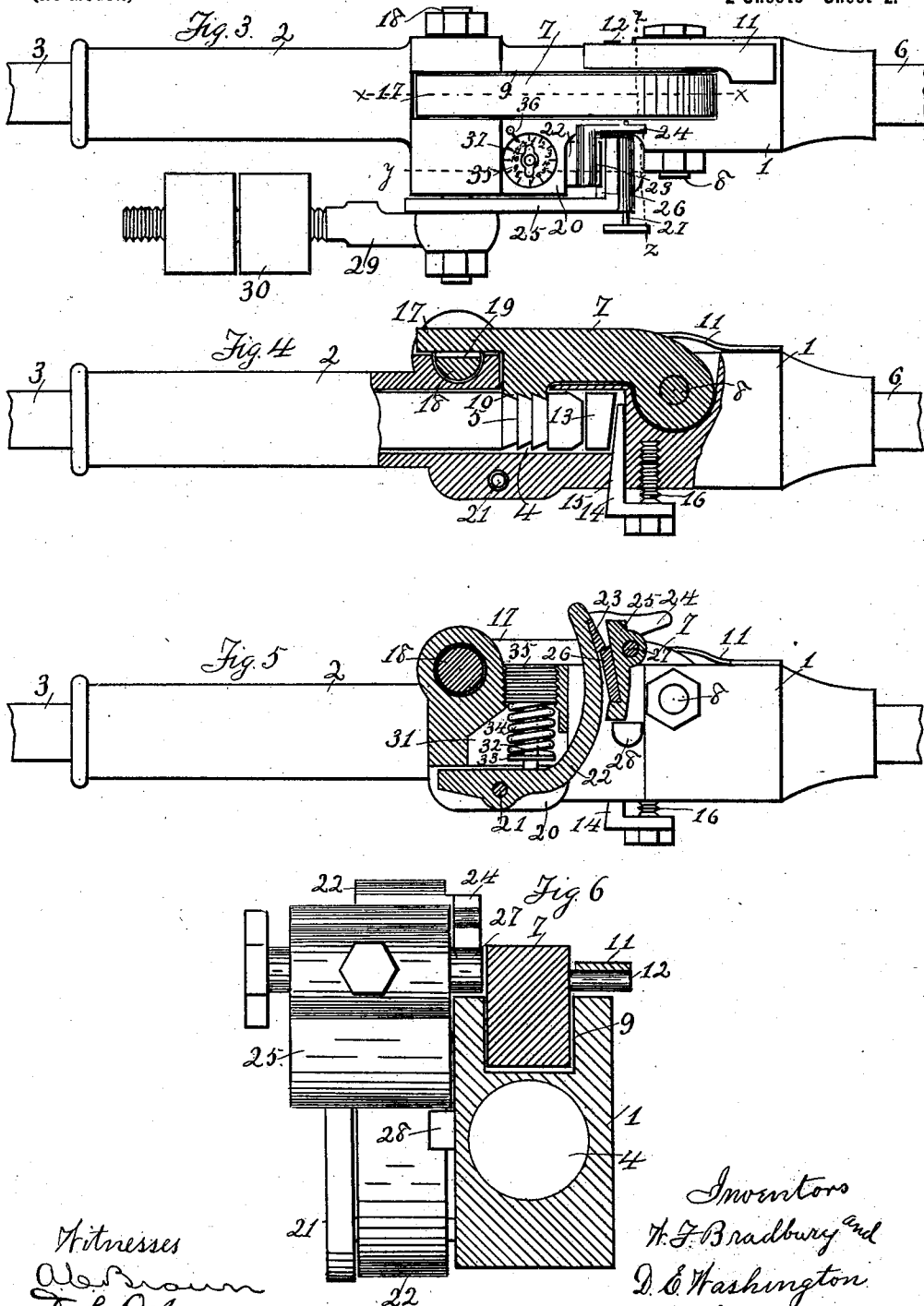

Witnesses
A. Brown
D. L. Osborne

Inventors
W. F. Bradbury and
D. E. Washington
by J. S. Brown
Attorney

UNITED STATES PATENT OFFICE.

WILLIAM F. BRADBURY, OF KANSAS CITY, KANSAS, AND DIXON E. WASHINGTON, OF KANSAS CITY, MISSOURI.

STOP MECHANISM FOR ENGINES.

SPECIFICATION forming part of Letters Patent No. 689,784, dated December 24, 1901.

Application filed April 5, 1900. Serial No. 11,660. (No model.)

To all whom it may concern:

Be it known that we, WILLIAM F. BRADBURY, of Kansas City, in the county of Wyandotte, in the State of Kansas, and DIXON E. WASHINGTON, of Kansas City, in the county of Jackson, in the State of Missouri, citizens of the United States, have invented certain new and useful Improvements in Stop Mechanism for Engines, of which the following is a full, clear, and exact description, reference being had to the accompanying drawings, which form a part of this specification.

Our invention relates to improvements in stop mechanism for engines, having more particular reference to improvements in the mechanism for which Letters Patent of the United States were granted to us, whereby the same is adapted to the reciprocating motion of a slide-valve engine and also to be applied upon the steam-rod in certain engines of the Corliss type in which it is not convenient or not possible to place the device upon the sleeve of the bell-crank or other part of the valve-gearing; and our invention consists in certain features of novelty hereinafter described, and pointed out in the claims.

Figure 1 represents a side elevation of a slide-valve engine, showing our improved stop mechanism applied upon the eccentric-rod. Fig. 2 represents a side elevation of a Corliss valve-gear, showing our improved stop mechanism applied upon the steam-rod. Fig. 3 represents a top plan view of our improved stop mechanism. Fig. 4 represents a longitudinal cross-section on the line X X of Fig. 3. Fig. 5 represents a longitudinal cross-section on the line y y of Fig. 3. Fig. 6 represents a cross-section on the line Z Z of Fig. 3. Fig. 7 represents a side elevation of a slide-valve engine, showing our improved stop mechanism applied upon the valve-rod.

Similar numerals refer to similar parts throughout the several views.

1 represents an extension-chamber, which as it carries the working parts of the device may for brevity be called a "saddle." Said saddle is provided with a telescoping sleeve 2, within which telescopes a rod 3, which entering a socket 4 in the saddle is provided within the socket with a series of ratchet-teeth 5.

As shown in Fig. 1, the device may be applied upon a slide-valve engine by dividing the eccentric-rod and mounting the saddle between the eccentric 35 and the cross-head 36, the rod 3 being connected with the eccentric and the saddle connected with the other section 6 of the eccentric-rod, and thus indirectly through the cross-head with the valve-stem 37, or, as shown in Fig. 7, the saddle may be connected directly to the valve-stem and the rod 3 to the cross-head, and the device thus mounted between the cross-head and the valve, or, as shown in Fig. 2, said saddle may be made the saddle of a pitman-head 38 on a Corliss engine, as shown in said figure, the connection made to the steam-arm 39 of the bell-crank, the rod 3 being connected to the wrist-plate 40 and becoming the steam-rod, or, as is obvious, if said saddle be made the saddle of the pitman-head on a slide-valve engine the connection may be made to the cross-head and the rod 3 will become the eccentric-rod; but wherever mounted or whatever the arrangement, the device being operated by the reciprocating motion given to the saddle, the action will be substantially the same.

7 represents a pawl pivotally mounted upon a pin 8 in a recess 9, formed in the saddle, the teeth 10 of said pawl engaging the ratchet-teeth 5 of said rod 3, and to retain the pawl in engagement with the ratchet-teeth a spring 11 is secured upon the saddle and engages a lug or pin 12 on the pawl. A wearing-block 13 in the socket 4 forms an abutment against which the head of the rod 3 bears when the teeth of the pawl are in engagement, a key 14, seated in a key-seat 15, backing up the block 13 to take up any slack in the engagement of the teeth and also to take up any wear that may occur, said key being adjustable by means of a set-bolt 16, threaded into the saddle. On said pawl is provided a tripping-finger 17, extending a suitable distance in advance of the pawl, the purpose of which will appear. On said saddle at or near its junction with the sleeve 2 is journaled a rocking shaft 18, in which is provided a recess 19 of substantially half the diameter of the shaft and arranged to form a trip under said tripping-finger 17 of the pawl. On the side of

saddle is formed a recessed latch-block 20, in which is pivotally mounted at 21 a curved latch-lever 22, provided near its extremity with a latch 23 and a latch-finger 24. On said rocking lever is fixedly mounted a catch-plate 25, having thereon a catch 26, arranged to engage the latch 23, and a pin 27 is loosely mounted in said catch-plate and arranged to slide through the same in the plane of and be engaged by said latch-finger 24. A stud or stop 28 on the saddle is provided to limit the movement of said plate. Also fixedly mounted on said rocking shaft is a weight-arm 29, carrying the weights 30, preferably threaded thereon for adjustment, and two weights are preferably used, so that when adjusted they may be locked against accidental displacement, and a scale marked on the arm is of great convenience in fixing the position of the weights.

In the recess 31 in the latch-block 20 is mounted a stem 32, bearing at one end upon the latch-lever and provided with a disk or collar 33, upon which is seated a tension-spring 34. A screw-plug 35 is threaded into the block, and bearing upon the spring serves to regulate the tension thereof, the latch 23 being held in engagement with the catch 26 by the tension of the spring, and an index on the exposed face of the plug, with an index finger or pointer 36 on the block adjacent thereto, is very convenient in noting the desired tension of the spring or any displacement of the plug. A keyhole 37 for a suitable key is provided for operating the plug.

The tension of the spring 34 upon the latch-lever being set and the weight 30 adjusted to a predetermined speed limit, if the speed of the engine exceeds such limit under the reciprocating movement given to the saddle the inertia and momentum of the weight will overcome the tension of the spring, and the catch will be released from the latch. As the catch-plate is thus released the weight will fall, and the weight-arm being fixed upon the shaft 18 said shaft will be turned. Said shaft in turning will act upon the tripping-finger 17 to raise the pawl and release it from engagement with the ratchet-teeth on the rod 4, and said rod, being released, will slide loosely in the telescoping sleeve, and the valve will not be operated to admit steam to the cylinder to act upon the piston, and the engine will be shut down. If, however, the pin 27 be moved and set in the path of the latch-finger 24, the relation is such that while the rod is released and the steam shut off from entering the cylinder the pin will be caught by the latch-finger and the trip still held by the latch-lever, and as the movement of the parts stops the tension of the spring acting upon the latch-lever will counteract the weight and draw the trip back to its normal position and permit the pawl to again engage the rod, and the engine will resume its work. This arrangement of the latch-finger and pin is of great advan-

tage when, as in electric plants, a part of the load is liable to be thrown off without any warning, causing the speed of the engine to run up to a very undesirable degree, as in such case the speed is checked without throwing the engine out entirely, but leaving it ready to resume its work as the speed is cut down. It is also of very great advantage in case of accident to the governor, in which case the cut-off will control the valves without cutting out the engine, and thus in great measure perform the duty of the governor. It will be observed, however, that the construction, arrangement, and relation of the said latch-finger and pin are such that if the speed increase to a greater degree than usually occurs from a removal of part of the load the added momentum given the weight will release the pin from the latch-finger and shut down the engine, and thus prevent the occurrence of a "runaway."

The adjustment of the weight and the tension of the spring 34 may be made to such degree of accuracy that a very few revolutions above normal or predetermined speed limit will release the catch-plate and trip the pawl, thus making the device a very efficient and secure protection against accident arising from any excess of speed whether happening from the sudden removal of the load or from any other cause.

Having thus fully described our improvements, what we claim as our invention, and desire to secure by Letters Patent, is—

1. A stop mechanism for engines consisting of the combination with a saddle provided with a telescoping sleeve and having a longitudinal socket, a rod telescoping with said sleeve and entering said socket and provided with ratchet-teeth near its end, and a spring-controlled pawl, provided with a tripping-finger, mounted in a recess in said saddle and arranged to engage the ratchet-teeth on said rod, of a weighted trip mounted on said saddle and arranged to trip said pawl; a catch connected with said trip, and a spring-controlled latch mounted on said saddle and arranged to engage said catch to control said trip; substantially as set forth.

2. A stop mechanism for engines consisting of the combination with a rod having ratchet-teeth near its end, a saddle connected with the valve mechanism and provided with a sleeve telescoping with said rod and a pawl mounted on said saddle and engaging said rod, of a weighted trip mounted on said saddle and arranged to be operated by the reciprocations of said saddle at a certain predetermined speed limit to trip said pawl and release said rod, a catch connected with said trip, and a latch mounted on said saddle and arranged to engage said catch to control said trip until such speed limit is reached; substantially as set forth.

3. A stop mechanism for engines consisting of the combination with a rod, a saddle con-

5 nected with the valve mechanism and provided with a sleeve telescoping with said rod, and a spring-controlled pawl mounted on said saddle and engaging said rod, of a weighted trip mounted on said saddle and arranged to trip said pawl to release said rod, a catch connected with said trip, and a spring-controlled latch mounted on said saddle and arranged to engage said catch to control said trip; substantially as set forth.

15 4. A stop mechanism for engines consisting of a saddle reciprocating with the valve mechanism and provided with a sleeve, a rod telescoping in said sleeve, a pawl mounted on said saddle engaging said rod, and means controlled by the reciprocation of said saddle for tripping said pawl to release said rod; substantially as set forth.

20 5. A stop mechanism for engines consisting of the combination with a saddle connected with the valve mechanism and provided with a sleeve, a rod provided with ratchet-teeth, connected with the valve-operating mechanism, and telescoping with said sleeve, and a pawl mounted on said saddle engaging said ratchet-teeth on said rod, of a weighted trip mounted on said saddle and arranged to trip said pawl, a catch connected with said trip, a latch mounted on said saddle and arranged to engage said catch, a spring mounted on said saddle controlling said latch, and means for regulating the tension of said spring; substantially as set forth.

35 6. A stop mechanism for engines consisting of the combination with a saddle connected with the valve mechanism and provided with a telescoping sleeve, a rod provided with ratchet-teeth, connected with the valve-operating mechanism, and telescoping with said sleeve, and a spring-controlled pawl provided with a tripping-finger mounted on said saddle and engaging the ratchet-teeth on said rod; of a trip mounted on said saddle and arranged to engage said tripping-finger on said pawl, a weight connected with said trip, a catch connected with said weight, and a spring-controlled latch mounted on said saddle and arranged to engage said catch; substantially as set forth.

50 7. A stop mechanism for engines consisting of the combination with a saddle connected with the valve mechanism and provided with a telescoping sleeve, a rod connected with the valve-operating mechanism, and provided with a series of ratchet-teeth, telescoping with said sleeve, and a spring-controlled pawl engaging said ratchet-teeth and provided with a tripping-finger, of a trip mounted on said saddle and arranged to trip said pawl, a weight adjustably connected with said trip, a catch-plate provided with a suitable catch connected with said weight, and a spring-controlled latch mounted on said saddle and arranged to engage said catch; substantially as set forth.

65 8. A stop mechanism for engines consisting of the combination with a saddle connected

with the valve mechanism and provided with a telescoping sleeve, a rod connected with the valve-operating mechanism and provided with a series of ratchet-teeth, telescoping with said sleeve, and a spring-controlled pawl mounted on said saddle and engaging said ratchet-teeth and provided with a tripping-finger, of a trip mounted on said saddle and arranged to engage said tripping-finger to trip said pawl, a weight adjustably connected with said trip, a catch connected with said weight, a recessed latch-block formed on said saddle, a latch-lever mounted in said block provided with a latch arranged to engage said catch, a tension-spring mounted in said recess in said latch-block bearing on said lever to retain said latch in engagement with said catch, and a screw-stud mounted in said block and arranged to regulate the tension of said spring; substantially as set forth.

70 9. A stop mechanism for engines consisting of the combination with a saddle connected with the valve mechanism and provided with a telescoping sleeve, a rod connected with the valve-operating mechanism, and provided with ratchet-teeth, telescoping with said sleeve, and a spring-controlled pawl mounted on said saddle, and engaging said ratchet-teeth, of a trip mounted on said saddle and engaged to trip said pawl, a weight adjustably connected with said trip, a catch connected with said weight, a recessed latch-block formed on said saddle, a latch-lever mounted in said block, and provided with a latch arranged to engage said catch, a stem having a suitable collar mounted in the recess in said block and engaging said latch-lever, a tension-spring mounted on said stem, and a screw-plug mounted in said block and arranged to regulate the tension of said spring; substantially as set forth.

100 10. A stop mechanism for engines consisting of the combination with a saddle connected with the valve mechanism and provided with a telescoping sleeve, a rod connected with the valve-operating mechanism and provided with ratchet-teeth, telescoping with said sleeve, and a spring-controlled pawl mounted on said saddle and engaging said ratchet-teeth, of a weighted trip mounted on said saddle and arranged to be operated by the reciprocating movement imparted by the valve-operating mechanism to trip said pawl at a certain predetermined speed limit, a catch connected with said trip, and a spring-controlled latch mounted on said saddle and arranged to engage said catch to control said trip until such speed limit is reached; substantially as set forth.

115 11. A stop mechanism for engines consisting of the combination with a saddle connected with the valve mechanism, and provided with a telescoping sleeve, a rod connected with the valve-operating mechanism and provided with a series of ratchet-teeth, telescoping with said sleeve, and a spring-con-

70

75

80

85

90

95

100

105

110

115

120

125

130

5 trolled pawl engaging said ratchet-teeth, and provided with a tripping-finger, of a latch-block formed on said saddle, a weighted trip mounted on said block and arranged to be
 10 operated by the reciprocating movement of the valve mechanism at a certain predetermined speed limit to trip said pawl and release said rod, a catch-plate connected with said trip and provided with a suitable catch,
 15 a spring-controlled latch-lever mounted in said latch-block and provided with a latch arranged to engage said catch to control said trip until such speed limit is reached, a pin mounted in said catch-plate, and a latch-finger on said latch-lever arranged to engage said pin; substantially as set forth.

20 12. A stop mechanism for engines consisting of the combination with a saddle connected with the valve mechanism and provided with a telescoping sleeve, a rod connected with the valve-operating mechanism and provided with a series of ratchet-teeth, telescoping with said sleeve, and a spring-controlled pawl engaging said ratchet-teeth,
 25 of a latch-block formed on said saddle, a weighted trip mounted on said block and arranged to be operated by the reciprocating movement of the valve mechanism at a certain predetermined speed limit to release the
 30 valve mechanism from the valve-operating mechanism, a catch-plate connected with said trip, and provided with a suitable catch; a latch-lever mounted in said latch-block and provided with a latch arranged to engage said
 35 catch, a tension-spring mounted in said block and bearing on said latch-lever to control said trip until such speed limit is reached, a pin mounted on said catch-plate and a latch-finger on said latch-lever arranged to engage

said pin and to be operated by said spring to restore said trip to normal position; substantially as set forth.

40 13. In a stop mechanism for engines the combination with a latch-block connected with the valve mechanism, and a weighted
 45 trip mounted on said block and controlling the valve mechanism, of a catch-plate connected with said trip, a spring-controlled latch-lever mounted on said block and provided with a suitable latch arranged to engage said
 50 catch to control said trip, a pin mounted in said catch-plate and a latch-finger on said latch-lever arranged to engage said pin to restore said trip to normal position; substantially as set forth.

55 14. In a stop mechanism for engines the combination with a recessed latch-block connected with the valve mechanism and a weighted trip mounted on said block and controlling the valve mechanism, of a catch-plate
 60 connected with said trip, a latch-lever mounted in said latch-block, and provided with a latch arranged to engage said catch, a tension-spring mounted in said block and bearing on
 65 said latch-lever to control said trip, a pin mounted on said catch-plate and a latch-finger on said latch-lever arranged to engage said pin, and to be operated by said spring to restore said trip to normal position; substantially as set forth.

WILLIAM F. BRADBURY.
 DIXON E. WASHINGTON.

Witnesses as to William F. Bradbury:

THEO. L. CARNS,

TH. J. THORNHILL.

Witnesses as to Dixon E. Washington:

THEO. L. CARNS,

P. D. TROUTMAN.