

D. C. FISHER.

Improvement in Washing-Machines.

No. 128,540.

Patented July 2, 1872.

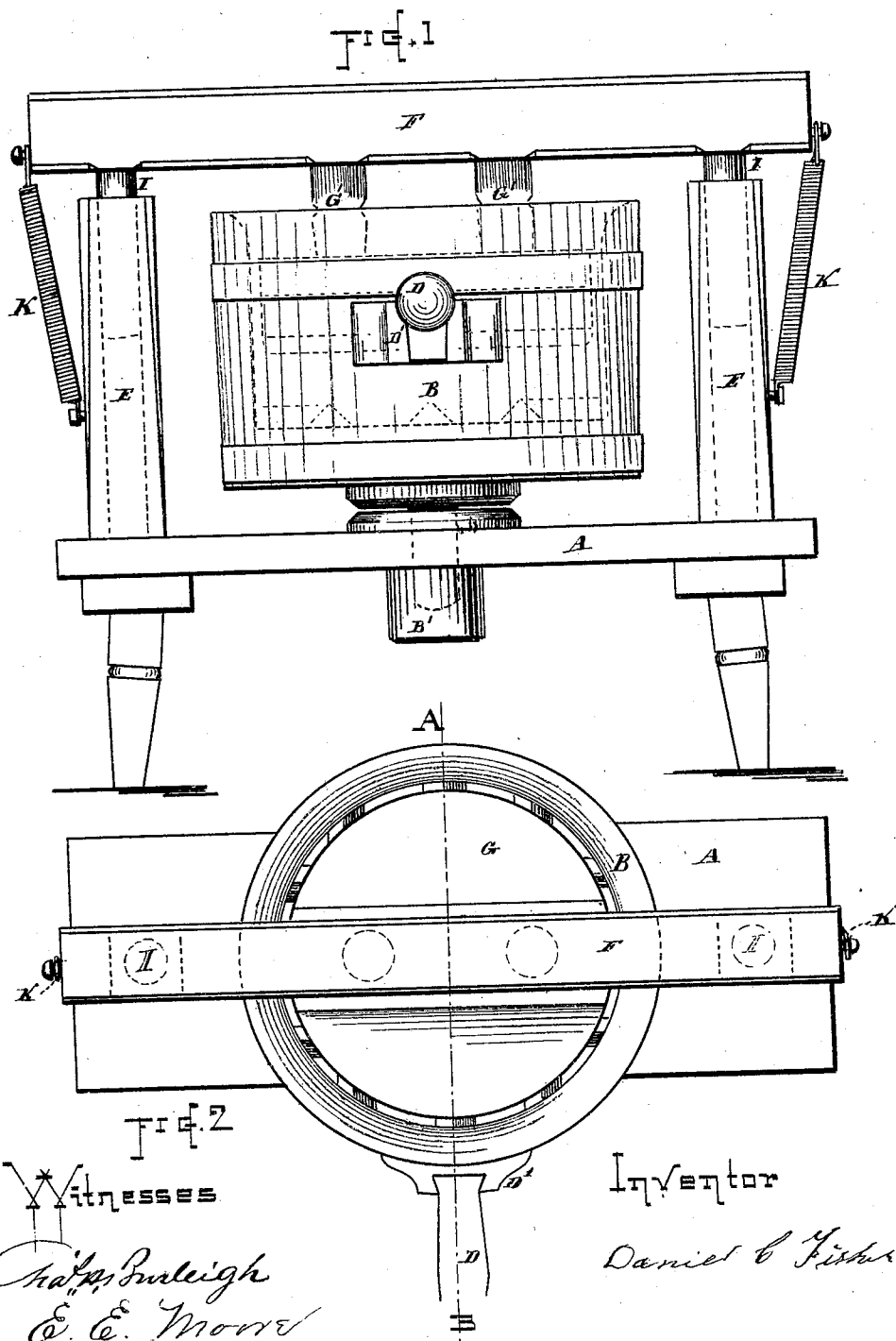

Witnesses

Chas. Bulleigh
E. E. Moore

Inventor

Daniel C. Fisher

D. C. FISHER.

Improvement in Washing-Machines.

No. 128,540.

Patented July 2, 1872.

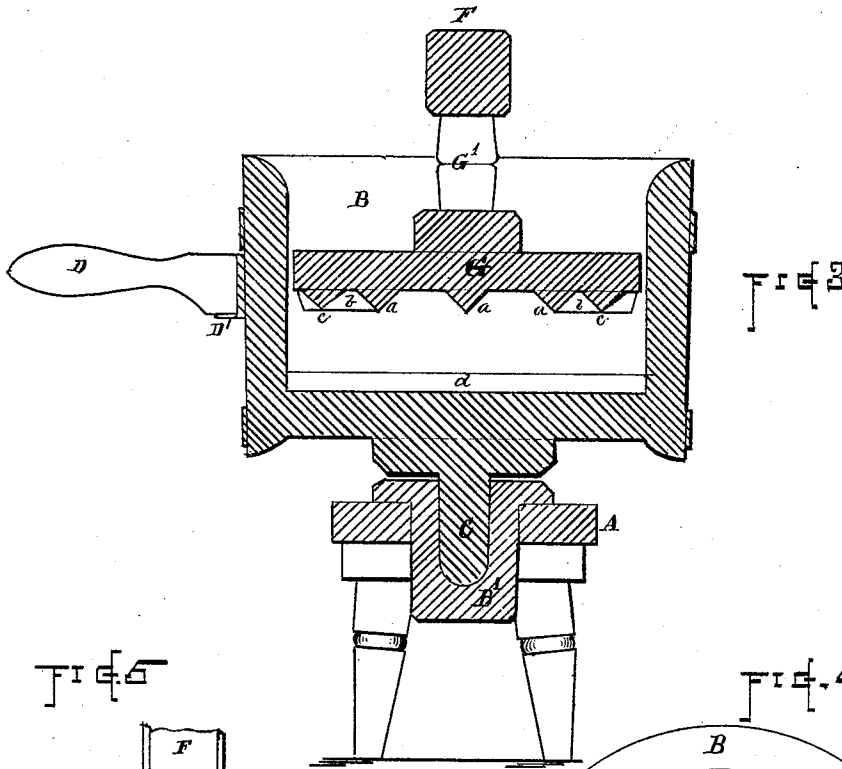
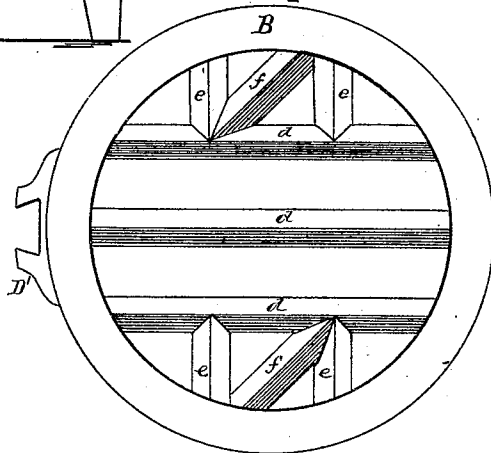
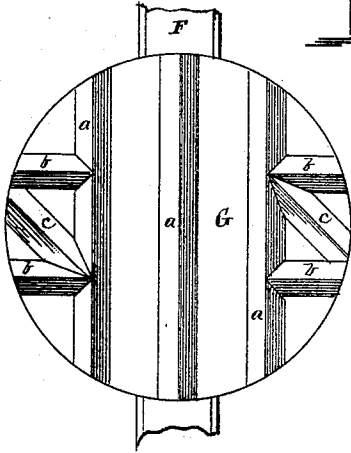

FIG. 3

FIG. 4



Witnesses

Inventor

Chas. Bowleigh
E. E. Moore

Daniel C. Fisher

UNITED STATES PATENT OFFICE.

DANIEL C. FISHER, OF WORCESTER, MASSACHUSETTS.

IMPROVEMENT IN WASHING-MACHINES.

Specification forming part of Letters Patent No. 128,540, dated July 2, 1872.

To all whom it may concern:

Be it known that I, DANIEL C. FISHER, of the city and county of Worcester and Commonwealth of Massachusetts, have invented certain new and useful Improvements in Washing-Machines; and I do hereby declare that the following is a full, clear, and exact description of the same, reference being had to the accompanying drawing which forms a part of this specification, and in which—

Figure 1 represents a front view of my improved washing-machine. Fig. 2 represents a plan view of the same. Fig. 3 represents a transverse vertical section at line A B, Fig. 1. Fig. 4 represents a view of the tub-bottom, showing the arrangement of the scrubbing-bars; and Fig. 5 represents the arrangement of the bars upon the under side of the scrubbing-disk.

The nature of my invention consists in the combination, with the rotating-tub, of the scrubbing-disk and follower-bar, as hereinafter described, and also in the peculiar arrangement of scrubbing-bars upon the tub-bottom and disk, whereby the clothes are prevented from collecting at the center of the tub.

In the drawing, the parts marked A represent the supporting-frame or bench. B indicates the tub which is furnished with a downward-projecting center pintle, C, which fits into a bearing piece, B¹, at the central part of the bench A, and supports the tub in such a manner that it can be oscillated or swung around horizontally on the pivot C, a handle, D, being attached to one side of the tub to facilitate the operation. The bearing piece B¹ and pintle C may be made of metal so that they will be durable, and operate with ease. The handle D is secured in position by means of a plate, D¹, which is screwed to the side of the tub, and to said plate D¹ the handle is fitted by a dovetailed recess into which the end of the handle is fitted in such a manner that it can readily be detached by raising it out of the recess. At the ends of the bench A are upright hollow standards E for supporting the follower-bar F, whereto the scrubbing-disk G is attached by means of the studs G¹. Downward-projecting pins I I are arranged near the

ends of the follower-bar F, which fit into the hollow standards E, and serve as guides to retain the follower-bar and disk in proper position. The disk G is made of the proper size to fit the interior of the tub B, as shown, and said disk is provided with ridges or scrubbing-bars upon its under side, which bars are made and arranged in this manner, illustrated in the drawing, Fig. 5, three parallel bars, *a*, being secured across the central part of the disk, and two short bars, *b*, at each side, set at right angles to the bars *a*, while a short diagonal bar, *c*, is arranged between each pair of the latter, as shown. Scrubbing-bars *d e f* are also arranged upon the tub-bottom in a similar manner to those upon the disk, as illustrated in Fig. 4, those upon the tub being so placed that when the disk is in working position the bars *a b c* of the disk will stand in a direction at right angles to the bars *d e f*, respectively. The scrubbing-disk G is pressed down upon the clothes when in use by springs K, one end of which are secured to the standards E, and the other to the ends of the follower-bar F. These springs may be of coiled wire or elastic bands.

The clothing to be washed is placed within the tub with a suitable quantity of soap and water, and the disk G and follower F placed in position, the disk resting on the clothing. The operator then, by taking hold of the handle D, oscillates the tub with a back and forward motion of the hand, and the clothing is quickly cleansed by the action of the scrubbing-bars on the disk and tub-bottom.

It will be observed that no central spindle or standard is used within the tub, so that the whole surface of the tub-bottom and disk is utilized, and the clothing can be equally distributed throughout the entire space between the bottom and disk, and there is nothing around which the clothes can entangle, while the peculiar arrangement of the bars *a b c* and *d e f* tend to prevent the clothing from rolling up into balls or wads, and also from collecting at the center of the tub, when the machine is in use.

In lieu of making the standards hollow and using the pins I for guiding the follower, said

standards may be provided with grooves or slots to receive the ends of the bar F, but I prefer the construction herein shown.

Having described my improved washing-machine, what I claim as new and of my invention, and desire to secure by Letters Patent, is—

The combination with the oscillating tub B

of the scrubbing-disk G, follower-bar F and its springs, and standards E, substantially as and for the purpose set forth.

DANIEL C. FISHER.

Witnesses:

CHAS. H. BURLEIGH,
E. E. MOORE.