

(19) World Intellectual Property Organization  
International Bureau



(43) International Publication Date  
9 November 2006 (09.11.2006)

PCT

(10) International Publication Number  
**WO 2006/117768 A1**

(51) International Patent Classification:  
*H04L 29/06* (2006.01) *G07F 7/10* (2006.01)

(74) Agents: **O'BRIEN, John, A.** et al.; c/o John. A. O'Brien & Associates, Third Floor, Duncairn House, 14 Carysfort Avenue, Blackrock, County Dublin (IE).

(21) International Application Number:  
PCT/IE2006/000045

(81) Designated States (unless otherwise indicated, for every kind of national protection available): AE, AG, AL, AM, AT, AU, AZ, BA, BB, BG, BR, BW, BY, BZ, CA, CH, CN, CO, CR, CU, CZ, DE, DK, DM, DZ, EC, EE, EG, ES, FI, GB, GD, GE, GH, GM, HR, HU, ID, IL, IN, IS, JP, KE, KG, KM, KN, KP, KR, KZ, LC, LK, LR, LS, LT, LU, LV, LY, MA, MD, MG, MK, MN, MW, MX, MZ, NA, NG, NI, NO, NZ, OM, PG, PH, PL, PT, RO, RU, SC, SD, SE, SG, SK, SL, SM, SY, TJ, TM, TN, TR, TT, TZ, UA, UG, US, UZ, VC, VN, YU, ZA, ZM, ZW.

(22) International Filing Date: 3 May 2006 (03.05.2006)

(25) Filing Language: English

(26) Publication Language: English

(30) Priority Data:  
2005/0270 3 May 2005 (03.05.2005) IE

(71) Applicant (for all designated States except US): **LINCOR SOLUTIONS LIMITED** [IE/IE]; Seabrook Technology Centre, Cork Technology Park, Model Farm Road, Cork (IE).

(84) Designated States (unless otherwise indicated, for every kind of regional protection available): ARIPO (BW, GH, GM, KE, LS, MW, MZ, NA, SD, SL, SZ, TZ, UG, ZM, ZW), Eurasian (AM, AZ, BY, KG, KZ, MD, RU, TJ, TM), European (AT, BE, BG, CH, CY, CZ, DE, DK, EE, ES, FI, FR, GB, GR, HU, IE, IS, IT, LT, LU, LV, MC, NL, PL, PT, RO, SE, SI, SK, TR), OAPI (BF, BJ, CF, CG, CI, CM, GA, GN, GQ, GW, ML, MR, NE, SN, TD, TG).

(72) Inventors; and

(75) Inventors/Applicants (for US only): **MURPHY, Enda** [IE/IE]; Belvedere House, Tower, County Cork (IE). **O'DONNELL, Patrick** [IE/IE]; 2 Inner Belmont, Rochestown Road, Cork (IE).

Published:  
— with international search report

[Continued on next page]

(54) Title: AN INFORMATION MANAGEMENT AND ENTERTAINMENT SYSTEM

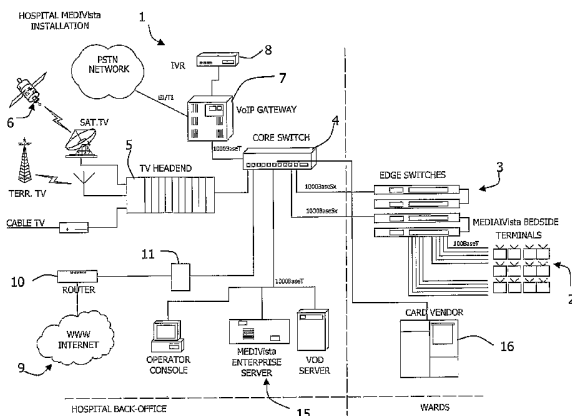

(57) Abstract: An information management and entertainment system (1) comprises user terminals (2), and a switching system (5, 40-43) having interfaces (21, 23, 31) for receiving media streams and for routing the streams to the terminals. The system (1) comprises at least one management server (15) for routing control signals to components of the system. The server (15) and the terminals (2) execute a middleware engine (65, 70) for communication within the system. The middleware engine comprises a services processor (65) executing on a server (15) and functions executing on the terminals (2) for controlling provision of information management and entertainment services to users via the terminals (2). The system further comprises at least one vending machine (16) for vending user cards for usage of services. The vending machine (16) writes a unique user identifier to each card, each terminal comprises a card reader, and the terminal (2) middleware functions receive and validate a card and allow provision of services upon validation of a card. The terminal middleware functions allow provision of services up to a limit set by a credit amount read from a card. The vending machine (16) writes the user identifier comprising a component having a card factory-set identifier and a component freshly-generated upon issuance of the card. The freshly-generated component is a value which is incremented from a previous value, and said value is not used again by the system.

WO 2006/117768 A1



---

*For two-letter codes and other abbreviations, refer to the "Guidance Notes on Codes and Abbreviations" appearing at the beginning of each regular issue of the PCT Gazette.*

“An Information Management and Entertainment System”

INTRODUCTION

5 Field of the Invention

The invention relates to an information and entertainment system for use by, for example, patients and clinicians in a hospital.

10 Prior Art Discussion

GB2384412 (Vortex Communications Limited) and GB2407891 (The Wandsworth Group Limited) describe systems in which terminals are used for a variety of information and entertainment services including television, telephone, internet,  
15 medical record access, and patient feedback services. Access to services is achieved using a card or key.

While there has been much development of hardware resources for such systems, there is a need to achieve improved versatility in terms of the range of information and  
20 entertainment services which can be provided. For example, the challenges faced in providing entertainment services (such as TV) is generally not compatible with clinicians interfacing with medical records using the same equipment because of the huge difference in data security requirements.

25 The invention is therefore directed towards providing an improved system having an interface for receiving diverse entertainment feed streams, an interface to extensive databases of high-security data such as medial records, and multiple terminals the users of which change frequently.

30 SUMMARY OF THE INVENTION

According to the invention, there is provided an information management and entertainment system comprising a plurality of user terminals, and a switching system

- 2 -

having interfaces for receiving media streams and for routing the streams to the terminals, characterized in that:

5 the system comprises at least one management server for routing control signals to components of the system,

the server and the terminals execute a middleware engine for communication within the system, and

10 the middleware engine comprises a services processor executing on a server and functions executing on the terminals for controlling provision of information management and entertainment services to users via the terminals.

15 In one embodiment, the system further comprises at least one vending machine for vending user cards for usage of services, wherein the vending machine writes a unique user identifier to each card, wherein each terminal comprises a card reader, wherein the terminal middleware functions receive and validate a card and allow provision of services upon validation of a card.

20 In one embodiment, the services processor automatically accesses data in an external database to verify a card.

In one embodiment, the terminal middleware functions allow provision of services up to a limit set by a credit amount read from a card.

25 In one embodiment, the vending machine writes the user identifier comprising a component having a card factory-set identifier and a component freshly-generated upon issuance of the card.

30 In one embodiment, the freshly-generated component is a value which is incremented from a previous value, and said value is not used again by the system.

- 3 -

In one embodiment, the vending machine comprises a receiver for receiving used cards, and a card issuer for re-issuing said cards with a different user identifiers.

5 In another embodiment, the services processor automatically terminates a user on the system upon return of the user's card.

10 In one embodiment, the services processor automatically terminates a user upon polling an external database of user data and if said external database indicates that the user should be terminated.

15 In one embodiment, the middleware engine services processor comprises a function executing on each terminal for validating a presented card, functions executing on the server and on the terminal for prompting input of user profile data to establish a user profile upon first presentation of a card, and middleware engine server functions identify the user by the card identifier.

20 In a further embodiment, the middleware engine services processor automatically maintains a transaction database, each record of which relates to a user service transaction.

In one embodiment, the middleware engine services processor automatically maintains a vendor log database, each record of which relates to a transaction involving a card vending machine, including a credit amount read from the card.

25 In one embodiment, the middleware engine services processor dynamically manages service provision to the terminals according to real time updating of the transaction and vendor log databases, writing of fresh records to these databases allowing provision of fresh services after validation by the middleware engine with reference to the user profile database.

30 In one embodiment, the middleware engine comprises a secure data processor having a function on each terminal for authorising access by a person having high-security

- 4 -

access, and functions executing on the server for allowing access to high-security data upon authorization by a terminal.

5 In one embodiment, said secure data processor limits high-security data access to database records associated with a user linked with the terminal (2) which receives the high-security data access request.

In one embodiment, the secure data processor determines said linking by verifying an association between a user and a terminal.

10

In one embodiment, said verification is performed by reference to the user profile database.

15 In one embodiment, the secure data processor validates a high-security card presented to a card reader in the terminal.

20 In one embodiment, the services processor comprises update functions executing on the terminals and on the vending machines, and said update functions automatically transmit live status updates to services processor functions executing on the server, and said functions log the updates.

In one embodiment, the updates are triggered according to time and according to service transaction or card vending events.

25 In one embodiment, the server-executing functions automatically parse the update to determine update data.

In one embodiment, server-executing functions use the updates to verify user-requested transactions.

30

In one embodiment, the services processor functions communicate within the system using the http protocol.

- 5 -

In one embodiment, the switching system comprises a local area network core switch and local area network edge switches linked with the terminals.

5 In one embodiment, the local area network core switch is connected to a TV head-end, in turn linked with broadcast networks, and said core switch is also connected to a VoIP gateway.

In one embodiment, the VoIP gateway is connected to an integrated voice response system.

10

## DETAILED DESCRIPTION OF THE INVENTION

### Brief Description of the Drawings

15 The invention will be more clearly understood from the following description of some embodiments thereof, given by way of example only with reference to the accompanying drawings in which:-

20

Fig. 1 is a block diagram of an information management and entertainment system of the invention;

Fig. 2 is a block diagram of a TV head-end part of the system;

Fig. 3 is a block diagram of a VoIP telephony part of the system; and

25

Fig. 4 is a flow diagram illustrating components of a middleware engine of the system and how they operate.

### Description of the Embodiments

30

#### System Overview

- 6 -

Referring to Fig. 1 an entertainment system 1 comprises multiple patient terminals 2 connected by 100BaseT cabling to local area network (LAN) edge switches 3, in turn connected to a LAN core switch 4. The LAN core switch 4 receives TV media inputs from a TV head-end 5, in turn receiving the media from various terrestrial and satellite sources 6. Also, a VoIP gateway 7 feeds voice to the LAN core switch 4, in turn receiving the voice signals from an IVR system 8 and a PSTN network. Internet access is via a router 10 and a firewall 11.

The system 1 further comprises a bank of enterprise servers 15, and smart card vending machines 16. There are multiple servers 15, interconnected for modular expansion and for redundancy. Also, while for clarity only one smart card vending machine 16 is shown, there are a number of vending machines 16 interconnected in a local area network at convenient locations in a hospital.

Each patient terminal 2 has a touch flat-screen configuration, is mounted on a swivel arm, and incorporates a processor, a telephone handset, and a smart card reader. The processor executes middleware functions as described below.

The system 1 in this embodiment provides the following services:

20

- Television (multiple channels, some digital IPTC protocol, some analog, and some encrypted).
- Digital radio.
- Internet Access – general purpose internet browsing with content filtering
- 25 • Films on demand (VOD services)
- Audio books
- Games.
- Telephone calls in/out
- Hospital Information pages
- 30 • Electronic Patient Records
- Electronic patient meal ordering
- Employee tracking

- 7 -

- Online shopping

These services are not an exhaustive list and a system of other embodiments may provide fewer or more services. An advantageous aspect of the invention is that a  
5 middleware engine executing on the servers 15, the terminals 2, and the vending machines 16 allows excellent versatility for real time modification of the range of services for any particular installation.

As illustrated in Fig. 1 the TV signals are received from any desired source, including  
10 digital satellite (DVB-S), digital terrestrial (DVB-T), or digital cable (DVB-C) sources. These signals are fed to the TV head-end 5 which receives, demodulates and streams the selected programs to the terminals 2 via the local area network. All of the TV signals are delivered using TV over IP multicasting technology.

15 Referring to Fig. 2, the method of reception and decoding of the TV programs is determined by which source they are transmitted from and if they require a conditional access system to decode them (i.e. are the signals scrambled). If the TV programs are transmitted in the clear, the signals (from DVB-S and DVB-T) are fed directly to an IPTV gateway 20. This is configured with the appropriate number of  
20 DVB-S 22 and DVB-T 21 PCI receiver cards depending on the configuration. Each card has the ability to tune into a single multiplex of programs. The IPTV gateway 20 is programmed to remove the appropriate TV programs from the multi-program transport stream being transmitted by the TV broadcaster and to repackage the selected programs into single-program transport streams. These single-program  
25 transport streams are then multi-casted on the LAN for reception by the terminals 2.

If the program to be received is scrambled prior to transmission, a conditional access decoder (with smart card authorization) is required to decode the program stream before re-transmission on the LAN. As many different types of conditional access  
30 exist, the system 1 employs IRDs (Integrated Receiver Decoders) 23 and set-top boxes 31. As the output of the IRDs 23 and set-top boxes 31 is generally analog video and audio, it is necessary to re-encode these channels into MPEG-2 format for re-transmission over the LAN. MPEG encoders 30 perform this function. These re-

- 8 -

encoded single-program transport streams are multi-casted on the LAN together with those program streams from the IPTV gateway 20. Reception of cable TV programs are dealt with in the same way as the conditional access channels.

- 5 The LAN uses IGMP-aware network switches to ensure minimal traffic on each node of the network.

The telephony system employs the VoIP (Voice over IP) protocol. The architecture of the telephony system is shown in Fig. 3. A VoIP gateway 40 is a SIP-based gateway  
10 that facilitates the conversion of SIP-based telephone calls to PSTN standards. Session Initiation Protocol (SIP) is a signalling standard suitable for handling converged communication.

An IVR (Integrated Voice Receiver) 41 acts as an automated attendant, automatically  
15 giving voice prompts to the caller to determine how to route the telephone call. This is primarily used during inbound telephone calls where the caller wishes to connect to a particular telephone extension number (patient terminal). The IVR 41 automatically answers the call and prompts the user for the desired extension number. The caller, using a terminal 2, dials the extension number using DTMF tones on their phone  
20 handset on the terminal. The IVR detects these DTMF tones and passes this information to the SIP gateway 40, which routes the call through to the correct destination. The PSTN 42 connections to the VoIP gateway 40 are PRI-30 telephone lines, the exact number required depending on the size and configuration of the installation.

25

Within the system 1 the main software execution platforms are the terminals 2, the servers 15, and the vending machines 16. The middleware engine executing on the servers 15 and the terminals 2 controls and monitors the information being  
30 transmitted, performs diagnostics, and monitors terminal 2 usage. It uses the core switch 4 as a hub for control and monitoring, the core switch 4 linking the entertainment and information services streams to the edge switches 3, in turn routing them to the terminals 2. There is bi-directional communication between the terminals

- 9 -

2 and the servers 15 and uni-directional communication between the servers 15 and the core switch 4 for control purposes.

5 The middleware engine handles the real time data streaming requirements across the wide variety of components of the system 1, including all terminals 2. This achieves uniform messaging for routing and other control purposes.

#### Vending Machine Operation and User Tracking

10 The vending machines 16 communicate with the servers 15 so that there can be full verification of all transactions requested at the vending machines 16. For example, a request for a refund for unused services accessed by use of a smart card involves a number of verification cycles. Such a cycle may involve an analysis of part usage pattern of the card and/or of particular services. The servers 15 also manage traffic to  
15 optimise off-peak usage of processing and communication resources within the system 1.

Regarding use of the vending machines 16, each card has a unique code, which code is automatically incremented with each transaction for purchase of services. This fresh  
20 code is stored on the card. The code comprises the unique factory-set code of the card and an addendum code. Thus, when a patient leaves the hospital and returns the card to a vending machine in return for a deposit refund the card is stored in the machine 16. This card will subsequently be re-issued to a fresh patient arriving in the hospital, this time with a code comprising the factory-set code and a fresh addendum, the  
25 combination being unique both at that time and across all historical use of the system 1. This code is the user code as far as the system 1 is concerned, and database user keys include this card code.

In more detail, each smart card has a unique 10 digit serial number programmed onto  
30 the card at the time of manufacture. The vending machine 16 appends a 6 digit number to the start of this serial number when it dispenses a card. Therefore the full serial number is as follows,

XXXXXXXXXXYYYYYY

- 10 -

where X represents the 10 digit hard coded serial number programmed at the time of card manufacture (and cannot be changed) and YYYYYY represents the serial number appended by the smart card vending machine. This YYYYYY serial number is incremented by one each time that a smart card is recycled through the vending machine, thus ensuring that the same serial number is never used twice in the system. It also facilitates the operator of the system to monitor how many times these smart cards are being recycled through the vending machines 16.

When a user purchases a smart card from the machine 16, the new serial number is generated on the card. When the user inserts this card into a terminal, a user database is checked to see if a record matching this serial number exists. If not, a new record is generated for this card (user). This is generated by the terminal prompting user input of profile data. The middleware engine automatically cross-checks the user profile data against the external hospital records. Thus, by input of a valid freshly-issued card, input of profile data, and cross-checking of the profile data against the external records there is comprehensive authentication of a user. If further security is required, the terminal may be programmed to require input of a supervisor security code to allow the profile data to be inputted. The terminals 2 interface directly with the external databases to interrogate them, after initially notifying the server-based middleware functions.

#### System Status Monitoring

The terminals 2 and the vending machines 16 regularly (once per minute) send out status information about themselves. This data gives live status information regarding status of the system components, and historical information regarding the usage of various services on the terminals by storing the information and data mining the results. With appropriate data monitoring, the system status data can help prevent problems from occurring, for example monitoring the cash levels in the vendor or monitoring storage disk usage on the terminals.

“Termon” is a dedicated client-server middleware function executing on each terminal 2 and on each vending machine 16, and which reports status data to a server 15, which

- 11 -

stores the data in a database. The corresponding server middleware function runs continuously on the server 15 and listens on a port for UDP packets coming from the machines 16 and terminals 2 on the network. When a packet arrives it is parsed, verified, and then written to the database. All data is stored in one large table for post-processing and some important data is also written to smaller tables for immediate access. The client-side function runs each minute. It collects the required pieces of information from the machine or terminal and builds a UDP packet with them. The packet has a very simple structure, the order of the fields is strictly defined and they are separated with new lines. This simplifies the parsing required at the server side and reduces server load. It also means that thousands of packets can still be reliably collected every minute even when the server is under heavy load from other tasks. The client function can also be triggered by certain key events taking place, such as when the phone handset is lifted, when a smart card is inserted, or if the user attempts to purchase a service but has insufficient credit to do so.

15

The table below lists each of the segments of data that are included in the termon data packet. Different packets are sent by the vendors and these are indicated also. When the termon data has been received and processed, it is stored in a termon database as shown below.

20

Field Name	Description	Terminal	Vendor
mac	MAC address of primary NIC	yes	yes
build	Lincor build number, e.g. 20060201512	yes	yes
card_id	ID number of inserted smart card	yes	no
credit	Available credit on inserted smart card	yes	no
case_temp	Ambient internal temperature in Celsius	yes	yes
cpu_temp	CPU temperature in Celsius	yes	yes
hdc1_pc	% disk usage on disk partition 1	yes	yes
hdc6_pc	% disk usage on disk partition 6	yes	yes
hdc7_pc	% disk usage on disk partition 7	yes	yes

- 12 -

Field Name	Description	Terminal	Vendor
ipaddr	IPv4 address of primary NIC	yes	yes
spare	spare field. unused.	no	no
load1	average system load over the last minute	yes	yes
load5	average system load over the last 5 mins	yes	yes
load15	average system load over the last 15 mins	yes	yes
memtotal	Total memory in system (KB)	yes	yes
memused	Used memory in system (KB)	yes	yes
type	“terminal” or “vendor”	yes	yes
memfree	Free, unused memory (KB)	yes	yes
timestamp	Unix epoch timestamp of data packet	yes	yes
previous_uri	Previous URI loaded by browser	yes	no
current_uri	Current URI loaded by browser	yes	no
change10_avail	10 cent coins in hopper	no	yes
change100_avail	100 cent coins in hopper	no	yes
cards_avail	Blank cards in hopper	no	yes
outoforder	Out Of Order	no	yes
paperlow	Receipt roll at <25%	no	yes
nopaper	Receipt roll empty	no	yes
changelow	change below danger mark	no	no
nocards	No blank cards available	no	yes
dooropen	Service door open	no	yes
magicbutton	Magic button pressed	no	yes
staticdatacount	Reported data unchanged for X minutes	yes	yes

Database Structure and Server Interaction

- 13 -

The main database of the servers 15 includes the following tables.

*vend\_log* table

5 This is where all vendor transactions are logged.

	<u>date</u>	Date and time that the transaction was logged.
	<u>vendor_id</u>	The assigned site-specific ID assigned to a vending machine when it is commissioned.
10	<u>vendor_transaction</u>	The identifier ID of the transaction that will correspond to the logged transaction.
	<u>type</u>	The transaction type describes and identifies the transaction that is recorded in both the vendor log and the server database <i>vend_log</i> table.
15	<u>card_id</u>	The unique card ID, made up of the manufacturer ID and the usage counter, as described above. This provides a unique <i>card_id</i> whenever a card is vended.
	<u>cash_taken</u>	The amount that was put into the vending machine through the coin mechanism and the note mechanism.
20	<u>cash_paid</u>	The value of the coins returned through the coin hoppers to the patient either as a result of overpayment, a cancelled transaction or because of the refund.
	<u>credit_note_value</u>	The value of any credit note issue to a patient when insufficient coins were available.
25	<u>donation_value</u>	The amount that was donated by the patient from a refunded card.
	<u>card_value_added</u>	The value that has been credited to the card.
	<u>card_value_taken</u>	The value of credit that has been removed from the card due to a refund.

30

- 14 -

*card\_ticket* table

This is a table that logs transactions, “tickets”, to cards. This table holds duplicate data to the ticket table.

5	<u>ticket_id</u>	Unique ID for the ticket assigned by the database when the entry is made.
	<u>card_id</u>	The card_id to which the ticket is attached.
	<u>uri</u>	The service that is being bought.
	<u>start</u>	The start time of the service.
10	<u>duration</u>	The duration for which the ticket is valid.
	<u>rate</u>	The cost of the service.
	<u>charge_type</u>	The type of charge applied.

*card* table

15 The table that holds card registration details.

	<u>card_id</u>	The unique ID of the card
	<u>date_first_used</u>	The data and time of the card was first entered into the terminal.
20		

*card\_user* table

This table is used to map the smart card to the user\_id, the value used internally in the database to identify a set of transactions.

25	<u>card_id</u>	The unique ID of the card
	<u>user_id</u>	A unique ID for the user of the card assigned by the database.

- 15 -

***bed\_user table:***

This table is used to hold a mapping between the bed the patient is in and the user\_id which identifies the set of transactions. It is a specific example for a hospital installation. More generally, this table associates terminals with user identifiers.

5

<u>bed_id</u>	A bed ID as defined when a terminal is commissioned and input at that point into the database
<u>user_id</u>	A unique ID for the user of the card assigned by the database.

10

***user table***

The user table is used to store the profile information about the users. It is not updated as frequently as those tables which record transaction data, and should be regarded as static during the time duration of a particular user being active on the system 1, in this installation the time duration of a patient being in the hospital.

15

<u>user_id</u>	The database primary key for a user as described and assigned above.
<u>surname</u>	Surname of a patient.
<u>forename</u>	Forename of a patient
<u>date_of_birth</u>	Date of birth of a patient.
<u>date_of_registration</u>	Date the user was first registered in the database.
<u>do_not_disturb</u>	A flag to indicate that a patient should not be disturbed
<u>busy</u>	The patient is busy, not used.
<u>parental_guidance</u>	Classification of the patient for service delivery.
<u>pin_number</u>	Not used in this embodiment
<u>ddi_number</u>	The analog or digital telephone number and extension for the user.
<u>gone_home</u>	Notification that the patient is no longer in the hospital.

20

25

30

- 16 -

***ticket table***

All current valid tickets are entered in the ticket table. When a ticket is bought (credit purchased on a card using a vending machine 16) on a terminal this table is updated with the pertinent information.

5

<u>ticket_id</u>	Unique ID for the ticket assigned by the database when the entry is made.
<u>user_id</u>	The user_id to which the ticket is attached.
<u>uri</u>	The service that is being bought.
10 <u>start</u>	The start time of the service.
<u>duration</u>	The duration for which the ticket is valid.
<u>rate</u>	The cost of the service.
<u>charge_type</u>	The type of charge applied, generally a ticket.

15 ***old\_ticket table***

Invalid out-of-data tickets are moved to the old\_ticket table by a process run once daily on the server.

20 <u>ticket_id</u>	Unique ID for the ticket assigned by the database when the entry is made.
<u>user_id</u>	The user_id to which the ticket is attached.
<u>uri</u>	The service that is being bought.
<u>start</u>	The start time of the service.
<u>duration</u>	The duration for which the ticket is valid.
25 <u>rate</u>	The cost of the service.
<u>charge_type</u>	The type

***ticket\_log table***

This is a log of all tickets old and new. It is a view of the ticket data and holds no extra  
30 information. It is not used by any verification or validation process, it is used for logging purposes only.

**bed table**

The bed table is populated when a system is commissioned. The data is used to identify and describe a particular bedside terminal.

5

bed_id	This is the assigned bed_id for
bed_number	An external reference to a bedside terminal configuration database.
phone_extension	The phone extension of the bedside terminal.
10 ward_id	The ward identification.

The vending machines 16 use the http protocol to access the server database. A http “get request” is sent to a PHP page on the server. This page has write access to the database and the following fields are written into the vendor\_log table in the database  
15 when a transaction on the vendor has finished:

The transaction type describes and identifies the transaction that is recorded in both the vending machine log and the server database vend\_log table. The type will be one of the following:

20

sale	A new card ID, made up of the manufacture ID and the usage number, is created that has a defined credit value.
topup	A valid card ID has had its credit added to by a defined amount.
25 refund	A valid card ID has had all its credit refunded to the patient and the card id is now no longer valid.
donate	A valid card ID has had all its credit donated by the patient and the card ID is now no longer valid.
drain	A vendor has had its hopper drained of coins by a 30 service person.
nosale	A cancelled transaction took place, a card ID may have been provided if available.

- 18 -

If the server 15 is not available then the vending machine 16 will not allow any transactions to take place. This is achieved using an asynchronous process that actively polls the network for the server and if no response to the poll is achieved then the server is assumed to be unavailable and the vending machine 16 goes off-line and becomes "Out of service" for patient transactions. There is also an independent usage log on each vending machine 16 that can be used to reconstruct any "lost" transactions. The usage log should match the data written to the database on the server.

10

After a patient buys a card with credit they can use the credit electronically stored on the card to buy "tickets" for services provided by a terminal at their bedside. Services like television, Internet access, telephone call time and movies can be purchased. The ticket is only valid for the card that was used to purchase it. The card that purchased a ticket must be present, inserted into the terminal, to allow the patient to access the service. Multiple tickets can be purchased by a patient. They may have a 24 hour ticket to watch TV, a ticket to view a movie and be on a telephone call all at the same time. When a new ticket is entered in the database the ticket table is updated with the following information:

20

<u>ticket_id</u>	Unique id for the ticket assigned by the database when the entry is made.
<u>card_id</u>	The card_id to which the ticket is attached.
<u>uri</u>	The service that is being bought
<u>start</u>	The start time of the service
<u>duration</u>	The duration for which the ticket is valid
<u>rate</u>	The cost of the service
<u>charge_type</u>	The type of charge applied, generally a ticket

25

30 When a card is first put in a unit the following information is put in the database in the card table:

<u>card_id</u>	The unique ID of the card
----------------	---------------------------

- 19 -

date\_first\_used      The data and time of the card was first entered into the bedside terminal.

and an entry is made in the card\_user table:

5

card\_id              The unique ID of the card  
user\_id              A unique ID for the user of the card assigned by the database.

10 and an entry is made in the bed\_user table:

bed\_id              A bed ID as defined when a terminal is commissioned and input at that point into the database

user\_id              A unique ID for the user of the card assigned by the database.

15

When a card is taken from one terminal to another the bed\_user table is updated to match the new information.

20 The user table holds data that is associated with the user\_id that may be requested from a user directly as a registration exercise at first use of a smartcard in a bedside terminal or by cross referenced from other hospital systems like checkin and checkout data (this is not implemented yet). The user table holds the following data:

25      user\_id              The database primary key for a user as described and assigned above.

surname              Surname of a patient.

forename              Forename of a patient

date\_of\_birth        Date of birth of a patient.

30      date\_of\_registration      Date the user was first registered in the database.

do\_not\_disturb      A flag to indicate that a patient should not be disturbed

busy                  The patient is busy, not used.

parental\_guidance      Classification of the patient for service delivery.

- 20 -

<u>pin_number</u>	Not used in this embodiment.
<u>ddi_number</u>	The analog or digital telephone number and extension for the user.
<u>gone_home</u>	Notification that the patient is no longer in the hospital.

5

The database also has an "Old ticket table", tickets are relegated to this table when they are no longer valid. This is done once a day by a script on the server that runs at 3:50 am. This provides a clear view of valid tickets when looking at a view of ticket table.

10

#### Middleware Engine Operation

The middleware engine executing on the servers 15 and the terminals 2 and the vending machines 16 performs the operations described above for providing services.

15

A user registration with the system 1 is automatically terminated when the card is returned to a vending machine 16. When the user inserts the card for return of a deposit, a middleware function on the vending machine automatically generates a notification for the functions executing on the server 15. These functions update the user profile database to indicate that the user is terminated on the system 1. If the card is not returned by the user, an administration user having administration security access performs this update. Alternatively, a middleware function on the server 15 automatically terminates users according to polling of the external medical databases to retrieve data concerning patients who have left the hospital.

25

The system 1 also operates to allow clinicians to access medial records using the terminals 2. Fig. 4 illustrates an overview. As described above there is real time updating, indicated by the arrows 62 and 63, of the ticket table (60 in this drawing) and the vendor log table (61 in this drawing) as transactions take place. The link between these tables is the card identifier, as this uniquely identifies the user. The user table (66 in this drawing) is relatively static, storing the user profile. The middleware engine, at a general level, comprises a services processor 65 and a secure data processor 70. Synchronized operation of the processors 65 and 70 allow the terminals

30

- 21 -

2 to be used for the diverse tasks of providing entertainment and information  
management services to the users, such as TV, radio, internet access, or video games  
as described above. Clearly, data updating by a clinician such as a doctor or a nurse, is  
very different. The system 1 achieves such joint use by the services processor 65  
5 accessing the tables including the tables 60, 61, and 66 and executing the status update  
“termon” programs. The secure data processor 70 operates independently to access  
secure high-data-security medical records 75 on external databases, which records are  
not accessible to the services processor 65. However, there is overall synchronisation  
because the secure data processor 70 interacts with the services processor 65 to fetch  
10 user profile data from the table 66. The security for clinician access is driven by a  
clinician security card being inserted in the terminal, and the processor 70 performing  
access control operations on the basis of this card access and also inputting of security  
codes. Again, this is independent of the user access control operations. Thus, while the  
same terminal is used for inputting data and the same database tables provide user  
15 profile data, the data updating and access control operations are independent.

It will be appreciated that the invention provides a system for comprehensive  
provision of information management and entertainment services in real time despite  
the complexity of having transient users and disparate uses involving highly  
20 confidential data access and entertainment provision.

The invention is not limited to the embodiments described but may be varied in  
construction and detail. For example, the system may be used for applications other  
than hospitals, such as nursing homes or hotels. Also, the system may not include card  
25 vending machines, an all terminal authentication may be by way of inputted security  
codes or biometrics. In this case the users may be billed by the server, such as when  
leaving.

Claims

1. An information management and entertainment system comprising a plurality of user terminals (2), and a switching system (5, 40-43) having interfaces (21, 23, 31) for receiving media streams and for routing the streams to the terminals, characterized in that:
- the system (1) comprises at least one management server (15) for routing control signals to components of the system,
- the server (15) and the terminals (2) execute a middleware engine (65, 70) for communication within the system, and
- the middleware engine comprises a services processor (65) executing on a server (15) and functions executing on the terminals (2) for controlling provision of information management and entertainment services to users via the terminals (2).
2. An information management and entertainment system as claimed in claim 1, wherein the system further comprises at least one vending machine (16) for vending user cards for usage of services, wherein the vending machine (16) writes a unique user identifier to each card, wherein each terminal comprises a card reader, wherein the terminal (2) middleware functions receive and validate a card and allow provision of services upon validation of a card.
3. An information management and entertainment system as claimed in claim 2, wherein the services processor automatically accesses data in an external database (75) to verify a card.
4. An information management and entertainment system as claimed in claims 2 or 3, wherein the terminal middleware functions allow provision of services up to a limit set by a credit amount read from a card.

- 23 -

5. An information management and entertainment system as claimed in any of claims 2 to 4, wherein the vending machine (16) writes the user identifier comprising a component having a card factory-set identifier and a component freshly-generated upon issuance of the card.
- 5
6. An information management and entertainment system as claimed in claim 5, wherein the freshly-generated component is a value which is incremented from a previous value, and said value is not used again by the system.
- 10
7. An information management and entertainment system as claimed in any of claims 2 to 6, wherein the vending machine (16) comprises a receiver for receiving used cards, and a card issuer for re-issuing said cards with a different user identifiers.
- 15
8. An information management and entertainment system as claimed in claim 7, wherein the services processor (65) automatically terminates a user on the system upon return of the user's card.
- 20
9. An information management and entertainment system as claimed in claim 8 wherein the services processor (65) automatically terminates a user upon polling an external database of user data and if said external database indicates that the user should be terminated.
- 25
10. An information management and entertainment system as claimed in any preceding claim, wherein the middleware engine services processor (65) comprises a function executing on each terminal (2) for validating a presented card, functions executing on the server (15) and on the terminal (2) for prompting input of user profile data to establish a user profile upon first presentation of a card, and middleware engine server functions identify the user by the card identifier.
- 30

- 24 -

11. An information management and entertainment system as claimed in any preceding claim, wherein the middleware engine services processor automatically maintains a transaction database (60), each record of which relates to a user service transaction.
- 5
12. An information management and entertainment system as claimed in claim 11, wherein the middleware engine services processor (65) automatically maintains a vendor log database (61), each record of which relates to a transaction involving a card vending machine (16), including a credit amount read from the card.
- 10
13. An information management and entertainment system as claimed in claim 12, wherein the middleware engine services processor (65) dynamically manages service provision to the terminals (2) according to real time updating of the transaction and vendor log databases (60, 61), writing of fresh records to these databases allowing provision of fresh services after validation by the middleware engine with reference to the user profile database (66).
- 15
14. An information management and entertainment system as claimed in any preceding claim, wherein the middleware engine comprises a secure data processor (70) having a function on each terminal (2) for authorising access by a person having high-security access, and functions executing on the server for allowing access to high-security data upon authorization by a terminal.
- 20
15. An information management and entertainment system as claimed in claim 14, wherein said secure data processor (70) limits high-security data access to database records associated with a user linked with the terminal (2) which receives the high-security data access request.
- 25
16. An information management and entertainment system as claimed in claim 15, wherein the secure data processor (70) determines said linking by verifying an association between a user and a terminal (2).
- 30

- 25 -

17. An information management and entertainment system as claimed in claim 16, wherein said verification is performed by reference to the user profile database. (66).
- 5 18. An information management and entertainment system as claimed in any of claims 14 to 17, wherein the secure data processor validates a high-security card presented to a card reader in the terminal.
- 10 19. An information management and entertainment system as claimed in any of claims 2 to 18, wherein the services processor comprises update functions executing on the terminals (2) and on the vending machines (16), and said update functions automatically transmit live status updates to services processor functions executing on the server (15), and said functions log the updates.
- 15 20. An information management and entertainment system as claimed in claim 19, wherein the updates are triggered according to time and according to service transaction or card vending events.
- 20 21. An information management and entertainment system as claimed in claims 19 or 20, wherein the server-executing functions automatically parse the update to determine update data.
- 25 22. An information management and entertainment system as claimed in any of claims 19 to 21, wherein server-executing functions use the updates to verify user-requested transactions.
- 30 23. An information management and entertainment system as claimed in any preceding claim, wherein the services processor (65) functions communicate within the system using the http protocol.
24. An information management and entertainment system as claimed in any preceding claim, wherein the switching system comprises a local area network

- 26 -

core switch (4) and local area network edge switches (3) linked with the terminals (2).

- 5 25. An information management and entertainment system as claimed in claim 24, wherein the local area network core switch (4) is connected to a TV head-end (5), in turn linked with broadcast networks, and said core switch is also connected to a VoIP gateway (7).
- 10 26. An information management and entertainment system as claimed in claim 25, wherein the VoIP gateway is connected to an integrated voice response system (8).
- 15 27. A computer readable medium comprising software code for performing operations of a middleware engine of a system of any preceding claim when executing on a digital processor.

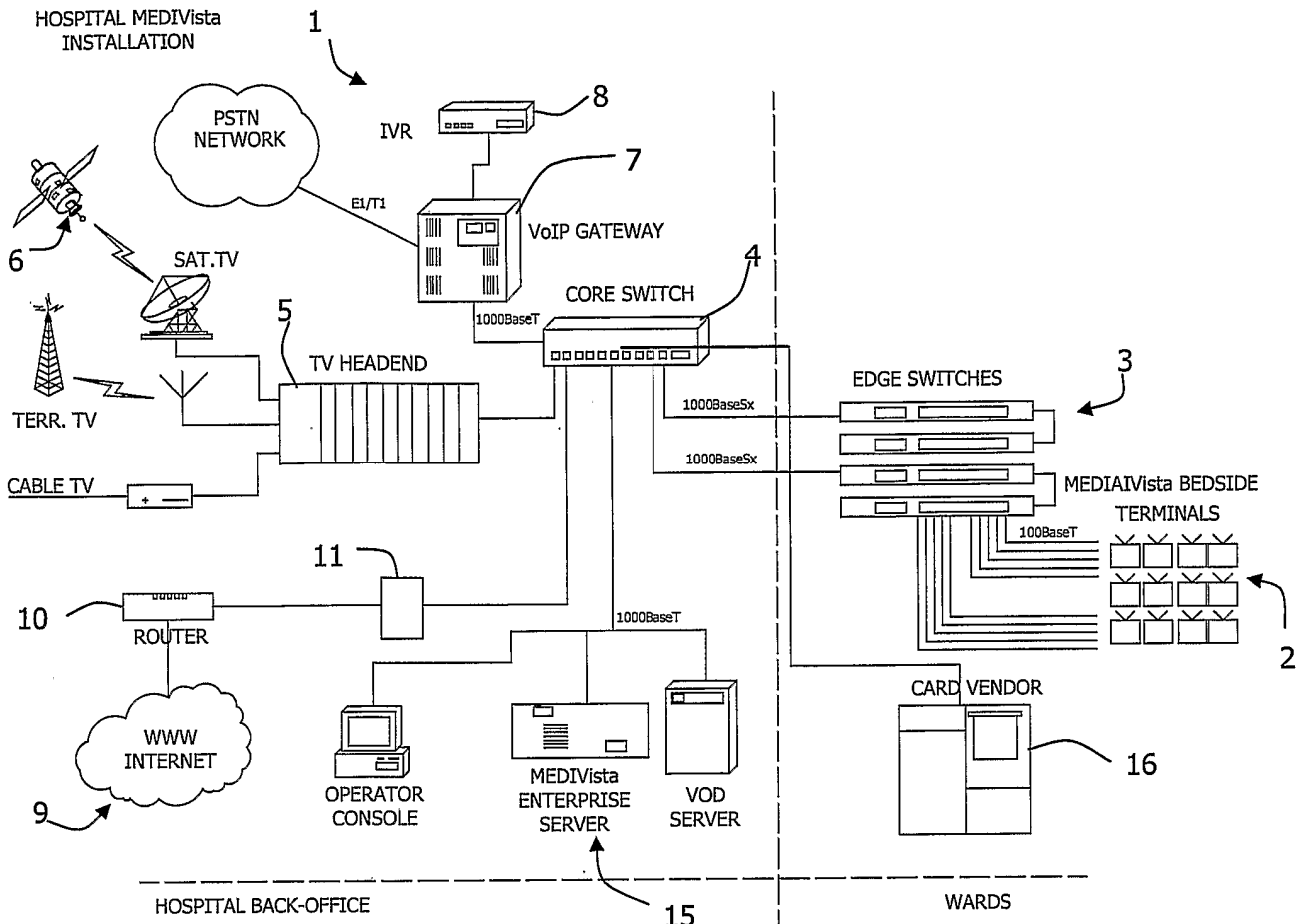

Fig.1

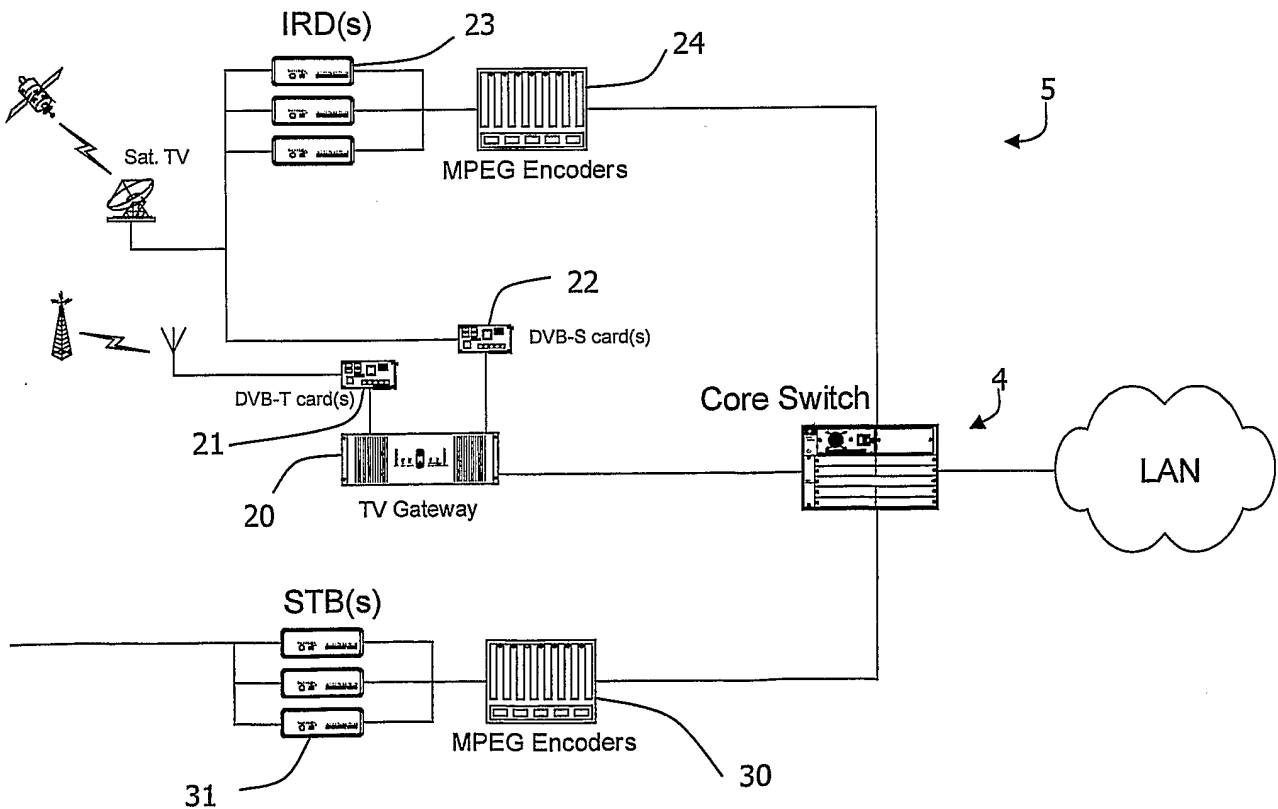

Fig.2

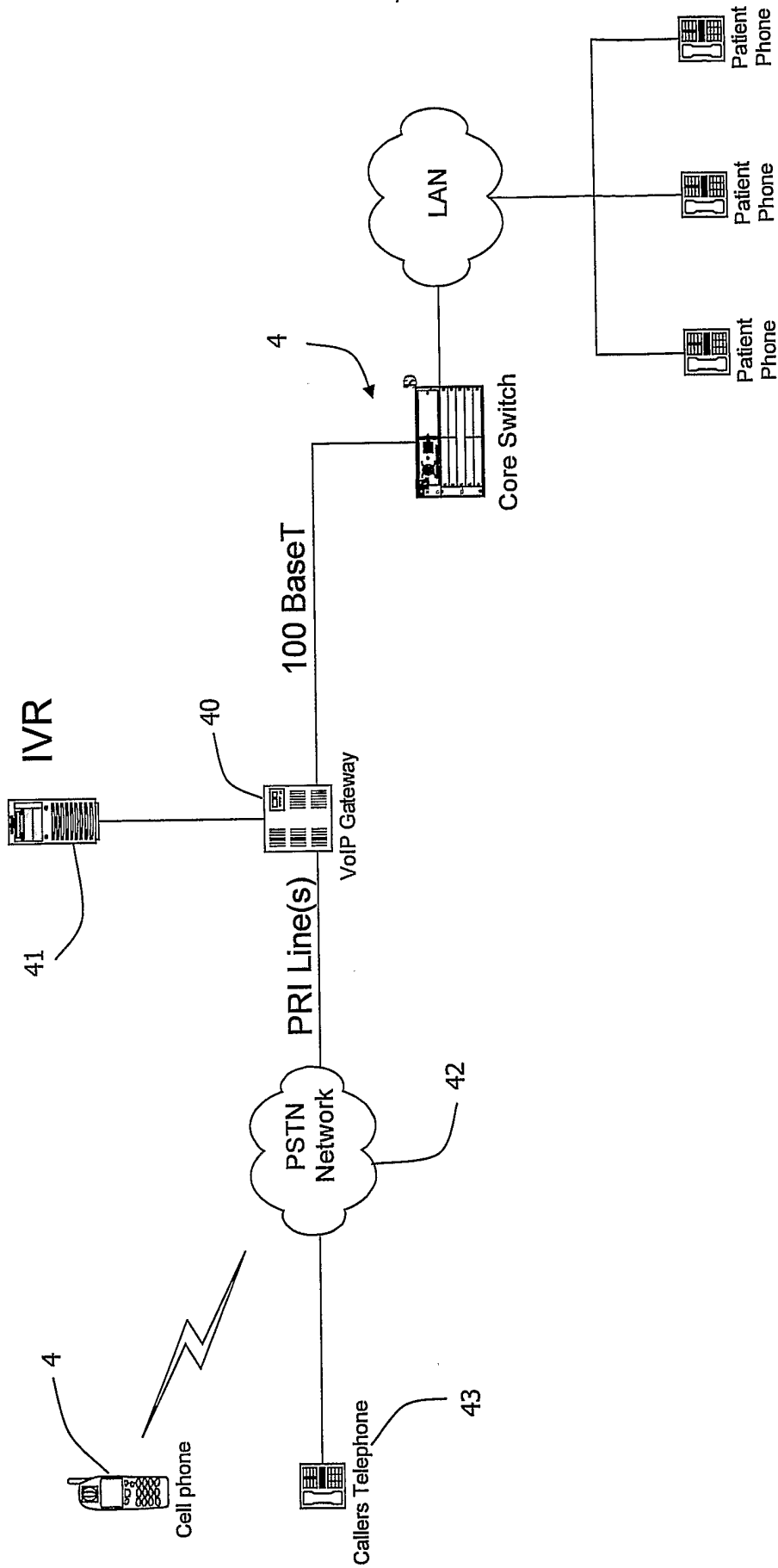

Fig.3

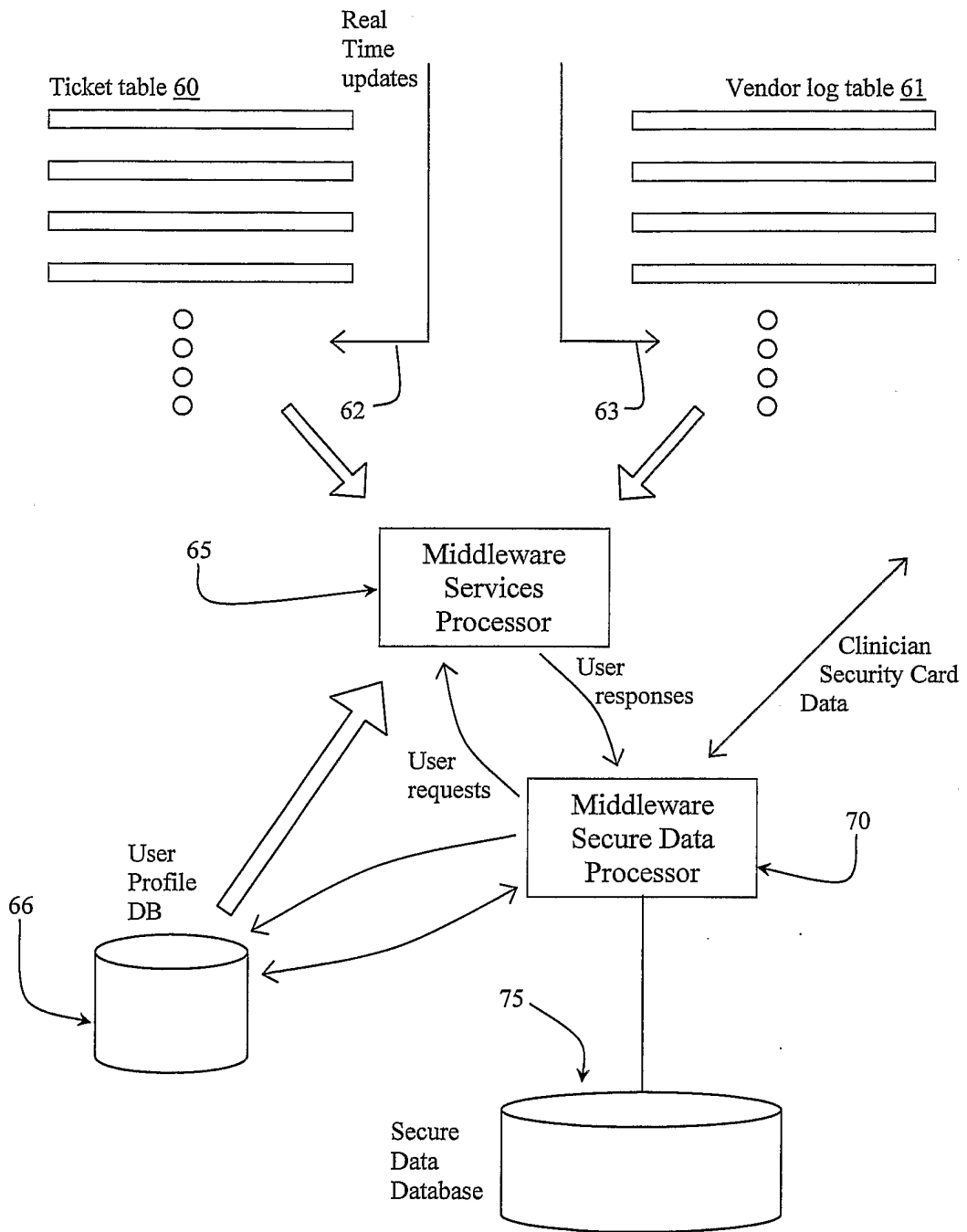

Fig. 4

**INTERNATIONAL SEARCH REPORT**

International application No  
PCT/IE2006/000045

**A. CLASSIFICATION OF SUBJECT MATTER**  
INV. H04L29/06 G07F7/10

According to International Patent Classification (IPC) or to both national classification and IPC

**B. FIELDS SEARCHED**

Minimum documentation searched (classification system followed by classification symbols)  
H04L G07F

Documentation searched other than minimum documentation to the extent that such documents are included in the fields searched

Electronic data base consulted during the international search (name of data base and, where practical, search terms used)

EPO-Internal

**C. DOCUMENTS CONSIDERED TO BE RELEVANT**

Category*	Citation of document, with indication, where appropriate, of the relevant passages	Relevant to claim No.
X	FR 2 760 158 A (NETGEM) 28 August 1998 (1998-08-28) page 1, line 12 - page 2, line 5	1-3,27
A	page 3, line 15 - page 6, line 23; figure 1	4-26
X	EP 1 191 742 A (CELTIPHARM.COM SA) 27 March 2002 (2002-03-27)	1,27
A	paragraphs [0006], [0007], [0015], [0016], [0020] - [0022]	2-26
A	WO 01/08055 A (SECURECOM LTD; TAYLOR, BARRY, JOHN; GROSVENOR LEISURE INCORPORATED) 1 February 2001 (2001-02-01) page 2, line 9 - line 17 page 3, line 17 - page 4, line 3 page 8, line 5 - line 21 page 9, line 13 - page 10, line 18	4,11,12
	-/--	

Further documents are listed in the continuation of Box C.

See patent family annex.

\* Special categories of cited documents :

- "A" document defining the general state of the art which is not considered to be of particular relevance
- "E" earlier document but published on or after the international filing date
- "L" document which may throw doubts on priority claim(s) or which is cited to establish the publication date of another citation or other special reason (as specified)
- "O" document referring to an oral disclosure, use, exhibition or other means
- "P" document published prior to the international filing date but later than the priority date claimed

- "T" later document published after the international filing date or priority date and not in conflict with the application but cited to understand the principle or theory underlying the invention
- "X" document of particular relevance; the claimed invention cannot be considered novel or cannot be considered to involve an inventive step when the document is taken alone
- "Y" document of particular relevance; the claimed invention cannot be considered to involve an inventive step when the document is combined with one or more other documents, such combination being obvious to a person skilled in the art.
- "&" document member of the same patent family

Date of the actual completion of the international search

13 July 2006

Date of mailing of the international search report

19/07/2006

Name and mailing address of the ISA/  
European Patent Office, P.B. 5818 Patentlaan 2  
NL - 2280 HV Rijswijk  
Tel. (+31-70) 340-2040, Tx. 31 651 epo nl,  
Fax: (+31-70) 340-3016

Authorized officer

Ceccarini, G

## INTERNATIONAL SEARCH REPORT

International application No  
PCT/IE2006/000045

C(Continuation). DOCUMENTS CONSIDERED TO BE RELEVANT		
Category*	Citation of document, with indication, where appropriate, of the relevant passages	Relevant to claim No.
A	WO 98/47112 A (STRATEX/PARADIGM LIMITED; NON CAN JAM TRADING (PTY) LIMITED; MILLER,) 22 October 1998 (1998-10-22) page 2, line 10 - page 3, line 7 page 8, line 8 - page 12, line 15 -----	1-27
A	WO 01/16900 A (AMERICAN EXPRESS TRAVEL RELATED SERVICES COMPANY,) 8 March 2001 (2001-03-08) page 3, line 20 - page 4, line 16 page 6, line 31 - page 8, line 27 -----	1-27

## INTERNATIONAL SEARCH REPORT

Information on patent family members

International application No

PCT/IE2006/000045

Patent document cited in search report		Publication date	Patent family member(s)	Publication date
FR 2760158	A	28-08-1998	AT 231629 T	15-02-2003
			AU 6406198 A	09-09-1998
			DE 69810888 D1	27-02-2003
			EP 0928445 A1	14-07-1999
			WO 9837479 A1	27-08-1998
EP 1191742	A	27-03-2002	FR 2814621 A1	29-03-2002
WO 0108055	A	01-02-2001	NONE	
WO 9847112	A	22-10-1998	AU 7061098 A	11-11-1998
			EP 1010148 A1	21-06-2000
WO 0116900	A	08-03-2001	AT 258328 T	15-02-2004
			AU 775976 B2	19-08-2004
			AU 7090700 A	26-03-2001
			AU 2004231226 A1	23-12-2004
			BR 0013822 A	23-07-2002
			CA 2382922 A1	08-03-2001
			CN 1376292 A	23-10-2002
			CZ 20020744 A3	18-02-2004
			DE 60007883 D1	26-02-2004
			DE 60007883 T2	14-10-2004
			DK 1212732 T3	07-06-2004
			EP 1212732 A2	12-06-2002
			ES 2215064 T3	01-10-2004
			HK 1048550 A1	21-10-2004
			HR 20020180 A2	30-06-2004
			HU 0202471 A2	28-11-2002
			JP 2003508838 T	04-03-2003
			MA 27459 A1	01-08-2005
			MX PA02002081 A	30-07-2004
			NO 20020996 A	24-04-2002
NZ 517840 A	24-03-2005			
PL 353773 A1	01-12-2003			
PT 1212732 T	30-06-2004			
TR 200201280 T2	21-08-2002			
TR 200202436 T2	21-01-2003			
TW 548564 B	21-08-2003			