



(51) International Patent Classification:

F03D 1/06 (2006.01) F03D 9/25 (2016.01)
F03D 9/16 (2016.01) F03D 9/14 (2016.01)

(21) International Application Number:

PCT/CA2018/050897

(22) International Filing Date:

25 July 2018 (25.07.2018)

(25) Filing Language:

English

(26) Publication Language:

English

(30) Priority Data:

2,974,440 25 July 2017 (25.07.2017) CA

(72) Inventor; and

(71) Applicant: BARBAN, Reno [CA/CA]; 379 Lake Street, Apt 209, Sault Ste. Marie, Ontario P6B 3K7 (CA).

(74) Agent: BOWN, Christopher et al.; GOWLING WLG (CANADA) LLP, Suite 2600, 160 Elgin Street, Ottawa, Ontario K1P 1C3 (CA).

(81) Designated States (unless otherwise indicated, for every kind of national protection available): AE, AG, AL, AM,

AO, AT, AU, AZ, BA, BB, BG, BH, BN, BR, BW, BY, BZ, CA, CH, CL, CN, CO, CR, CU, CZ, DE, DJ, DK, DM, DO, DZ, EC, EE, EG, ES, FI, GB, GD, GE, GH, GM, GT, HN, HR, HU, ID, IL, IN, IR, IS, JO, JP, KE, KG, KH, KN, KP, KR, KW, KZ, LA, LC, LK, LR, LS, LU, LY, MA, MD, ME, MG, MK, MN, MW, MX, MY, MZ, NA, NG, NI, NO, NZ, OM, PA, PE, PG, PH, PL, PT, QA, RO, RS, RU, RW, SA, SC, SD, SE, SG, SK, SL, SM, ST, SV, SY, TH, TJ, TM, TN, TR, TT, TZ, UA, UG, US, UZ, VC, VN, ZA, ZM, ZW.

(84) Designated States (unless otherwise indicated, for every kind of regional protection available): ARIPO (BW, GH, GM, KE, LR, LS, MW, MZ, NA, RW, SD, SL, ST, SZ, TZ, UG, ZM, ZW), Eurasian (AM, AZ, BY, KG, KZ, RU, TJ, TM), European (AL, AT, BE, BG, CH, CY, CZ, DE, DK, EE, ES, FI, FR, GB, GR, HR, HU, IE, IS, IT, LT, LU, LV, MC, MK, MT, NL, NO, PL, PT, RO, RS, SE, SI, SK, SM, TR), OAPI (BF, BJ, CF, CG, CI, CM, GA, GN, GQ, GW, KM, ML, MR, NE, SN, TD, TG).

(54) Title: WIND TURBINES AND BLADES

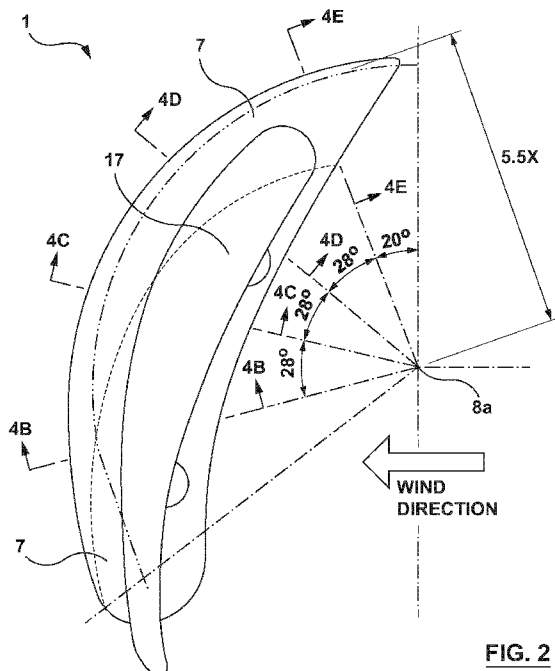

FIG. 2

(57) Abstract: A blade for a turbine, such as a wind turbine, is provided, the blade having: a main blade portion having a wind-facing surface for funneling received wind along an increasingly narrow pathway which exits the blade in an altered direction at an increased velocity; a leading edge portion extending from an upper edge of the wind-facing surface, thereby providing a leading surface which directs additional wind onto the wind-facing surface of the main blade and providing lift; and a trailing edge portion extending from a lower edge of the wind-facing surface, thereby providing a lower barrier for preventing wind escape during progression along the blade.



Published:

- *with international search report (Art. 21(3))*
- *in black and white; the international application as filed contained color or greyscale and is available for download from PATENTSCOPE*

WIND TURBINES AND BLADES

FIELD OF INVENTION

The present invention relates generally to the collection of energy from wind. More specifically, the present invention relates to blades, wind turbines, energy storage, and methods for generating
5 electricity from wind.

BACKGROUND

Alternative and “green” energy sources, particularly those which are non-polluting, are highly desirable. The generation of useful energy from the wind is particularly sought-after, due to the
10 relatively low environmental impact and avoidance of CO₂ emissions. Conventional wind turbines have become commonplace, and are used in many countries around the world to provide green energy to both commercial and residential consumers.

Conventional wind turbines typically employ cantilever beams, or fins, for capturing wind energy. The fins are angled with respect to the wind, and the passing wind imparts a rotational
15 force on the fins which is transmitted to a generator to produce electricity. Unfortunately, conventional wind turbines typically harness only a fraction of the wind energy; can experience damaging stress during high winds if not deactivated; and often require energy consuming and/or costly equipment to maintain proper orientation with respect to changing wind directions.

Efforts have been made in recent years to improve on conventional wind turbine designs. Trillium wind turbines, as described in US Patent Nos. 8,747,067 and 9,464,621 (both of which
20 are herein incorporated by reference in their entireties), represent significant departures from traditional turbine and blade designs, featuring complex blade curvatures for capturing and harnessing energy from wind.

Even with the modern advances made in wind turbine technology, effective wind turbine and
25 blade designs remain highly sought after in the field of green energy. Indeed, alternative, additional, and/or improved blades, wind turbines, and methods for generating electricity from wind are desirable.

SUMMARY OF INVENTION

Described herein are blades, turbines, energy storage systems, and methods for capturing energy. Specially developed turbine blades are described, which feature complex designs for capturing and collecting energy from, in particular, the wind. Turbines, and methods for producing energy
5 from wind, are also provided.

In certain embodiments, turbines and methods described herein may include the use of a weight for storing surplus energy in the form of potential energy by lifting the weight during low energy demand conditions or high wind conditions. Stored surplus captured wind energy may then be released and harnessed by lowering the weight during high energy demand conditions or during
10 low wind conditions, thereby powering energy generation apparatus to generate electricity.

In other embodiments, turbines and methods described herein may include the use of an air compressor to generate a compressed air in a compressed air tank during low energy demand conditions or high wind conditions. Stored surplus captured wind energy may then be released by releasing the compressed air and flowing the compressed air over the blade of the wind
15 turbine to cause rotation thereof during high energy demand conditions or during low wind conditions to power energy generation apparatus to generate electricity.

In an embodiment, there is provided herein a blade for a turbine, such as a wind turbine, the blade comprising:

20 a main blade portion having a first end, a second end, a wind-facing surface, and a rear surface,

the wind-facing surface of the main blade portion being shaped in a concave arc tracing a portion of a substantially circular path of radius r , the substantially circular path decreasing in radius r moving from the first end to the second end along the main blade portion, and

25 the main blade being curved moving from the first end to the second end,

such that incoming wind is received in a first direction at a wind capturing zone located in the vicinity of the first end, is funnelled along the wind-facing surface

toward the second end of the main blade portion along an increasingly narrow pathway defined by the wind-facing surface, and exits the blade in a second direction at an increased velocity;

5 a leading edge portion extending from an upper edge of the wind-facing surface of the main blade portion, the leading edge portion projecting outwardly with respect to the substantially circular path, thereby providing a leading surface which directs additional wind onto the wind-facing surface of the main blade in the vicinity of the wind capturing zone and providing lift; and

10 a trailing edge portion extending from a lower edge of the wind-facing surface of the main blade portion, the trailing edge portion projecting inwardly with respect to the substantially circular path thereby providing a lower barrier for preventing wind escape during progression from the wind capturing zone toward the second end.

In another embodiment of the above blade, the leading edge portion may project outwardly with respect to the substantially circular path at a tangent angle θ which increases moving from the first end to the second end.

20 In still another embodiment of the above blade or blades, the leading edge portion may project outwardly with respect to the substantially circular path with a pitch angle p , which increases moving from the first end to the second end along the main blade portion. In yet another embodiment, the pitch angle p may increase from about 15° at the first end to about 75° at the second end of the main blade portion.

In still another embodiment of the above blade or blades, the trailing edge portion may project inwardly with respect to the substantially circular path at substantially the same angle as the leading edge portion.

25 In yet another embodiment of the above blade or blades, the leading surface of the leading edge portion may be oriented with respect to the trailing edge portion so as to direct wind under the trailing edge toward the first end of the main blade portion, and over the trailing edge portion toward the second end of the main blade portion.

In still another embodiment of the above blade or blades, the radius r of the substantially circular

path may decrease from about $1.75x$ at the first end to about $0.875x$ at the second end of the main blade portion.

In another embodiment of the above blade or blades, the wind-facing surface of the main blade portion may be shaped in a concave arc having a rise on chord b which increases from about $1x$ at the first end to about $1.5x$ proximate the first end, and then decreases to about $0.75x$ at the second end along the main blade portion.

In yet another embodiment of the above blade or blades, the trailing edge portion may increase and then decrease in size moving from the first end to the second end of the main blade portion.

In another embodiment of the above blade or blades, the second direction at which wind exits the blade may be substantially perpendicular to the first direction.

In still another embodiment of the above blade or blades, the second direction at which wind exits the blade may be substantially tangential to the rotation of the blade during use. In yet another embodiment of the above blade or blades, the main blade may be twisted moving from the first end to the second end, such that the second direction at which wind exits the blade is substantially tangential to the rotation of the blade during use. In still another embodiment, the twisting of the main blade may begin toward the second end of the main blade.

In yet another embodiment of the above blade or blades, the portion of the substantially circular path traced by the wind-facing surface of the main blade portion may be defined by a chord angle A , which decreases moving from the first end to the second end along the main blade portion. In another embodiment, the chord angle A may decrease from about 90° at the first end to about 0° at the second end.

In another embodiment of the above blade or blades, the blade may further comprise a jib blade attached to, and spaced apart from, the rear surface of the main blade and extending between the first end and the second end of the main blade, the jib blade substantially following the curve of the main blade, the jib blade directing air along the rear surface of the main blade with relatively low pressure reducing drag and providing lift to aid with rotation of the blade during use. In another embodiment, the jib blade may become increasingly narrow moving from the first end

toward the second end of the main blade. In still another embodiment, the jib blade may be spaced apart from the rear surface of the main blade by a distance y , where y increases moving from the first end to the second end along the main blade portion.

In yet another embodiment of the above blade or blades, the leading edge, trailing edge, and jib
5 blade may have a pitch angle p which is substantially the same.

In still another embodiment, there is provided herein a turbine comprising:

a base;

a nacelle supported by the base, the nacelle comprising a wind-facing end and a rear end
and housing an energy generation assembly; and

10 a plurality of blades attached to the rear end of the nacelle.

In yet another embodiment of the above turbine, the turbine may be for capturing energy from, for example, wind.

In still another embodiment of the above turbine or turbines, the plurality of blades may be blades as defined hereinabove.

15 In yet another embodiment, the above turbine or turbines may comprise 3 blades, or more.

In another embodiment of the above turbine or turbines, the wind-facing end of the nacelle may be aerodynamically-shaped. In certain embodiments, the wind-facing end of the nacelle may be substantially cone-shaped or rounded cone-shaped.

In yet another embodiment of the above turbine or turbines, the nacelle may be rotatable about
20 the base, such that the nacelle and blades act as a vane, maintaining the wind facing-end of the nacelle facing into the wind.

In still another embodiment of the above turbine or turbines, the base thickness may narrow in the vicinity of the nacelle to reduce wind turbulence.

In another embodiment of the above turbine or turbines, the plurality of blades may be adjustably attached to the rear end of the nacelle such that back sweep of the blades can be adjusted to accommodate different wind conditions. In still another embodiment, the back sweep of the blades may be decreased when wind conditions are weak, thereby capturing more wind at the
5 wind capturing zone to assist energy production. In yet another embodiment, the back sweep of the blades may be increased when wind conditions are strong, thereby capturing less wind at the wind capturing zone to prevent damage to the wind turbine.

In still another embodiment of the above turbine or turbines, the turbine may further comprise a supporting member extending from the base to the rear end of the nacelle, and an auxiliary
10 support member extending from each side of the supporting member to each side of the nacelle, the supporting member and two auxiliary support members forming a tripart vane which supports the nacelle and reduces wind turbulence.

In yet another embodiment of the above turbine or turbines, the nacelle may comprise at least one front louvre and at least one back louvre, which may be activated to allow wind to pass
15 through the interior of the nacelle, cooling the energy generation assembly.

In still another embodiment of the above turbine or turbines, the turbine may further comprise:

a weight in communication with the energy generation assembly;

wherein the energy generation assembly is configured to store surplus energy by vertically lifting the weight during low demand or high wind conditions, and

20 wherein the energy generation assembly is configured to recover stored surplus energy by vertically lowering the weight during high demand, or during low wind conditions, and/or to facilitate start-up of the energy generation assembly.

In yet another embodiment, the energy generation assembly may comprise a winch for lifting the weight, and a fly wheel which is rotated by lowering the weight so as to build momentum for
25 overcoming resistance to start-up of the energy generation assembly during low wind conditions and/or to maintain a more constant power output.

In still another embodiment, the base may comprise a vertical support member, and the weight may be housed within and vertically translatable along a length of the vertical support member.

In yet another embodiment, wherein the vertical support member may comprise a subsurface foundation, and the weight may be housed in the subsurface foundation when not being used to
5 store energy.

In another embodiment, the weight may be used as a hoist or service elevator transport to the nacelle and/or blades.

In another embodiment of the above turbine or turbines, wherein the base may be supported by one or more stay cables.

10 In still another embodiment of the above turbine or turbines, the turbine may be for harnessing energy from wind, steam, compressed air, solar, or geothermal driven sources.

In yet another embodiment, there is provided herein a method for generating electricity, said method comprising:

15 capturing wind energy by directing wind across any of the blade or blades defined above to cause rotation thereof; and

using the captured wind energy to power an energy generation assembly to generate electricity.

In another embodiment of the above method, the blade may be a blade of any of the turbine or turbines as defined above.

20 In another embodiment of the above method or methods, the method may further comprise:

storing surplus captured wind energy by vertically lifting a weight during low energy demand conditions or high wind conditions, and

recovering stored surplus captured wind energy by vertically lowering the weight during high energy demand conditions or during low wind conditions to power the energy

generation assembly to generate electricity.

In another embodiment, there is provided herein a method for generating electricity, said method comprising:

5 capturing wind energy by directing wind across a blade of a wind turbine to cause rotation thereof; and

using the captured wind energy to power an energy generation assembly to generate electricity;

wherein the method further comprises:

10 storing surplus captured wind energy by vertically lifting a weight during low energy demand conditions or high wind conditions; and

recovering stored surplus captured wind energy by vertically lowering the weight during high energy demand conditions or during low wind conditions to power the energy generation assembly to generate electricity.

15 In another embodiment, there is provided herein a method for generating electricity, said method comprising:

capturing wind energy by directing wind across a blade of a wind turbine to cause rotation thereof; and

using the captured wind energy to power an energy generation assembly to generate electricity;

20 wherein the method further comprises:

storing surplus captured wind energy by powering an air compressor to generate a compressed air in a compressed air tank during low energy demand conditions or high wind conditions; and

recovering stored surplus captured wind energy by releasing the compressed air to a pneumatic drive transferring the energy to a flywheel and/or to the rotor/blades to cause rotation thereof during high energy demand conditions or during low wind conditions to power the energy generation assembly to generate electricity.

5 In another embodiment of the above method, the method may further comprise:

cooling the compressed air during the step of storing, thereby increasing energy storage by removing heat generated by compression;

heating the compressed air during the step of recovering, thereby increasing the amount of energy received by the blade of the wind turbine;

10 or both.

In yet another embodiment of the above method or methods, the step of cooling may comprise cooling the compressed air using, directly or indirectly, a heat exchange fluid from a tank or reservoir, thereby cooling the compressed air and heating the heat exchange fluid of the tank or reservoir during the step of storing.

15 In still another embodiment of the above method or methods, the step of heating may comprise heating the compressed air using, directly or indirectly, a heat exchange fluid from a tank or reservoir, thereby heating the compressed air and cooling the heat exchange fluid of the tank or reservoir during the step of recovering.

In yet another embodiment, the tank or reservoir may comprise a geothermal reservoir.

20 In still another embodiment of the method or methods above, the method may comprise repeating the steps of storing and recovering as conditions cycle between low energy demand conditions or high wind conditions and high energy demand conditions or during low wind conditions.

In yet another embodiment, there is provided herein a method for storing surplus energy captured
25 by a wind turbine, the method comprising:

storing the surplus energy by vertically lifting a weight during low energy demand conditions or high wind conditions, and

5 recovering the stored surplus energy by vertically lowering the weight during high energy demand conditions or during low wind conditions to power an energy generation assembly to generate electricity.

In yet another embodiment, there is provided herein a method for storing surplus energy captured by a wind turbine, the method comprising:

storing the surplus energy by powering an air compressor to generate a compressed air in a compressed air tank during low energy demand conditions or high wind conditions; and

10 recovering the stored surplus energy by releasing the compressed air to a pneumatic drive transferring the energy to a flywheel and/or to the rotor/blades to cause rotation thereof during high energy demand conditions or during low wind conditions to power an energy generation assembly to generate electricity.

15 In yet another embodiment, the air compressor may be powered, in part or in full, by energy generated by the wind turbine.

In still another embodiment of the method or methods above, the method may further comprise:

cooling the compressed air during the step of storing, thereby increasing energy storage by removing heat generated by compression;

20 heating the compressed air during the step of recovering, thereby increasing the amount of energy received by the blade or blades of the wind turbine;

or both.

In another embodiment of the method or methods above, the step of cooling may comprise cooling the compressed air using, directly or indirectly, a heat exchange fluid from a tank or reservoir, thereby cooling the compressed air and heating the heat exchange fluid of the tank or
25 reservoir during the step of storing.

In yet another embodiment of the method or methods above, the step of heating may comprise heating the compressed air using, directly or indirectly, a heat exchange fluid from a tank or reservoir, thereby heating the compressed air and cooling the heat exchange fluid of the tank or reservoir during the step of recovering.

- 5 In still another embodiment of the method or methods above, the tank or reservoir may comprise a geothermal reservoir.

In yet another embodiment of the method or methods above, the method may comprise repeating the steps of storing and recovering as conditions cycle between low energy demand conditions or high wind conditions and high energy demand conditions or during low wind conditions.

- 10 In another embodiment, there is provide herein a compressed air-based energy storage system, the system comprising:

a compressed air tank;

an air compressor configured to compress air from an air inlet into the compressed air tank; and

- 15 an outlet from the compressed air tank, the outlet configured to direct compressed air from the compressed air tank to an electricity generation apparatus for generating electricity from the compressed air.

In another embodiment, the air compressor may be powered, at least in part, by the electricity generation apparatus.

- 20 In yet another embodiment of the compressed air-based energy storage system or systems above, the electricity generation apparatus may comprise a wind turbine.

- In still another embodiment of the system or systems above, the system may further comprise a heat exchange system configured to cool the compressed air while compressed air is being stored in the compressed air tank, configured to heat the compressed air while compressed air is being
25 directed through the outlet to the electricity generation apparatus, or both.

In yet another embodiment of the compressed air-based energy storage system or systems above, the heat exchange system may comprise a tank or reservoir for a heat exchange fluid, the tank or reservoir configured to circulate the heat exchange fluid such that the heat exchange fluid provides, directly or indirectly, cooling to the compressed air while compressed air is being
5 stored in the compressed air tank, and becomes heated; heating to the compressed air while compressed air is being directed through the outlet to the electricity generation apparatus, and becomes cooled; or both.

In yet another embodiment of the compressed air-based energy storage system or systems above, the tank or reservoir may comprise a geothermal reservoir.

10 In another embodiment, there is provided herein a wind turbine comprising:

a base;

a nacelle supported by the base;

a plurality of blades attached to the nacelle; and

a compressed air-based energy storage system as described herein.

15 In yet another embodiment of the wind turbine above, the blades may be blades as described herein.

BRIEF DESCRIPTION OF DRAWINGS

20 These, and other features, aspects, and advantages of the present invention will become better understood with regard to the following description and accompanying drawings, wherein:

FIGURE 1 shows a perspective view of an embodiment of a blade for a wind turbine as described herein, when viewed toward the first end of the blade;

FIGURE 2 shows another perspective view of the blade for a wind turbine shown in Figure 1,

when viewed toward the side of the main blade portion and the jib blade, as viewed at about 90° to the direction of the wind;

FIGURE 3 shows a front perspective view of the blade for a wind turbine shown in Figure 1, when viewed toward the wind facing surface of the blade;

5 FIGURE 4 shows a cross sectional view of the blade for a wind turbine as shown in Figure 1;

FIGURE 5 shows 5 cross sectional views (Figures 5A-5E) of the blade for a wind turbine as shown in Figure 1, the cross sectional views depicting cross-sections 4A-4E as indicated in Figures 2 and 3, which progress from the second end (Figure 5A) to the first end (Figure 5E) along the main blade portion;

10 FIGURE 6 shows a rear perspective view (6A) and a cross-sectional side view (6B) of an embodiment of a wind turbine as described herein;

FIGURE 7 shows a perspective view of the wind turbine shown in Figure 6, with the nacelle and base made transparent to illustrate internal elements;

FIGURE 8 shows side profile (8A) and top (8B) views of the wind turbine shown in Figure 6;

15 FIGURE 9 shows 5 cross sectional views (Figures 9A-9E) of another embodiment of a blade for a wind turbine. The cross sectional views depict a variation closely related to those in Figure 5, but adjusted to depict a blade embodiment with reduced twist toward the second end of the blade (compare Figure 5B with Figure 9B);

20 FIGURE 10 shows (A) a wind turbine which includes an embodiment of a compressed air-based energy storage unit as described herein, and (B) a cross-section taken along A-A in (A); and

FIGURES 11(A) and 11(B) show embodiments of compressed air-based energy storage units as described herein which may be retrofitted to existing wind turbines, or which may be included as part of new-build wind turbines.

DETAILED DESCRIPTION

Described herein are blades, turbines, energy storage systems, and methods for capturing energy. It will be appreciated that embodiments and examples are provided for illustrative purposes intended for those skilled in the art, and are not meant to be limiting in any way.

5 *Wind Turbine Blades*

In an embodiment, there are provided herein blades for a wind turbine. Such blades may feature a main blade portion, a leading edge portion, and a trailing edge portion designed for capturing wind and collecting energy therefrom. An exemplary and illustrative embodiment of such blades is depicted in Figures 1-5. As will be understood, these Figures are intended for the person of skill in the art, and are not intended to be limiting in any way. The skilled person having regard to the teachings herein will understand that several suitable modifications, additions, deletions, substitutions, and alterations may be made to the blades depicted in Figures 1-5 without departing from the scope of the present disclosure. Several design parameters and values are provided in Figures 1-5, however the skilled person will recognize that many suitable variations may be made to suit particular applications as desired.

Figures 1-5 depict an embodiment of a blade (1) for a wind turbine (2) as described herein, the blade (1) comprising:

a main blade portion (3) having a first end (4), a second end (5), a wind-facing surface (6), and a rear surface (7),

20 the wind-facing surface (6) of the main blade portion (3) being shaped in a concave arc tracing a portion of a substantially circular path (8) of radius r , the substantially circular path (8) decreasing in radius r moving from the first end (4) to the second end (5) along the main blade portion (3), and

25 the main blade portion (3) being curved moving from the first end (4) to the second end (5),

such that incoming wind is received in a first direction at a wind capturing zone (9) located in the vicinity of the first end (4), is funnelled along the wind-facing

surface (6) toward the second end (5) of the main blade portion (3) along an increasingly narrow pathway (10) defined by the wind-facing surface (6), and exits the blade (1) in a second direction at an increased velocity;

5 a leading edge portion (11) extending from an upper edge (12) of the wind-facing surface (6) of the main blade portion (3), the leading edge portion (11) projecting outwardly with respect to the substantially circular path (8), thereby providing a leading surface (13) which directs additional wind onto the wind-facing surface (6) of the main blade portion (3) in the vicinity of the wind capturing zone (9) and provides lift; and

10 a trailing edge portion (14) extending from a lower edge (15) of the wind-facing surface (6) of the main blade portion (3), the trailing edge portion (14) projecting inwardly with respect to the substantially circular path (8) thereby providing a lower barrier (16) for preventing wind escape during progression from the wind capturing zone (9) toward the second end (5).

15 In the depicted embodiment, the leading surface (13) of the leading edge portion (11) is oriented with respect to the trailing edge portion (14) so as to direct wind under the trailing edge (14) toward the first end (4) of the main blade portion (3), and over the trailing edge portion (14) toward the second end (5) of the main blade portion (3).

20 As well, in the depicted embodiment, the leading edge portion (11) projects outwardly with respect to the substantially circular path at a tangent angle θ which increases moving from the first end (4) to the second end (5). Tangent angle θ is labelled in Figure 9C. In the depicted embodiment, the angle at which the leading edge portion (11) projects may also be considered with respect to pitch angle p , which is measured from the horizontal or wind direction (see Figure 5). In certain embodiments, the pitch angle p may increase moving from the first end to the second end along the main blade portion. By way of example, the pitch angle p may increase
25 from about 15° at the first end to about 75° at the second end of the main blade portion. It will be understood that pitch angle may also be referred to as angle of attack.

In the depicted embodiment, the trailing edge portion projects inwardly with respect to the substantially circular path at substantially the same angle as the leading edge portion. As shown

in Figures 5 and 9, in certain embodiments the pitch angle p of the leading edge and the trailing edge may be the same or substantially the same along at least a portion of the blade.

As will be understood, blades as described herein may feature a main blade portion (3) featuring a wind-facing surface (6), and may provide a wind capturing zone (9) which captures incoming wind received in a first direction, and an increasing narrow pathway (10) along which the captured wind is funnelled until wind exits the blade in a second direction at an increased velocity (due to narrowing of the pathway, wind is accelerated). Figure 2 depicts incoming wind direction, and twisting/curvature of the illustrated blade which gradually redirects wind such that wind exits in a second direction which is different from the first. As wind is redirected, it pushes on the blade, imparting rotational force. Figure 3 provides a front perspective view of an embodiment of a blade for a wind turbine, illustrating the wind facing surface and the twisting/curving of the main blade portion moving from the first end to the second end.

In the embodiment depicted in Figures 1-3, the second direction at which wind exits the blade is substantially perpendicular (i.e. about 90°) to the first direction of the incoming wind. In other words, in the illustrated embodiment, incoming wind is received in a first direction which is substantially parallel to the ground, and exits the blade in a second direction which at an angle of about 90° to the first direction. In the depicted embodiment, the curvature of the blade (1) is such that the second direction of the exiting wind is not only about 90° to the first direction of the incoming wind, but is also substantially tangential to the rotation of the blade during use. As will be understood, the depicted blade may be attached to a hub of a wind turbine, and caused to rotate about the hub by force from the incoming wind. The second end (5) of the blade will thus trace a circular path when rotating about the hub. In the depicted embodiment, the curvature of the blade (1) is such that the second direction of the exiting wind is substantially tangential to this circular path, with wind exiting behind the blade which is in rotation, further adding to the energy being collected from the incoming wind by adding force contributing to blade rotation and/or directing wind behind the rotating blade.

The twisting main blade may be considered with regard to Figures 3 and 5. As shown in the depicted embodiment, the main blade may be twisted moving from the first end to the second end, such that the second direction at which wind exits the blade is substantially tangential to the

rotation of the blade during using. In Figures 3 and 5, the twisting of the main blade occurs toward the second end of the main blade, at or around cross-section 4B. Figure 5 depicts cross sections of a blade embodiment having a pronounced twist (see Figure 5B), whereas Figure 9 depicts a blade variation without substantial twisting (see Figure 9B, compared with Figure 5B).

5 As such, in certain embodiments, the curve of the main blade may therefor result in wind exiting the main blade about 90° to the incoming wind direction, while the twist of the main blade (if present) may result in wind exiting the main blade substantially tangential to the rotation of the blade during use.

As will be understood, the main blade portion (3) may present a wind-facing surface (6) being
10 shaped in a concave arc tracing a portion of a substantially circular path (8) of radius r , the substantially circular path (8) decreasing in radius r moving from the first end (4) to the second end (5) along the main blade portion (3). Figures 4 and 5 provide a cross sectional views of a wind turbine blade embodiment as described herein, which further illustrates design features of the blade and wind facing surface. Figure 5, in particular, shows 5 illustrative cross sectional
15 views (Figures 5A-5E) of an embodiment of a blade for a wind turbine, the cross sectional views depicting cross-sections 4A-4E as labelled in Figures 2 and 3, which progress from the second end (Figure 5A) to the first end (Figure 5E) along the main blade portion. The depicted wind-facing surface (6) is shaped in a concave arc tracing a portion of a substantially circular path (8) of radius R . As depicted moving from figures 5E to 5A, the substantially circular path (8)
20 decreases in radius R moving from the first end (4) to the second end (5) along the main blade portion (3). In the depicted embodiment, the radius R of the substantially circular path (8) decreases from about $1.75x$ near the first end (4) to about $0.875x$ near the second end (5) of the main blade portion (3). In the blade embodiment depicted in Figures 4 and 5, the wind-facing surface (6) of the main blade portion (3) is shaped in a concave arc having a rise on chord b
25 which increases from about $1x$ at the first end to about $1.5x$ proximate the first end, and then decreases to about $0.75x$ at the second end along the main blade portion.

In the blade depicted in Figures 1-5, the portion of the substantially circular path traced by the wind-facing surface (6) of the main blade portion (3) is defined by a chord angle A (see Figures 4 and 5A-5E), which decreases moving from the first end (4) to the second end (5) along the main

blade portion (3). By way of example, in the depicted blade, the chord angle A decreases from about 90° at the first end to about 0° at the second end.

As will be understood, these exemplary values convey relative dimensions, and are not tied to a particular size or scale value.

5 In the blade embodiment depicted in Figures 1-5 and 9, the blade comprises a leading edge portion (11) extending from an upper edge (12) of the wind-facing surface (5) of the main blade portion (3), the leading edge portion (11) projecting outwardly with respect to the substantially circular path (8) at a tangent angle θ which increases moving from the first end (4) to the second end (5), thereby providing a leading surface (13) which directs additional wind onto the wind-
10 facing surface (6) of the main blade portion (3) in the vicinity of the wind capturing zone (9) and provides lift. Tangent angle θ is labelled in Figure 9C. In the depicted embodiments, the angle at which the leading edge portion (11) projects may also be considered with respect to pitch angle p , which is measured from the horizontal or wind direction (see Figure 5). In certain embodiments, the pitch angle p may increase moving from the first end to the second end along
15 the main blade portion. By way of example, the pitch angle p may increase from about 15° at the first end to about 75° at the second end of the main blade portion. It will be understood that pitch angle may also be referred to as angle of attack.

In the depicted embodiments, the trailing edge portion projects inwardly with respect to the substantially circular path at substantially the same angle as the leading edge portion. As shown
20 in Figures 5 and 9, in certain embodiments the pitch angle p of the leading edge and the trailing edge may be the same, or substantially the same, along at least a portion of the blade.

The outward projection of the leading edge portion (11) may be seen in Figures 4, 5, and 9, illustrating projection of the leading edge portion (11) outwardly from the circular path (8). The tangential angle θ defining the direction of projection is shown in Figure 9C, and is taken as the
25 angle between the leading surface (13) and the tangent to the circular path (8) taken at the point of the leading edge about the circular path.

In certain embodiments, the leading edge portion (11) may project outwardly with respect to the substantially circular path (8) with a pitch angle p , which increases moving from the first end (4)

to the second end (5) along the main blade portion (3). In the blade embodiments depicted in Figures 4, 5, and 9, the pitch angle p increases from about 15° at the first end to about 75° at the second end of the main blade portion (3).

In the blade embodiment depicted in Figures 1-5, the blade comprises a trailing edge portion (14) extending from a lower edge (15) of the wind-facing surface (6) of the main blade portion (3), the trailing edge portion (14) projecting inwardly with respect to the substantially circular path (8) thereby providing a lower barrier (16) for preventing wind escape during progression from the wind capturing zone (9) toward the second end (5). The inward projection of the trailing edge portion (14) may be seen in Figures 4 and 5, illustrating projection of the trailing edge portion (14) inwardly from the circular path (8). In certain embodiments, the pitch angle p of the leading edge and the trailing edge may be the same, or substantially the same, along at least a portion of the blade (see Figures 5, 9). As can be seen in Figure 3, in the depicted blade embodiment the trailing edge portion (14) first increases, and then decreases, in size/height moving from the vicinity of the first end (4) to the second end (5) of the main blade portion (3).

The trailing edge portion (14) has the effect of providing a lower barrier (16), or ridge, which prevents escape of wind as it travels along the increasingly narrow pathway (10) during use.

The blade embodiment depicted in Figures 1-5 additionally includes a jib blade (17) attached to, and spaced apart from, the rear surface (7) of the main blade (3) and extending along a region located between the first end (4) and the second end (5) of the main blade (3). In the depicted embodiment, the jib blade (17) substantially follows the twist/curve of the main blade (3) and becomes increasingly narrow moving from the first end toward the second end of the main blade. In the depicted embodiments, the jib blade (17) functions to direct air along the rear surface (7) of the main blade (with passing wind barely skimming over the rear surface) with relatively low pressure reducing drag and provide lift to aid with rotation of the blade (3) during use.

As shown in Figure 4, in certain embodiments the jib blade may also be positioned at a pitch angle p , which is measured from the horizontal or wind direction (see Figure 4). In certain embodiments, the pitch angle p may be at substantially the same angle as the leading edge portion, the trailing edge portion, or both. As shown in Figure 4, in certain embodiments, the

pitch angle p of the leading edge, the trailing edge, and the jib blade may be the same or substantially the same along at least a portion of the overall blade.

In certain embodiments, the jib blade (17) may be spaced apart from the rear surface (7) of the main blade (3) by a distance y (see Figure 4), where y increases moving from the first end (4) to the second end (5) along the main blade portion (3). Spacing y may be adjusted such that wind
5 skims the back surface of the main blade in certain embodiments.

In certain embodiments, the blade may include, on its rear surface (7), a reinforced attachment point for hinged connection with a nacelle of a wind turbine. By way of example, a pair of blade extensions may project from the rear surface of the main blade near the first end, with a hinged
10 joint located therebetween for connecting with the rotor of a wind turbine (see Figure 6).

As will be understood, Figures 1, 2, 4, 5, and 9 depict direction of incoming wind. However, since the blades will be in motion during use, it will be understood that rotating blades may experience an apparent direction of wind which is depicted in Figure 4 for illustrative purposes.

Wind Turbines

15 In another embodiment, there are provided herein wind turbines for generating energy from wind. Such wind turbines may, in certain embodiments, feature blade(s) as describe hereinabove, although it will be understood that wind turbines as described herein are not limited to the above-described blades and may comprise any other suitable blade(s) appropriate for the particular application. In certain embodiments, wind turbines may include, for example, blade(s) as
20 described hereinabove, blade(s) as described in either of US Patent Nos. 8,747,067 and/or 9,464,621 (both of which are herein incorporated by reference in their entireties), or other suitable blade(s) known to the person of skill in the art. Although the wind turbines described below are primarily discussed as featuring blades as described hereinabove and depicted in Figures 1-5 and 9, it will be understood that other blade configurations are also contemplated
25 herein.

Exemplary and illustrative embodiments of wind turbines are described herein are depicted in Figures 6-8. As will be understood, these Figures are intended for the person of skill in the art, and are not intended to be limiting in any way. The skilled person having regard to the teachings

herein will understand that several suitable modifications, additions, deletions, substitutions, and alterations may be made to the wind turbines depicted in Figures 6-8 without departing from the scope of the present disclosure. Several design features are provided in Figures 6-8, however the skilled person will recognize that many suitable variations may be made to suitable particular applications as desired.

Figures 6-8 depict embodiments of a wind turbine (2) as described herein, the wind turbine (2) comprising:

a base (18);

a nacelle (19) supported by the base (18), the nacelle (19) comprising a wind-facing end (20) and a rear end (21) and housing an energy generation assembly (22); and

a plurality of blades (1) (such as those depicted in Figures 1-5 and 9) attached to the rear end (21) of the nacelle (19).

In Figures 6-8, the wind turbines comprise 3 blades (1), although it will be understood that other configurations may be possible. For example, the wind turbine (2) may comprise any suitable number of blades appropriate for the particular application.

Wind turbines (2) as described herein may feature a base (18). In the embodiments depicted in Figures 6-8, the base (18) is a tower-type base comprising a vertical support member (30). As shown in Figures 8A and 8B, the vertical support member (30) comprises a subsurface foundation (31), and the base (18) is additionally supported by one or more stay cables (32) attached thereto and anchored to the ground by helical piles (47).

In certain embodiments, as depicted in Figure 7, the wind turbine (2) may comprise a supporting member (23) extending from the base (18) to the rear end (21) of the nacelle (19). In certain further embodiments, the base (18) may additionally include auxiliary support members (24) extending from each side of the supporting member (23) to each side of the nacelle (19), the supporting member (23) and two auxiliary support members (24) forming a tripart vane which supports the nacelle (19) and reduces wind turbulence.

In certain embodiments, the base thickness may narrow in the vicinity of the nacelle so as to reduce wind turbulence.

As will be understood, a variety of other suitable base configurations and structures may be possible. Suitable bases are not limited to those depicted in Figures 7 and 8.

- 5 The wind turbines (2) depicted in Figures 6-8 comprise a nacelle (19) supported by the base (18), the nacelle (19) comprising a wind-facing end (20) and a rear end (21) and housing an energy generation assembly (22). In the embodiments depicted in Figures 6-8, the wind-facing end (20) of the nacelle (19) is aerodynamically-shaped, adopting a substantially cone-shaped or rounded cone-shaped configuration to guide incoming wind around the nacelle and toward the blades.
- 10 In the depicted wind turbine embodiments, the nacelle (19) is rotatable about the base (18), such that the nacelle (19) and blades (2) act as a vane, maintaining the wind facing-end (20) of the nacelle (19) facing into the wind. In the illustrated embodiments, the nacelle (19) is rotatable about the base (18) by way of a bushing/bearing mechanism, or another suitable turn-table type mechanism, allowing nacelle rotation without rotation of the base. In certain embodiments, the
- 15 use of conventional yaw mechanism may thus be avoided. The skilled person will understand that other rotational mechanisms may be used to achieve such function of the nacelle.

In the depicted wind turbine embodiments, the nacelle (19) comprises at least one front louvre (25) and at least one back louvre (26), which may be activated to allow wind to pass through the interior of the nacelle (19), cooling the energy generation assembly (22) as needed.

- 20 In the illustrated wind turbines (2), the blades (1) are connected to the rear end (21) of the nacelle (19) via a rotor/hub (33). By positioning the blades (1) at the rear of the nacelle (19), turbulence about the turbine may be reduced and/or the vane effect of the wind turbine may be emphasized in certain embodiments.

- In certain embodiments, as depicted in Figures 6A and 6B, the plurality of blades (1) are
- 25 adjustably attached to the rear end (21) of the nacelle (19) such that back sweep of the blades (1) may be adjusted to accommodate different wind conditions. By way of example, as shown in Figures 6A and 6B, hydraulics (34) may be configured to adjust back sweep angle of the blades

during use. Individual hydraulics (34) may be used to control each blade, or a combined hydraulics (34) system may be used to operate multiple blades simultaneously using, for example, an umbrella-type hydraulic configuration. In certain embodiments, back sweep adjustment may be used to decrease rotor diameter (increasing rpm) so as to maintain substantial
5 the same power output.

In certain embodiments, back sweep of the blades may be adjustable such that the back sweep can be decreased when wind conditions are weak, thereby capturing more wind at the wind capturing zone to assist energy production. Further, in certain embodiments, the back sweep of the blades may be increased when wind conditions are strong, thereby capturing less wind at the
10 wind capturing zone and decreasing rotor diameter to prevent damage to the wind turbine, as needed.

As will be understood, the energy generation apparatus of the wind turbines as described herein may include any suitable energy generation apparatus known to the person of skill in the art which may be configured to receive force/energy from the rotating turbine blades and convert the
15 received force/energy into useful form of energy such as electricity (and/or potential or stored energy, depending on application).

In certain embodiments, suitable energy generation apparatus may comprise a generator in communication with the wind turbine blades via, for example, a drive shaft, the generator receiving rotational energy from the wind turbines and producing electricity. Such generators
20 may be housed within: the nacelle; in the base of the wind turbine; or may be located at ground level, depending on the particular application.

In certain embodiments, wind turbines (2) as described herein may further comprise:

a weight (27) in communication with the energy generation assembly (22);

wherein the energy generation assembly (22) is configured to store surplus energy by lifting the
25 weight (27) during low demand or high wind conditions, and

wherein the energy generation assembly (22) is configured to recover stored surplus energy by

lowering the weight (27) during high demand, or during low wind conditions to facilitate start-up of the energy generation assembly (22).

In certain embodiments, the weight (27) may be formed from a dense material such as, for example, iron ingot or one or more stacked metal slabs. As will be understood, the weight (27) functions to store potential energy. As such, it is also contemplated herein that other suitable potential energy storage mechanisms may be used including, by way of example, a spring or elastic potential energy storage member.

In certain embodiments, the energy generation assembly (22) may comprise a start-up generator (40) and a cut-in generator (41), whereby the start-up generator, assisted by energy from lowering the weight (27), may be used to generate energy during low-wind conditions. Once a suitable momentum is reached following start-up, a relay switch (43) may be used to activate the cut-in generator (41) for further energy production. In certain embodiments, the energy generation assembly (22) may comprise a winch (28) for lifting the weight (27), and a fly wheel (29) which is rotated by lowering the weight (27) so as to build momentum for overcoming resistance to start-up of the energy generation assembly during low wind conditions.

In certain further embodiments, the base (18) of the wind turbine (2) may comprise a vertical support member (30), and the weight (27) may be housed within and vertically translatable along a length of the vertical support member (30). Such an embodiment is depicted in Figures 7-8. In the depicted embodiment, the vertical support member (30) comprises a subsurface foundation (31), and the weight (27) is housed in the subsurface foundation (31) when not being used to store energy and/or when being used as an elevator or dumbwaiter. Additionally, in the depicted embodiment, the weight (27) may be used as a hoist or service elevator transport from ground level to the nacelle (19) and/or blades (1).

In still other embodiments, the base (12) of the wind turbine (2) may comprise an energy storage unit for storing energy during low demand, and providing the stored energy during high demand. In certain embodiments, the energy storage unit may comprise a weight which may be lifted to store energy and lowered to release stored energy, as described above. In certain other embodiments, the energy storage unit may comprise a compressed air-based energy storage unit

comprising a high-pressure air compressor powered by the wind turbine, which may be used to compress air from the environment into a compressed air tank during periods of low demand, or where energy being generated by the wind turbine is otherwise in excess of what is needed. During periods of high demand or low wind, or another such period in which extra energy supply is desired, the compressed air may be released from the tank and blown over the blades of the wind turbine to cause rotation thereof to generate additional energy.

Compression of air generates heat, which may limit the amount of air which can be compressed and stored during periods of low demand. During periods of high demand, however, heating of the compressed air may provide more energy for capture by the wind turbine blades. Accordingly, in certain embodiments, a heat exchange unit may be provided for cooling the compressed air during storage, for heating the compressed air during release of the compressed air to the blades, or for both. By way of example, in certain embodiments, a geothermal-based heat exchange unit may be provided, although it is contemplated that any other suitable heat exchange unit may alternatively or additionally be provided.

In certain embodiments, a heat exchange unit may comprise an underground (or partially underground) geothermal reservoir, with one or more refrigerant circuits for flowing refrigerant (for example, water, or other suitable refrigerant, coolant, or heat exchange fluid) out of, and back into, the geothermal reservoir. The one or more refrigerant circuits may be configured to directly exchange thermal energy with the compressed air tank, or may be configured for thermal energy exchange with a separate refrigerant circuit (via, for example, a heat exchanger) which is in turn configured for thermal energy exchange with the compressed air tank, for example.

During periods of low demand, it is contemplated that such embodiments may enter a “cooling cycle”, during which air is compressed into the compressed air tank, and the compressed air is cooled using cool water (or other thermal energy exchange fluid) from the geothermal reservoir, thereby allowing for increased energy storage. In the process of cooling the compressed air, the water (or other thermal energy exchange fluid) of the geothermal reservoir will become heated, either by taking heat directly from the compressed air, or by taking heat from a second refrigerant circuit which in turn takes heat from the compressed air tank.

During periods of high demand or low wind, it is then contemplated that a pneumatic drive may be provided which uses the compressed air from the compressed air tank to add energy to the flywheel and/or rotor/blades that is above and beyond the energy produced by the normal wind speed. A “heating cycle” may be entered, during which hot water from the geothermal reservoir
5 may be used to heat the compressed air, either directly or by heating a second refrigerant circuit which in turn heats the compressed air. Heating of the compressed air may increase the amount of energy provided by the compressed air to the flywheel, and to the blades of the wind turbine.

During the heating cycle, heating of the compressed air may have the effect of cooling the water (or other thermal energy exchange fluid) of the geothermal reservoir, preparing the system for
10 another cooling cycle, thereby providing a repeatable loop.

As will be understood, various configurations of the compressed air-based energy storage unit described herein may be provided. By way of non-limiting example, in certain embodiments, the compressed air-based energy storage unit may comprise an air compressor powered, directly or indirectly, by the wind turbine, or another source such as a solar energy source or a natural gas
15 source; a compressed air tank in communication with the air compressor for receiving and storing compressed air therefrom; an optional stand-by air compressor, such as a natural gas-powered air compressor, for supplying compressed air to the compressed air tank when conditions are not suitable for operation of the main air compressor; a refrigerant circuit configured for thermal energy exchange with the compressed air tank; a geothermal reservoir
20 containing a coolant or heat exchange fluid (for example, water or an aqueous fluid); a refrigerant circuit configured for thermal energy exchange with the fluid reservoir (for example, by cycling the coolant or heat exchange fluid out of, and back into, the geothermal reservoir); and a heat exchanger configured for exchanging thermal energy between the coolants/fluids of the two refrigerant circuits.

25 In certain other embodiments, the compressed air-based energy storage unit may comprise an air compressor powered, directly or indirectly, by the wind turbine, or another source such as a solar energy source or a natural gas source; a compressed air tank in communication with the air compressor for receiving and storing compressed air therefrom; an optional stand-by air compressor, such as a natural gas-powered air compressor, for supplying compressed air to the

compressed air tank when conditions are not suitable for operation of the main air compressor; a refrigerant circuit configured for thermal energy exchange with the compressed air tank; and a heat exchanger configured for exchanging thermal energy between the coolant/fluid of the refrigerant circuit and air. In other words, in certain embodiments, the geothermal reservoir may
5 be omitted, and the compressed air may be heated/cooled using thermal energy exchange with air. In certain embodiments, the heat exchanger may comprise any suitable cooling, heating, or dual-function thermal energy exchanger known to the person of skill in the art having regard to the teachings herein.

In still other embodiments, the compressed air-based energy storage unit may comprise an air
10 compressor powered, directly or indirectly, by the wind turbine, or another source such as a solar energy source or a natural gas source; a compressed air tank in communication with the air compressor for receiving and storing compressed air therefrom; and an optional stand-by air compressor, such as a natural gas-powered air compressor, for supplying compressed air to the compressed air tank when conditions are not suitable for operation of the main air compressor. In
15 other words, in certain embodiments, the apparatus for heating/cooling of the compressed air may be omitted, and the compressed air-based energy storage unit may function by storing and releasing compressed air.

As will be understood, in certain embodiments, compressed air-based energy storage units as described herein may be used with newly constructed wind turbines, or may be retrofitted onto
20 existing wind turbines. In certain embodiments, the wind turbines may comprise a wind turbine as described herein, although it will be understood that compressed air-based energy storage units as described herein may be used in connection with generally any suitable wind turbine known in the art. In certain embodiments, the compressed air-based energy storage units may be integrated with one or more wind turbine(s), or may be configured as separate unit(s) in
25 communication with the one or more wind turbine(s).

In certain embodiments, the components of the compressed air-based energy storage unit may be integrated into the foundation, base, and/or nacelle of the wind turbine. For example, the compressed air tank, compressor(s), and heat exchanger may be integrated into the base of the wind turbine and the geothermal reservoir may be integrated into, or may function as, the

foundation of the wind turbine. Alternatively, the compressed air tank, compressor(s), heat exchanger, and/or the geothermal reservoir, or any combination thereof, may be provided separately from the wind turbine and in communication therewith. In certain embodiments, for example, the geothermal reservoir may be integrated with the foundation of the wind turbine, and
5 the air compressor(s), compressed air tank, and heat exchanger may be provided separately from the wind turbine but in communication with the wind turbine and the geothermal reservoir.

Figure 10 depicts an embodiment of a wind turbine (2) as described herein, which includes an example of a compressed air-based energy storage unit as described herein. In the depicted embodiment, the compressed air-based energy storage unit of the wind turbine (2) comprises a
10 high pressure air compressor (54) which draws air in via an air intake and compresses the air into compressed air tank (53). The high pressure air compressor (54) is powered by energy generated from the wind turbine (2). The compressed air-based energy storage unit further includes a stand-by air compressor (55) which in this example runs on natural gas, for supplying compressed air when conditions are not suitable for operation of the high pressure air compressor (54), or to
15 supplement air compressor (54). The stand-by air compressor (55) is optional, and may be omitted. During periods of low demand and/or high wind, the system is configured to store excess energy as compressed air in the compressed air tank (53). During periods of high demand and/or low wind, the system is configured to release air from the compressed air tank (53) and direct the released air to the pneumatic drive (58) transferring the energy to a flywheel and/or
20 the rotor/blades over the blades of the wind turbine (2) to generate power, the compressed air being released via high pressure air supply (56), which is in communication with a swivel connection (57) and supplies the released air to pneumatic drive (58) which supplies energy to the flywheel (60), and the air discharged by the pneumatic drive (58) is directed to the rotor/blades to cause rotation thereof. In the depicted embodiment, the wind turbine (2) includes
25 a brake (59), a fly wheel (60) which is rotated by the blades, a low-speed shaft (61) rotated by the flywheel, a gear box (62) coupling low speed shaft (61) with high speed shaft (63), and start-up and cut-in generators (64) and (65) powered by the high speed shaft (63).

In Figure 10, the compressed air-based energy storage unit further comprises a refrigerant circuit (51) configured for thermal energy exchange with the compressed air tank (53) to provide

heating/cooling of the compressed air. The refrigerant circuit includes a cold refrigerant supply (51a) and a hot refrigerant return (51c) which operates during low demand, and which then functions as a cold refrigerant return (51b) and a hot refrigerant supply (51d) during high demand. The refrigerant circuit (51) is in communication with a heat exchanger (52).

- 5 The depicted embodiment of Figure 10 further includes a geothermal reservoir (49), and a refrigerant circuit (50) configured for circulating a fluid (i.e. water or another thermal exchange fluid) in the reservoir to the heat exchanger (52), and back. In certain embodiments, the refrigerant circuit (50) may directly circulate fluid from the geothermal reservoir (49) as depicted, however it is also contemplated that the refrigerant circuit (50) may contain its own
- 10 heat exchange fluid, and the refrigerant circuit may be configured for thermal energy exchange with the fluid in the geothermal reservoir (49), for example. The depicted refrigerator circuit (50) includes a cold water supply (50a) and a hot water return (50c) which operates during low demand, and which then functions as a cold water return (50b) and a hot water supply (50d) during high demand. The refrigerant circuit (50) is in communication with a heat exchanger (52).
- 15 At the heat exchanger (52), thermal energy exchange occurs between the refrigerant circuits (51) and (52) in accordance with the current mode of operation.

In the embodiment depicted in Figure 10, the components of the compressed air-based energy storage unit are integrated with the wind turbine (2), with most of the components positioned in the base (12) as shown, and with the geothermal reservoir (49) forming part of the foundation of

20 the wind turbine (2). Section A-A of Figure 10 provides a cross-sectional view of the base (12), depicting refrigerant piping of the refrigerant circuit (51) associated with the compressed air tank (53), and an access shaft (66) provided in the base/tower (12).

During periods of low demand, the embodiment depicted in Figure 10 enters a “cooling cycle” in which a calculated amount of electrical power produced by the rotor of the wind turbine is used

25 to operate the high pressure air compressor to compress air from the environment into the compressed air storage tank. Compressing the air generates heat, which would otherwise reduce the amount of energy that can be stored. Accordingly, cold water from the geothermal reservoir is used to cool the compressed air (indirectly) during this mode of operation, allowing for more energy to be stored. In the process of cooling the compressed air, the refrigerant in refrigerant

circuit (51) draws heat from the compressed air and transfers the heat to the water in the refrigerant circuit (50) which is returned to the geothermal reservoir (49), causing heating of the reservoir water.

During periods of high demand, the embodiment depicted in Figure 10 enters a “heating cycle”,
5 in which a pneumatic drive uses the compressed air in the compressed air tank to add to the power generated by the rotor/blades of the wind turbine by using the pneumatic drive to add additional power to the flywheel and/or rotor blades. Hot water from the geothermal reservoir (49) is used to heat the refrigerant in the refrigerant circuit (51), which in turn heats air in the compressed air tank, increasing the amount of energy stored therein which may be supplied to
10 the rotors/blades for additional power production. In the process of heating the air, the refrigerant in the refrigerant circuit (51) is cooled, which cools the water of refrigerant circuit (50) which is returned to the reservoir, thus cooling the water in the geothermal reservoir (49), to be used in a subsequent cooling cycle as the generally self-sustained loop is repeated.

In the depicted wind turbine in Figure 10, a flywheel (60) is included as part of the drive train
15 which powers the generator. The flywheel is large, and takes significant energy to spin up from a stop. In certain embodiments, it is contemplated that compressed air and/or compressors of the wind turbine may be operated to maintain momentum of the flywheel and keep the generator running during low wind conditions, thereby reducing losses associated with repeated start/stop cycles. Likewise, in certain embodiments, it may be desirable to use the compressor(s) to keep
20 the momentum of the flywheel and the generator running at an efficient and substantially constant RPM, which may account for intermittent and variable wind conditions and/or provide improved efficiency.

Figure 11A depicts additional embodiments of compressed air-based energy storage units as described herein, which may be retrofitted to existing wind turbines (including traditional wind
25 turbines, for example), or included in new-build wind turbines. In the depicted embodiments, the compressed air-based energy storage unit is provided separately from the wind turbine with which it is in communication. The depicted compressed air-based energy storage units may be used in connection with one, or more than one, wind turbine (i.e. with multiple turbines). Markers (x), (y), and (z) denote different configurations of the depicted compressed air-based

energy storage unit. In configuration (x), the system includes compressor (54) and, optionally, compressor (55), as well as compressed air tank (53). In configuration (y), the system of (x) further includes a heat exchanger (52) and refrigerant circuit (51), the heat exchanger (52) using air as the source for heating and cooling of the compressed air tank. In configuration (z), the system of (y) further includes a geothermal reservoir (49) and refrigerant circuit (50) which circulates between the geothermal reservoir (49) and the heat exchanger (52), the heat exchanger (52) configured for thermal energy exchange between the refrigerant circuits (50) and (51).

Figure 11B depicts a conventional wind turbine which is fitted with an embodiment of a compressed air-based storage unit similar to that shown in configuration (z) of Figure 11A, but wherein the geothermal reservoir (49) is used as the foundation for the conventional wind turbine thus replacing the conventional foundation, which is typically one of the more expensive components of conventional wind turbines.

Methods for Generating Electricity

In another embodiment, there are provided herein methods for generating electricity using, for example, blades and/or wind turbines as described herein.

In certain embodiments, there is provided herein a method for generating electricity, said method comprising:

capturing wind energy by directing wind across a blade as described herein thereby causing the blade to rotate; and

using the captured wind energy to power an energy generation assembly to generate electricity.

In certain embodiments, the blades being used may be configured as part of a wind turbine as described herein.

In further embodiment, the method may further comprise:

storing surplus captured wind energy by vertically lifting a weight during low energy

demand conditions or high wind conditions, and

recovering stored surplus captured wind energy by vertically lowering the weight during high energy demand conditions or during low wind conditions to power the energy generation assembly to generate electricity.

5 In yet another embodiment, there is provided herein a method for generating electricity, said method comprising:

capturing wind energy by directing wind across a blade of a wind turbine to cause rotation thereof; and

10 using the captured wind energy to power an energy generation assembly to generate electricity;

wherein the method further comprises:

storing surplus captured wind energy by vertically lifting a weight during low energy demand conditions or high wind conditions; and

15 recovering stored surplus captured wind energy by vertically lowering the weight during high energy demand conditions or during low wind conditions to power the energy generation assembly to generate electricity.

In certain embodiments, the wind turbine being used may a wind turbine as described herein.

20 In certain embodiments, the weight (27) may be formed from a dense material such as, for example, iron ingot and/or metal slabs. As will be understood, the weight (27) functions to store potential energy. As such, it is also contemplated herein that other suitable potential energy storage mechanisms may be used including, by way of example, a spring or elastic potential energy storage member.

25 As will be understood, blades, turbines, and methods for generating electricity are described herein. The present description has been primarily described in the context of wind being used as the source of energy to be harnessed. It will be understood, however, that blades, turbines, and

methods as described herein may, in certain embodiments, be adapted to collect energy from other sources including, for example, another gas, liquid, or fluid. By way of example, it is contemplated that the presently described blades, turbines, and/or methods may be adapted to capture energy from flowing steam (i.e. may be adapted to function as a steam turbine). By way
5 of example, the presently described blades and turbines may, in certain embodiments, be adapted to harness energy from steam, geothermal, and/or solar sources. In certain embodiments, it is contemplated that blades and/or turbines described herein may be adapted for harnessing energy from compressed air; compressed air assisted with solar and/or geothermal energy; steam; and/or steam assisted with solar and/or geothermal energy. In certain embodiments, references herein to
10 “wind” may therefore be considered as encompassing a broad range of gas/liquid/fluid energy sources.

In yet another embodiment, there is provided herein a method for generating electricity, said method comprising:

15 capturing wind energy by directing wind across a blade of a wind turbine to cause rotation thereof; and

using the captured wind energy to power an energy generation assembly to generate electricity;

wherein the method further comprises:

20 storing surplus captured wind energy by powering an air compressor to generate a compressed air in a compressed air tank during low energy demand conditions or high wind conditions; and

25 recovering stored surplus captured wind energy by releasing the compressed air using the pneumatic drive to add additional energy to the flywheel and/or rotor/blades to cause rotation thereof during high energy demand conditions or during low wind conditions to power the energy generation assembly to generate electricity.

In another embodiment of the above method, the method may further comprise:

cooling the compressed air during the step of storing, thereby increasing energy storage by removing heat generated by compression;

heating the compressed air during the step of recovering, thereby increasing the amount of energy received by the blade of the wind turbine;

5 or both.

In still a further embodiment of the above method, the step of cooling may comprise cooling the compressed air using, directly or indirectly, a heat exchange fluid from a tank or reservoir, such as a geothermal reservoir, thereby cooling the compressed air and heating the heat exchange fluid of the tank or reservoir during the step of storing.

10 In still a further embodiment, the step of heating may comprise heating the compressed air using, directly or indirectly, the heat exchange fluid from the tank or reservoir, thereby heating the compressed air and cooling the heat exchange fluid of the tank or reservoir during the step of recovering.

15 In yet another embodiment, the method may comprise repeating the steps of storing and recovering as conditions cycle between low energy demand conditions or high wind conditions and high energy demand conditions or during low wind conditions.

Energy Storage

In yet another embodiment, there is provided herein a method for storing surplus energy captured by a wind turbine, the method comprising:

20 storing the surplus energy by vertically lifting a weight during low energy demand conditions or high wind conditions, and

recovering the stored surplus energy by vertically lowering the weight during high energy demand conditions or during low wind conditions to power an energy generation assembly to generate electricity.

25 In yet another embodiment, there is provided herein a method for storing surplus energy captured

by a wind turbine, the method comprising:

storing the surplus energy by powering an air compressor to generate a compressed air in a compressed air tank during low energy demand conditions or high wind conditions; and

5 recovering the stored surplus energy by releasing the compressed air and using the pneumatic drive to add additional energy to the flywheel and/or rotor/blades to cause rotation thereof during high energy demand conditions or during low wind conditions to power an energy generation assembly to generate electricity.

In another embodiment, the air compressor may be powered, in part or in full, by energy generated by the wind turbine.

10 In another embodiment of the above method, the method may further comprise:

cooling the compressed air during the step of storing, thereby increasing energy storage by removing heat generated by compression;

heating the compressed air during the step of recovering, thereby increasing the amount of energy received by the blade or blades of the wind turbine;

15 or both.

In still a further embodiment of the above method, the step of cooling may comprise cooling the compressed air using, directly or indirectly, a heat exchange fluid from a tank or reservoir, such as a geothermal reservoir, thereby cooling the compressed air and heating the heat exchange fluid of the tank or reservoir during the step of storing.

20 In still a further embodiment, the step of heating may comprise heating the compressed air using, directly or indirectly, the heat exchange fluid from the tank or reservoir, thereby heating the compressed air and cooling the heat exchange fluid of the tank or reservoir during the step of recovering.

In yet another embodiment, the method may comprise repeating the steps of storing and
25 recovering as conditions cycle between low energy demand conditions or high wind conditions

and high energy demand conditions or during low wind conditions.

In another embodiment, there is provided herein a compressed air-based energy storage system, the system comprising:

a compressed air tank;

5 an air compressor configured to compress air from an air inlet into the compressed air tank; and

an outlet from the compressed air tank, the outlet configured to direct compressed air from the compressed air tank to an electricity generation apparatus for generating electricity from the compressed air.

10 In a further embodiment, the air compressor may be powered, at least in part, by the electricity generation apparatus. In still a further embodiment, the electricity generation apparatus may comprise a wind turbine.

In another embodiment, the compressed air-based energy storage system may further comprise a heat exchange system configured to cool the compressed air while compressed air is being stored
15 in the compressed air tank, configured to heat the compressed air while compressed air is being directed through the outlet to the electricity generation apparatus, or both.

In still another embodiment, the heat exchange system may comprise a tank or reservoir, such as a geothermal reservoir, for a heat exchange fluid, the tank or reservoir configured to circulate the heat exchange fluid such that the heat exchange fluid provides, directly or indirectly, cooling to
20 the compressed air while compressed air is being stored in the compressed air tank, and becomes heated; heating to the compressed air while compressed air is being directed through the outlet to the electricity generation apparatus, and becomes cooled; or both.

EXAMPLE 1 – WIND TURBINE

25 An example of a particular wind turbine configuration, including a number of optional additional

features, is depicted in Figure 7. The depicted wind turbine example comprises a wind turbine (2) having 3 blades (1). Additional wind turbine features and operation of this particular example are described herein below.

In the depicted example, the energy generation assembly (22) comprises a rotor/hub (33) to which blades (1) are attached. Rotation of the rotor/hub (33) causes rotation of a low speed shaft (35), which is in communication with a brake (36) which may be used to stop rotation for, for example, performing maintenance. A flywheel (29) is in communication with the low speed shaft (35), the flywheel functions to store energy during strong wind gusts, which are later released at a more constant rate. In other words, strong wind gusts create energy, and it is contemplated that the flywheel may be used to store and release such energy at a more constant rate. The energy generation assembly (22) further comprises a winch (28) and a weight (27) in communication therewith. During periods of low demand and/or high wind, the winch (28) may be used to lift the weight (27), storing potential energy. When power demand increases, or when wind speed is low, the weight may be lowered to release energy which may be used for power generation and/or generator start-up.

The flywheel (29), together with winch (28) and weight (27), may be used to start a start-up generator (40) at low wind speed conditions. For conventional wind turbines, start-up wind speed has high energy requirements. By using stored energy in the form of the lifted weight (27) to cause rotation of the flywheel (29), momentum may be built up and used to start a start-up generator (27), thereby generating energy during low wind conditions and/or facilitating turbine start-up.

The low speed shaft (35) may be connected with a gear box (37) used for converting the low speed shaft rotation (for example, about 20 rpm to about 400 rpm) to high speed rotation (for example, about 1:200 – 1:800 rpm) of a high speed shaft (38), falling within a suitable rpm range for powering a typical generator. The skilled person will recognize that gearing and rpm ranges may be adjusted to suit the particular generator and/or application being employed. In certain embodiments, a direct-drive system lacking a gear box may be used.

The high speed shaft (38) is in communication with the start-up generator (40) and cut-in

generator (41). Operation of the start-up generator (40) and cut-in generator (41) may be regulated by a relay switch (43). A controller (39) may be included, which comprises a computer-based system which may, for example, run diagnostic tests, start and stop the turbine, and/or make turbine adjustments in response to variation in wind speed. A remote operator may
5 run system checks and/or input new parameters via communication with the controller (39). An anemometer (42) may be included for measuring wind speed.

In the illustrated example, the nacelle (19) is able to rotate about the base (18) via a bushing/bearing mechanism (45), allowing the nacelle to act as a vane to maintain proper orientation with respect to incoming wind, which may abrogate the need for a conventional yaw
10 drive.

The base (18) further includes a supporting member (23) extending from the base (18) to the rear end (21) of the nacelle (19). The base (18) additionally includes auxiliary support members (24) extending from each side of the supporting member (23) to each side of the nacelle (19), the supporting member (23) and two auxiliary support members (24) forming a tripart vane which
15 supports the nacelle (19) and reduces wind turbulence (i.e. linear flow) from the tower and adds structural stability.

The depicted wind turbine additionally includes a plurality of front louvres (25) and a plurality of back louvres (26), which may be activated to allow wind to pass through the interior of the nacelle (19), cooling the energy generation assembly (22) as needed. The rear louvres (25) are
20 located in an area of low wind speed and thus high pressure. Opening rear louvres (25) will allow wind to enter the nacelle (19). Front louvres (25) are located in an area of high wind speed and thus low pressure. Wind exhausted from the nacelle (19) through the front louvres (25) may then be fed back into the blades for additional torque in addition to cooling of the energy generation assembly. Such cooling effect may reduce need for operation of conventional chiller apparatus.

25 In the embodiment depicted in Figure 7, the weight (27) of the wind turbine includes a platform (46) atop the weight, which may be used as a service elevator/hoist to access the nacelle (19). The weight (27) may be lowered into a subsurface foundation (31) (see Figure 8A), and the platform (46) accessed by a user. The weight (27) may then be raised toward the nacelle, where

it may be received in a docking bay (44) portion of the nacelle (19).

The depicted embodiment includes a set of stay cables (32), see Figures 8A and 8B, stabilizing the base (18) tower. The stay cables (32) may stabilize the turbine even in higher wind conditions, which may allow for more versatile operation, while reducing foundation structure
5 (48) costs as compared with more elaborate/costly foundation structures. In certain embodiments, helical piles (47) may be used to secure the stay cables (32) to the surface, although many other suitable anchoring systems may be used.

One or more illustrative embodiments have been described by way of example. It will be understood to persons skilled in the art that a number of variations and modifications can be
10 made without departing from the scope of the invention as defined in the claims.

WHAT IS CLAIMED IS:

1. A blade for a wind turbine, the blade comprising:

a main blade portion having a first end, a second end, a wind-facing surface, and a rear surface,

5 the wind-facing surface of the main blade portion being shaped in a concave arc tracing a portion of a substantially circular path of radius r , the substantially circular path decreasing in radius r moving from the first end to the second end along the main blade portion, and

the main blade being curved moving from the first end to the second end,

10 such that incoming wind is received in a first direction at a wind capturing zone located in the vicinity of the first end, is funnelled along the wind-facing surface toward the second end of the main blade portion along an increasingly narrow pathway defined by the wind-facing surface, and exits the blade in a second direction at an increased velocity;

15 a leading edge portion extending from an upper edge of the wind-facing surface of the main blade portion, the leading edge portion projecting outwardly with respect to the substantially circular path, thereby providing a leading surface which directs additional wind onto the wind-facing surface of the main blade in the vicinity of the wind capturing zone and provides lift; and

20 a trailing edge portion extending from a lower edge of the wind-facing surface of the main blade portion, the trailing edge portion projecting inwardly with respect to the substantially circular path thereby providing a lower barrier for preventing wind escape during progression from the wind capturing zone toward the second end.

25 2. The blade according to claim 1, wherein the leading edge portion projects outwardly with respect to the substantially circular path at a tangent angle θ which increases moving from the first end to the second end.

3. The blade according to claim 1 or 2, wherein the leading edge portion projects outwardly with respect to the substantially circular path with a pitch angle p , which increases moving from the first end to the second end along the main blade portion.

5

4. The blade according to claim 3, wherein the pitch angle p increases from about 15° at the first end to about 75° at the second end of the main blade portion.

5. The blade according to claim any one of claims 2-4, wherein the trailing edge portion projects inwardly with respect to the substantially circular path at substantially the same angle as the leading edge portion.

6. The blade according to any one of claims 1-5, wherein the leading surface of the leading edge portion is oriented with respect to the trailing edge portion so as to direct wind under the trailing edge toward the first end of the main blade portion, and over the trailing edge portion toward the second end of the main blade portion.

7. The blade according to any one of claims 1-6, wherein the radius r of the substantially circular path decreases from about $1.75x$ at the first end to about $0.875x$ at the second end of the main blade portion.

8. The blade according to any one of claims 1-7, wherein the wind-facing surface of the main blade portion is shaped in a concave arc having a rise on chord b which increases from about $1x$ at the first end to about $1.5x$ proximate the first end, and then decreases to about $0.75x$ at the second end along the main blade portion.

9. The blade according to any one of claims 1-8, wherein the trailing edge portion increases and then decreases in size moving from the first end to the second end of the main blade portion.

5 10. The blade according to any one of claims 1-9, wherein the second direction at which wind exits the blade is substantially perpendicular to the first direction.

11. The blade according to any one of claims 1-10, wherein the second direction at which wind exits the blade is substantially tangential to the rotation of the blade during use.

10

12. The blade according to any one of claims 1-11, wherein the main blade is twisted moving from the first end to the second end, such that the second direction at which wind exits the blade is substantially tangential to the rotation of the blade during use.

15 13. The blade according to claim 12, wherein the twisting of the main blade begins toward the second end of the main blade.

20 14. The blade according to any one of claims 1-13, wherein the portion of the substantially circular path traced by the wind-facing surface of the main blade portion is defined by a chord angle A , which decreases moving from the first end to the second end along the main blade portion.

15. The blade according to claim 14, wherein the chord angle A decreases from about 90° at

the first end to about 0° at the second end.

16. The blade according to any one of claims 1-15, further comprising a jib blade attached to, and spaced apart from, the rear surface of the main blade and extending between the first end and
5 the second end of the main blade, the jib blade substantially following the curve of the main blade and becoming increasingly narrow moving from the first end toward the second end of the main blade, the jib blade directing air along the rear surface of the main blade with relatively low pressure reducing drag and providing lift to aid with rotation of the blade during use.

10 17. The blade according to claim 16, wherein the jib blade is spaced apart from the rear surface of the main blade by a distance y , where y increases moving from the first end to the second end along the main blade portion.

15 18. The blade according to claim 17, wherein the leading edge, trailing edge, and jib blade have a pitch angle p which is substantially the same.

19. A wind turbine comprising:

a base;

20 a nacelle supported by the base, the nacelle comprising a wind-facing end and a rear end and housing an energy generation assembly; and

a plurality of blades attached to the rear end of the nacelle.

20. The wind turbine according to claim 19, wherein the plurality of blades are blades according to any one of claims 1-18.

21. The wind turbine according to claim 19 or 20, wherein the wind turbine has 3 blades.
22. The wind turbine according to any one of claims 19-21, wherein the wind-facing end of
5 the nacelle is aerodynamically-shaped.
23. The wind turbine according to claim 22, wherein the wind-facing end of the nacelle is substantially cone-shaped or rounded cone-shaped.
- 10 24. The wind turbine according to any one of claims 19-23, wherein the nacelle is rotatable about the base, such that the nacelle and blades act as a vane, maintaining the wind facing-end of the nacelle facing into the wind.
- 15 25. The wind turbine according to any one of claims 19-24, wherein the base thickness narrows in the vicinity of the nacelle to reduce wind turbulence.
26. The wind turbine according to any one of claims 19-25, wherein the plurality of blades are adjustably attached to the rear end of the nacelle such that back sweep of the blades can be adjusted to accommodate different wind conditions.
- 20 27. The wind turbine according to claim 26, wherein back sweep of the blades can be decreased when wind conditions are weak, thereby capturing more wind at the wind capturing zone to assist energy production.

28. The wind turbine according to claim 26 or 27, wherein the back sweep of the blades can be increased when wind conditions are strong, thereby capturing less wind at the wind capturing zone to prevent damage to the wind turbine.

5

29. The wind turbine according to any one of claims 19-28, wherein the wind turbine comprises a supporting member extending from the base to the rear end of the nacelle, and an auxiliary support member extending from each side of the supporting member to each side of the nacelle, the supporting member and two auxiliary support members forming a tripart vane which supports the nacelle and reduces wind turbulence.

10

30. The wind turbine according to any one of claims 19-29, wherein the nacelle comprises at least one front louvre and at least one back louvre, which may be activated to allow wind to pass through the interior of the nacelle, cooling the energy generation assembly.

15

31. The wind turbine according to any one of claims 19-30, wherein the wind turbine further comprises:

a weight in communication with the energy generation assembly;

wherein the energy generation assembly is configured to store surplus energy by vertically lifting the weight during low demand or high wind conditions, and

20

wherein the energy generation assembly is configured to recover stored surplus energy by vertically lowering the weight during high demand, or during low wind conditions, and/or to facilitate start-up of the energy generation assembly.

32. The wind turbine according to claim 21, wherein the energy generation assembly comprises a winch for lifting the weight, and a fly wheel which is rotated by lowering the weight so as to build momentum for overcoming resistance to start-up of the energy generation assembly during low wind conditions and/or to maintain a more constant power output.

5

33. The wind turbine according to claim 31 or 32, wherein the base comprises a vertical support member, and the weight is housed within and vertically translatable along a length of the vertical support member.

10 34. The wind turbine according to any one of claims 31-33, wherein the vertical support member comprises a subsurface foundation, and the weight is housed in the subsurface foundation when not being used to store energy.

15 35. The wind turbine according to any one of claims 31-34, wherein the weight may be used as a hoist or service elevator transport to the nacelle and/or blades.

36. The wind turbine according to any one of claims 19-35, wherein the base is supported by one or more stay cables.

20 37. The wind turbine according to any one of claims 19-36, wherein the wind turbine is for harnessing energy from wind, steam, compressed air, solar, or geothermal driven sources.

38. A method for generating electricity, said method comprising:

capturing wind energy by directing wind across a blade according to any one of claims 1-18 to cause rotation thereof; and

using the captured wind energy to power an energy generation assembly to generate electricity.

5

39. The method according to claim 38, wherein the blade is a blade of a wind turbine according to any one of claims 19-37.

40. The method according to claim 38 or 39, wherein the method further comprises:

10 storing surplus captured wind energy by vertically lifting a weight during low energy demand conditions or high wind conditions, and

recovering stored surplus captured wind energy by vertically lowering the weight during high energy demand conditions or during low wind conditions to power the energy generation assembly to generate electricity.

15

41. A method for generating electricity, said method comprising:

capturing wind energy by directing wind across a blade of a wind turbine to cause rotation thereof; and

20 using the captured wind energy to power an energy generation assembly to generate electricity;

wherein the method further comprises:

storing surplus captured wind energy by vertically lifting a weight during low energy demand conditions or high wind conditions; and

recovering stored surplus captured wind energy by vertically lowering the weight

during high energy demand conditions or during low wind conditions to power the energy generation assembly to generate electricity.

42. A method for generating electricity, said method comprising:

5 capturing wind energy by directing wind across a blade of a wind turbine to cause rotation thereof; and

using the captured wind energy to power an energy generation assembly to generate electricity;

wherein the method further comprises:

10 storing surplus captured wind energy by powering an air compressor to generate a compressed air in a compressed air tank during low energy demand conditions or high wind conditions; and

15 recovering stored surplus captured wind energy by releasing the compressed air to a pneumatic drive to add additional energy to a flywheel or a rotor or the blade of the wind turbine or a combination of any of these to cause rotation thereof during high energy demand conditions or during low wind conditions to power the energy generation assembly to generate electricity.

43. The method of claim 42, wherein the method further comprises:

20 cooling the compressed air during the step of storing, thereby increasing energy storage by removing heat generated by compression;

heating the compressed air during the step of recovering, thereby increasing the amount of energy received by the blade of the wind turbine;

or both.

25

44. The method of claim 43, wherein the step of cooling comprises cooling the compressed air using, directly or indirectly, a heat exchange fluid from a tank or reservoir, thereby cooling the compressed air and heating the heat exchange fluid of the tank or reservoir during the step of storing.

5

45. The method of claim 43, wherein the step of heating comprises heating the compressed air using, directly or indirectly, a heat exchange fluid from a tank or reservoir, thereby heating the compressed air and cooling the heat exchange fluid of the tank or reservoir during the step of recovering.

10

46. The method of claim 44, wherein the step of heating comprises heating the compressed air using, directly or indirectly, the heat exchange fluid from the tank or reservoir, thereby heating the compressed air and cooling the heat exchange fluid of the tank or reservoir during the step of recovering.

15

47. The method of any one of claims 44-46, wherein the tank or reservoir is a geothermal reservoir.

48. The method of any one of claims 42-47, wherein the method comprises repeating the steps of storing and recovering as conditions cycle between low energy demand conditions or high wind conditions and high energy demand conditions or during low wind conditions.

20

49. A method for storing surplus energy captured by a wind turbine, the method comprising:
storing the surplus energy by vertically lifting a weight during low energy demand

conditions or high wind conditions, and

recovering the stored surplus energy by vertically lowering the weight during high energy demand conditions or during low wind conditions to power an energy generation assembly to generate electricity.

5

50. A method for storing surplus energy captured by a wind turbine, the method comprising:
storing the surplus energy by powering an air compressor to generate a compressed air in a compressed air tank during low energy demand conditions or high wind conditions; and
recovering the stored surplus energy by releasing the compressed air to a pneumatic drive
10 to add additional energy to a flywheel or a rotor or a blade or blades of the wind turbine or a combination of any of these to cause rotation thereof during high energy demand conditions or during low wind conditions to power an energy generation assembly to generate electricity.

15 51. The method of claim 50, wherein the air compressor is powered, in part or in full, by energy generated by the wind turbine.

52. The method of claim 50 or 51, further comprising:
cooling the compressed air during the step of storing, thereby increasing energy storage
20 by removing heat generated by compression;
heating the compressed air during the step of recovering, thereby increasing the amount of energy received by the blade or blades of the wind turbine;
or both.

53. The method of claim 52, wherein the step of cooling comprises cooling the compressed air using, directly or indirectly, a heat exchange fluid from a tank or reservoir, thereby cooling the compressed air and heating the heat exchange fluid of the tank or reservoir during the step of storing.

5

54. The method of claim 52, wherein the step of heating comprises heating the compressed air using, directly or indirectly, a heat exchange fluid from a tank or reservoir, thereby heating the compressed air and cooling the heat exchange fluid of the tank or reservoir during the step of recovering.

10

55. The method of claim 53, wherein the step of heating comprises heating the compressed air using, directly or indirectly, the heat exchange fluid from the tank or reservoir, thereby heating the compressed air and cooling the heat exchange fluid of the tank or reservoir during the step of recovering.

15

56. The method of any one of claims 53-55, wherein the tank or reservoir is a geothermal reservoir.

20

57. The method of any one of claims 50-56, wherein the method comprises repeating the steps of storing and recovering as conditions cycle between low energy demand conditions or high wind conditions and high energy demand conditions or during low wind conditions.

58. A compressed air-based energy storage system, the system comprising:
a compressed air tank;

an air compressor configured to compress air from an air inlet into the compressed air tank; and

an outlet from the compressed air tank, the outlet configured to direct compressed air from the compressed air tank to an electricity generation apparatus for generating
5 electricity from the compressed air.

59. The compressed air-based energy storage system of claim 58, wherein the air compressor is powered, at least in part, by the electricity generation apparatus.

10 60. The compressed air-based energy storage system of claim 58 or 59, wherein the electricity generation apparatus comprises a wind turbine.

15 61. The compressed air-based energy storage system of any one of claims 58-60, wherein the system further comprises a heat exchange system configured to cool the compressed air while compressed air is being stored in the compressed air tank, configured to heat the compressed air while compressed air is being directed through the outlet to the electricity generation apparatus, or both.

20 62. The compressed air-based energy storage system of claim 61, wherein the heat exchange system comprises a tank or reservoir for a heat exchange fluid, the tank or reservoir configured to circulate the heat exchange fluid such that the heat exchange fluid provides, directly or indirectly, cooling to the compressed air while compressed air is being stored in the compressed air tank, and becomes heated; heating to the compressed air while compressed air is being directed through the outlet to the electricity generation apparatus, and becomes cooled; or both.

25

63. The compressed air-based energy storage system of claim 62, wherein the tank or reservoir comprises a geothermal reservoir.

64. A wind turbine comprising:

- 5 a base;
- a nacelle supported by the base;
- a plurality of blades attached to the nacelle; and
- a compressed air-based energy storage system as defined in any one of claims 58-63.

10

65. The wind turbine of claim 64, wherein the blades are blades as defined in any one of claims 1-18.

15

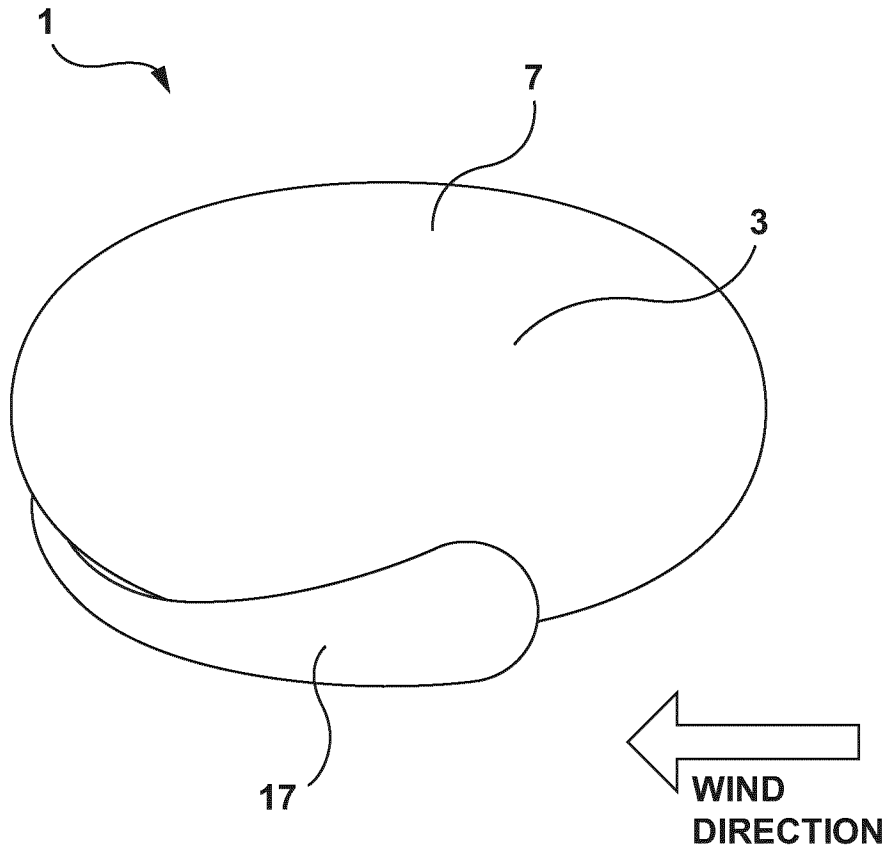

FIG. 1

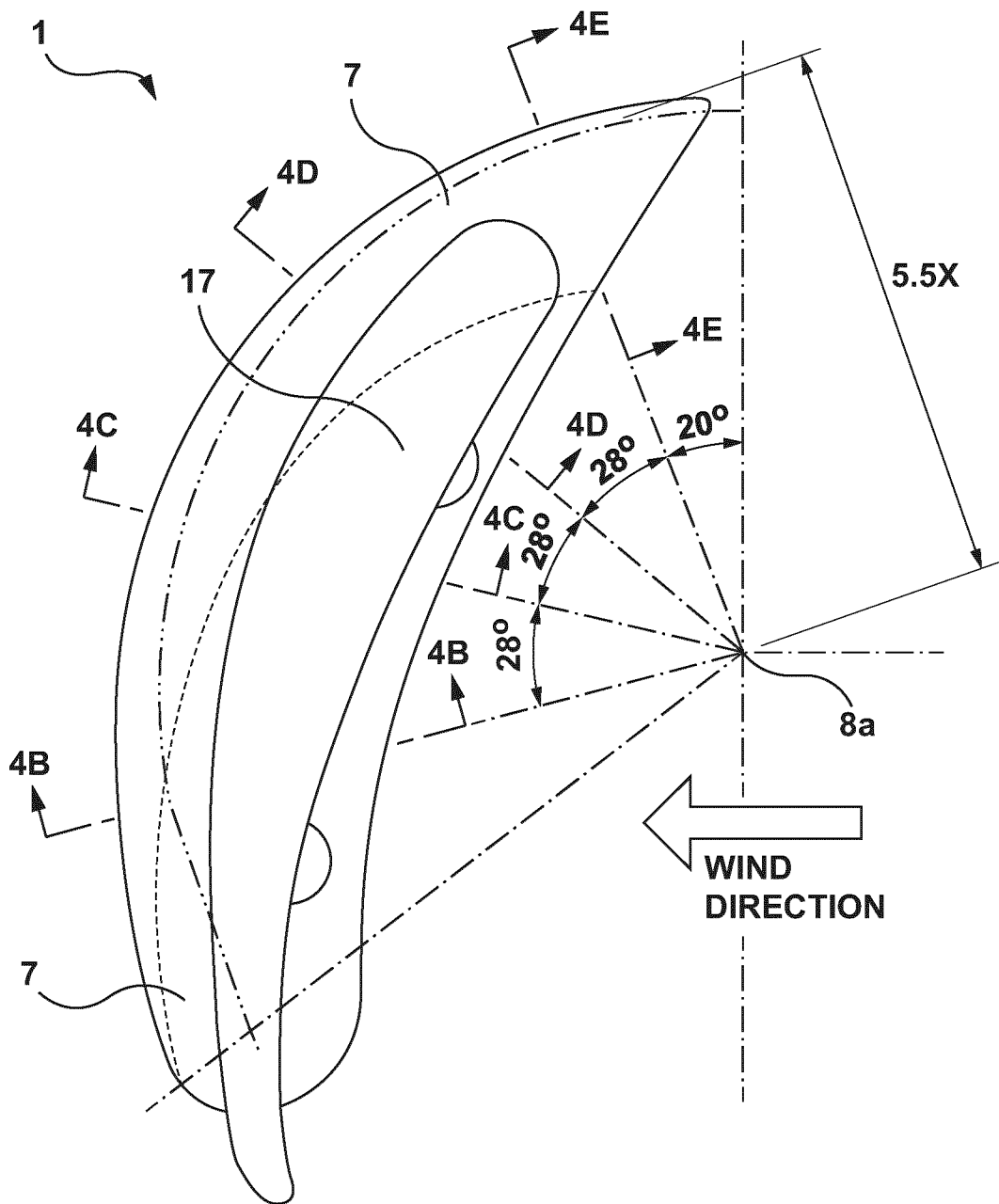

FIG. 2

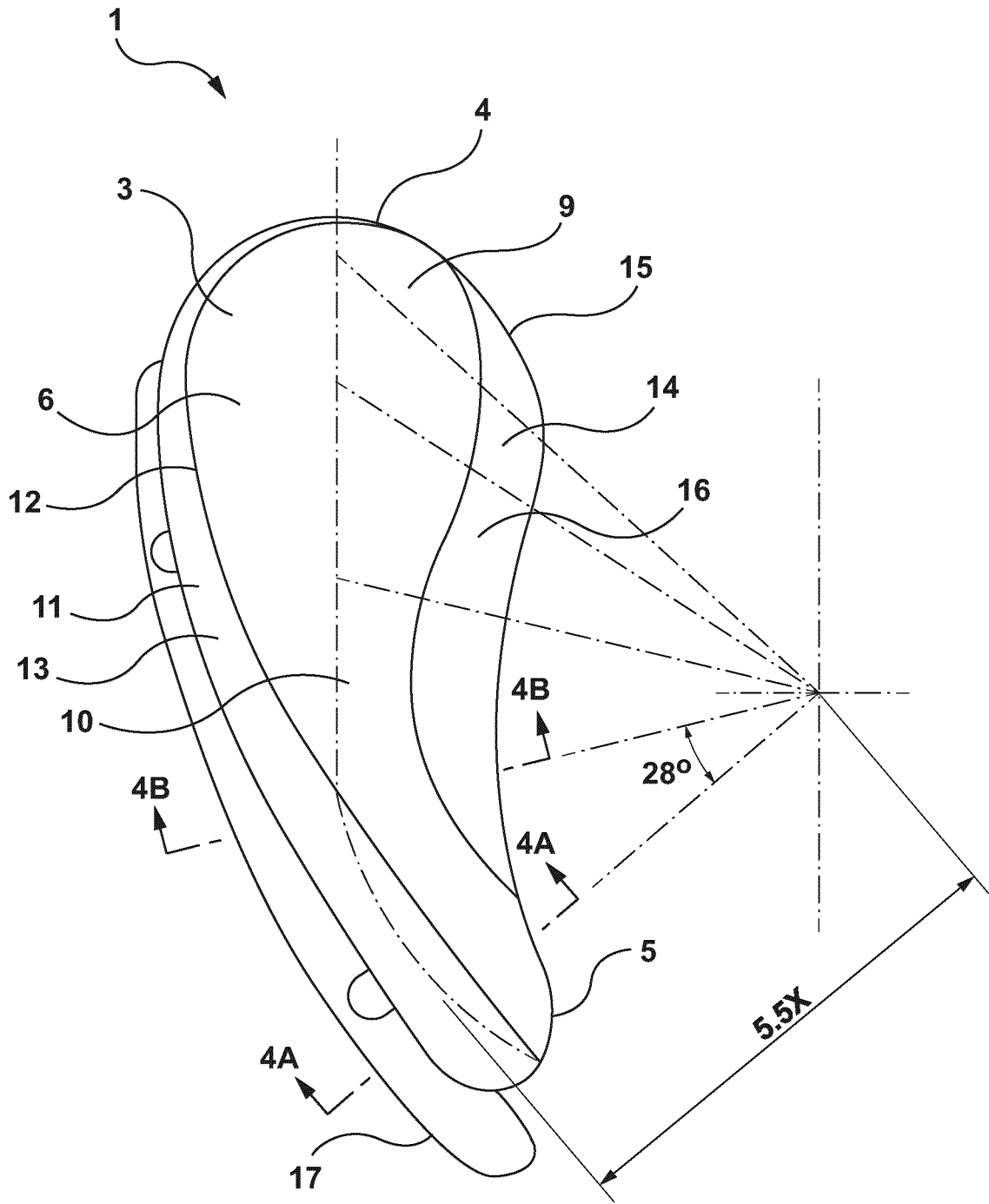

FIG. 3

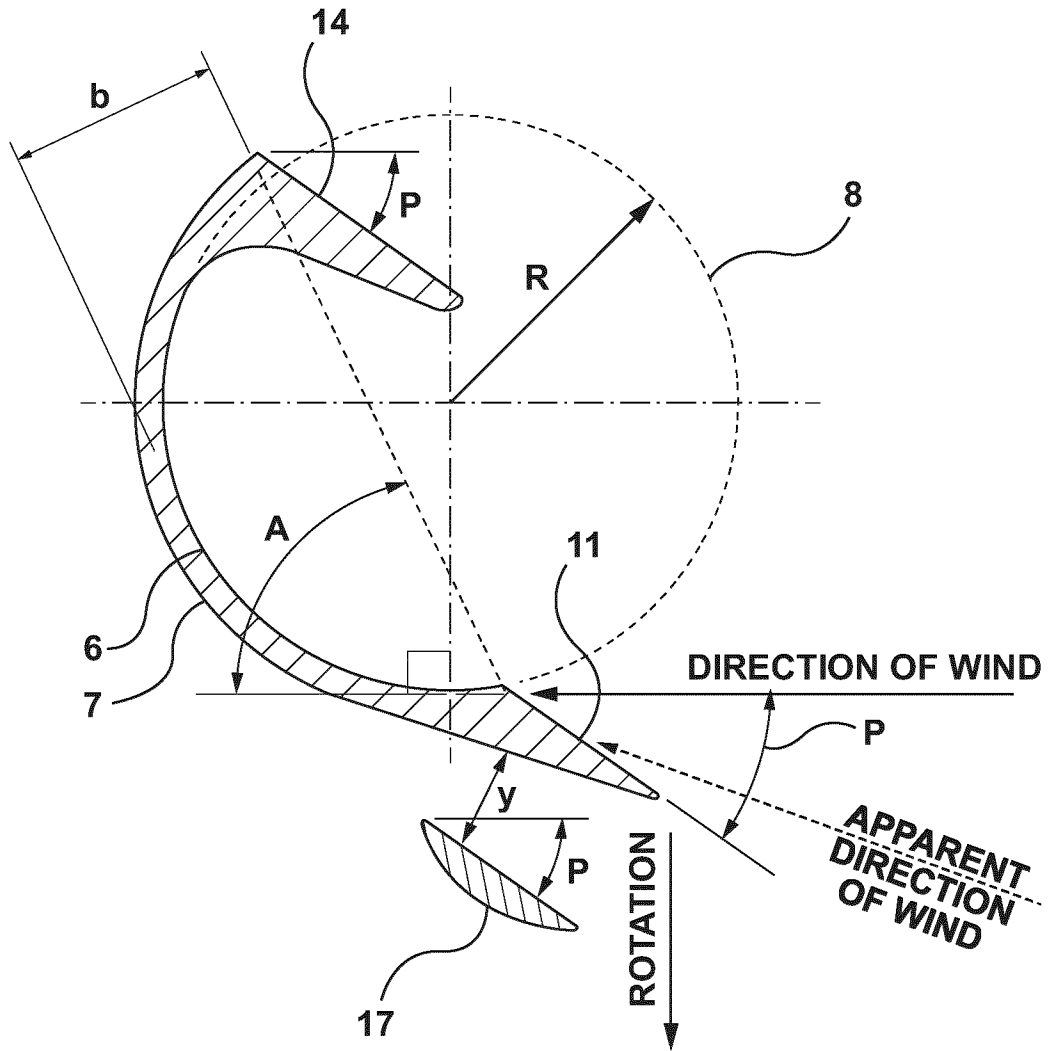

FIG. 4

5 / 12

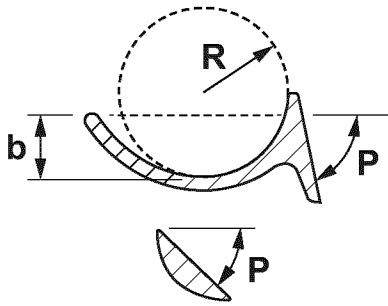

FIG. 5A

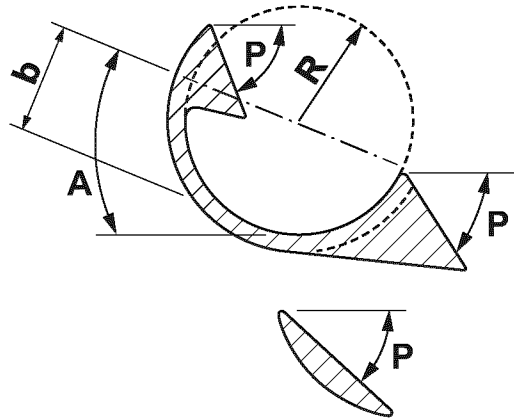

FIG. 5B

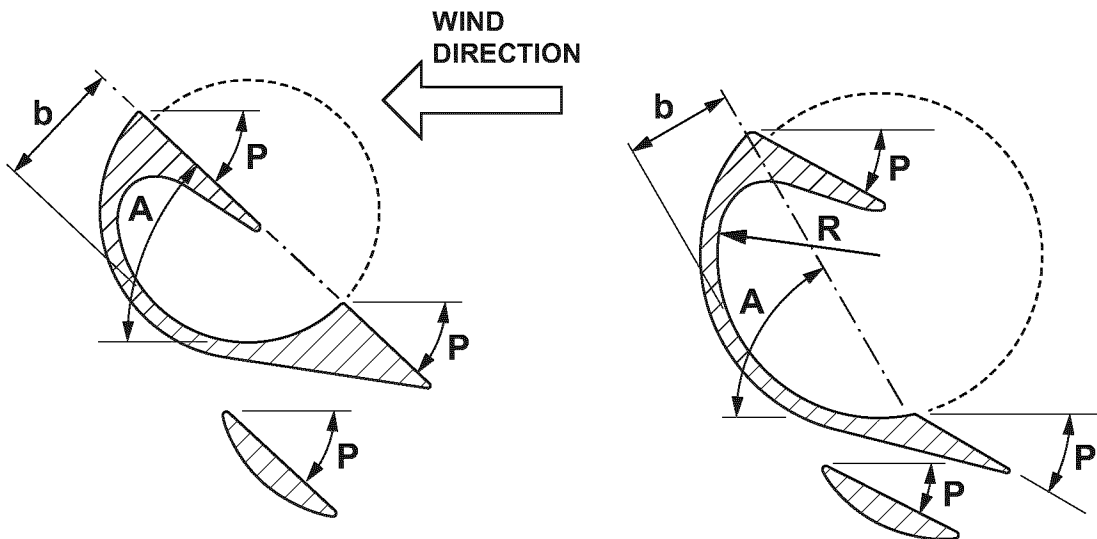

FIG. 5C

FIG. 5D

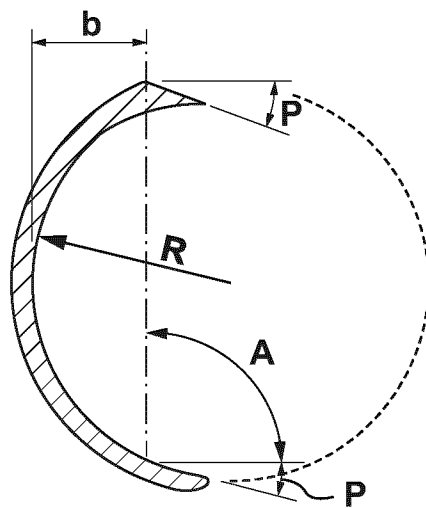

FIG. 5E

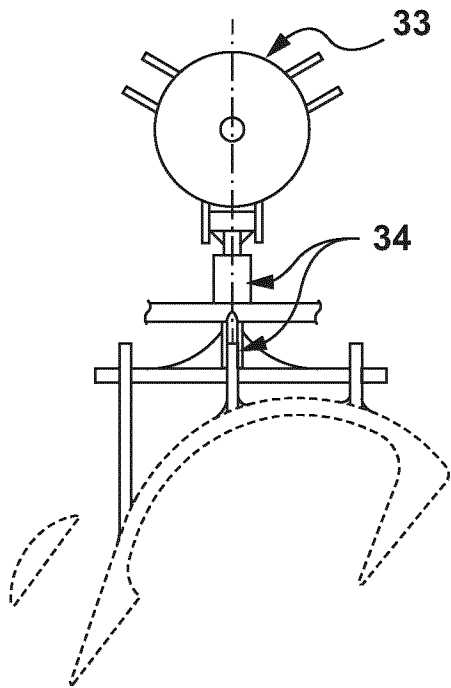

FIG. 6A

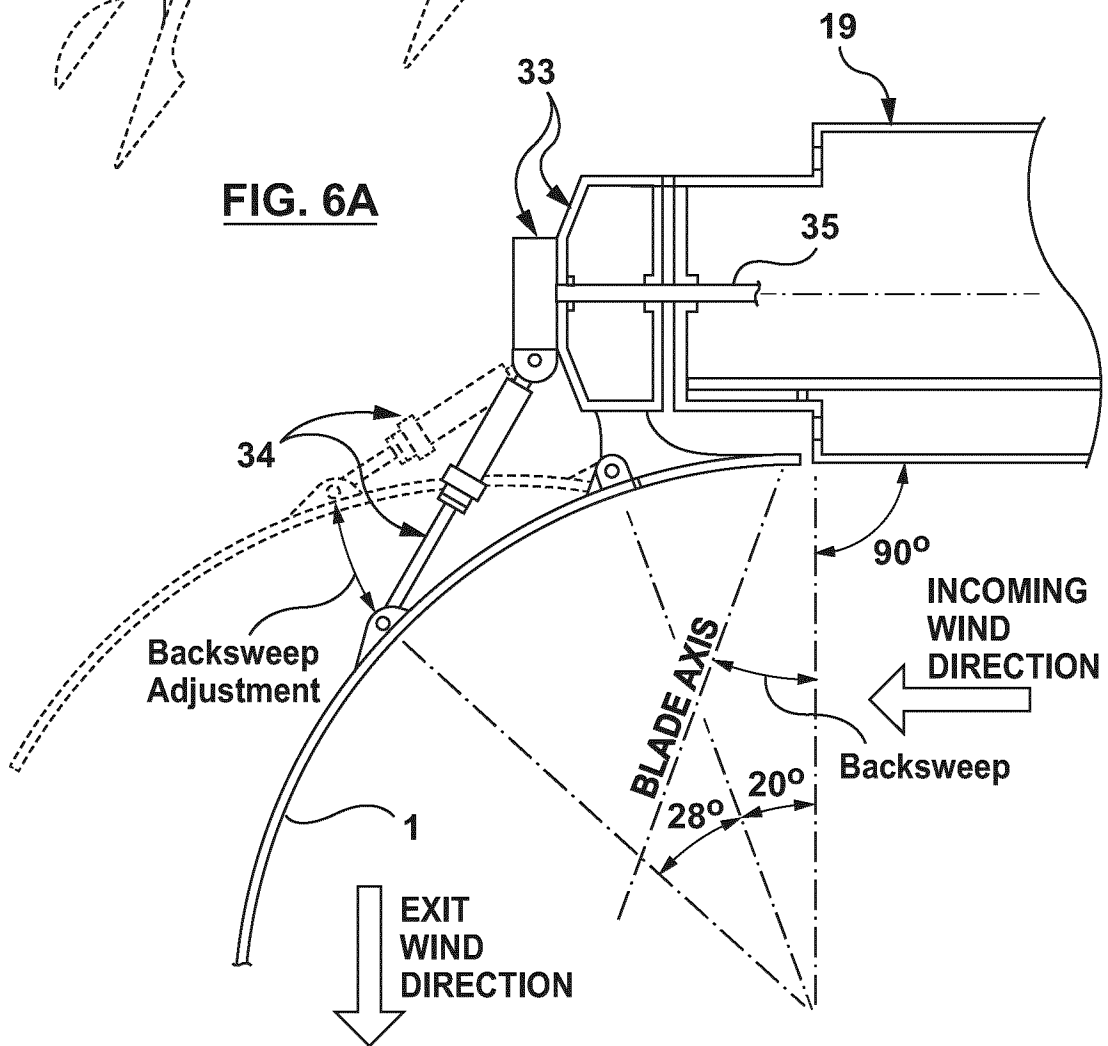

FIG. 6B

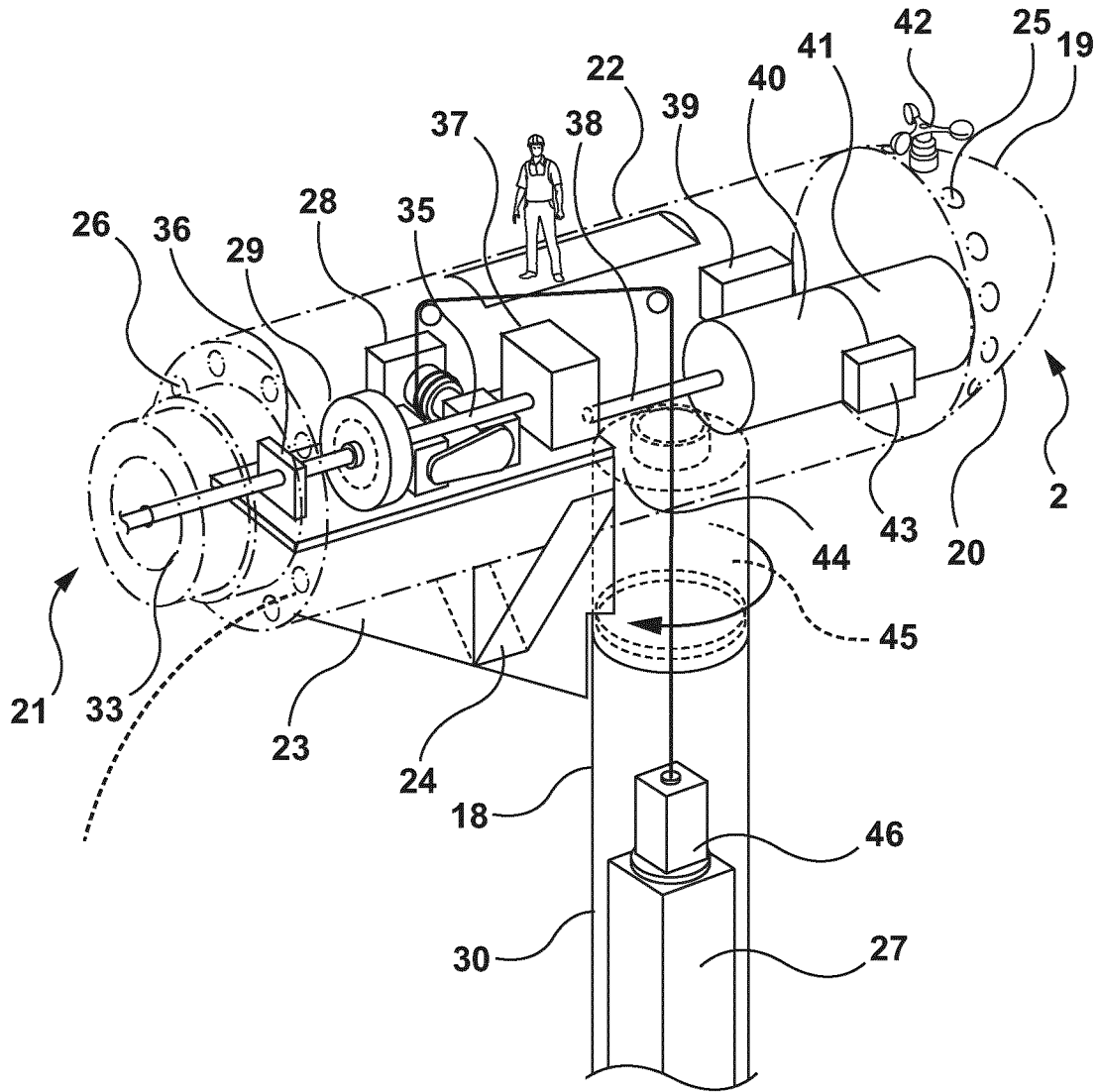

FIG. 7

8 / 12

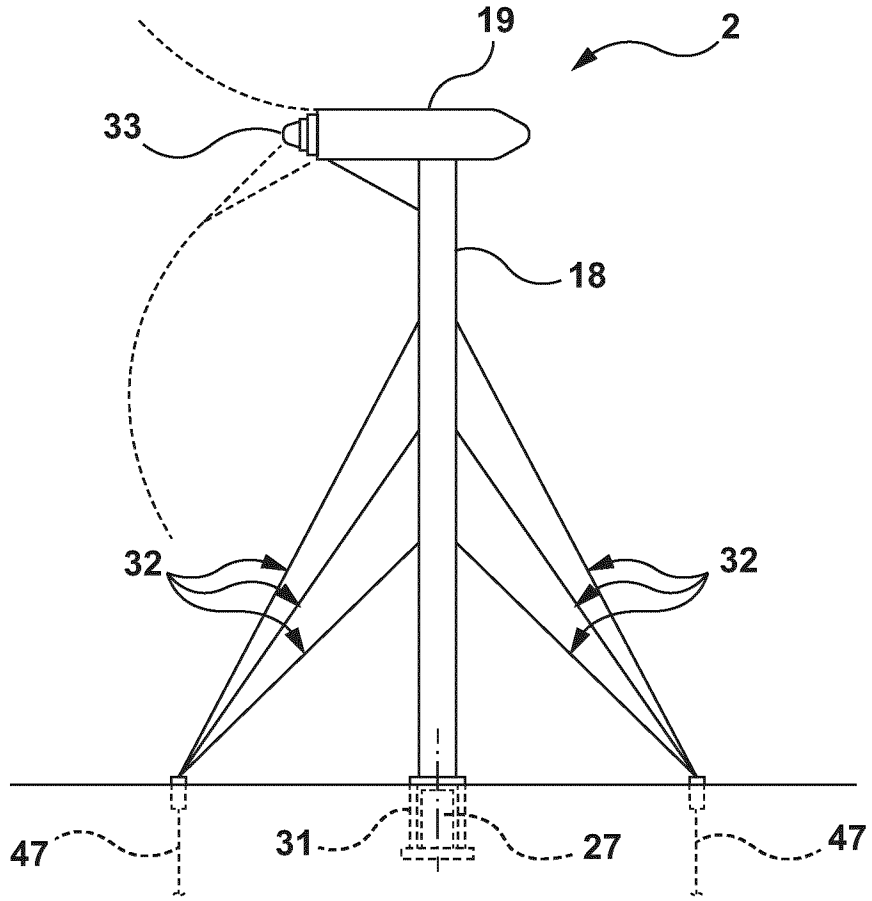

FIG. 8A

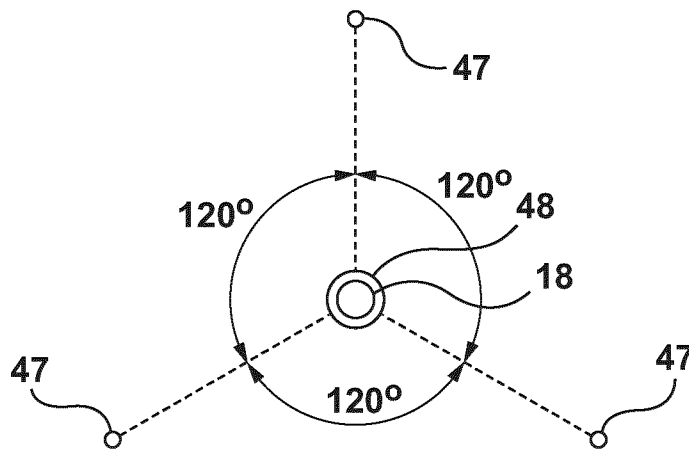

FIG. 8B

9 / 12

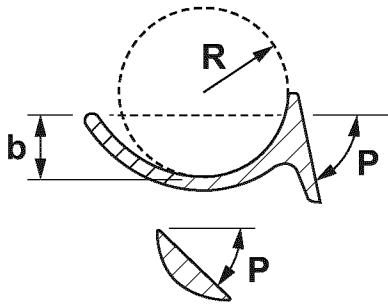

FIG. 9A

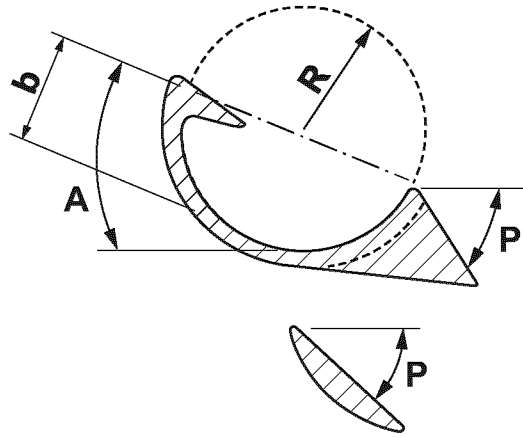

FIG. 9B

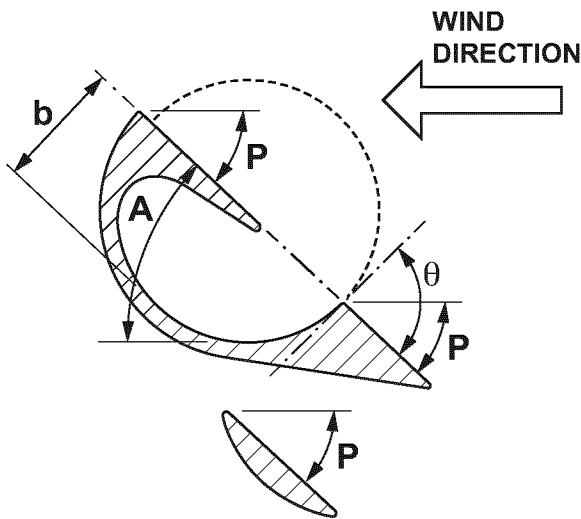

FIG. 9C

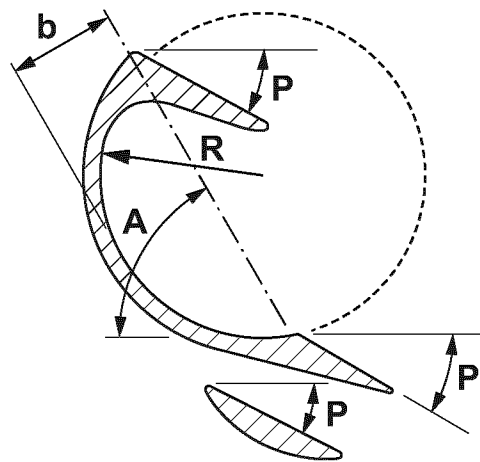

FIG. 9D

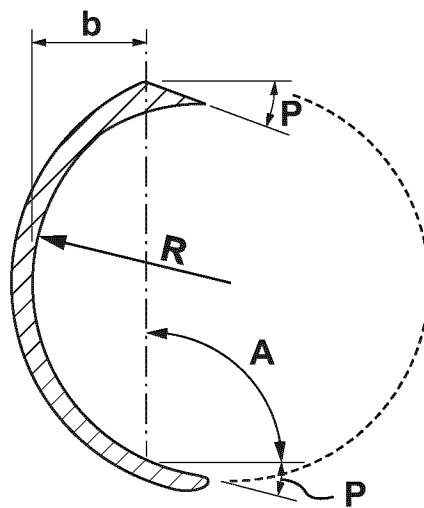

FIG. 9E

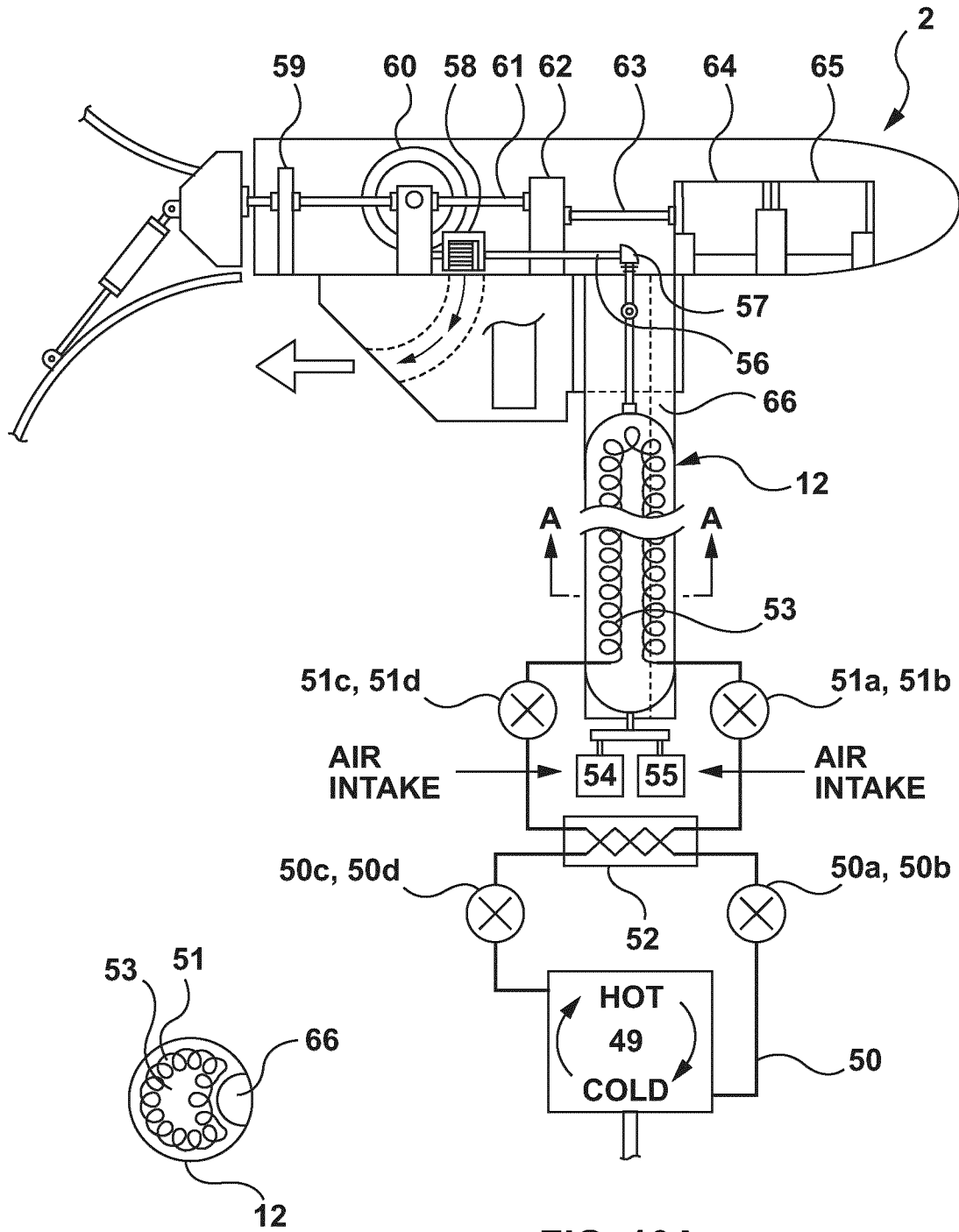

FIG. 10B

FIG. 10A

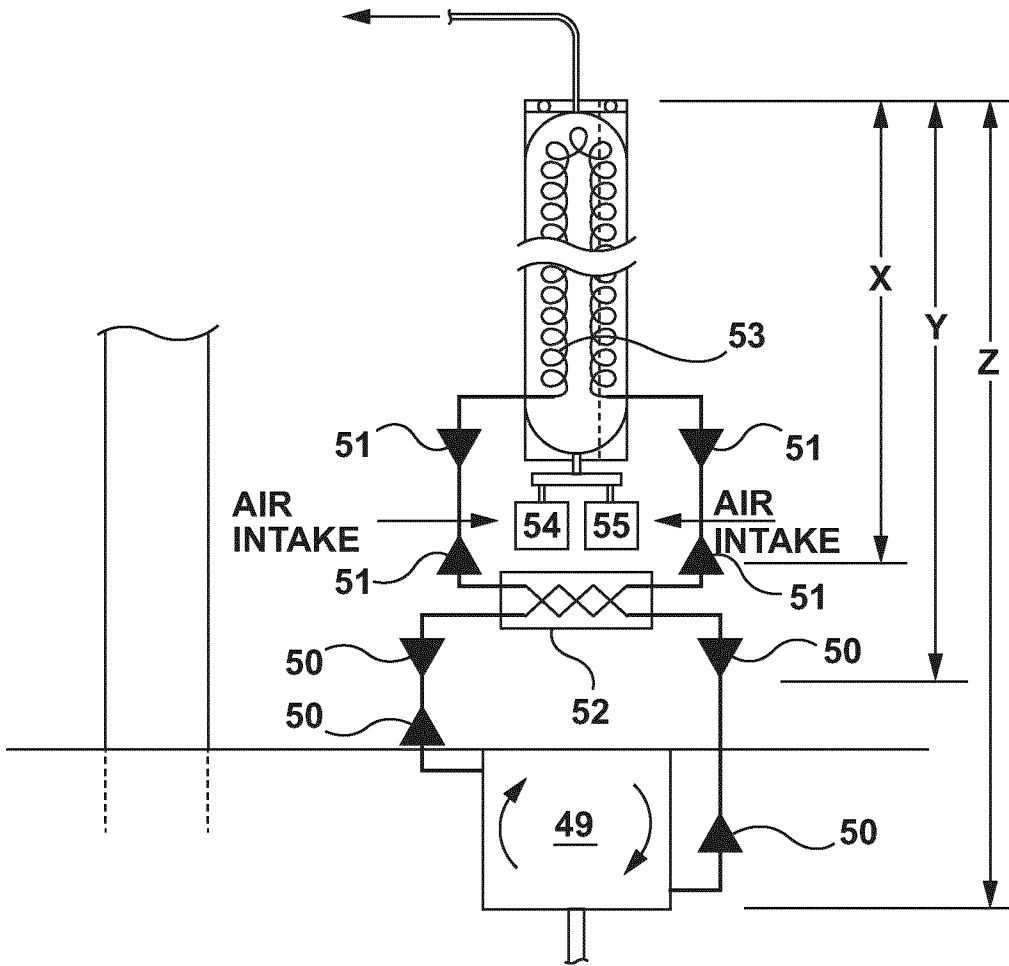

FIG. 11A

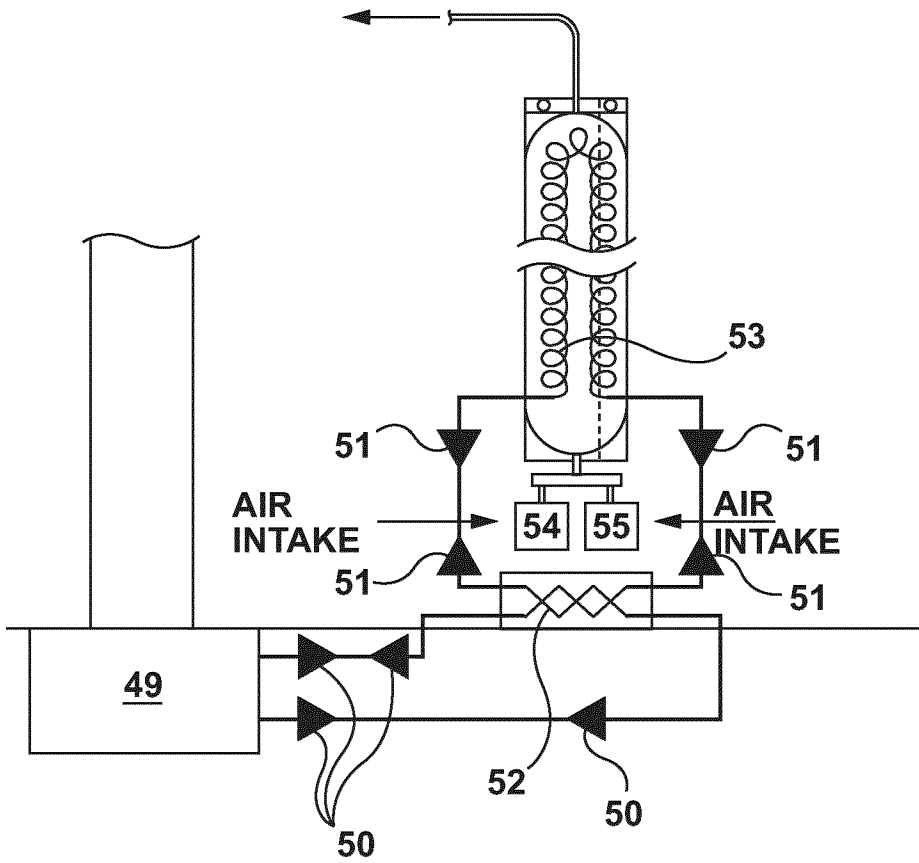

FIG. 11B

INTERNATIONAL SEARCH REPORT

International application No.

PCT/CA2018/050897

A. CLASSIFICATION OF SUBJECT MATTER
 IPC: **F03D 1/06** (2006.01), **F03D 9/16** (2016.01), *F03D 9/25* (2016.01), *F03D 9/14* (2016.01)

According to International Patent Classification (IPC) or to both national classification and IPC

B. FIELDS SEARCHED

Minimum documentation searched (classification system followed by classification symbols)
 IPC: F03D 1/06 (2006.01), F03D 9/16 (2016.01), F03D 9/25 (2016.01), F03D 9/14 (2016.01)

Documentation searched other than minimum documentation to the extent that such documents are included in the fields searched

Electronic database(s) consulted during the international search (name of database(s) and, where practicable, search terms used)
 Databases: Canadian Patent Database, Questel/Orbit, Google Patents

Keywords: wind, turbine, arc, concave, extend*, edge, project*, diver*, channel, recess, passage, twist*, curv*, deflect*

C. DOCUMENTS CONSIDERED TO BE RELEVANT

Category*	Citation of document, with indication, where appropriate, of the relevant passages	Relevant to claim No.
X	US 8747067 B2 (BARBAN, R.) 10 June 2014 (10-06-2014) *Abstract; Col. 2, lines 7-30; Col. 4, lines 7-33; Col. 5, lines 32-50 and Col. 6, lines 9-15; Fig. 1, 3, 6, 7, 8*	1-18, 38
A	CA 2719144 C (HADDJERI, N.) 5 November 2009 (05-11-2009) *Abstract; p. 1, lines 25-32; Fig. 1-8*	1-18, 38
A	WO 2005/015009 A1 (HANEDA MASAJI) 17 February 2005 (17-02-2005) *Fig. 1-7*	1-18, 38
A	CA 1266005 A (OBIDNIAK, L.) 20 February 1990 (20-02-1990) *Fig. 1-3*	1-18, 38
A	US 5656865 A (FRANKLIN, E.) 12 August 1997 (12-08-1997) *Abstract; Fig. 1-3, 5*	1-18, 38

Further documents are listed in the continuation of Box C.

See patent family annex.

* "A" "E" "L" "O" "P"	Special categories of cited documents: document defining the general state of the art which is not considered to be of particular relevance earlier application or patent but published on or after the international filing date document which may throw doubts on priority claim(s) or which is cited to establish the publication date of another citation or other special reason (as specified) document referring to an oral disclosure, use, exhibition or other means document published prior to the international filing date but later than the priority date claimed	"T" "X" "Y" "&"	later document published after the international filing date or priority date and not in conflict with the application but cited to understand the principle or theory underlying the invention document of particular relevance; the claimed invention cannot be considered novel or cannot be considered to involve an inventive step when the document is taken alone document of particular relevance; the claimed invention cannot be considered to involve an inventive step when the document is combined with one or more other such documents, such combination being obvious to a person skilled in the art document member of the same patent family
--------------------------------------	--	--------------------------	--

Date of the actual completion of the international search
 15 August 2018 (15-08-2018)

Date of mailing of the international search report
 23 October 2018 (23-10-2018)

Name and mailing address of the ISA/CA
 Canadian Intellectual Property Office
 Place du Portage I, C114 - 1st Floor, Box PCT
 50 Victoria Street
 Gatineau, Quebec K1A 0C9
 Facsimile No.: 819-953-2476

Authorized officer
 Gilbert Plouffe (819) 639-7885

INTERNATIONAL SEARCH REPORT

International application No.

PCT/CA2018/050897

C (Continuation). DOCUMENTS CONSIDERED TO BE RELEVANT

Category*	Citation of document, with indication, where appropriate, of the relevant passages	Relevant to claim No.
A	US 2021707 A (UPSON, W.) 19 November 1935 (19-11-1935) *Whole document*	1-18, 38
A	US 4632636 A (SMITH, W.) 30 December 1986 (30-12-1986) *Whole document*	1-18, 38

Box No. II Observations where certain claims were found unsearchable (Continuation of item 2 of the first sheet)

This international search report has not been established in respect of certain claims under Article 17(2)(a) for the following reasons:

1. Claim Nos.:
because they relate to subject matter not required to be searched by this Authority, namely:

2. Claim Nos.:
because they relate to parts of the international application that do not comply with the prescribed requirements to such an extent that no meaningful international search can be carried out, specifically:

3. Claim Nos.:
because they are dependent claims and are not drafted in accordance with the second and third sentences of Rule 6.4(a).

Box No. III Observations where unity of invention is lacking (Continuation of item 3 of first sheet)

This International Searching Authority found multiple inventions in this international application, as follows:

See extra sheet

1. As all required additional search fees were timely paid by the applicant, this international search report covers all searchable claims.
2. As all searchable claims could be searched without effort justifying additional fees, this Authority did not invite payment of additional fees.
3. As only some of the required additional search fees were timely paid by the applicant, this international search report covers only those claims for which fees were paid, specifically claim Nos.:

4. No required additional search fees were timely paid by the applicant. Consequently, this international search report is restricted to the invention first mentioned in the claims; it is covered by claim Nos.:

1-18 and 38

- Remark on Protest**
- The additional search fees were accompanied by the applicant's protest and, where applicable, the payment of a protest fee.
 - The additional search fees were accompanied by the applicant's protest but the applicable protest fee was not paid within the time limit specified in the invitation.
 - No protest accompanied the payment of additional search fees.

Group A - Claims 1-18 and 38 are directed to a blade for a wind turbine having a wind-facing surface shaped in a concave arc; a leading edge portion extending from an upper edge of the wind-facing surface and a trailing edge portion extending from a lower edge of the wind-facing surface;

Group B - Claim 19 is directed to a wind turbine comprising a plurality of blades attached to the rear end of the nacelle;

Group C - Claims 41 and 49 are directed to a method for generating electricity comprising storing surplus captured wind energy by vertically lifting a weight during low energy demand conditions or high wind conditions; and recovering stored surplus captured wind energy by vertically lowering the weight during high energy demand conditions to power the energy generation assembly to generate electricity;

Group D - Claims 42-48, 50-57, 58-63 and 64 are directed to a method for generating electricity comprising storing surplus captured wind energy by powering an air compressor to generate a compressed air in a compressed air tank during low energy demand conditions or high wind conditions; and recovering stored surplus captured wind energy by releasing the compressed air to a pneumatic drive to add additional energy to a flywheel or a rotor or the blade of the wind turbine or a combination of any of these to cause rotation thereof during high energy demand conditions or during low wind conditions to power the energy generation assembly to generate electricity;

The subject matter of claims 20-37 may be combined with the subject matter of claims of Group A or B; the subject matter of claims 39-40 may be combined with the subject matter of claims of Group A or B, and the subject matter of claim 65 may be combined with the subject matter of claims of Group A or D.

There is no common inventive concept linking the independent claims together.

The claims must be limited to one inventive concept as set out in **PCT Rule 13**.

INTERNATIONAL SEARCH REPORT
Information on patent family members

International application No.
PCT/CA2018/050897

Patent Document Cited in Search Report	Publication Date	Patent Family Member(s)	Publication Date
US8747067B2	10 June 2014 (10-06-2014)	US2014105740A1 US8747067B2 US2015104312A1 US9464621B2	17 April 2014 (17-04-2014) 10 June 2014 (10-06-2014) 16 April 2015 (16-04-2015) 11 October 2016 (11-10-2016)
CA2719144A1	05 November 2009 (05-11-2009)	CA2719144A1 CA2719144C AU2009241880A1 BRPI0911220A2 CN102016295A CN102016295B EP2294313A2 EP2294313B1 ES2397808T3 FR2930300A1 FR2930300B1 HK1156674A1 JP2011518287A JP5701204B2 MX2010011600A NZ588867A RU2010147354A RU2557966C2 US2011070094A1 US8562299B2 WO2009133318A2 WO2009133318A3	05 November 2009 (05-11-2009) 21 June 2016 (21-06-2016) 05 November 2009 (05-11-2009) 29 September 2015 (29-09-2015) 13 April 2011 (13-04-2011) 31 July 2013 (31-07-2013) 16 March 2011 (16-03-2011) 05 September 2012 (05-09-2012) 11 March 2013 (11-03-2013) 23 October 2009 (23-10-2009) 21 October 2011 (21-10-2011) 25 April 2014 (25-04-2014) 23 June 2011 (23-06-2011) 15 April 2015 (15-04-2015) 11 April 2011 (11-04-2011) 26 April 2013 (26-04-2013) 27 May 2012 (27-05-2012) 27 July 2015 (27-07-2015) 24 March 2011 (24-03-2011) 22 October 2013 (22-10-2013) 05 November 2009 (05-11-2009) 07 January 2010 (07-01-2010)
WO2005015009A1	17 February 2005 (17-02-2005)	WO2005015009A1 JP2005061233A	17 February 2005 (17-02-2005) 10 March 2005 (10-03-2005)
CA1266005A	20 February 1990 (20-02-1990)	CA1266005A US4915580A	20 February 1990 (20-02-1990) 10 April 1990 (10-04-1990)
US5656865A	12 August 1997 (12-08-1997)	US5656865A AU7017696A WO9711272A1	12 August 1997 (12-08-1997) 09 April 1997 (09-04-1997) 27 March 1997 (27-03-1997)
US2021707A	19 November 1935 (19-11-1935)	None	
US4632636A	30 December 1986 (30-12-1986)	None	